

**BUTT JOINT DETAIL**

STA 140+47.14 TO STA 140+92.14  
 STA 614+30.00 TO STA 614+75.00  
 CANNABLE RD. (NORTH)  
 CANNABLE RD. (SOUTH)

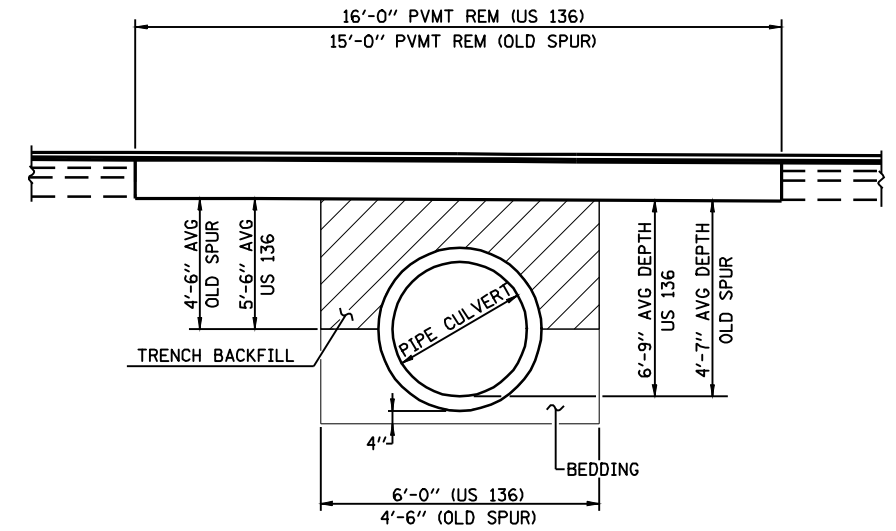

**TRENCH BACKFILL DETAIL**

• STA 430+41.42 (US 136)  
 PIPE CULV. CL. A, TY 1, 30"  
 • OLD SPUR EAST CONNECTOR  
 PIPE CULV. CL. A, TY 1, EQUIV. ROUND - SIZE 24"

**LEGEND**

- ① EX PCC PVMT (9"-6"-9")
- ② EX HMA SURF VAR 3"-4"
- ③ EX HMA BSE CSE WIDENING 9"
- ③a STABILIZED BSE CSE 9"
- ④ EX STABILIZED SHLD (BAM) 8"
- ⑤ EX HMA SHLD 10"
- ⑥ EX AGG BSE CSE 6"
- ⑦ EX AGG BSE CSE 8"
- ⑧ EX AGG SHLD
- ⑨ EX PCC TYPE A GUTTER
  
- ⑩ PR HMA SURF CSE 1 1/2"
- ⑪ PR HMA BINDER 3/4" & VAR (3/4" MIN)
- ⑫ PR HMA REM VAR DEPTH (3/4" @ CL)
- ⑬ PR HMA SURF REM 3/4" & VAR - 2 1/4"
- ⑭ PR HMA SHLD REM 8"
- ⑮ PR HMA SHLD 2 1/4"
- ⑯ PR HMA SHLD 10"
- ⑰ PR AGG SHLD, TYPE B
- ⑱ PR PVMT MARKING, LINE 5"

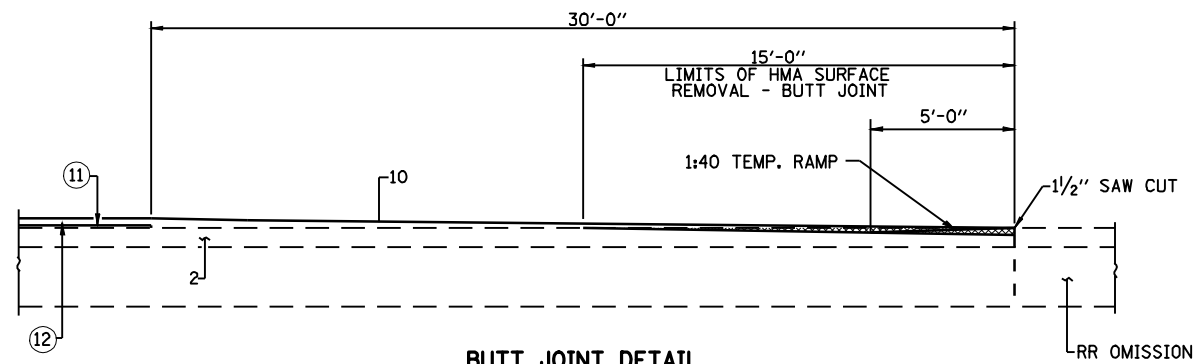

**BUTT JOINT DETAIL**

STA 318+07.51 TO STA 318+52.51  
 STA 318+75.17 TO STA 319+20.17

FILE NAME =	USER NAME = laughlinr1	DESIGNED -	REVISED -	<b>STATE OF ILLINOIS DEPARTMENT OF TRANSPORTATION</b>	<b>BUTT JOINT, TEMPORARY/RAMP AND TRENCH BACKFILL DETAILS</b>			F.A.P. RTE.	SECTION	COUNTY	TOTAL SHEETS	SHEET NO.
c:\pwwork\pwwid\LAUGHLINRL\0159574\0672063-sht-details.dgn	DRAWN -	REVISED -	315					(28, 29) (RS-5)	HANCOCK	40	35	
PLOT SCALE = 10.0000 ' / IN.	CHECKED -	REVISED -	CONTRACT NO. 72C63									
PLOT DATE = Apr-07-2010 08:39:45AM	DATE -	REVISED -	ILLINOIS FED. AID PROJECT									
					SCALE:	SHEET NO.	OF SHEETS	STA.	TO STA.			