

* - PAVED SHOULDER LIMITS:
294+17.4 TO 297+94.9 RT
294+48.2 TO 298+04.4 LT

TYPICAL FAP 751 (IL 106) SECTION

STA 294+17.00 TO STA 295+75.36
STA 295+75.36 TO STA 296+64.45 SN 075-0024 OMISSION
STA 296+64.45 TO STA 298+15.00

LEGEND

- (E1) EXISTING HOT-MIX ASPHALT SURFACE AND BINDER, VARIABLE DEPTH
- (E2) EXISTING PCC BASE COURSE, 9"
- (E3) EXISTING HOT-MIX ASPHALT SHOULDER, 9"
- (E4) EXISTING SUB-BASE GRANULAR MATERIAL, 4"
- (E5) EXISTING BASE COURSE, 9"

- (A) PROPOSED HOT-MIX ASPHALT SURFACE REMOVAL, 1 1/2"
- (B) PROPOSED HOT-MIX ASPHALT SURFACE COURSE, MIX "C", N50, 1 1/2"
- (C) PROPOSED LEVELING BINDER (MACHINE METHOD), N50, VARIABLE DEPTH
- (D) PROPOSED HOT-MIX ASPHALT BASE COURSE WIDENING, 9"
- (E) PROPOSED EARTH WEDGE

MIXTURE REQUIREMENTS

MIXTURE NUMBER:	1	2	3
LOCATIONS:	IL 106	IL 106	IL 106
MIXTURE USES:	HMA SURFACE COURSE	LEVELING BINDER	HMA BASE CS (WIDENING)
AC/PG:	PG64-22	PG64-22	PG64-22
DESIGN AIR VOIDS:	4.0% @ N DESIGN = 50	4.0% @ N DESIGN = 50	4.0% @ N DESIGN = 50
MIXTURE COMPOSITION (GRADATION MIXTURE):	IL 9.5 or 12.5	IL 9.5	IL 19.0
FRICTION AGGREGATE:	MIX "C"	N/A	N/A

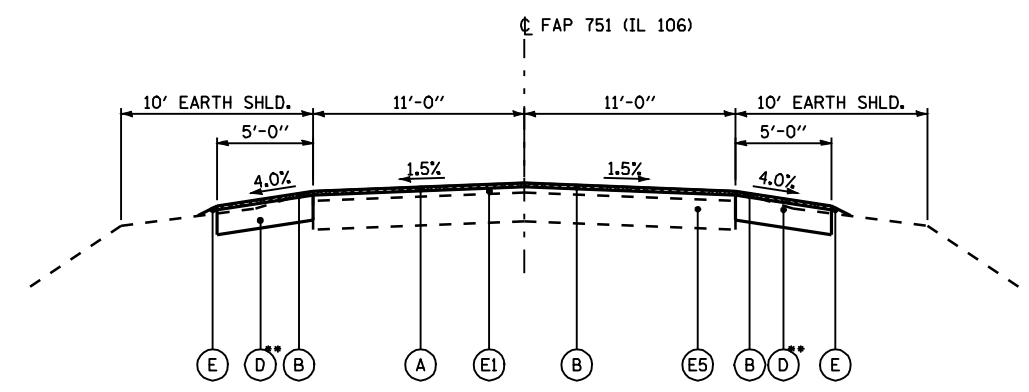

** - HMA BASE COURSE WIDENING LIMITS:
221+90.00 TO 222+73.75 RT & LT
223+21.93 TO 224+05.00 RT & LT

TYPICAL FAP 751 (IL 106) SECTION

STA 221+90.00 TO STA 222+74.25
STA 222+74.25 TO STA 223+21.43 SN 075-0004 OMISSION
STA 223+21.43 TO STA 224+05.00