

STATE OF ILLINOIS  
DEPARTMENT OF TRANSPORTATION

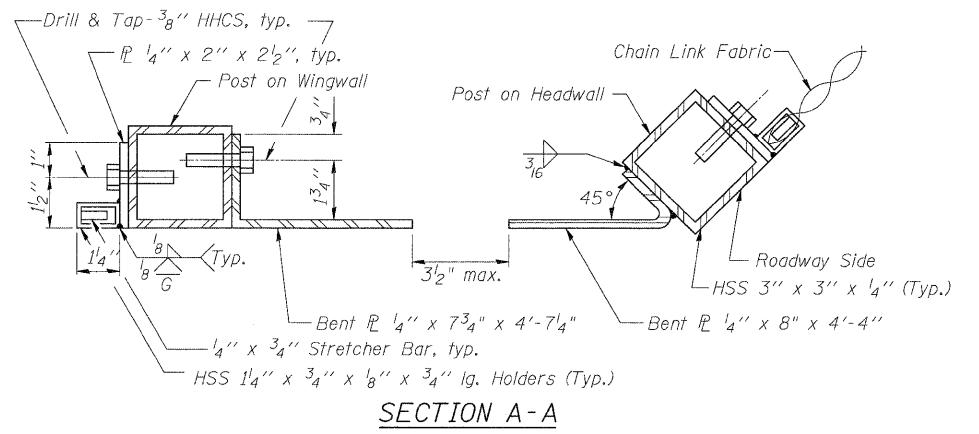
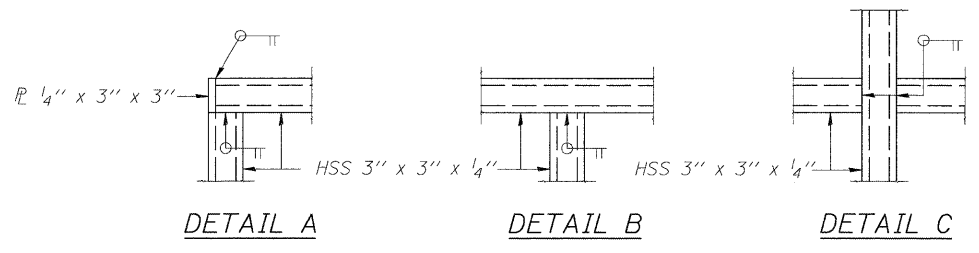
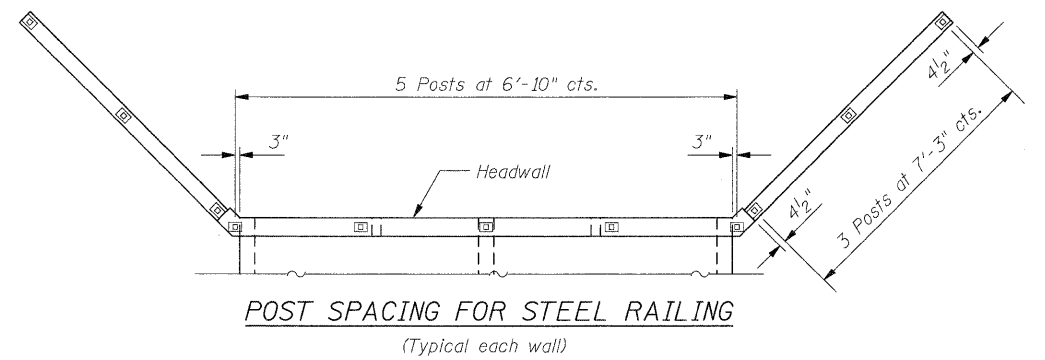
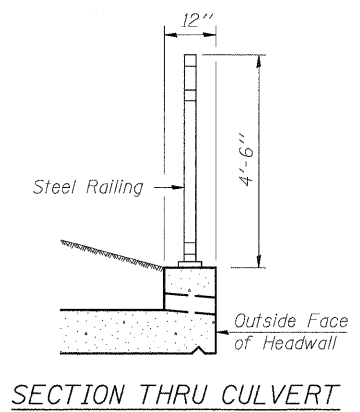
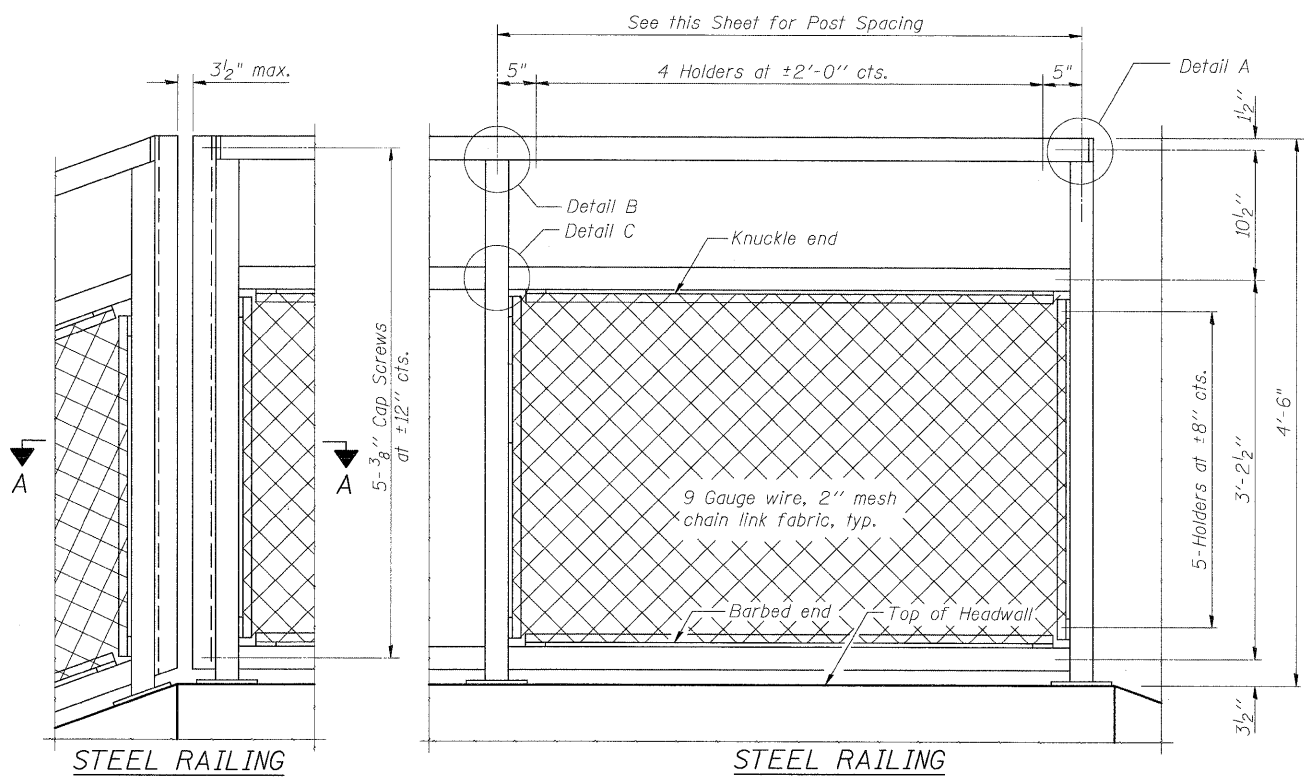

**NOTES**

Railing shall be according to Section 509 of the Standard Specifications, except as noted, and will be paid for at the Contract Unit Price per foot for Bicycle Railing.

The 9 gauge fabric ties shall be according to Article 1006.27 (d) of the Standard Specifications.

Installation of the chain link fabric shall be according to Section 664 of the Standard Specifications.

Hollow structural sections shall conform to the requirements of ASTM designation A 500, Grade B, structural steel tubing.

All other steel shapes and plates shall conform to the requirements of AASHTO M 270 Grade 36.

The chain link fabric shall be placed along Bicycle Side as shown on Section A-A.

Stretcher bars shall be used at all four sides of each panel.

If the option of drilling and epoxy grouting the anchor rods is chosen, the Contractor shall use the capsule or the adhesive cartridge type anchor rods that have been previously tested and given a prior approval by the Department. The Contractor shall install these anchor rods in pre-drilled holes according to the manufacturer's recommendations and procedures. The capsule or the adhesive cartridge shall be sealed with pre-measured amounts of the adhesive chemical.

Space reinforcement to miss anchor rods.

When railing is galvanized:

All posts, railing, splices, anchor devices, and bent plates shall be galvanized after shop fabrication according to AASHTO M 111 and ASTM A 385. All bolts, nuts, washers, and anchor rods shall be galvanized according to AASHTO M 232 except stainless steel bolts as noted.

Vent holes for galvanizing shall be placed in the posts and rails at locations that will not allow the accumulation of moisture in the members.

The chain link fabric shall conform to the requirements of Article 1006.27(a)(1), b or c of the Standard Specifications.

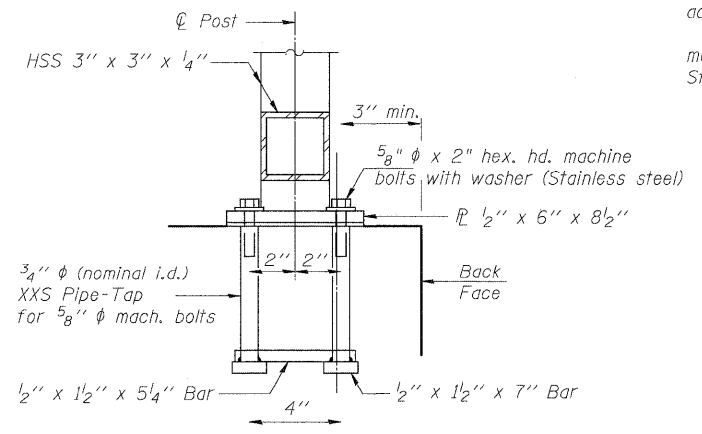
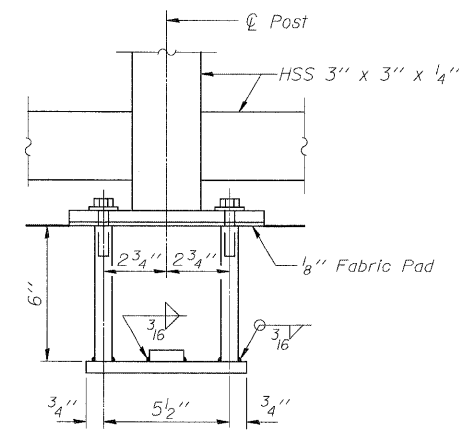
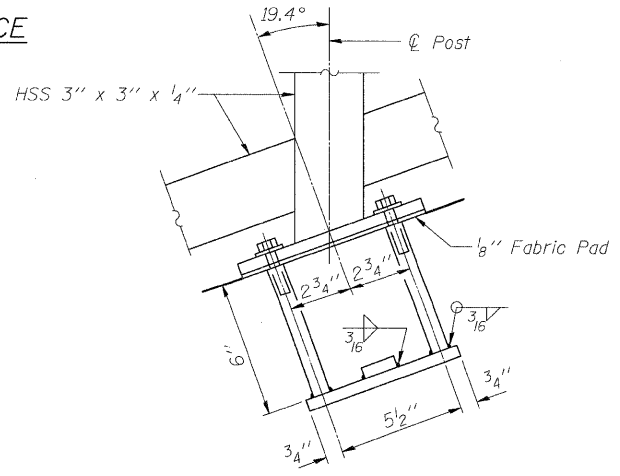
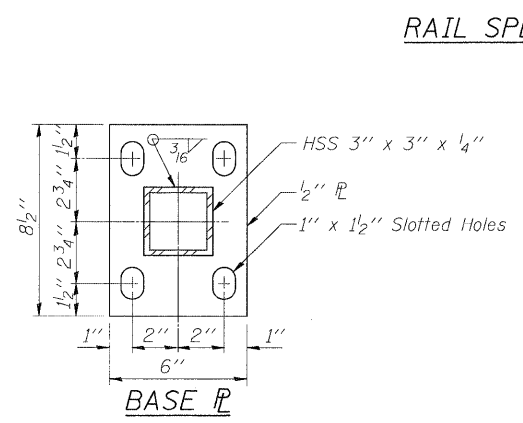
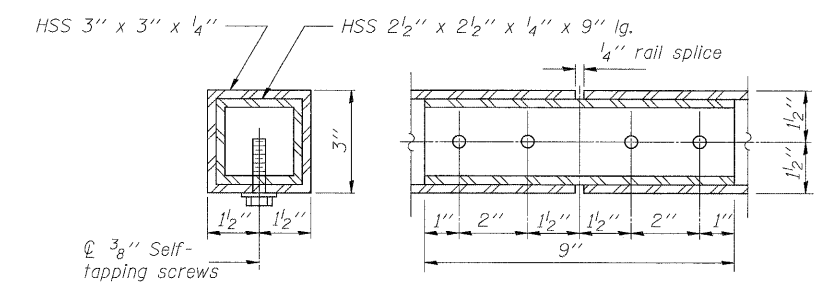

**ANCHOR BOLT DETAILS**

In lieu of the cast-in-place anchor device shown, the Contractor has the option of drilling and epoxy grouting 3/8" anchor rods. Embedment shall be according to the manufacturer's specifications.

**STEEL RAILING  
BILL OF MATERIAL**

Item	Unit	Quantity
Steel Railing (Special)	Foot	120

**STEEL RAILING DETAILS  
S.N. 026-2019**

DESIGNED SCD  
CHECKED DRB  
DRAWN THW  
CHECKED SCD

**ie** consultants  
IE CONSULTANTS, INC  
6420 SOUTH SIXTH STREET  
SPRINGFIELD, ILLINOIS 62712  
TEL (217) 529-8027  
FAX (217) 529-4543  
IESPRINGFIELD@IE-CONSULTANTS.COM  
WWW.IE-CONSULTANTS.COM

SHEET NO.	F.A. RTE.	SECTION	COUNTY	TOTAL SHEETS	SHEET NO.
6	*	114B-1(1) & 114B-1(2)	FAYETTE	54	47
OF 9 SHEETS	* F.A.P. RTE. 750, F.A.S. RTE. 719		CONTRACT NO. 74110		
FED. ROAD DIST. NO.		ILLINOIS FED. AID PROJECT			