

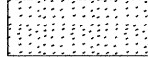

STATE OF ILLINOIS  
DEPARTMENT OF TRANSPORTATION

LEGEND

-  Hollow or Unsound Concrete
-  Spalled Concrete
-  Spalled Concrete with Exposed Reinf.
-  Hairline Crack

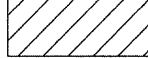

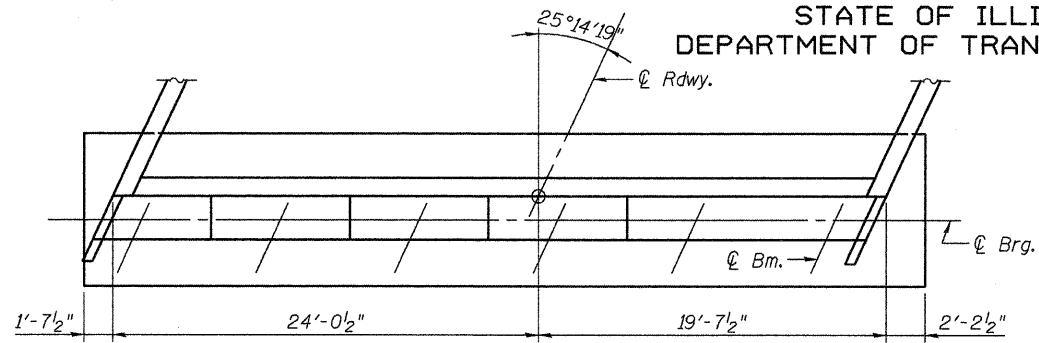
PLAN

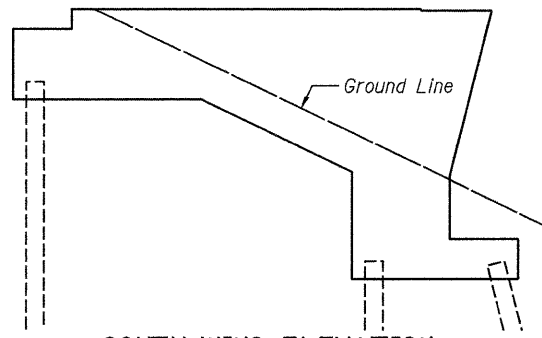

SOUTH WING ELEVATION

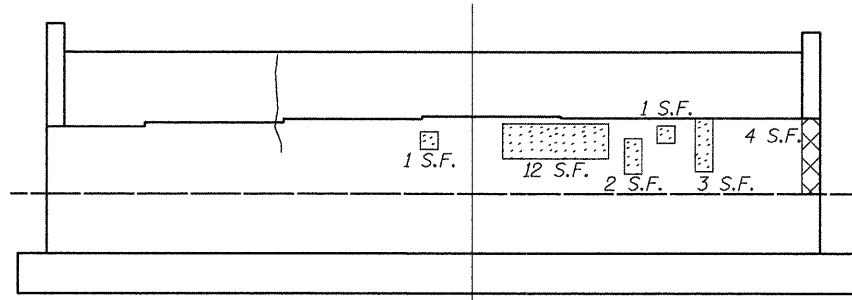

ELEVATION AT EAST ABUTMENT

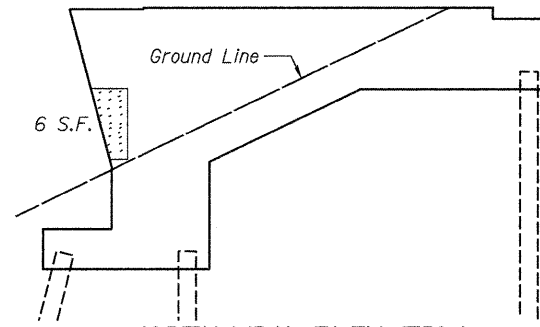

NORTH WING ELEVATION

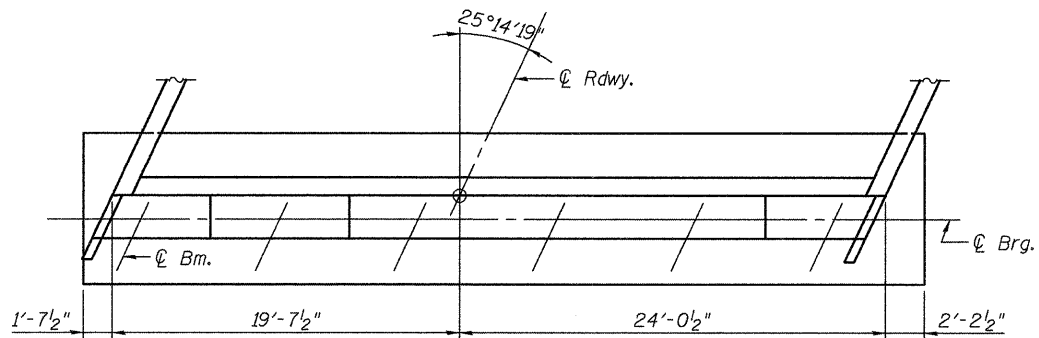

PLAN

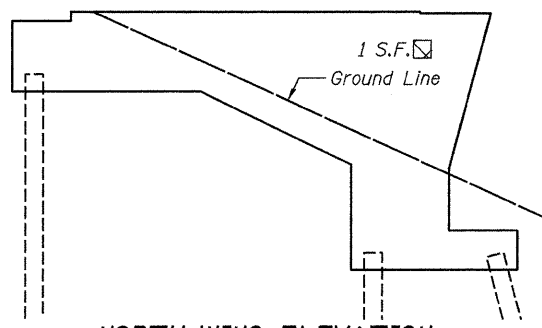

NORTH WING ELEVATION

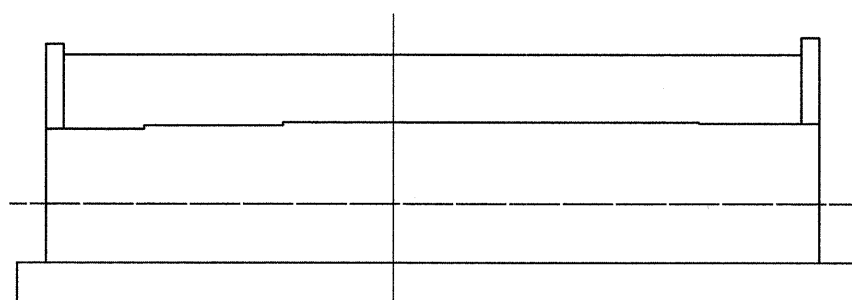

ELEVATION AT WEST ABUTMENT

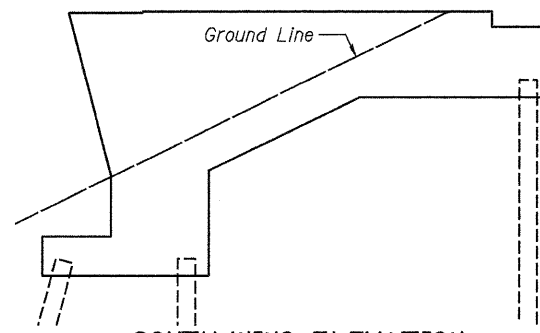

SOUTH WING ELEVATION

BILL OF MATERIAL

Item	Unit	Total
Structural Repair of Concrete (Depth = < 5")	Sq. Ft.	5

Notes:  
Condition Survey performed 9/16/2009.

Plan quantities assume that areas of "exposed reinforcing" will be repaired.

Repair areas are estimated, the Engineer shall determine actual repair locations and record them on the As-Built plans.

 Johnson, Depp & Quisenberry  
CONSULTING ENGINEERS  
Springfield, Illinois

DESIGNED: JDQ	DRAWN: SJS
CHECKED: DCD	CHECKED: DCD

ABUTMENTS (NB)  
STRUCTURE NO. 058-0104(NB) & 0105(SB)

SHEET 10 OF 11	F.A.P. RTE.	SECTION	COUNTY	TOTAL SHEETS	SHEET NO.
	322	(58-20)RS	MACON	151	101
		STA. 142+55.53	CONTRACT NO. 74150		
		FED. ROAD DIST. NO.	ILLINOIS FED. AID PROJECT		

DATE: 04/09/2010 10:51:16 USER: DCD FILE: J:\JDQ\10177 IL-DTVM\*8 USSIBridge Repairs\2-Taylor-Road\0580104-74150-010-abutms-NB.dgn