

MILLING TRANSITION DETAIL

- STA. 1310+50.00 TO STA. 1310+85.00
- STA. 1318+75.00 TO STA. 1319+10.00
- STA. 1323+91.00 TO STA. 1324+26.00
- STA. 1330+05.00 TO STA. 1330+40.00
- STA. 1359+15.00 TO STA. 1359+50.00
- STA. 1365+90.00 TO STA. 1366+25.00
- STA. 1377+03.00 TO STA. 1377+38.00
- STA. 1381+30.00 TO STA. 1381+65.00
- STA. 1384+86.00 TO STA. 1385+21.00
- STA. 1414+40.00 TO STA. 1414+75.00

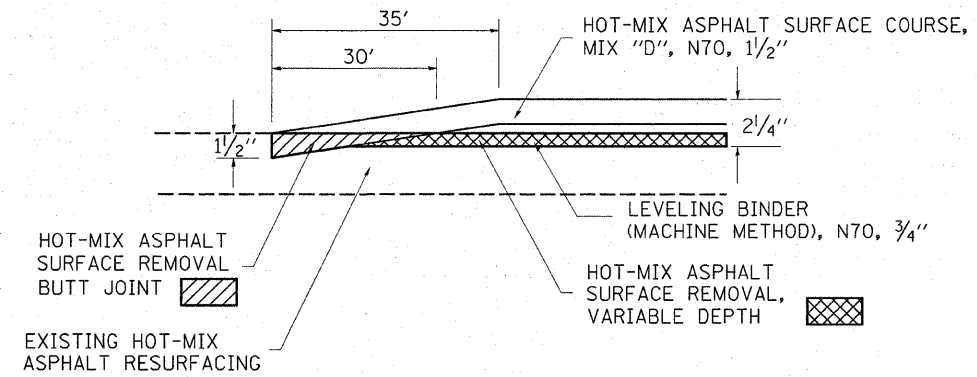

BUTT JOINT DETAIL

- STA. 1889+18.00 TO STA. 1889+53.00
- STA. 1333+50.00 TO STA. 1333+85.00
- STA. 1337+15.00 TO STA. 1337+50.00
- STA. 1342+00.00 TO STA. 1342+35.00
- STA. 1345+65.00 TO STA. 1346+00.00
- STA. 1399+75.00 TO STA. 1400+10.00

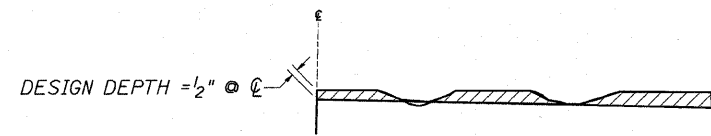

NOTES:

1. MILLING SHALL BE DONE TO ATTAIN A 3/16 "/FT. SLOPE IN CROWN SECTIONS
2. EXISTING S.E. AND S.E. TRANSITIONS SHALL BE MAINTAINED UNLESS OTHERWISE SHOWN ON THE PLANS.
3. MILLING TO THE BOTTOM OF WHEEL RUTS SHALL NOT BE NECESSARY UNLESS REQUIRED TO OBTAIN SLOPE OR THE DESIGN DEPTH AT CENTERLINE.
4. THE AVERAGE DEPTH OF MILLING IS ESTIMATED TO BE 1/2" BUT MAY VARY IN ISOLATED LOCATIONS.

HOT-MIX ASPHALT SURFACE REMOVAL (VARIABLE DEPTH) DETAIL

FILE NAME =	USER NAME = swartzrw	DESIGNED -	REVISED -	STATE OF ILLINOIS DEPARTMENT OF TRANSPORTATION	CONSTRUCTION DETAILS			F.A.S RTE.	SECTION	COUNTY	TOTAL SHEETS	SHEET NO.
c:\pwwork\pwidot\swartzrw\dms54414\sh	details_74317.dgn	DRAWN -	REVISED -					2796	(L,K)RS-2	EFFINGHAM	58	12
	PLOT SCALE = 20,0000 ' / IN.	CHECKED -	REVISED -		SCALE: NA SHEET NO. 1 OF 1 SHEETS STA. TO STA.			CONTRACT NO. 74317				
	PLOT DATE = 3/17/2018	DATE -	REVISED -		FED. ROAD DIST. NO. ILLINOIS FED. AID PROJECT							