

EXISTING TANGENT SECTION
 STA. 424+00.00 TO STA. 426+56.34
 STA. 429+99.91 TO STA. 431+00.00

- LEGEND**
- ① EXISTING PAVEMENT
 - ② EXISTING HMA SURFACE COURSE, 1 1/2"
 - ③ EXISTING HMA WIDENING
 - ④ EXISTING HMA SHOULDER
 - ⑤ PROPOSED BITUMINOUS MATERIAL (PRIME COAT)
 - ⑥ PROPOSED AGGREGATE (PRIME COAT)
 - ⑦ PROPOSED LEVELING BINDER, (MM) 3/4"
 - ⑧ PROPOSED HMA BINDER COURSE, MIX D, (VARIES 2" to 8 1/2")
 - ⑨ PROPOSED HMA SURFACE COURSE 1 1/2"
 - ⑩ PROPOSED HMA SHOULDERS
 - ⑪ PROPOSED AGGREGATE SHOULDERS, TYPE B

 HMA SURFACE REMOVAL (VARIABLE DEPTH)

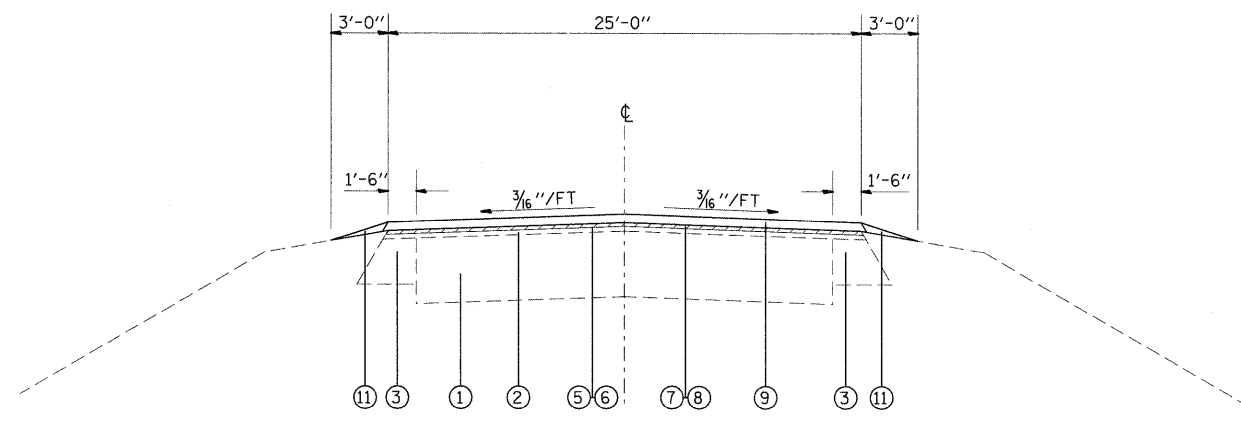

PROPOSED TANGENT SECTION
 STA. 424+00.00 TO STA. 426+56.34
 STA. 429+99.91 TO STA. 431+00.00

FILE NAME =	USER NAME = gelinh	DESIGNED -	REVISED -	STATE OF ILLINOIS DEPARTMENT OF TRANSPORTATION	TYPICAL SECTIONS	F.A.P. RTE. *	SECTION	COUNTY	TOTAL SHEETS	Rev. SHEET NO.	
ca\pw_work\FWIDOT\GELINH\d0146285\d876	8-sh-t-plan.dgn	DRAWN -	REVISED -			592	121-IRS-2	ST CLAIR	13	4	
PLOT SCALE = 50,0000' / IN.		CHECKED -	REVISED -			CONTRACT NO. 76D18					
PLOT DATE = 3/18/2010		DATE -	REVISED -			FED. ROAD DIST. NO. - ILLINOIS FED. AID PROJECT					
				SCALE: _____ SHEET NO. 1 OF 1 SHEETS STA. _____ TO STA. _____							