

TANGENT SECTION
MM 3.83 - 4.85

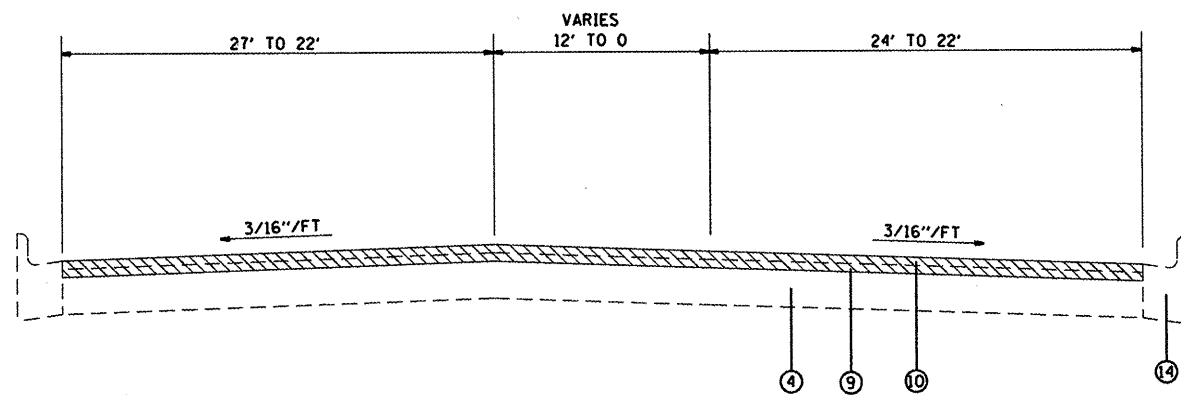

TYPICAL SECTION
MM 4.85 - 4.95

NOTE: USE A 15' TAPER TO TAKE THE MILLING FROM 1-1/2" TO 2-1/4" AT THE CURB AND GUTTER SECTION. DO NOT MILL INTO THE CONCRETE.

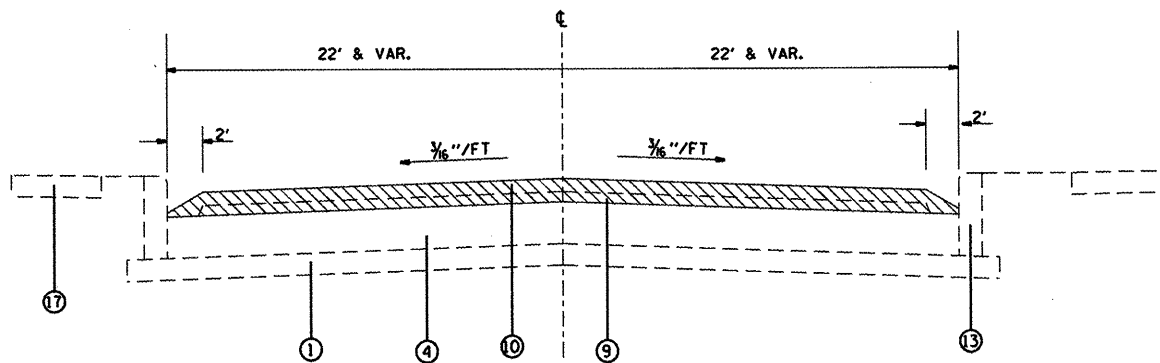

TYPICAL SECTION
MM 4.95 - 5.31
MM 6.10 - 6.36

- PROP. HMA SURFACE REMOVAL 1-1/2"
- PROP. HMA SURFACE REMOVAL 2-1/4"

LEGEND

- ① EXISTING SUBBASE GRANULAR MATERIAL, 4"
- ② EXISTING PCC BASE COURSE, 8"
- ③ EXISTING CONCRETE PAVEMENT, 10-8-10
- ④ EXISTING PCC PAVEMENT, 10"
- ⑤ EXISTING HMA RESURFACING, 3" +/-
- ⑥ EXISTING HMA SHOULDER
- ⑦ EXISTING HMA SHOULDER, 6"
- ⑧ EXISTING HMA SHOULDER OVERLAY
- ⑨ EXISTING LEVELING BINDER (MM), TYPE 2, 0.75"
- ⑩ EXISTING HMA SURFACE COURSE, MIX D, CLASS I, TYPE 2, 1.5"
- ⑪ EXISTING AGGREGATE SHOULDER
- ⑫ EXISTING AGGREGATE SHOULDER WEDGE
- ⑬ EXISTING CONCRETE CURB
- ⑭ EXISTING CCC&G, TYPE B-6.06
- ⑮ EXISTING CCC&G, TYPE B-6.24
- ⑯ EXISTING CONCRETE MEDIAN
- ⑰ EXISTING PCC SIDEWALK
- ⑱ EXISTING HMA SURFACE COURSE, VAR. DEPTH
- ⑲ EXISTING BITUMINOUS BASE COURSE, 11"
- ⑳ EXISTING CONCRETE MEDIAN SURFACE
- ㉑ EXISTING CCC&G, TYPE B-6.12

FILE NAME =	USER NAME = #USER#
#FILEL#	

DESIGNED -	REVISD -
DRAWN -	REVISD -
CHECKED -	REVISD -
PLDT DATE = #DATE#	REVISD -

DESIGNED -	REVISD -
DRAWN -	REVISD -
CHECKED -	REVISD -
DATE -	REVISD -

**STATE OF ILLINOIS
DEPARTMENT OF TRANSPORTATION**

EXISTING TYPICAL SECTIONS	
SCALE:	TO STA.
SHEET NO. 2 OF 3 SHEETS	

F.A.P. RTE.	SECTION	COUNTY	TOTAL SHEETS	SHEET NO.
582	14.5RS	MADISON	71	6
CONTRACT NO. 76D47				
FED. ROAD DIST. NO. ILLINOIS FED. AID PROJECT				