

EXISTING TYPICAL SECTION
MI STA 0.00 TO MI STA 1.59

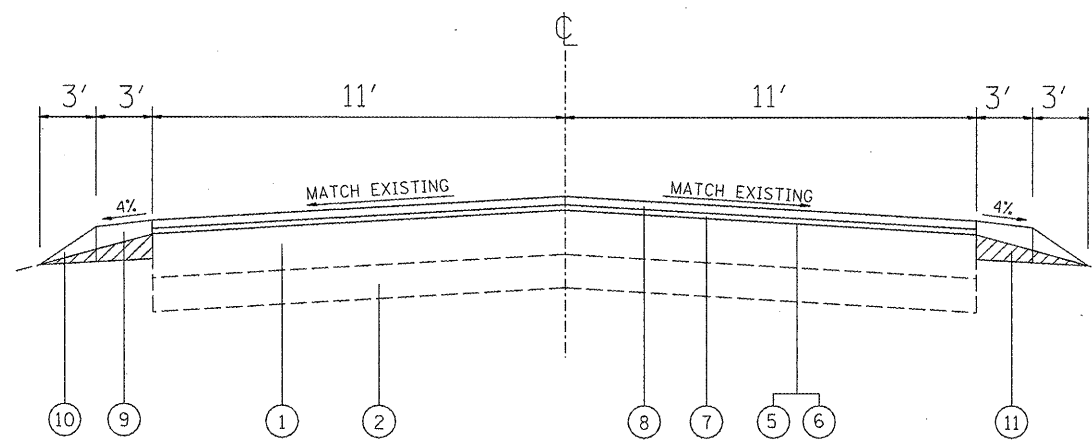

PROPOSED TYPICAL SECTION
MI STA 0.00 TO MI STA 1.59

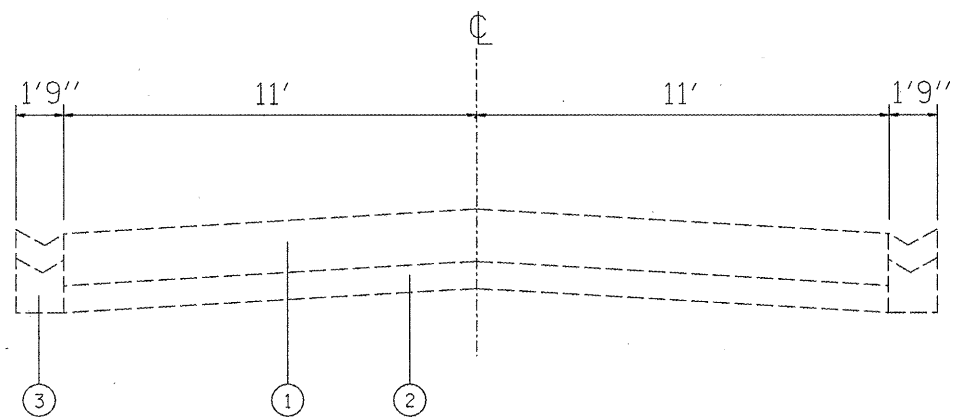

EXISTING TYPICAL SECTION
MI STA 1.59 TO MI STA 1.92

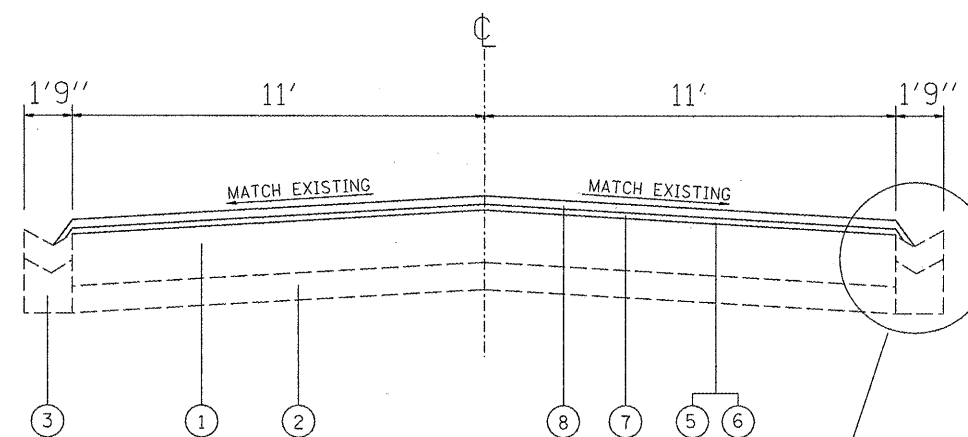

PROPOSED TYPICAL SECTION
MI STA 1.59 TO MI STA 1.92

LEGEND

- 1 EXISTING PC CONCRETE PAVEMENT, 8"
- 2 EXISTING SUBBASE GRANULAR MATERIAL TYPE A, 6"
- 3 EXISTING CONCRETE GUTTER TYPE B
- 4 EXISTING BITUMINOUS SHOULDER
- 5 PROPOSED BITUMINOUS (PRIME COAT)
- 6 PROPOSED AGGREGATE (PRIME COAT)
- 7 PROPOSED LEVELING BINDER (MACHINE METHOD) N70, 1"
- 8 PROPOSED HOT-MIX ASPHALT SURFACE COURSE, MIX D, N70, 1 1/2"
- 9 PROPOSED HOT-MIX ASPHALT SHOULDER, 6"
- 10 PROPOSED AGGREGATE WEDGE SHOULDER, TYPE B"
- 11 STABILIZED SHOULDER REMOVAL

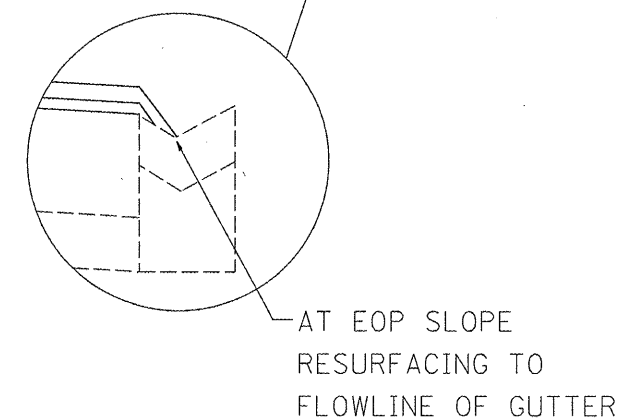

FILE NAME =	USER NAME = watersle	DESIGNED -	REVISD -
o:\p\work\PMIDOT\WATERSLE\d0174282\d876d71-shit-plan.dgn		DRAWN -	REVISD -
		CHECKED -	REVISD -
		DATE -	REVISD -

**STATE OF ILLINOIS
DEPARTMENT OF TRANSPORTATION**

TYPICAL SECTIONS

SCALE: _____ SHEET NO. 1 OF 1 SHEETS STA. _____ TO STA. _____

F.A.S. RTE.	SECTION	COUNTY	TOTAL SHEETS	SHEET NO.
735	5SR5-5	MADISON	10	4
CONTRACT NO. 76D71				
FED. ROAD DIST. NO. 8 ILLINOIS FED. AID PROJECT				