

DIAPHRAGM ELEVATION AT ABUTMENT

Concrete Side Retainer not shown for clarity,
see Structural Sheet 23B of 33B.

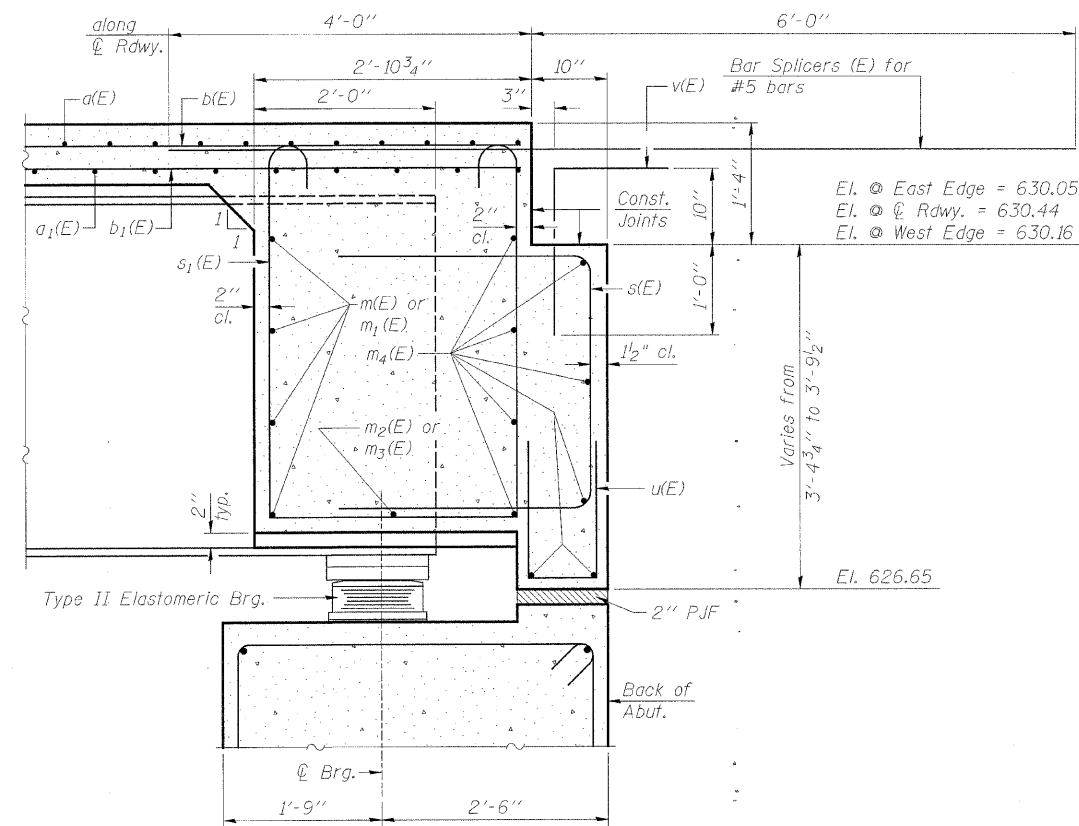

SECTION A-A

Dimensions at right angles to abutment, except as shown.

NOTES:

Reinforcement bars in diaphragm are billed with Superstructure on Structural Sheet 12B of 33B.
For bar details, see Structural Sheet 12B of 33B.
Concrete in diaphragm is included with Concrete Superstructure on Structural Sheet 12B of 33B.

MIN. BAR LAPS	
BAR	LAP
#4	2'-7"
#5	3'-3"
#6	3'-10"
#7	5'-2"
#8	6'-9"

DIAPHRAGM DETAILS - SOUTH ABUTMENT
C.H. 8 OVER IOWA INTERSTATE RAILROAD
& THE HENNEPIN CANAL
STATION 36+00
S.N. 006-3247
 WHA #1066D05

STRUCTURAL SHEET NO. 13B OF 33B SHEETS	F.A.S. RTE.	SECTION	COUNTY	TOTAL SHEETS	SHEET NO.
	188	05-00195-00-BR	BUREAU	127	79
CONTRACT NO. 87380					
FED. ROAD DIST. NO. 7 ILLINOIS FED. AID PROJECT BRS-0188(118)					