

**BITUMINOUS MIXTURE REQUIREMENTS**  
THE FOLLOWING MIXTURE REQUIREMENTS ARE APPLICABLE FOR THIS PROJECT:

MIXTURE USE(S):	SURFACE COURSE	BINDER COURSE	BINDER COURSE
AC/PG:	SBS 70-28	SBS 70-28	PG 64-22
RAP% (MAX.):	10%	10%	25%
DESIGN AIR VOIDS:	4.0% @ N-50	4.0% @ N-50	4.0% @ N-50
MIXTURE COMPOSITION: (GRADATION MIXTURE)	IL 9.5 OR IL 12.5	IL 19.0	IL 19.0
FRICTION AGGREGATE:	MIXTURE E	N.A.	N.A.
MIXTURE WEIGHT:	116 LB/SQ YD/IN	116 LB/SQ YD/IN	116 LB/SQ YD/IN
THICKNESS:	2.0 IN	2.25 IN	5.5 IN

STRUCTURAL DESIGN TRAFFIC:	YEAR 2020	ADT 15,341
PV = 96.5%	SU = 3.4%	MU = 0.1%
ROAD/STREET CLASSIFICATION:	CLASS I	
P = 50%	S = 50%	M = 50%
TRAFFIC FACTOR: ACTUAL TF =	0.79	AC TYPE = 20
MINIMUM TF =		
AC GRADE: Binder =	58-22	Surface = 64-28
SUBGRADE SUPPORT RATING:		
SSR = POOR	(STA. 85+60.00 TO 92+40.00 )	
SSR = POOR	(STA. 249+25.00 TO 261+90.00 )	

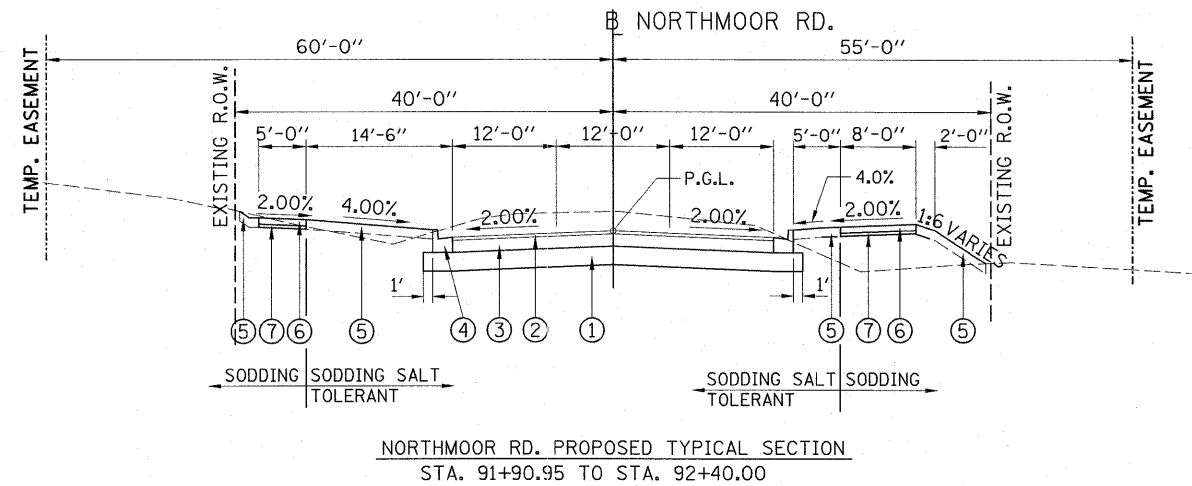

INTERSECTION OMISSION  
STA 89+23.81 TO STA 91+90.95

**LEGEND**

- ① PROPOSED SUB-BASE GRANULAR MATERIAL, TYPE A, 12"
- ② PROPOSED POLYMERIZED HOT-MIX ASPHALT SURFACE COURSE, MIX "E", N50, 2"
- ③ PROPOSED HOT-MIX ASPHALT BINDER COURSE, IL-19.0, N50, 7 3/4" (TOP 2 1/4" TO BE POLYMERIZED)
- ④ PROPOSED COMBINATION CONCRETE CURB AND GUTTER, TYPE B-6.18
- ⑤ PROPOSED TOPSOIL FURNISH AND PLACE, 6"
- ⑥ PORTLAND CEMENT CONCRETE SIDEWALK, 4"
- ⑦ PROPOSED SUB-BASE GRANULAR MATERIAL, TYPE A, 4"
- ⑧ PROPOSED HOT-MIX ASPHALT SHOULDERS, 8"

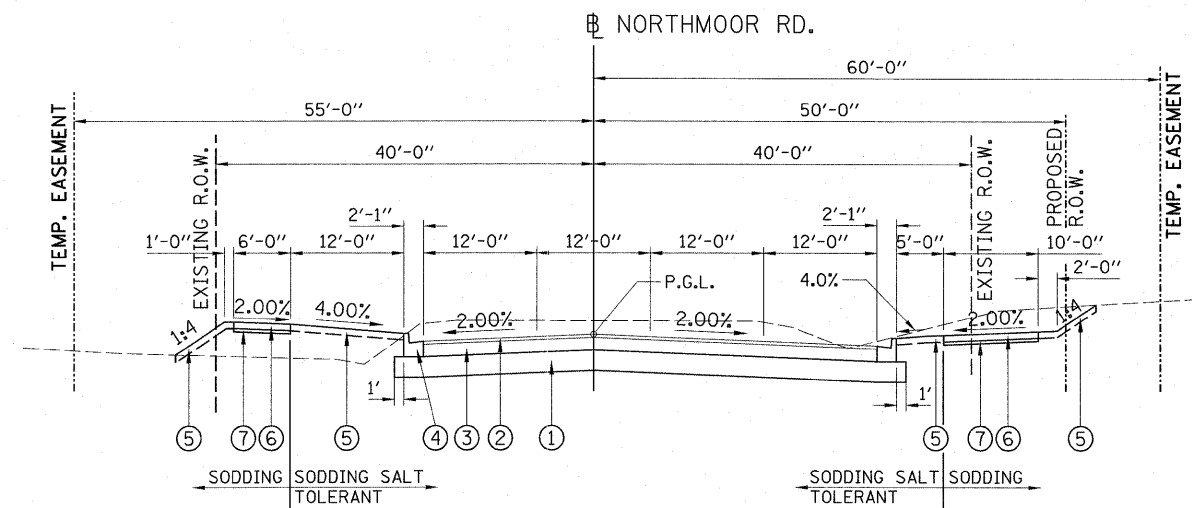

INTERSECTION OMISSION  
STA 85+60.00 TO STA 87+76.69

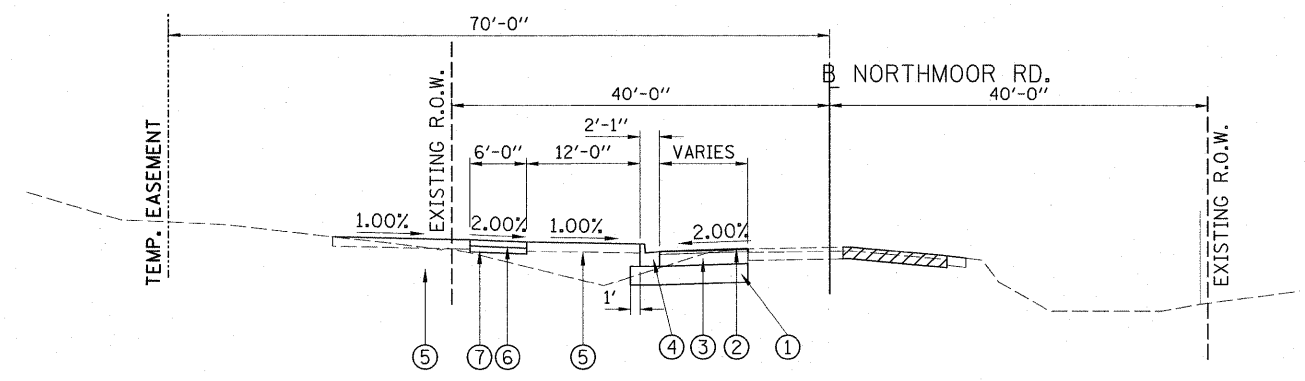
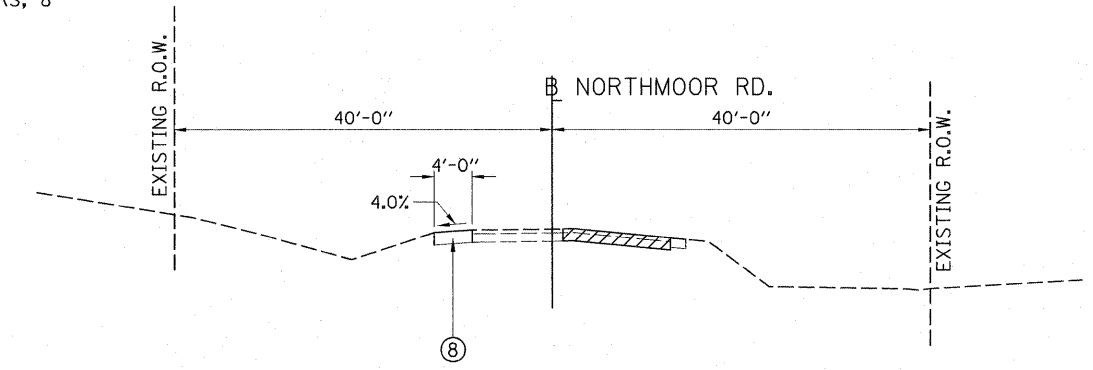

© Copyright Hanson Professional Services Inc. 2010  
**HANSON**  
 Hanson Professional Services Inc.