

COUNTY	RD. DIST.	SECTION	SHT. NO.
ADAMS	FALL CREEK	09-08111-00-BR	14 OF 14

STEEL RAILING, TYPE S-1
BRIDGE SHEET 7 OF 7

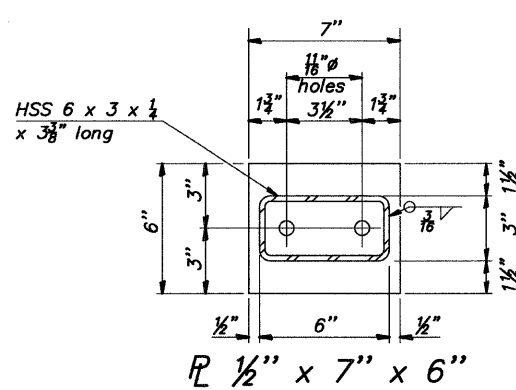
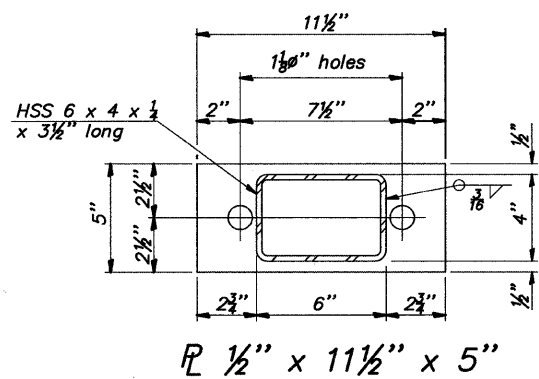
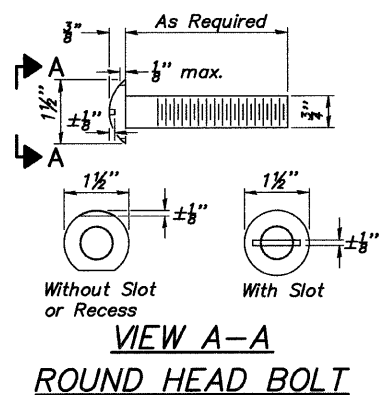

** Whenever the lower insert assemblies interfere with strand locations, the #3 bars shall be cut and adjusted in order to allow raising or lowering of the lower inserts. Maximum adjustment not to exceed 1/2".

Notes:

All field drilled holes shall be coated with an approved zinc rich paint before erection.

For multi-span bridges, sufficient 1/4" x 6" x 1'-2" galvanized steel shims shall be provided to align rail between adjacent spans. Cost included with Steel Railing, Type S-1.

All steel rail elements shall be galvanized according to Article 509.05 of the Standard Specifications.

*** The studs of the anchor devices shall be placed below the top reinforcement bars and the outermost longitudinal reinforcement bar shall be placed directly above the studs of the rail post anchor device.

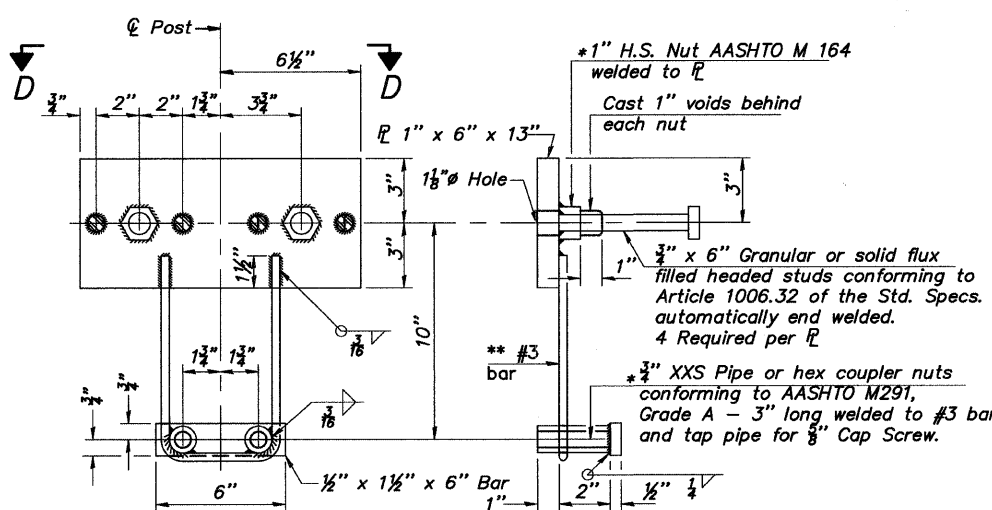
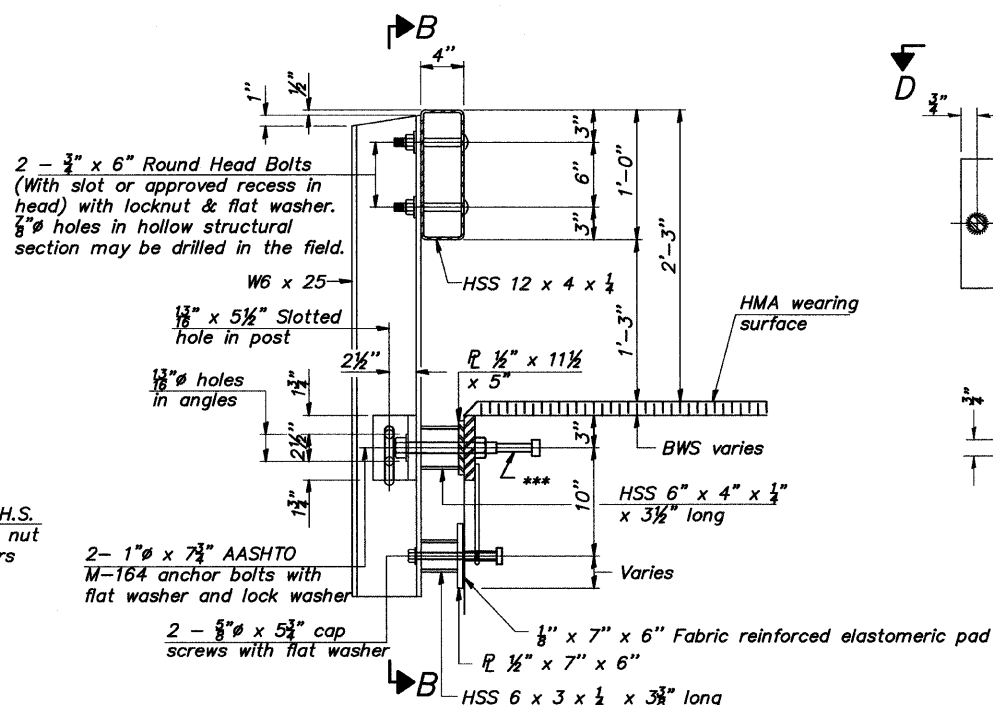
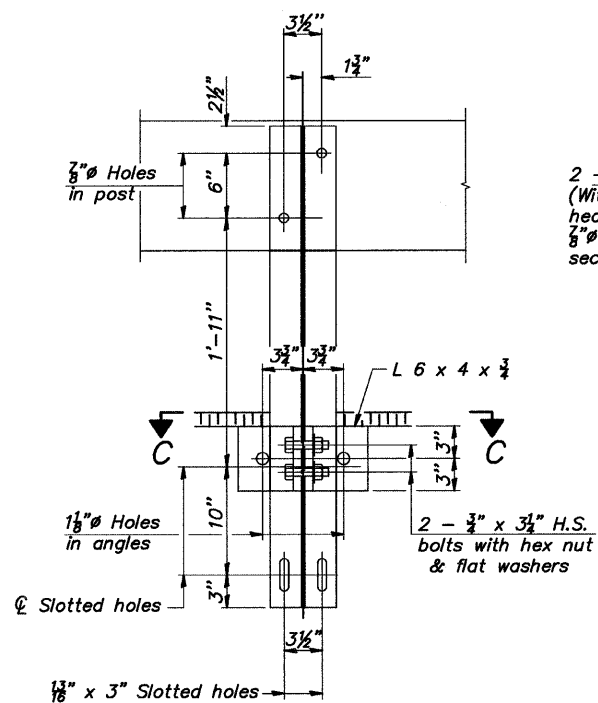

* Threaded areas shall be plugged or blocked off during casting of beam.

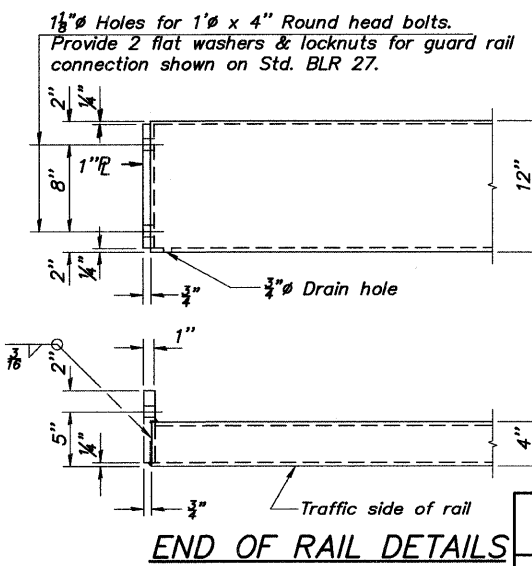
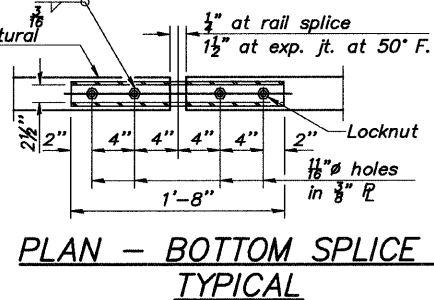
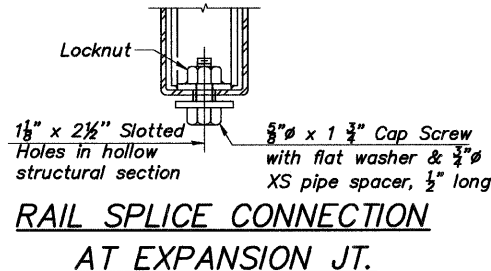
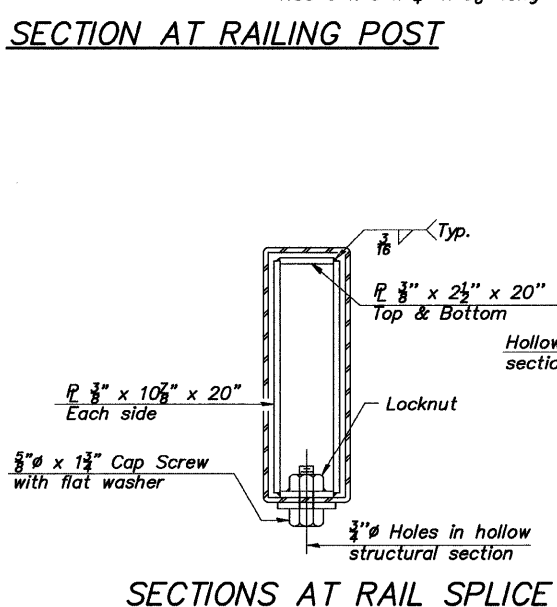
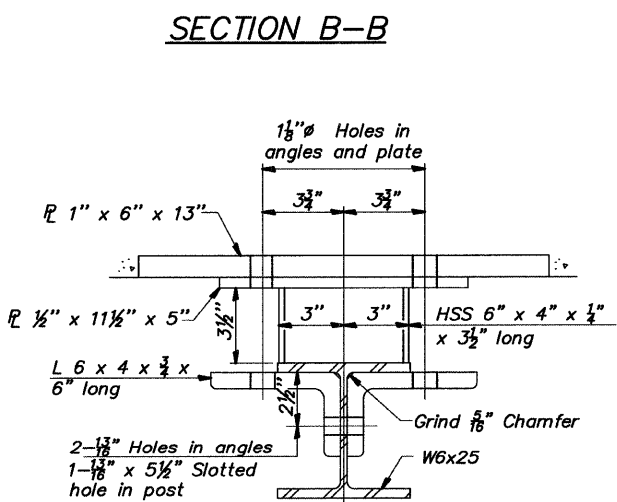
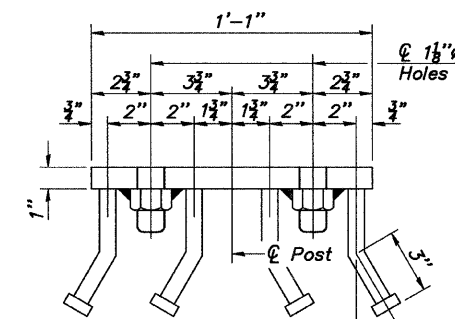

BILL OF MATERIAL

Item	Unit	Quantity
Steel Railing, Type S-1	Foot	90

STEEL RAILING, TYPE S-1
STRUCTURE NO. 001-3430
HARKNESS CREEK
ADAMS COUNTY
FALL CREEK SEC. 09-08111-00-BR
STATION 2+61.20