

**FABRIC BEARING PAD**  
(Interior)

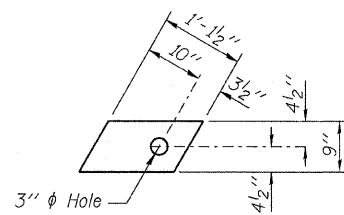

**FABRIC BEARING PAD**  
(Exterior)

**FIXED**

Note: Omit holes when using expansion bearings.

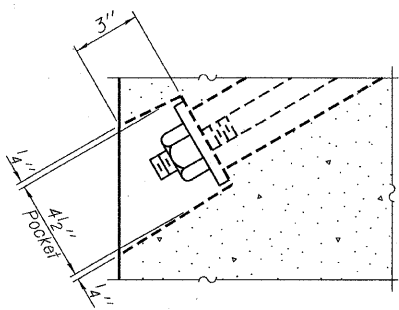

**SECTION A-A**

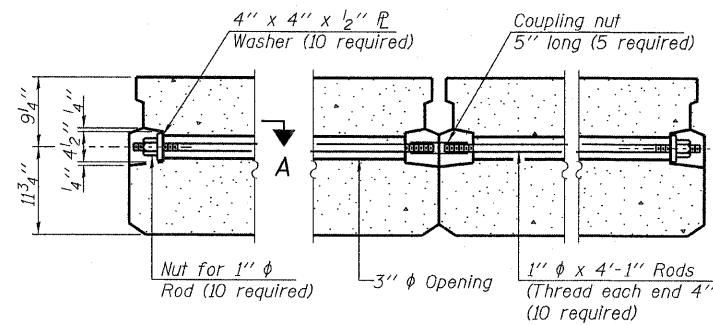

**TYPICAL TRANSVERSE TIE ASSEMBLY**

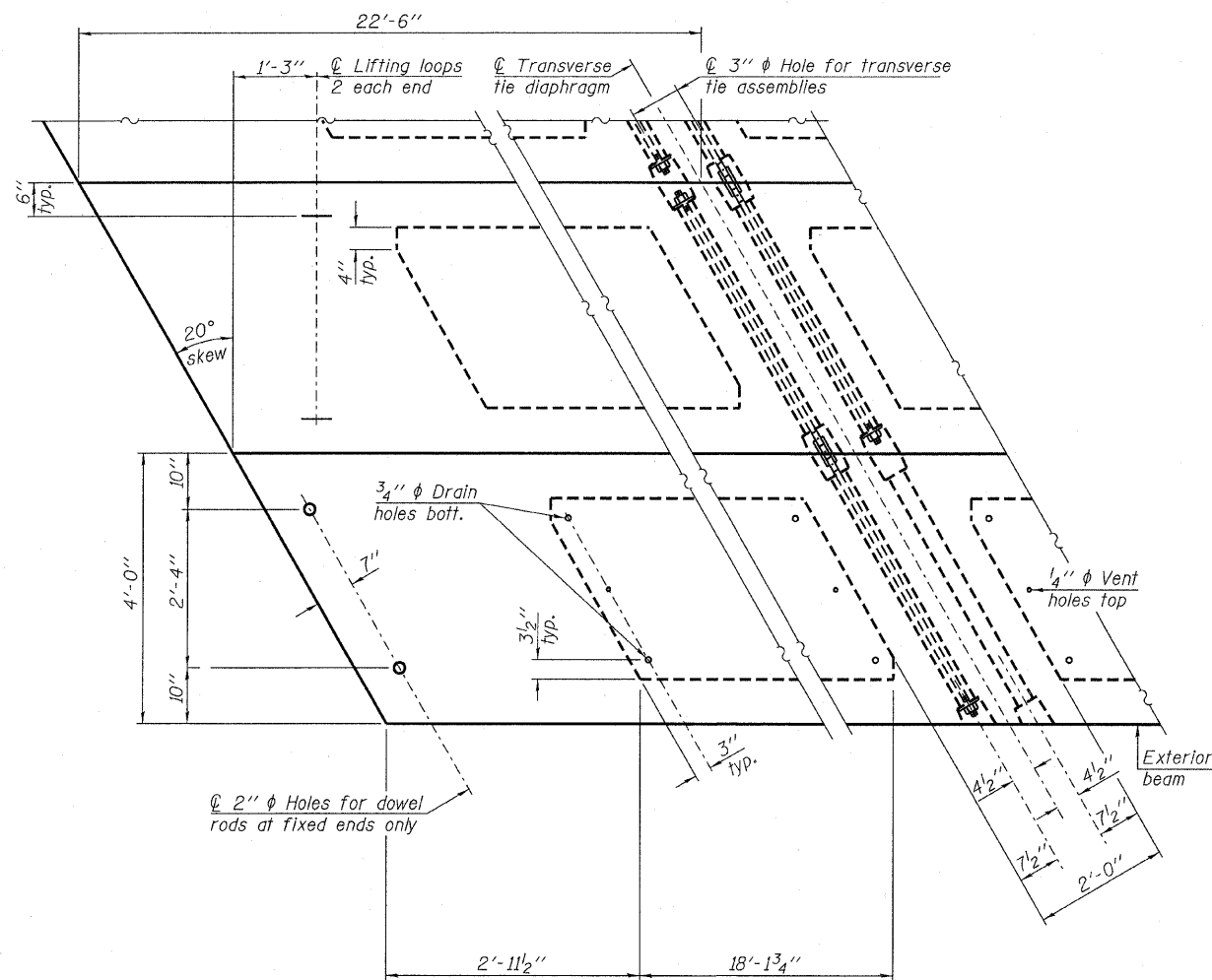

**PLAN VIEW**

**NOTES**

Prestressing steel shall be uncoated high strength, low relaxation 7-wire strand, Grade 270. The nominal diameter shall be 1/2" and the nominal cross-sectional area shall be 0.153 sq. in.  
 The 1" phi rods in the transverse tie assembly shall be tightened to a snug fit and the threads set. Pockets on exterior faces of bridge shall be filled with grout after transverse tie assembly is in place.  
 Reinforcement bars shall conform to ASTM A 706, Grade 60. (See Special Provisions).  
 Two 1/8" fabric adjusting shims of the dimensions of the exterior bearing pad shall be provided for each bearing pad location.  
 A minimum 2 1/2" phi lifting pin shall be used to engage the lifting loops during handling.  
 Corrosion Inhibitor, per Article 1020.05(b)(12) and 1021.06 of the Standard Specifications, shall be used in the concrete for precast prestressed concrete deck beams.  
 Compressive strength of prestressed concrete, f'c, shall be 6000 psi.  
 Compressive strength of prestressed concrete at release, f'cl, shall be 5000 psi.

Note: Connect beams in pairs with the transverse tie configuration shown.

DESIGNED - V.J.H.
CHECKED - S.W.M.
DRAWN - D.T.M.
CHECKED - D.A.B.

PD-2148-RD

10-1-08

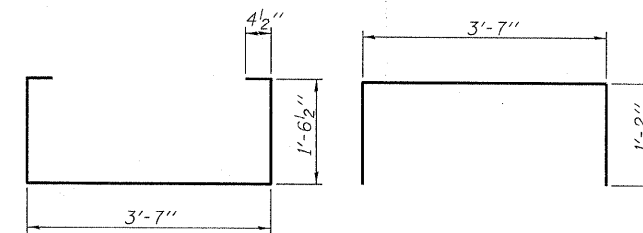

**BAR S1(E)**

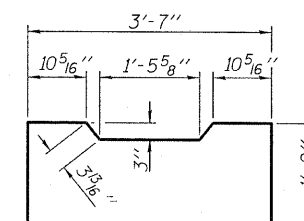

**BAR S2(E)**

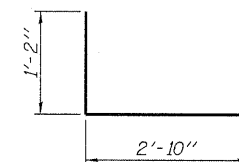

**BAR S4(E)**

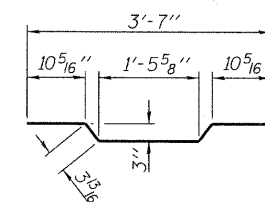

**BAR A1(E)**

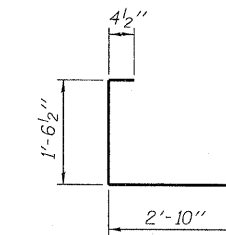

**BAR S3(E)**

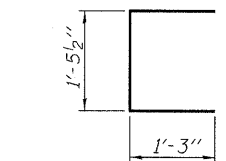

**BAR U1(E)**

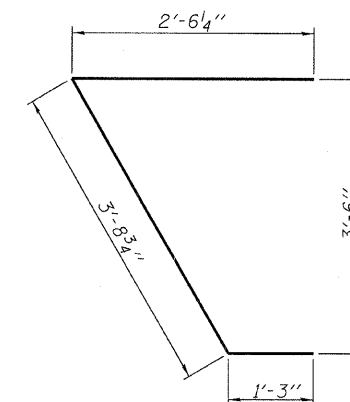

**BAR U1(E)**

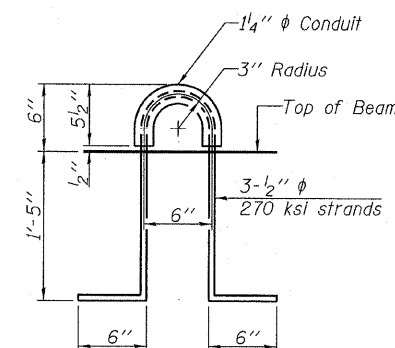

**LIFTING LOOP DETAIL**

**BILL OF MATERIAL**

Precast Prestressed Conc. Deck Bms. (21" depth)	Sq. Ft.	1,080
---	---------	-------

**SUPERSTRUCTURE**  
**21" X 48" PPC DECK BEAM DETAILS**  
**STRUCTURE NO. 033-3302**

<b>HAMPTON, LENZINI AND RENWICK, INC.</b> CIVIL ENGINEERS - STRUCTURAL ENGINEERS - LAND SURVEYORS 3085 STEVENSON DRIVE, SUITE 201 SPRINGFIELD, ILLINOIS 62703 217.546.3400 www.hlrengineering.com 184.000959 ILLINOIS PROFESSIONAL DESIGN FIRM LS / PE / SE CORPORATION PROJECT NUMBER: 09.0070.130 DATE: 12/17/09	SHEET NO. 3  8 SHEETS	T.R.	SECTION	COUNTY	TOTAL SHEETS	SHEET NO.
		52	06-04126-00-BR	HAMILTON	11	6
DAHLGREN ROAD DISTRICT			CONTRACT NO. 99416			
FED. ROAD DIST. NO.		ILLINOIS FED. AID PROJECT: BROS-065(048)				