



Illinois Department of Transportation

Memorandum

To: Carl Puzey Attn: Brad Hessing
From: Michael A. Short By: Jeremy Brown *JB*
Subject: Structure Geotechnical Report Disposition *
Date: August 31, 2020

* SN: 046-0161
Route: FAP 41
Section: (12)BR
County: Kankakee
Contract No.: 66970

Attached is the Structure Geotechnical Report for the subject project.

This disposition is to provide revisions to the SGR for SN: 046-0161 which was submitted to the Bureau of Bridges and Structures for review by Mark Jones of McCleary Engineering. These revisions are being provided by Jeremy Brown (IDOT D3 Geotechnical Engineer). The first three responses below are direct responses to the speed letter that was provided from the Bridge Office. The remaining items are additional corrections that are being made.

1. It is no longer recommended to core to bedrock and socket the H-piles in rock. It is recommended to drive H-piles to refusal in the underlying limestone layer.
2. We have revised the Integral Abutment Feasibility Spreadsheet and have determined integral abutments are feasible without the need to precore. The updated spreadsheet is attached.
3. Rock sockets are no longer recommended for the proposed H-piles. It is recommended to drive H-piles to refusal in bedrock utilizing pile shoes. We have updated the IDOT Static Method of Estimating Pile Length spreadsheet. Due to the similarity of the pile cutoff elevations and the subsurface conditions, the data from the east abutment is being used to represent both abutments. Due to the consistency of the top of rock elevations, it is recommended to not include test piles, but instead to assume a pile length of 30 feet (26 feet plus 4 feet for variation in top or rock elevations).
4. We have updated the Seismic Site Class Determination Spreadsheet. The updated spreadsheet is attached.
5. There was an error found in one of the boring logs in the original report. The updated boring logs are attached.

If you have any questions, please contact Jeremy Brown at 815-433-7098.

SUBSTRUCTURE===== **Abutments (2019)**
 REFERENCE BORING ===== **01 sta 967+18 16LT**
 LRFD or ASD or SEISMIC ===== **LRFD**
 PILE CUTOFF ELEV. ===== **613.59** ft
 GROUND SURFACE ELEV. AGAINST PILE DURING DRIVING = **611.59** ft
 GEOTECHNICAL LOSS TYPE (None, Scour, Liquef., DD) ===== **None**
 BOTTOM ELEV. OF SCOUR, LIQUEF., or DD ===== ft
 TOP ELEV. OF LIQUEF. (so layers above apply DD) ===== ft

TOTAL FACTORED SUBSTRUCTURE LOAD ===== **1920** kips
 TOTAL LENGTH OF SUBSTRUCTURE (along skew)===== **38.83** ft
 NUMBER OF ROWS OF PILES PER SUBSTRUCTURE ===== **1**
 Approx. Factored Loading Applied per pile at 8 ft. Cts ===== 395.57 KIPS
 Approx. Factored Loading Applied per pile at 3 ft. Cts ===== 148.34 KIPS

MAX. REQUIRED BEARING & RESISTANCE for Selected Pile, Soil Profile, & Losses

Maximum Nominal Req'd Bearing of Pile	Maximum Nominal Req'd Bearing of Boring	Maximum Factored Resistance Available in Boring	Maximum Pile Driveable Length in Boring
335 KIPS	288 KIPS	158 KIPS	27 FT.

PILE TYPE AND SIZE ===== **Steel HP 10 X 42**
 Plugged Pile Perimeter===== 3.300 FT. Unplugged Pile Perimeter===== 4.858 FT.
 Plugged Pile End Bearing Area===== 0.680 SQFT. Unplugged Pile End Bearing Area===== 0.086 SQFT.

BOT. OF LAYER ELEV. (FT.)	LAYER THICK. (FT.)	UNCONF. COMPR. STRENGTH (TSF)	S.P.T. N VALUE (BLOWS)	GRANULAR OR ROCK LAYER DESCRIPTION	NOMINAL PLUGGED			NOMINAL UNPLUG'D			NOMINAL REQ'D BEARING (KIPS)	FACTORED GEOTECH. LOSS FROM SCOUR or DD (KIPS)	FACTORED GEOTECH. LOSS LOAD FROM DD (KIPS)	FACTORED RESISTANCE AVAILABLE (KIPS)	ESTIMATED PILE LENGTH (FT.)
					SIDE RESIST. (KIPS)	END BRG. RESIST. (KIPS)	TOTAL RESIST. (KIPS)	SIDE RESIST. (KIPS)	END BRG. RESIST. (KIPS)	TOTAL RESIST. (KIPS)					
608.68	2.91	1.50	3		9.2	28.3	13.6	13.6	16.0	16	0	0	9	5	
606.18	2.50	2.00	7		9.6	19.1	37.9	14.1	2.4	30.1	30	0	17	7	
604.18	2.00	2.00	3		7.7	19.1	76.1	11.3	2.4	45.3	45	0	25	9	
601.68	2.50	5.20	12		17.1	49.6	89.4	25.2	6.3	70.1	70	0	39	12	
599.18	2.50	4.80	13		17.1	45.8	108.5	25.2	5.8	95.6	96	0	53	14	
596.68	2.50	5.00	14		17.1	47.7	141.9	25.2	6.0	122.9	123	0	68	17	
594.18	2.50	6.70	20		17.1	63.9	138.3	25.2	8.1	145.5	138	0	76	19	
591.68	2.50		34	Hard Till	3.1	43.2	180.8	4.5	5.5	155.0	155	0	85	22	
589.18	2.50		85	Hard Till	8.1	82.6	253.8	11.9	10.5	175.2	175	0	96	24	
588.68	0.50		116	Hard Till	4.7	147.5	258.5	7.0	18.7	182.1	182	0	100	25	
588.18	0.50		116	Hard Till	4.7	147.5	263.2	7.0	18.7	189.1	189	0	104	25	
587.68	0.50		116	Hard Till	4.7	147.5	267.9	7.0	18.7	196.0	196	0	108	26	
587.18	0.50		116	Hard Till	4.7	147.5	272.7	7.0	18.7	203.0	203	0	112	26	
586.68	0.50		116	Hard Till	4.7	147.5	892.7	7.0	18.7	287.8	288	0	158	27	
586.18	0.50		600	Hard Till	124.7	762.8	1017.4	183.6	96.5	471.4	471	0	269	27	
585.68	0.50		600	Hard Till	124.7	762.8	1142.1	183.6	96.5	655.0	655	0	360	28	
585.18	0.50		600	Hard Till	124.7	762.8	673.6	183.6	96.5	763.6	674	0	370	28	
584.68	0.50			Limestone	41.1	169.5	714.7	60.5	21.5	824.1	745	0	393	28.9	
584.18	0.50			Limestone	41.1	169.5	755.8	60.5	21.5	884.6	756	0	416	29.4	
583.68	0.50			Limestone	41.1	169.5	796.9	60.5	21.5	945.1	797	0	438	29.9	
583.18	0.50			Limestone	41.1	169.5	838.0	60.5	21.5	1005.6	838	0	461	30.4	
582.68	0.50			Limestone	41.1	169.5	879.1	60.5	21.5	1066.2	879	0	484	30.9	
582.18	0.50			Limestone	41.1	169.5	920.2	60.5	21.5	1126.7	920	0	506	31.4	
581.68	0.50			Limestone	41.1	169.5	961.3	60.5	21.5	1187.2	961	0	529	31.9	
581.18	0.50			Limestone	41.1	169.5	1002.4	60.5	21.5	1247.7	1002	0	551	32.4	
580.68	0.50			Limestone	41.1	169.5	1043.6	60.5	21.5	1308.3	1044	0	574	32.9	
580.18	0.50			Limestone		169.5			21.5			0			



SOIL BORING LOG

ROUTE SBI-17 (IL 17) DESCRIPTION IL 17 over East Branch of Horse Creek, 0.2 miles East of Herscher Road LOGGED BY W. Carter

SECTION 12-BR LOCATION SE 1/4, SEC. 32, TWP. 31N, RNG. 10E, 3rd PM,
Latitude , Longitude

COUNTY Kankakee DRILLING METHOD _____ HAMMER TYPE _____

STRUCT. NO. <u>046-0032 (Exist.)</u>	D E P T H H	B L O W S	U C S Qu	M O I S T T	Surface Water Elev. _____ ft	D E P T H H	B L O W S	U C S Qu	M O I S T T
Station <u>965+84.5</u>					Stream Bed Elev. _____ ft				
BORING NO. <u>2</u>	ft (ft)	(/6")	(tsf)	(%)	Groundwater Elev.: _____	(ft)	(/6")	(tsf)	(%)
Station <u>965+27</u>					First Encounter _____ ft				
Offset <u>18.0 ft Lt.</u>					Upon Completion _____ ft				
Ground Surface Elev. <u>615.40</u>					After _____ Hrs. _____ ft				

Soil Description	Depth (ft)	Blow Count (/6")	UCS (tsf)	Moisture (%)	Soil Description	Depth (ft)	Blow Count (/6")	UCS (tsf)	Moisture (%)
Stiff Black and Brown Silty Sandy Clay	0 - 606.50				Gray Broken Limestone	595.20 - 591.00			
	606.50 - 603.50	10	1.6		End of Boring	-25			
Hard Gray Clay Till	603.50 - 601.00	14	4.1						
Hard Gray Silty Till	601.00 - 598.50	65	4.7						
Hard Gray Sandy Clay Till	598.50 - 594.50	67	6.1						
Brittle Very Stiff Gray Sandy Clay Till	594.50 - 590.50	64	3.9						
	590.50 - 586.50								
	586.50 - 582.50								
	582.50 - 578.50								
	578.50 - 574.50								
	574.50 - 570.50								
	570.50 - 566.50								
	566.50 - 562.50								
	562.50 - 558.50								
	558.50 - 554.50								
	554.50 - 550.50								
	550.50 - 546.50								
	546.50 - 542.50								
	542.50 - 538.50								
	538.50 - 534.50								
	534.50 - 530.50								
	530.50 - 526.50								
	526.50 - 522.50								
	522.50 - 518.50								
	518.50 - 514.50								
	514.50 - 510.50								
	510.50 - 506.50								
	506.50 - 502.50								
	502.50 - 498.50								
	498.50 - 494.50								
	494.50 - 490.50								
	490.50 - 486.50								
	486.50 - 482.50								
	482.50 - 478.50								
	478.50 - 474.50								
	474.50 - 470.50								
	470.50 - 466.50								
	466.50 - 462.50								
	462.50 - 458.50								
	458.50 - 454.50								
	454.50 - 450.50								
	450.50 - 446.50								
	446.50 - 442.50								
	442.50 - 438.50								
	438.50 - 434.50								
	434.50 - 430.50								
	430.50 - 426.50								
	426.50 - 422.50								
	422.50 - 418.50								
	418.50 - 414.50								
	414.50 - 410.50								
	410.50 - 406.50								
	406.50 - 402.50								
	402.50 - 398.50								
	398.50 - 394.50								
	394.50 - 390.50								
	390.50 - 386.50								
	386.50 - 382.50								
	382.50 - 378.50								
	378.50 - 374.50								
	374.50 - 370.50								
	370.50 - 366.50								
	366.50 - 362.50								
	362.50 - 358.50								
	358.50 - 354.50								
	354.50 - 350.50								
	350.50 - 346.50								
	346.50 - 342.50								
	342.50 - 338.50								
	338.50 - 334.50								
	334.50 - 330.50								
	330.50 - 326.50								
	326.50 - 322.50								
	322.50 - 318.50								
	318.50 - 314.50								
	314.50 - 310.50								
	310.50 - 306.50								
	306.50 - 302.50								
	302.50 - 298.50								
	298.50 - 294.50								
	294.50 - 290.50								
	290.50 - 286.50								
	286.50 - 282.50								
	282.50 - 278.50								
	278.50 - 274.50								
	274.50 - 270.50								
	270.50 - 266.50								
	266.50 - 262.50								
	262.50 - 258.50								
	258.50 - 254.50								
	254.50 - 250.50								
	250.50 - 246.50								
	246.50 - 242.50								
	242.50 - 238.50								
	238.50 - 234.50								
	234.50 - 230.50								
	230.50 - 226.50								
	226.50 - 222.50								
	222.50 - 218.50								
	218.50 - 214.50								
	214.50 - 210.50								
	210.50 - 206.50								
	206.50 - 202.50								
	202.50 - 198.50								
	198.50 - 194.50								
	194.50 - 190.50								
	190.50 - 186.50								
	186.50 - 182.50								
	182.50 - 178.50								
	178.50 - 174.50								
	174.50 - 170.50								
	170.50 - 166.50								
	166.50 - 162.50								
	162.50 - 158.50								
	158.50 - 154.50								
	154.50 - 150.50								
	150.50 - 146.50								
	146.50 - 142.50								
	142.50 - 138.50								
	138.50 - 134.50								
	134.50 - 130.50								
	130.50 - 126.50								
	126.50 - 122.50								
	122.50 - 118.50								
	118.50 - 114.50								
	114.50 - 110.50								
	110.50 - 106.50								
	106.50 - 102.50								
	102.50 - 98.50								
	98.50 - 94.50								
	94.50 - 90.50								
	90.50 - 86.50								
	86.50 - 82.50								
	82.50 - 78.50								
	78.50 - 74.50								
	74.50 - 70.50								
	70.50 - 66.50								
	66.50 - 62.50								
	62.50 - 58.50								
	58.50 - 54.50								
	54.50 - 50.50								
	50.50 - 46.50								
	46.50 - 42.50								
	42.50 - 38.50								
	38.50 - 34.50								
	34.50 - 30.50								
	30.50 - 26.50								
	26.50 - 22.50								
	22.50 - 18.50								
	18.50 - 14.50								
	14.50 - 10.50								
	10.50 - 6.50								
	6.50 - 2.50								
	2.50 - 0.00								

SOIL BORING 0



SOIL BORING LOG

ROUTE SBI-17 (IL 17) DESCRIPTION IL 17 over East Branch of Horse Creek, 0.2 miles East of Herscher Road LOGGED BY W. Carter

SECTION 12-BR LOCATION NW 1/4, SEC. 4, TWP. 30N, RNG. 10E, 3rd PM,
 Latitude , Longitude

COUNTY Kankakee DRILLING METHOD _____ HAMMER TYPE _____

STRUCT. NO. <u>046-0032 (Exist.)</u>	D E P T H	B L O W S	U C S Qu	M O I S T	Surface Water Elev. _____ ft	D E P T H	B L O W S	U C S Qu	M O I S T
Station <u>965+84.5</u>					Stream Bed Elev. _____ ft				
BORING NO. <u>3</u>	ft (ft)	(/6")	(tsf)	(%)	Groundwater Elev.: _____	(ft)	(/6")	(tsf)	(%)
Station <u>965+59</u>					First Encounter _____ ft				
Offset <u>40.0 ft Rt.</u>					Upon Completion _____ ft				
Ground Surface Elev. <u>612.60</u>					After _____ Hrs. _____ ft				

Soil Description	Depth (ft)	Blows (/6")	UCS (tsf)	Moist (%)	Soil Description	Depth (ft)	Blows (/6")	UCS (tsf)	Moist (%)
Stiff to Very Stiff Black and Brown Silty Sandy Clay	0 to 604.00				Gray Limestone (continued)	0 to 591.20			
	604.00				End of Boring	591.20			
Hard Gray Silty Till	604.00 to 600.50	55	7.0						
Hard Gray Sandy Clay Till	600.50 to 598.50	49	4.3						
Very Stiff Gray Sandy Very Stony Till	598.50 to 595.20	57	3.1						
Gray Limestone	595.20 to 20								

SOIL BORING 046-0032.GPJ IL_DOT.GDT 9/4/20

The Unconfined Compressive Strength (UCS) Failure Mode is indicated by (B-Bulge, S-Shear, P-Penetrometer)
 The SPT (N value) is the sum of the last two blow values in each sampling zone (AASHTO T206)



SOIL BORING LOG

ROUTE SBI-17 (IL 17) DESCRIPTION IL 17 over East Branch of Horse Creek, 0.2 miles East of Herscher Road LOGGED BY W. Carter

SECTION 12-BR LOCATION SE 1/4, SEC. 32, TWP. 31N, RNG. 10E, 3rd PM,
Latitude , Longitude

COUNTY Kankakee DRILLING METHOD _____ HAMMER TYPE _____

STRUCT. NO. <u>046-0032 (Exist.)</u>	D E P T H	B L O W S	U C S Qu	M O I S T	Surface Water Elev. _____ ft
Station <u>965+84.5</u>					Stream Bed Elev. _____ ft
BORING NO. <u>4</u>	ft (ft)	(/6")	(tsf)	(%)	Groundwater Elev.: _____ ft
Station <u>966+09</u>					First Encounter _____ ft
Offset <u>33.0 ft Lt.</u>					Upon Completion _____ ft
Ground Surface Elev. <u>611.20</u>					After _____ Hrs. _____ ft

Stiff Dark Brown Silty Clay	610.00				
Very Stiff Mottled Clay	607.00				
Dense Yellow Sandy Silt	605.50				
Hard Gray Silty Till	599.50				
Very Stiff Gray Sandy Till	596.00	41	3.2		
			6.5		
Hard Gray Limestone	592.00	156			
End of Boring	-20				

SOIL BORING 046-0032.GPJ IL_DOT.GDT 9/4/20

The Unconfined Compressive Strength (UCS) Failure Mode is indicated by (B-Bulge, S-Shear, P-Penetrometer)
The SPT (N value) is the sum of the last two blow values in each sampling zone (AASHTO T206)

Pile Design Table for Abutments (2019) utilizing Boring #01 sta 967+18 16LT

Nominal Required Bearing (Kips)	Factored Resistance Available (Kips)	Estimated Pile Length (Ft.)	Nominal Required Bearing (Kips)	Factored Resistance Available (Kips)	Estimated Pile Length (Ft.)	Nominal Required Bearing (Kips)	Factored Resistance Available (Kips)	Estimated Pile Length (Ft.)			
			Steel HP 10 X 42			Steel HP 12 X 84					
						203	112	26	262	144	26
						288	158	27	425	234	27
						Steel HP 10 X 57			650	357	27
						211	116	26	Steel HP 14 X 73		
						323	178	27	267	147	25
						Steel HP 12 X 53			277	152	25
						243	134	26	287	158	26
						349	192	27	297	163	26
						Steel HP 12 X 63			441	243	27
						251	138	26	Steel HP 14 X 89		
						375	206	27	266	146	24
						Steel HP 12 X 74			276	152	25
						257	141	26	286	157	25
						402	221	27	296	163	26
						306	168	26			
						480	264	27			
						Steel HP 14 X 102					
						235	129	22			
						273	150	24			
						283	155	25			
						293	161	25			
						303	167	26			
						313	172	26			
						511	281	27			
						778	428	27			
						Steel HP 14 X 117					
						241	132	22			
						281	155	24			
						291	160	25			
						301	166	25			
						312	171	26			
						322	177	26			
						548	301	27			
						817	449	27			
						Precast 14"x 14"					
						209	115	14			
Steel HP 8 X 36											
236	130	27									



This SGR has been updated.
See memo dated 8/31/2020
for changes.

Abbreviated Structure Geotechnical Report

Original Report Date: 6/25/2020 Proposed SN: 046-0161 Route: FAP 41 (IL 17)
Revised Date: _____ Existing SN: 046-0032 Section: 12-BR
Geotechnical Engineer: Mark Jones of McCleary Engineering County: Kankakee
Structural Engineer: William Vegrzyn of V3 Companies Contract: 66970

Indicate the proposed structure type, substructure types, and foundation locations (attach plan and elevation drawing): The proposed structure SN046-0161 carries IL 17 over the east branch of Horse Creek. The structure is a single span bridge with integral abutments, no skew, with an out to out superstructure width of 38.83 ft. and a back to back abutment length of 103.0 ft. The estimated total factored loading at the abutments is 1920 kips. The abutments will be supported by steel piles set in limestone.

Discuss the existing boring data, existing plans foundation information, new subsurface exploration and need for any additional exploration to be provided with SGR Technical Memo (attach all data and subsurface profile plot): The existing structure SN 046-0032 is a three-span bridge on open abutments supported on piling. The piers are on spread footings.

Four (4) borings were available from August 1958, these borings all show a similar stratigraphy with Limestone beginning around elevation 595.0 ft. Boring 1 has a ground surface elevation of 615.80 ft and a depth of 25.8 ft. The upper 1.5 ft of the boring is Silty Clay, below the Silty Clay is a loose Clayey Silty Sand down to an elevation of 609.5 ft. From 609.5 ft. to 594.0 ft is a stiff to hard Sandy Clay Till. Boring 1 is terminated at 590.0 ft. in a 100+ blow count hard limey Clay.

Boring 2 has a ground surface elevation of 615.4 ft. and a depth of 24.4 ft. The first 8.9 ft. of the boring is a stiff Silty Sandy Clay. From 606.5 ft. to 595.2 ft. is alternating layers of hard Silty Clay Till and Sandy Clay Till. Boring 2 encountered broken Limestone at 595.2 ft. and is terminated at 591.0 ft. in Limestone.

Boring 3 has a ground surface elevation of 612.6 ft and a depth of 21.4 ft. The first 8.6 ft of the boring is a stiff to very stiff Silty Sandy Clay. From 604.0 ft. to 595.2 ft. is alternating layers of hard Silty Till and Sandy Clay Till. Boring 3 encountered gray Limestone at 595.2 ft and is terminated at 591.2 ft.

Boring 4 has a ground surface elevation of 611.2 ft and a depth of 19.2 ft. The upper 4.2 ft is a stiff to very stiff Silty Clay to Clay, below this layer is 1.5 ft of dense Sandy Silt. From 605.5 ft. to 596.0 ft. is a 6 ft. of hard Silty Till on top of 3.5 ft of very stiff Sandy Till. Boring 4 encountered hard gray Limestone at 596.0 ft and is terminated at 592.0 ft.

In August 2019 one additional boring, B-01, was taken ±84 ft. east of the proposed east abutment. Boring 01 (2019) has a ground surface elevation of 618.68 ft. and a depth of 33.5 ft. Soils were consistent with the 1958 borings above an elevation of ±594 to 596 ft. The 1958 borings reported no groundwater; the 2019 boring reported water at 605.7 ft., but dry upon completion. In Boring 01, under 7.5 ft. of Sandy Clay Loam Till fill and Silty Loam fill was stiff to hard Silty Clay, Silty Clay Loam, and Silty Clay Loam Till down to an elevation of 594.18 ft. The final 9.0 ft. reported in the boring, above an assumed Limestone surface at 585.18, is hard Gray Silt / Loam with carbonized Organics – very dense (borderline Shale). The final 9 ft. had blow counts above 34 and $Q_{us} > 4.5$ tsf.

Boring 1 (1958) is the closest to Boring 01 (2019) and reported 4 ft. of hard gray limey Clay above the end of boring at 590.0 ft. The other 3 1958 borings, further west, all reported broken Limestone or Limestone in the 4 ft. above the end of boring ±591 to 592 ft. There are no cores or pictures of the Limestone. The author feels the ± 6 to 7 foot difference in the top of assumed limestone in the 2019 boring and the 1958 end of boring elevations could partially be due to the different sampling methods used today. However due to the fact we do have 5 borings which indicate a limestone bedrock near the surface, the decision has been made to use 585.2 as the bedrock elevation for both abutments. Any variation in the elevation should be obvious when they drive the test pile.

Provide the location and maximum height of any new soil fill or magnitude of footing bearing pressure. Estimate the amount and time of the expected settlement. Indicate if further testing, analysis, and/or ground improvement/treatment is necessary: Any rise in the profile at the abutments is expected to be minimal. The existing embankment is over 60 years old, settlement should have already occurred. There is expected to be little or no settlement. When the BCR becomes available it will be reviewed to identify any existing settlement problems.

Identify any new cuts or fill slope angles and heights. Estimate the factor of safety against slope failure. Indicate if further testing, analysis or ground improvement/treatment is necessary: There are no cross sections this time, however with minimal grade change anticipated, fill slope angles will remain the same. The end slopes being only ±6 ft. tall and the very stiff to hard soils in the area will result in stable side slopes.

Indicate at each substructure, the 100-year and 200-year total scour depths in the Hydraulics report, the non-granular scour depth reduction, the proposed ground surface, and the recommended foundation design scour elevations: No scour was accounted for at the abutments per IDOT Policy. Spill through abutments shall be protected by riprap or slope wall in accordance to the Bridge Manual.

Event/Limit	Design Scour Elevations (ft.)		Item
	W. Abut	E. Abut.	
State			113
Q100	-	-	8
Q200	-	-	
Design	611.59	611.68	
Check	611.59	611.68	

Determining the seismic soil site class, the seismic performance zone, the 0.2 and 1.0 second design spectral accelerations and indicate if that the soils are liquefiable: This site has a seismic site class of "C", the seismic performance zone (SPZ)=1. The SDS= 0.128 g and an S_{D1} =0.073 g. Due to the S_{D1} being less than 0.15 g, a liquefaction analysis was not performed.

Confirm feasibility of the proposed foundation or wall type and provide design parameters. Attach a pile design table indicating feasible pile types, various nominal required bearings, factored resistances available and corresponding estimated lengths at locations where piles will be used. Provide factored bearing resistance and unit sliding resistance at various elevations and confirm no ground improvement/treatment is necessary where spread footings are proposed. Estimated top of rock elevations as well as preliminary factored unit side and tip resistance values shall be indicated when drilled shafts are proposed: Data from the four September 2019 Boring is more complete than the 1958 borings and is considered representative of the soils in the vicinity. Boring 01 was used to populate the data fields in the Estimated Pile Length spreadsheets.

Integral Abutment Feasibility (BBS 145) spreadsheets are also included. Information from both the 1958 and 2019 borings was used to populate the fields in the spreadsheet. Pre-cored shafts with a diameter of 24 inches, backfilled with bentonite, would allow for the required movement to use integral abutments at this location.

We recommend the use of H-piles. Due to the hard soils and shallow bedrock, we recommend coring to bedrock with the piles socketed in rock. One test pile is recommended at the west abutment. A table providing pile resistance and lengths for various recommended sizes is included in this report. This table was generated using no geotechnical losses associated with scour, liquefaction or consolidation. A full set of pile length spreadsheets for all the applicable sizes and wall thickness of metal shell piles are included in the appendix.

Assumptions used for the pile length analysis include:

- Bottom of West and East Abutment Elevations = 611.0 ft.
- The total factored loading for the abutments is 1920 kips.
- The pile cutoff allows for a 2 ft. embedment into the concrete for the abutments,
- No other geotechnical losses were accounted for in this analysis.
- Top of Limestone elevation = 585.18

Both Abutments, using Boring 01 (2019)			Both Abutments, using Boring 01 (2019)		
Nominal Required Bearing (kips)	Factored Resistance Available (kips)	Estimated Pile Length (Ft.)	Nominal Required Bearing (kips)	Factored Resistance Available (kips)	Estimated Pile Length (Ft.)
Steel HP 10 x 42			Steel HP 12 x 53		
172	95	24	207	114	24
285	157	26	346	190	26
335	184	28	418	230	28
Steel HP 12x 63			Steel HP 14 x 73		
214	118	24	253	139	24
371	204	26	437	240	26
497	273	28	578	318	28
Steel HP 14 x 89					
262	144	24			
476	262	26			
705	388	28			

Calculate the estimated water surface elevation and determine the need for cofferdams (type 1 or 2), and seal coat: The E.W.S.E. is 606.0 ft., no in stream work is anticipated during the construction of the abutments, therefore there is no need for a cofferdam.

Assess the need for sheeting or soil retention or temporary construction slope and provide recommendation for other construction concerns: At this time, we anticipate the structure to be built under staged construction conditions, therefore, Temporary Soil Retention will be required at the stage line. From the data Shown in the boring logs, driving sheet piling to the design embedment would not be possible: we recommend a Temporary Soil Retention System. The substructures shall be removed as per Section 501 of the 2016 IDOT Standard Specifications for Road And Bridge Construction.

Prepared by Mark E. Jones of McCleary Engineering
 MarkJ@McClearyEngineering.com



Mark E. Jones

Illinois Professional Engineer
 License No.062 043271 Exp. 11/2021

Benchmark: BM 111: Chiseled "X" on top of the NE wingwall of SN 046-0032; Elev. 619.12, Sta. 966+33.28, offset 17.89' Lt.

Existing Structure: SN 046-0032 was originally constructed in 1959 as S.B.I. Route 17, Section 12-BR at Station 965+84.5. The existing 3-span reinforced concrete slab superstructure is supported by open pile bent abutments on steel H-piles and tapered solid wall piers on spread footings. The outer spans are 29'-0" and the middle span is 36'-6" with no skew. The back-to-back of abutments measure 98'-0" and the out-to-out width is 36'-4". The existing structure will be removed and replaced utilizing staged construction.

No salvage.

DESIGN SPECIFICATIONS
2020 AASHTO LRFD Bridge Design Specifications, 9th Edition

LOADING HL-93
Allow 50#/sq. ft. for future wearing surface.

DESIGN STRESSES
FIELD UNITS

$f'_c = 3,500$ psi
 $f'_c = 4,000$ psi (Superstructure Concrete)
 $f_y = 60,000$ psi (Reinforcement)
PRECAST PRESTRESSED UNITS
 $f'_c = 8,500$ psi
 $f'_{ci} = 6,500$ psi
 $f_{pu} = 270,000$ psi (0.6" \odot Low Relaxation Strands)
 $f_{pbt} = 202,300$ psi (0.6" \odot Low Relaxation Strands)

SEISMIC DATA

Seismic Performance Zone (SPZ) = 1
Design Spectral Acceleration at 1.0 sec. (SD1) = 0.073
Design Spectral Acceleration at 0.2 sec. (SDS) = 0.128
Soil Site Class = C

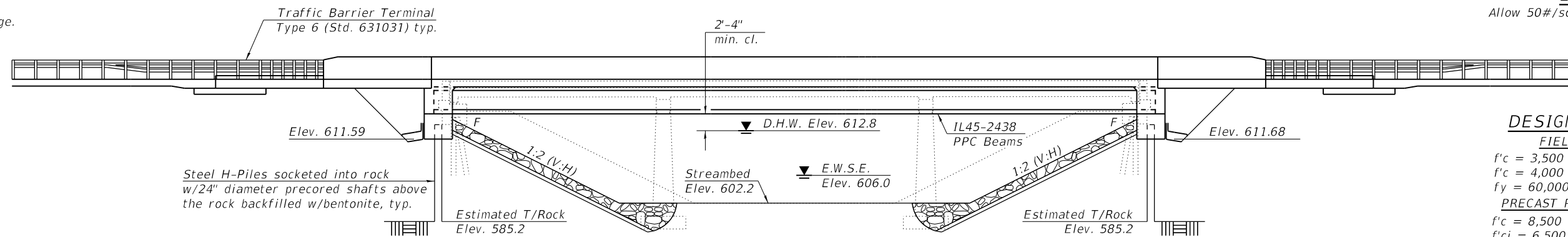

ELEVATION

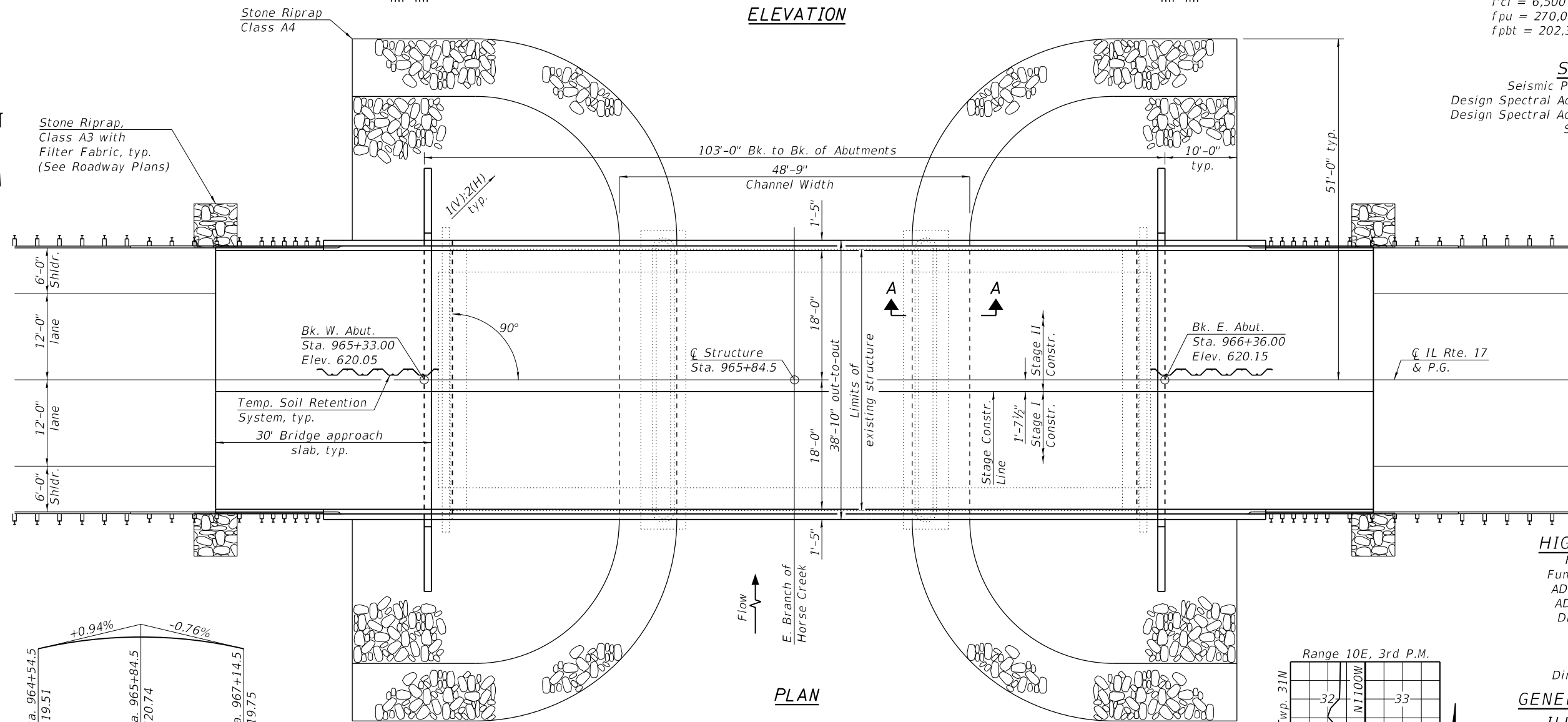

PLAN

Note: See sheet 2 of 2 for Section A-A.

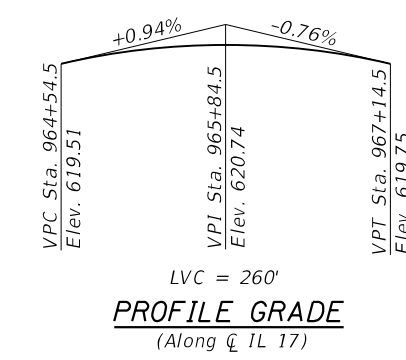

PROFILE GRADE
(Along ϕ IL 17)

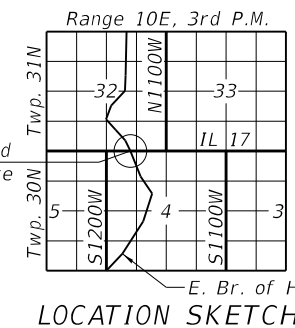

LOCATION SKETCH

HIGHWAY CLASSIFICATION

F.A.P. Rte. 41 - IL Rte. 17
Functional Class: Minor Arterial
ADT: 4250 (2015); 5538 (2043)
ADTT: 599 (2015); 781 (2043)
DHV: 468 (2015); 609 (2043)
Design Speed: 55 m.p.h.
Posted Speed: 55 m.p.h.
Two-Way Traffic
Directional Distribution: 50:50

GENERAL PLAN AND ELEVATION
ILLINOIS ROUTE 17 OVER
EAST BRANCH OF HORSE CREEK
F.A.P. RTE. 41 - SEC. (12)BR
KANKAKEE COUNTY
STATION 965+84.50
STRUCTURE NO. 046-0161

MODEL: V3
FILE NAME: V3 Companies
7325 Janes Avenue
Woodridge, IL 60517
630.724.9200 phone
630.724.9202 fax
www.v3co.com

USER NAME =	DESIGNED - B. Vegrzyn	REVISED -
PLOT SCALE =	CHECKED - D. Greifzu	REVISED -
PLOT DATE =	DRAWN - B. Vegrzyn	REVISED -
	CHECKED - D. Greifzu	REVISED -

STATE OF ILLINOIS
DEPARTMENT OF TRANSPORTATION

F.A.P. RTE.	SECTION	COUNTY	TOTAL SHEETS	SHEET NO.
41	(12)BR	Kankakee		
CONTRACT NO. 66970				
ILLINOIS FED. AID PROJECT				

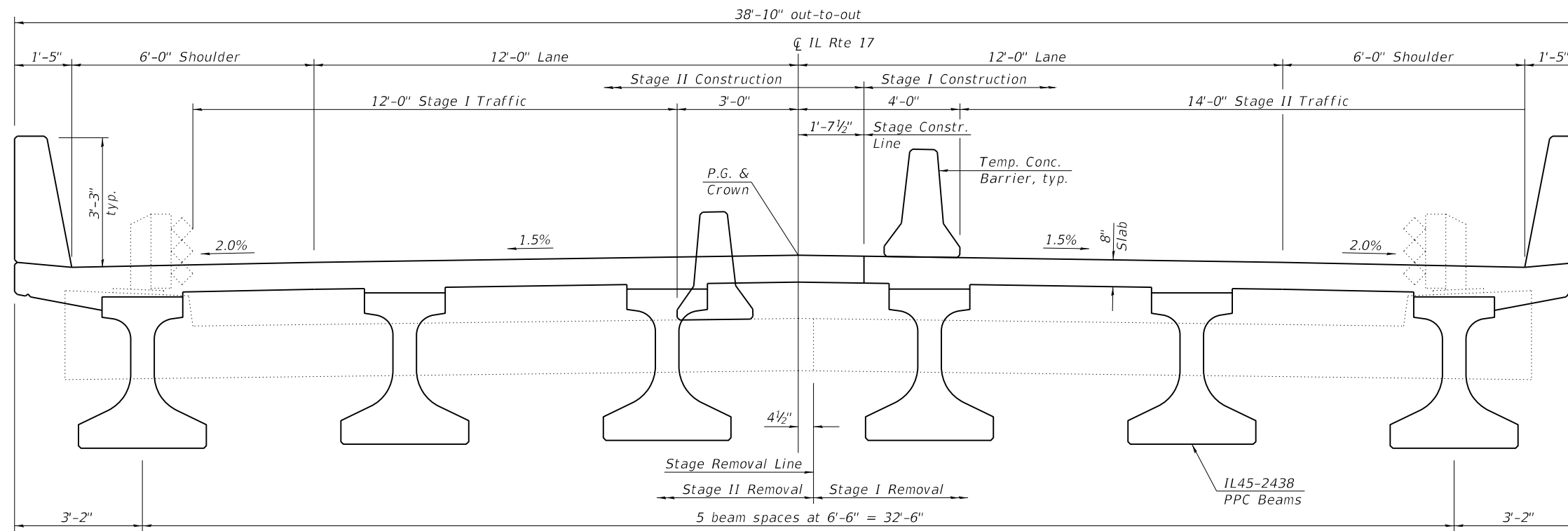

CROSS SECTION
(Looking East)

WATERWAY INFORMATION

Existing Overtopping Elev.=617.56 @ Sta. 975+00
 Drainage Area=27.1 sq.mi. Proposed Overtopping Elev.=617.56 @ Sta. 975+00

Flood	Freq. Yr.	Q C.F.S.	Opening Ft ²		Nat. H.W.E.	Head - Ft.		Headwater El.	
			Exist.	Prop.		Exist.	Prop.	Exist.	Prop.
10	10	1350	434	683	612.1	0.2	0.1	612.3	612.3
Design	50	2040	475	739	612.8	0.4	0.2	613.1	613.0
Base	100	2350	494	767	613.1	0.5	0.2	613.5	613.3
Scour Check	200	2668	512	792	613.3	0.5	0.3	613.9	613.6
Max. Calc.	500	3100	535	823	613.7	0.7	0.4	614.4	614.0

10 Year velocity through existing structure = 3.1 ft./sec.
 10 Year velocity through proposed structure = 2.0 ft./sec.

DESIGN SCOUR ELEVATION TABLE

Event / Limit	Design Scour Elevations (ft.)		
	State	W. Abut.	E. Abut. Item 113
Q100	611.59	611.68	8
Q200	611.59	611.68	
Design	611.59	611.68	
Check	611.59	611.68	

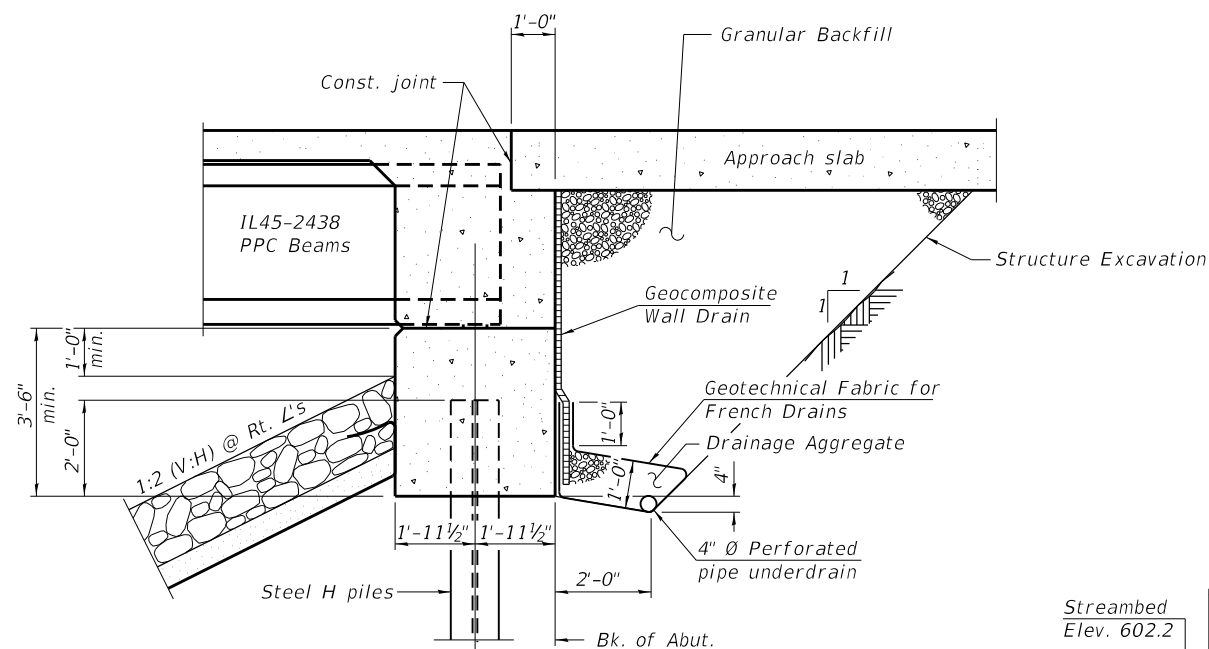

SECTION THRU INTEGRAL ABUTMENT

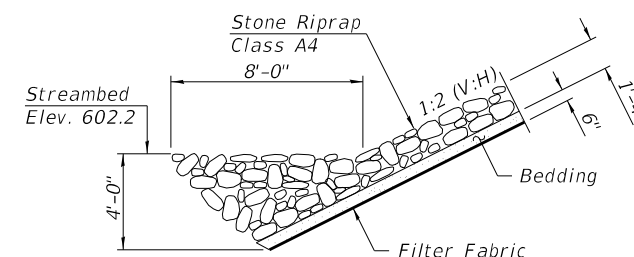

SECTION A-A

DETAILS
ILLINOIS ROUTE 17 OVER
EAST BRANCH OF HORSE CREEK
F.A.P. RTE. 41 - SEC. (12)BR
KANKAKEE COUNTY
STATION 965+84.50
STRUCTURE NO. 046-0161



Illinois Department of Transportation

Division of Highways
Illinois Department of Transportation

This sheet is superseded by the revised boring logs. See memo dated 8/31/2020 for more information

SOIL BORING LOG

Date 8/1/58

ROUTE SBI-17 (IL 17) DESCRIPTION IL 17 over East Branch of Horse Creek, 0.2 miles East of Herscher Road LOGGED BY W. Carter

SECTION 12-BR LOCATION SE 1/4, SEC. 32, TWP. 31N, RNG. 10E, 3rd PM, Latitude , Longitude

COUNTY Kankakee DRILLING METHOD _____ HAMMER TYPE _____

STRUCT. NO. <u>046-0032 (Exist.)</u>	D E P T H	B L O W S	U C S Qu	M O I S T	Surface Water Elev. _____ ft
Station <u>965+84.5</u>					Stream Bed Elev. _____ ft
BORING NO. <u>4</u>	ft (ft)	(/6")	(tsf)	(%)	Groundwater Elev.: _____ ft
Station <u>966+09</u>					First Encounter _____ ft
Offset <u>33.0 ft Lt.</u>					Upon Completion _____ ft
Ground Surface Elev. <u>611.20</u>					After _____ Hrs. _____ ft

Stiff Dark Brown Silty Clay	610.00				
Very Stiff Mottled Clay	607.00				
Dense Yellow Sandy Silt	605.50	-5			
Hard Gray Silty Till	599.50				
Very Stiff Gray Sandy Till	596.00	-15	41	3.2	6.5
Hard Gray Limestone	592.00		156		
End of Boring		-20			

SOIL BORING 046-0032.GPJ IL_DOT.GDT 10/31/19

The Unconfined Compressive Strength (UCS) Failure Mode is indicated by (B-Bulge, S-Shear, P-Penetrometer)
The SPT (N value) is the sum of the last two blow values in each sampling zone (AASHTO T206)

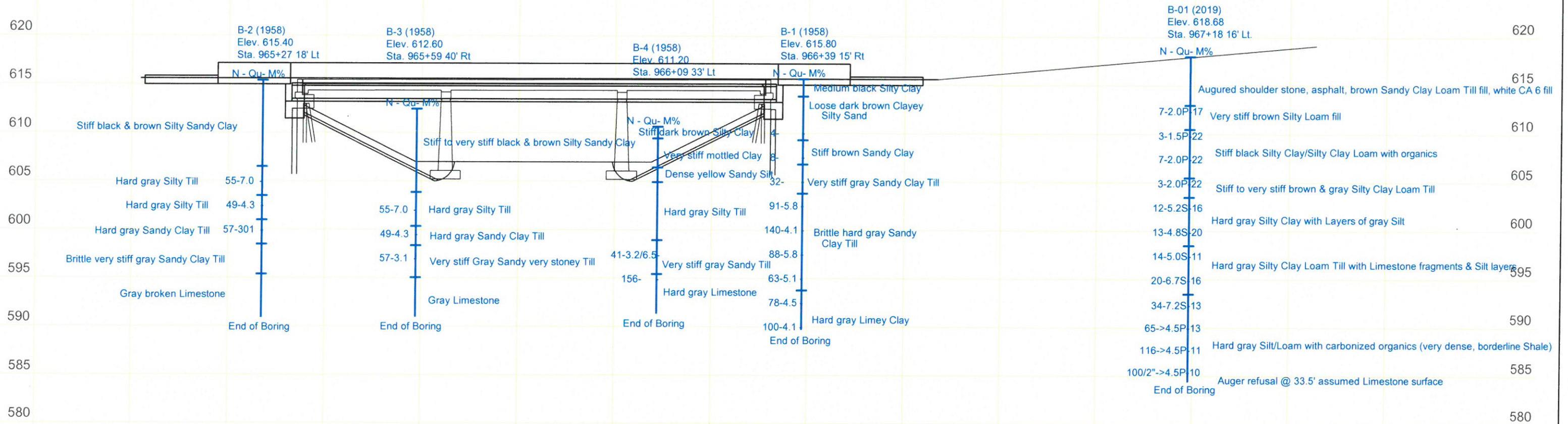

965+00

965+50

966+00

966+50

967+00

967+50



Designed by:	Date:
Drawn by: MLL	Date: 4-13-20
Checked by:	Date:

Illinois Rte. 17 over East Branch of Horse Creek		
Scale = NA	Sheet 1 of 1	Sta. _____ to Sta. _____

Route	Section	County
SBI-17	12-BR	Kankakee
Bridge number: 046-0032		

JSON Raw Data Headers

Save Copy Collapse All Expand All Filter JSON

request:

```
date: "2020-06-06T19:56:28.935Z"
referenceDocument: "AASHTO-2009"
status: "success"
url: "https://earthquake.usgs.gov/ws/designmaps/aashto-2009.json?Latitude=41.117218&Longitude=-88.093843&siteClass=C&title=SN 046-0032 IL 17 over the E. branch of Horse Creek"
```

parameters:

```
latitude: 41.117218
longitude: -88.093843
siteClass: "C"
title: "SN 046-0032 IL 17 over the E. branch of Horse Creek"
```

response:

data:

```
pga: 0.048
fpga: 1.2
as: 0.057
ss: 0.107
fa: 1.2
sds: 0.128
s1: 0.043
fv: 1.7
sd1: 0.073
sdc: "A"
ts: 0.573
t0: 0.115
```

twoPeriodDesignSpectrum:

```
0:
  0: 0
  1: 0.057
1:
  0: 0.025
  1: 0.073
2:
  0: 0.05
  1: 0.088
3:
  0: 0.1
  1: 0.119
4:
  0: 0.115
  1: 0.128
5:
  0: 0.15
  1: 0.128
6:
```



This sheet is superseded by revised calculations.
See memo dated 8/31/2020 for more information

SEISMIC SITE CLASS DETERMINATION

PROJECT TITLE=====**SN 046-0032**

Substructure 1

Base of Substruct. Elev. (or ground surf for bents) **611** ft.
 Pile or Shaft Dia. **12** inches
 Boring Number **B-01 (2019)**
 Top of Boring Elev. **618.68** ft.
 Approximate Fixity Elev. **605** ft.

Individual Site Class Definition:

N (bar): **53** (Blows/ft.) Soil Site Class C
 N_{ch} (bar): **NA** (Blows/ft.) NA
 s_u (bar): **4.51** (ksf) Soil Site Class C <----Controls

Seismic Soil Column Depth (ft)	Bot. Of Sample Elevation (ft)	Sample Thick. (ft)	Sample		Layer Description Boundary
			N (tsf)	Qu (tsf)	
	616.2	2.50	8	1.00	
	613.7	2.50	8	1.00	B
	611.2	2.50	7	2.00	B
	608.7	2.50	3	1.50	B
	606.2	2.50	7	2.00	B
0.8	604.2	2.00	3	2.00	B
3.3	601.7	2.50	12	5.20	
5.8	599.2	2.50	13	4.80	B
8.3	596.7	2.50	14	5.00	
10.8	594.2	2.50	20	6.70	B
13.3	591.7	2.50	34	7.20	
15.8	589.2	2.50	65	4.50	
18.3	586.7	2.50	116	4.50	
19.8	585.2	1.50	600	4.50	R
100.0	505.0	80.20	600	4.50	

Substructure 2

Base of Substruct. Elev. (or ground surf for bents) **611** ft.
 Pile or Shaft Dia. **12** inches
 Boring Number **B-1 (1958)**
 Top of Boring Elev. **615.8** ft.
 Approximate Fixity Elev. **605** ft.

Individual Site Class Definition:

N (bar): **96** (Blows/ft.) Soil Site Class C <----Controls
 N_{ch} (bar): **NA** (Blows/ft.) NA
 s_u (bar): **4.17** (ksf) Soil Site Class C

Seismic Soil Column Depth (ft)	Bot. Of Sample Elevation (ft)	Sample Thick. (ft)	Sample		Layer Description Boundary
			N (tsf)	Qu (tsf)	
	614.0	1.80	8	1.00	B
	612.0	2.00	8		
	609.5	2.50	4		B
	607.0	2.50	8		B
1.0	604.0	3.00	32		B
3.5	601.5	2.50	91	5.80	
6.0	599.0	2.50	140	4.10	
8.5	596.5	2.50	88	5.60	
11.0	594.0	2.50	63	5.10	B
13.0	592.0	2.00	75	4.50	
15.0	590.0	2.00	100	4.10	B
100.0	505.0	85.00	100	4.10	R

Substructure 3

Base of Substruct. Elev. (or ground surf for bents) **611** ft.
 Pile or Shaft Dia. **12** inches
 Boring Number **B-2 (1958)**
 Top of Boring Elev. **615.4** ft.
 Approximate Fixity Elev. **605** ft.

Individual Site Class Definition:

N (bar): **62** (Blows/ft.) Soil Site Class C
 N_{ch} (bar): **NA** (Blows/ft.) NA
 s_u (bar): **4.38** (ksf) Soil Site Class C <----Controls

Seismic Soil Column Depth (ft)	Bot. Of Sample Elevation (ft)	Sample Thick. (ft)	Sample		Layer Description Boundary
			N (tsf)	Qu (tsf)	
	613.5	1.90	8	1.00	
	611.5	2.00	8	1.00	
	609.0	2.50	10	1.60	
	606.5	2.50	6	1.40	B
1.5	603.5	3.00	14	4.10	B
4.0	601.0	2.50	65	4.70	B
6.5	598.5	2.50	67	4.40	B
9.8	595.2	3.30	64	3.90	B
12.0	593.0	2.20	65	4.40	
14.0	591.0	2.00	65	4.40	R
100.0	505.0	86.00	65	4.40	

Substructure 4

Base of Substruct. Elev. (or ground surf for bents) **611** ft.
 Pile or Shaft Dia. **12** inches
 Boring Number **B-3 (1958)**
 Top of Boring Elev. **612.6** ft.
 Approximate Fixity Elev. **605** ft.

Individual Site Class Definition:

N (bar): **60** (Blows/ft.) Soil Site Class C
 N_{ch} (bar): **NA** (Blows/ft.) NA
 s_u (bar): **3.89** (ksf) Soil Site Class C <----Controls

Seismic Soil Column Depth (ft)	Bot. Of Sample Elevation (ft)	Sample Thick. (ft)	Sample		Layer Description Boundary
			N (tsf)	Qu (tsf)	
	610.0	2.60	8	1.00	
	607.0	3.00	8	1.00	
1.0	604.0	3.00	8	1.00	B
3.0	602.0	2.00	55	7.00	
5.0	600.0	2.00	55	7.00	B
7.0	598.0	2.00	49	4.30	B
10.3	594.7	3.30	57	3.10	B
12.3	592.7	2.00	65	4.40	
14.3	590.7	2.00	65	4.40	R
100.0	505.0	85.70	65	4.40	

Global Site Class Definition: Substructures 1 through 5

N (bar): **71** (Blows/ft.) Soil Site Class C
 N_{ch} (bar): **(Blows/ft.)** NA, H < 0.1'H (Total)
 s_u (bar): **4.28** (ksf) Soil Site Class C <----Controls



This sheet is superseded by revised calculations. See memo dated 8/31/2020 for more information

INTEGRAL ABUTMENT FEASIBILITY ANALYSIS
Modified 10/30/17

GENERAL DATA

STRUCTURE NUMBER=====046 0032 using 2019 boring data
 STRUCTURE TYPE =====SIMPLE-SPAN
 STRUCTURE SKEW=====0 DEGREES
 SUPER. DATA IN REFERENCE TO SUB. DATA ===== ABUT 2
 TOTAL STRUCTURE LENGTH===== 103.00 FT

SUPERSTRUCTURE DATA (END OR MAIN SPAN)	
BEAM TYPE	CONCRETE BEAM
CONCRETE BEAM	IL45-2438
BEAM F'C	8.5 KSI
BEAM SPACING PERP. TO CL	7.00 FT
SLAB THICKNESS	8.00 IN
SLAB F'C	4.00 KSI

SUPERSTRUCTURE DATA (ADJACENT SPAN)	
BEAM TYPE	
CONCRETE BEAM	
BEAM F'C	
BEAM SPACING PERP. TO CL	
SLAB THICKNESS	
SLAB F'C	

ABUTMENT #1 DATA	
ABUTMENT NAME	East
ABUTMENT REFERENCE BORING	Boring 01 (2019)
BOTTOM OF ABUTMENT ELEVATION	611 FT
ESTIMATED NUMBER OF PILES AT ABUT.	6
PILE SPACING PERP. TO CL	7 FT

ABUTMENT #2 DATA	
ABUTMENT NAME	West
ABUTMENT REFERENCE BORING	Boring 2(1958)
BOTTOM OF ABUTMENT ELEVATION	611 FT
ESTIMATED NUMBER OF PILES AT ABUT.	6
PILE SPACING PERP. TO CL	7 FT

SOIL DATA FOR 10 FT BENEATH BOTTOM OF ABUTMENT #1				
BOT. OF LAYER ELEV. (FT)	LAYER THICKNESS (FT)	UNCONFINED COMPRESSIVE STRENGTH (TSF)	N S.P.T. VALUE (BLOWS/12 IN.)	Qu EQUIV. FOR N VALUE (TSF)
606.18	4.82	1.8		
604.18	2.00	2.0		
601.00	3.18	5.2		

SOIL DATA FOR 10 FT BENEATH BOTTOM OF ABUTMENT #2				
BOT. OF LAYER ELEV. (FT)	LAYER THICKNESS (FT)	UNCONFINED COMPRESSIVE STRENGTH (TSF)	N S.P.T. VALUE (BLOWS/12 IN.)	Qu EQUIV. FOR N VALUE (TSF)
606.50	4.50	1.5		
603.50	3.00	4.1		
601.00	2.50	4.7		

10.00 FT = TOTAL DEPTH ENTERED

10.00 FT = TOTAL DEPTH ENTERED

WEIGHTED AVERAGE Qu FOR ABUTMENT #1===== 2.92 TSF

WEIGHTED AVERAGE Qu FOR ABUTMENT #2===== 3.08 TSF

PILE STIFFNESS MODIFIER FOR ABUTMENT #1
 = 1/(1.45-[0.3*2.92])===== 1.74

PILE STIFFNESS MODIFIER FOR ABUTMENT #2
 = 1/(1.45-[0.3*3.08])===== 1.90

WEIGHTED AVG. Qu > 3.0 TSF WITH TRIB. LENGTH > 20%, INTEGRAL ABUTMENT STRUCTURE NOT ALLOWED

DISTANCE TO CENTROID OF STIFFNESS FROM ABUTMENT #1 = [1.74*6*0+1.9*6*103]/[1.74*6+1.9*6]===== 53.73 FT

DISTANCE TO CENTROID OF STIFFNESS FROM ABUTMENT #2 = [1.9*6*0+1.74*6*103]/[1.9*6+1.74*6]===== 49.27 FT

ABUT 2 (West) - EXPANSION LENGTH LIMIT CHART - 0 DEG. SKEW

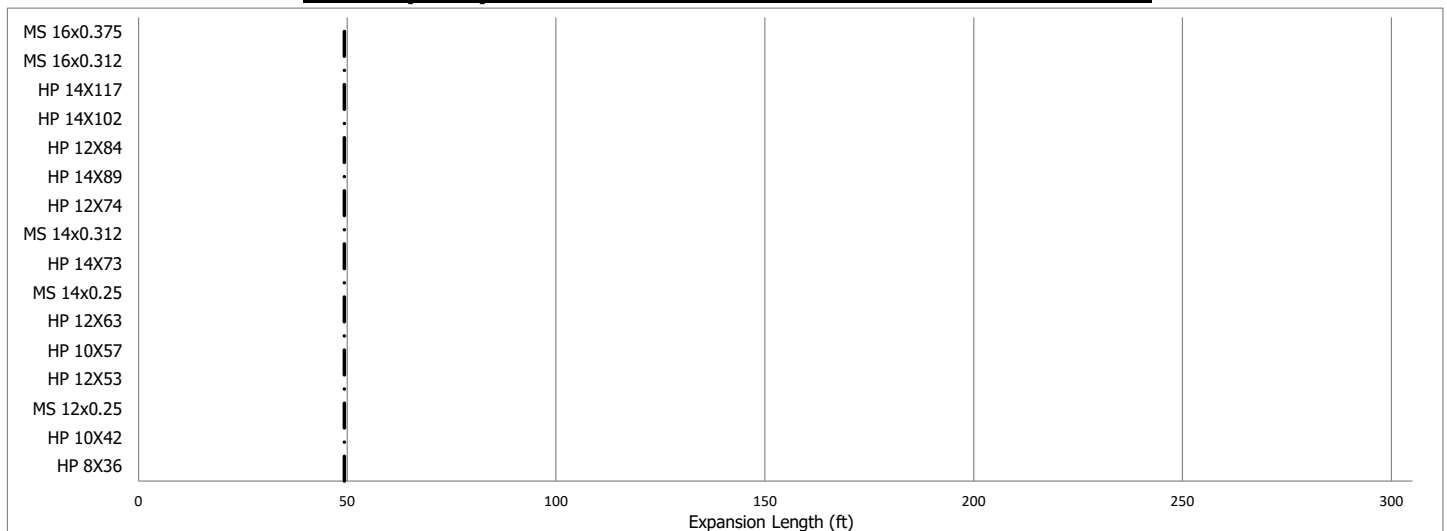

--- = Estimated expansion length for the indicated abutment. Piles with an expansion length greater than this are suitable for consideration (Note: The same size pile should be used at both abutments.)

Pile Design Table for Abutments using 2019 boring utilizing Boring #01 sta 967+18 16 Lt

Nominal Required Bearing (Kips)	Factored Resistance Available (Kips)	Estimated Pile Length (Ft.)	Nominal Required Bearing (Kips)	Factored Resistance Available (Kips)	Estimated Pile Length (Ft.)	Nominal Required Bearing (Kips)	Factored Resistance Available (Kips)	Estimated Pile Length (Ft.)
			Steel HP 10 X 42			Steel HP 12 X 84		
			172	95	24	225	124	24
			285	157	26	422	232	26
			335	184	28	664	365	28
			Steel HP 10 X 57			Steel HP 14 X 73		
			180	99	24	253	139	24
			320	176	26	437	240	26
			454	250	28	578	318	28
			Steel HP 12 X 53			Steel HP 14 X 89		
			207	114	24	262	144	24
			346	190	26	476	262	26
			418	230	28	705	388	28
			Steel HP 12 X 63			Steel HP 14 X 102		
214	118	24	268	148	24			
371	204	26	507	279	26			
497	273	28	810	445	28			
Steel HP 12 X 74			Steel HP 14 X 117					
220	121	24	237	130	21			
399	219	26	277	152	24			
589	324	28	544	299	26			
			929	511	28			
Steel HP 8 X 36								
233	128	26						

This sheet is superseded by revised calculations. See memo dated 8/31/2020 for more information

SUBSTRUCTURE===== Abutments using 2019 boring
 REFERENCE BORING ===== 01 sta 967+18 16 Lt
 LRFD or ASD or SEISMIC ===== LRFD
 PILE CUTOFF ELEV. ===== 613.00 ft
 GROUND SURFACE ELEV. AGAINST PILE DURING DRIVING = 611.00 ft
 GEOTECHNICAL LOSS TYPE (None, Scour, Liquef., DD) ===== None
 BOTTOM ELEV. OF SCOUR, LIQUEF., or DD ===== None ft
 TOP ELEV. OF LIQUEF. (so layers above apply DD) ===== None ft

MAX. REQUIRED BEARING & RESISTANCE for Selected Pile, Soil Profile, & Losses

Maximum Nominal Req'd Bearing of Pile	Maximum Nominal Req'd Bearing of Boring	Maximum Factored Resistance Available in Boring	Maximum Pile Driveable Length in Boring
335 KIPS	335 KIPS	184 KIPS	28 FT.

This sheet is superseded by revised calculations. See memo dated 8/31/2020 for more information

TOTAL FACTORED SUBSTRUCTURE LOAD ===== 1920 kips
 TOTAL LENGTH OF SUBSTRUCTURE (along skew)===== 38.83 ft
 NUMBER OF ROWS OF PILES PER SUBSTRUCTURE ===== 1
 Approx. Factored Loading Applied per pile at 8 ft. Cts ===== 395.57 KIPS
 Approx. Factored Loading Applied per pile at 3 ft. Cts ===== 148.34 KIPS

PILE TYPE AND SIZE ===== Steel HP 10 X 42
 Plugged Pile Perimeter===== 3.300 FT. Unplugged Pile Perimeter===== 4.858 FT.
 Plugged Pile End Bearing Area===== 0.680 SQFT. Unplugged Pile End Bearing Area===== 0.086 SQFT.

BOT. OF LAYER ELEV. (FT.)	LAYER THICK. (FT.)	UNCONF. COMPR. STRENGTH (TSF.)	S.P.T. N VALUE (BLOWS)	GRANULAR OR ROCK LAYER DESCRIPTION	NOMINAL PLUGGED			NOMINAL UNPLUG'D			NOMINAL REQ'D BEARING (KIPS)	FACTORED GEOTECH. LOSS FROM SCOUR or DD (KIPS)	FACTORED GEOTECH. LOSS LOAD FROM DD (KIPS)	FACTORED RESISTANCE AVAILABLE (KIPS)	ESTIMATED PILE LENGTH (FT.)
					SIDE RESIST. (KIPS)	END BRG. RESIST. (KIPS)	TOTAL RESIST. (KIPS)	SIDE RESIST. (KIPS)	END BRG. RESIST. (KIPS)	TOTAL RESIST. (KIPS)					
608.70	2.30	1.50	3		7.3		26.4	10.7		13.2	13	0	0	7	4
606.20	2.50	2.00	7		9.6	19.1	36.0	14.1	2.4	27.3	27	0	0	15	7
604.20	2.00	2.00	3		7.7	19.1	74.2	11.3	2.4	42.5	42	0	0	23	9
601.70	2.50	5.20	12		17.1	49.6	87.5	25.2	6.3	67.2	67	0	0	37	11
599.20	2.50	4.80	13		17.1	45.8	106.6	25.2	5.8	92.7	93	0	0	51	14
596.70	2.50	5.00	14		17.1	47.7	139.9	25.2	6.0	120.0	120	0	0	66	16
594.20	2.50	6.70	20		17.1	63.9	136.4	25.2	8.1	142.7	136	0	0	75	19
591.70	2.50		34	Hard Till	3.1	43.2	178.9	4.5	5.5	152.2	152	0	0	84	21
589.20	2.50		65	Hard Till	8.1	82.6	251.8	11.9	10.5	172.3	172	0	0	95	24
586.70	2.50		116	Hard Till	23.6	147.5	890.8	34.8	18.7	285.0	285	0	0	157	26
585.20	1.50		600	Hard Till	374.1	762.8	671.6	550.8	96.5	760.7	672	0	0	369	28
584.20	1.00			Limestone	82.2	169.5	753.9	121.0	21.5	881.8	754	0	0	415	28.8
583.20	1.00			Limestone	82.2	169.5	836.1	121.0	21.5	1002.8	836	0	0	460	29.8
582.20	1.00			Limestone	82.2	169.5	918.3	121.0	21.5	1123.8	918	0	0	505	30.8
581.20	1.00			Limestone	82.2	169.5	1000.5	121.0	21.5	1244.9	1001	0	0	550	31.8
580.20	1.00			Limestone	82.2	169.5	1082.7	121.0	21.5	1365.9	1083	0	0	596	32.8
579.20	1.00			Limestone	82.2	169.5	1164.9	121.0	21.5	1487.0	1165	0	0	641	33.8
578.20	1.00			Limestone	82.2	169.5	1247.2	121.0	21.5	1608.0	1247	0	0	686	34.8
577.20	1.00			Limestone	82.2	169.5	1329.4	121.0	21.5	1729.0	1329	0	0	731	35.8
576.20	1.00			Limestone	82.2	169.5	1411.6	121.0	21.5	1850.1	1412	0	0	776	36.8
575.20	1.00			Limestone	82.2	169.5	1493.8	121.0	21.5	1971.1	1494	0	0	822	37.8
574.20	1.00			Limestone		169.5			21.5						

SUBSTRUCTURE===== Abutments using 2019 boring
 REFERENCE BORING ===== 01 sta 967+18 16 Lt
 LRFD or ASD or SEISMIC ===== LRFD
 PILE CUTOFF ELEV. ===== 613.00 ft
 GROUND SURFACE ELEV. AGAINST PILE DURING DRIVING = 611.00 ft
 GEOTECHNICAL LOSS TYPE (None, Scour, Liquef., DD) ===== None
 BOTTOM ELEV. OF SCOUR, LIQUEF., or DD ===== None ft
 TOP ELEV. OF LIQUEF. (so layers above apply DD) ===== None ft

MAX. REQUIRED BEARING & RESISTANCE for Selected Pile, Soil Profile, & Losses

Maximum Nominal Req'd Bearing of Pile	Maximum Nominal Req'd Bearing of Boring	Maximum Factored Resistance Available in Boring	Maximum Pile Driveable Length in Boring
418 KIPS	418 KIPS	230 KIPS	28 FT.

This sheet is superseded by revised calculations. See memo dated 8/31/2020 for more information

TOTAL FACTORED SUBSTRUCTURE LOAD ===== 1920 kips
 TOTAL LENGTH OF SUBSTRUCTURE (along skew)===== 38.83 ft
 NUMBER OF ROWS OF PILES PER SUBSTRUCTURE ===== 1
 Approx. Factored Loading Applied per pile at 8 ft. Cts ===== 395.57 KIPS
 Approx. Factored Loading Applied per pile at 3 ft. Cts ===== 148.34 KIPS

PILE TYPE AND SIZE ===== Steel HP 12 X 53
 Plugged Pile Perimeter===== 3.967 FT. Unplugged Pile Perimeter===== 5.800 FT.
 Plugged Pile End Bearing Area===== 0.983 SQFT. Unplugged Pile End Bearing Area===== 0.108 SQFT.

BOT. OF LAYER ELEV. (FT.)	LAYER THICK. (FT.)	UNCONF. COMPR. STRENGTH (TSF.)	S.P.T. N VALUE (BLOWS)	GRANULAR OR ROCK LAYER DESCRIPTION	NOMINAL PLUGGED			NOMINAL UNPLUG'D			NOMINAL REQ'D BEARING (KIPS)	FACTORED GEOTECH. LOSS FROM SCOUR or DD (KIPS)	FACTORED GEOTECH. LOSS LOAD FROM DD (KIPS)	FACTORED RESISTANCE AVAILABLE (KIPS)	ESTIMATED PILE LENGTH (FT.)
					SIDE RESIST. (KIPS)	END BRG. RESIST. (KIPS)	TOTAL RESIST. (KIPS)	SIDE RESIST. (KIPS)	END BRG. RESIST. (KIPS)	TOTAL RESIST. (KIPS)					
608.70	2.30	1.50	3		8.8		36.3	12.8		15.8	16	0	0	9	4
606.20	2.50	2.00	7		11.5	27.6	47.9	16.9	3.0	32.7	33	0	0	18	7
604.20	2.00	2.00	3		9.2	27.6	101.2	13.5	3.0	51.1	51	0	0	28	9
601.70	2.50	5.20	12		20.6	71.7	116.3	30.1	7.8	80.6	81	0	0	44	11
599.20	2.50	4.80	13		20.6	66.1	139.7	30.1	7.2	111.0	111	0	0	61	14
596.70	2.50	5.00	14		20.6	68.9	183.7	30.1	7.5	143.7	144	0	0	79	16
594.20	2.50	6.70	20		20.6	92.3	174.5	30.1	10.1	170.6	171	0	0	94	19
591.70	2.50		34	Hard Till	3.7	62.5	235.1	5.4	6.8	182.3	182	0	0	100	21
589.20	2.50		65	Hard Till	9.7	119.4	338.6	14.2	13.1	206.7	207	0	0	114	24
586.70	2.50		116	Hard Till	28.4	213.1	1256.3	41.5	23.3	345.6	346	0	0	190	26
585.20	1.50		600	Hard Till	449.7	1102.5	848.6	657.6	120.6	909.4	849	0	0	467	28
584.20	1.00			Limestone	98.8	245.0	947.4	144.5	26.8	1053.9	947	0	0	521	28.8
583.20	1.00			Limestone	98.8	245.0	1046.2	144.5	26.8	1198.4	1046	0	0	575	29.8
582.20	1.00			Limestone	98.8	245.0	1145.1	144.5	26.8	1342.9	1145	0	0	630	30.8
581.20	1.00			Limestone	98.8	245.0	1243.9	144.5	26.8	1487.4	1244	0	0	684	31.8
580.20	1.00			Limestone	98.8	245.0	1342.7	144.5	26.8	1631.9	1343	0	0	738	32.8
579.20	1.00			Limestone	98.8	245.0	1441.5	144.5	26.8	1776.4	1442	0	0	793	33.8
578.20	1.00			Limestone	98.8	245.0	1540.4	144.5	26.8	1920.9	1540	0	0	847	34.8
577.20	1.00			Limestone	98.8	245.0	1639.2	144.5	26.8	2065.4	1639	0	0	902	35.8
576.20	1.00			Limestone	98.8	245.0	1738.0	144.5	26.8	2209.9	1738	0	0	956	36.8
575.20	1.00			Limestone	98.8	245.0	1836.8	144.5	26.8	2354.4	1837	0	0	1010	37.8
574.20	1.00			Limestone		245.0			26.8			0	0		

SUBSTRUCTURE=====Abutments using 2019 boring
 REFERENCE BORING ===== 01 sta 967+18 16 Lt
 LRFD or ASD or SEISMIC ===== LRFD
 PILE CUTOFF ELEV. ===== 613.00 ft
 GROUND SURFACE ELEV. AGAINST PILE DURING DRIVING = 611.00 ft
 GEOTECHNICAL LOSS TYPE (None, Scour, Liquef., DD) ===== None
 BOTTOM ELEV. OF SCOUR, LIQUEF., or DD ===== None ft
 TOP ELEV. OF LIQUEF. (so layers above apply DD) ===== None ft

MAX. REQUIRED BEARING & RESISTANCE for Selected Pile, Soil Profile, & Losses

Maximum Nominal Req'd Bearing of Pile	Maximum Nominal Req'd Bearing of Boring	Maximum Factored Resistance Available in Boring	Maximum Pile Driveable Length in Boring
497 KIPS	497 KIPS	273 KIPS	28 FT.

This sheet is superseded by
revised calculations.
See memo dated 8/31/2020
for more information

TOTAL FACTORED SUBSTRUCTURE LOAD ===== 1920 kips
 TOTAL LENGTH OF SUBSTRUCTURE (along skew)===== 38.83 ft
 NUMBER OF ROWS OF PILES PER SUBSTRUCTURE ===== 1
 Approx. Factored Loading Applied per pile at 8 ft. Cts ===== 395.57 KIPS
 Approx. Factored Loading Applied per pile at 3 ft. Cts ===== 148.34 KIPS

PILE TYPE AND SIZE ===== Steel HP 12 X 63

Plugged Pile Perimeter===== 4.000 FT. Unplugged Pile Perimeter===== 5.883 FT.
 Plugged Pile End Bearing Area===== 1.000 SQFT. Unplugged Pile End Bearing Area===== 0.128 SQFT.

BOT. OF LAYER ELEV. (FT.)	LAYER THICK. (FT.)	UNCONF. COMPR. STRENGTH (TSF.)	S.P.T. N VALUE (BLOWS)	GRANULAR OR ROCK LAYER DESCRIPTION	NOMINAL PLUGGED			NOMINAL UNPLUG'D			NOMINAL REQ'D BEARING (KIPS)	FACTORED GEOTECH. LOSS FROM SCOUR or DD (KIPS)	FACTORED GEOTECH. LOSS LOAD FROM DD (KIPS)	FACTORED RESISTANCE AVAILABLE (KIPS)	ESTIMATED PILE LENGTH (FT.)
					SIDE RESIST. (KIPS)	END BRG. RESIST. (KIPS)	TOTAL RESIST. (KIPS)	SIDE RESIST. (KIPS)	END BRG. RESIST. (KIPS)	TOTAL RESIST. (KIPS)					
608.70	2.30	1.50	3		8.8		36.9	13.0		16.6	17	0	0	9	4
606.20	2.50	2.00	7		11.6	28.0	48.5	17.1	3.6	33.7	34	0	0	19	7
604.20	2.00	2.00	3		9.3	28.0	102.7	13.7	3.6	53.1	53	0	0	29	9
601.70	2.50	5.20	12		20.8	72.9	117.9	30.6	9.3	83.0	83	0	0	46	11
599.20	2.50	4.80	13		20.8	67.3	141.4	30.6	8.6	113.9	114	0	0	63	14
596.70	2.50	5.00	14		20.8	70.1	186.1	30.6	9.0	147.6	148	0	0	81	16
594.20	2.50	6.70	20		20.8	93.9	176.5	30.6	12.0	174.3	174	0	0	96	19
591.70	2.50		34	Hard Till	3.7	63.5	238.1	5.5	8.1	187.2	187	0	0	103	21
589.20	2.50		65	Hard Till	9.8	121.4	343.2	14.4	15.5	213.8	214	0	0	118	24
586.70	2.50		116	Hard Till	28.7	216.7	1276.2	42.1	27.7	371.5	371	0	0	204	26
585.20	1.50		600	Hard Till	453.5	1121.1	857.8	667.0	143.3	927.1	858	0	0	472	28
584.20	1.00			Limestone	99.7	249.1	957.4	146.6	31.8	1073.6	957	0	0	527	28.8
583.20	1.00			Limestone	99.7	249.1	1057.1	146.6	31.8	1220.2	1057	0	0	581	29.8
582.20	1.00			Limestone	99.7	249.1	1156.8	146.6	31.8	1366.8	1157	0	0	636	30.8
581.20	1.00			Limestone	99.7	249.1	1256.4	146.6	31.8	1513.4	1256	0	0	691	31.8
580.20	1.00			Limestone	99.7	249.1	1356.1	146.6	31.8	1660.0	1356	0	0	746	32.8
579.20	1.00			Limestone	99.7	249.1	1455.7	146.6	31.8	1806.5	1456	0	0	801	33.8
578.20	1.00			Limestone	99.7	249.1	1555.4	146.6	31.8	1953.1	1555	0	0	855	34.8
577.20	1.00			Limestone	99.7	249.1	1655.0	146.6	31.8	2099.7	1655	0	0	910	35.8
576.20	1.00			Limestone	99.7	249.1	1754.7	146.6	31.8	2246.3	1755	0	0	965	36.8
575.20	1.00			Limestone	99.7	249.1	1854.4	146.6	31.8	2392.9	1854	0	0	1020	37.8
574.20	1.00			Limestone		249.1			31.8						

SUBSTRUCTURE===== Abutments using 2019 boring
 REFERENCE BORING ===== 01 sta 967+18 16 Lt
 LRFD or ASD or SEISMIC ===== LRFD
 PILE CUTOFF ELEV. ===== 613.00 ft
 GROUND SURFACE ELEV. AGAINST PILE DURING DRIVING = 611.00 ft
 GEOTECHNICAL LOSS TYPE (None, Scour, Liquef., DD) ===== None
 BOTTOM ELEV. OF SCOUR, LIQUEF., or DD ===== None ft
 TOP ELEV. OF LIQUEF. (so layers above apply DD) ===== None ft

MAX. REQUIRED BEARING & RESISTANCE for Selected Pile, Soil Profile, & Losses

Maximum Nominal Req'd Bearing of Pile	Maximum Nominal Req'd Bearing of Boring	Maximum Factored Resistance Available in Boring	Maximum Pile Driveable Length in Boring
578 KIPS	578 KIPS	318 KIPS	28 FT.

TOTAL FACTORED SUBSTRUCTURE LOAD ===== 1920 kips
 TOTAL LENGTH OF SUBSTRUCTURE (along skew)===== 38.83 ft
 NUMBER OF ROWS OF PILES PER SUBSTRUCTURE ===== 1

This sheet is superseded by revised calculations. See memo dated 8/31/2020 for more information

Approx. Factored Loading Applied per pile at 8 ft. Cts ===== 395.57 KIPS
 Approx. Factored Loading Applied per pile at 3 ft. Cts ===== 148.34 KIPS

PILE TYPE AND SIZE ===== Steel HP 14 X 73

Plugged Pile Perimeter===== 4.700 FT. Unplugged Pile Perimeter===== 6.975 FT.
 Plugged Pile End Bearing Area===== 1.379 SQFT. Unplugged Pile End Bearing Area===== 0.149 SQFT.

BOT. OF LAYER ELEV. (FT.)	LAYER THICK. (FT.)	UNCONF. COMPR. STRENGTH (TSF.)	S.P.T. N VALUE (BLOWS)	GRANULAR OR ROCK LAYER DESCRIPTION	NOMINAL PLUGGED			NOMINAL UNPLUG'D			NOMINAL REQ'D BEARING (KIPS)	FACTORED GEOTECH. LOSS FROM SCOUR or DD (KIPS)	FACTORED GEOTECH. LOSS LOAD FROM DD (KIPS)	FACTORED RESISTANCE AVAILABLE (KIPS)	ESTIMATED PILE LENGTH (FT.)
					SIDE RESIST. (KIPS)	END BRG. RESIST. (KIPS)	TOTAL RESIST. (KIPS)	SIDE RESIST. (KIPS)	END BRG. RESIST. (KIPS)	TOTAL RESIST. (KIPS)					
608.70	2.30	1.50	3		10.4		49.0	15.4		19.6	20	0	0	11	4
606.20	2.50	2.00	7		13.7	38.6	62.7	20.3	4.2	39.9	40	0	0	22	7
604.20	2.00	2.00	3		10.9	38.6	135.5	16.2	4.2	62.8	63	0	0	35	9
601.70	2.50	5.20	12		24.4	100.5	152.2	36.2	10.8	98.2	98	0	0	54	11
599.20	2.50	4.80	13		24.4	92.8	180.5	36.2	10.0	134.9	135	0	0	74	14
596.70	2.50	5.00	14		24.4	96.6	237.8	36.2	10.4	174.7	175	0	0	96	16
594.20	2.50	6.70	20		24.4	129.5	220.3	36.2	14.0	206.4	206	0	0	114	19
591.70	2.50		34	Hard Till	4.4	87.6	304.6	6.5	9.4	221.5	222	0	0	122	21
589.20	2.50		65	Hard Till	11.5	167.5	447.5	17.1	18.0	252.8	253	0	0	139	24
586.70	2.50		116	Hard Till	33.7	298.9	1728.2	50.0	32.2	437.1	437	0	0	240	26
585.20	1.50		600	Hard Till	532.9	1545.9	1058.7	790.8	166.6	1098.4	1099	0	0	582	28
584.20	1.00			Limestone	117.1	343.5	1175.8	173.8	37.0	1272.1	1176	0	0	647	28.8
583.20	1.00			Limestone	117.1	343.5	1292.9	173.8	37.0	1445.9	1293	0	0	711	29.8
582.20	1.00			Limestone	117.1	343.5	1410.0	173.8	37.0	1619.7	1410	0	0	775	30.8
581.20	1.00			Limestone	117.1	343.5	1527.1	173.8	37.0	1793.5	1527	0	0	840	31.8
580.20	1.00			Limestone	117.1	343.5	1644.2	173.8	37.0	1967.2	1644	0	0	904	32.8
579.20	1.00			Limestone	117.1	343.5	1761.3	173.8	37.0	2141.0	1761	0	0	969	33.8
578.20	1.00			Limestone	117.1	343.5	1878.4	173.8	37.0	2314.8	1878	0	0	1033	34.8
577.20	1.00			Limestone	117.1	343.5	1995.5	173.8	37.0	2488.6	1995	0	0	1098	35.8
576.20	1.00			Limestone	117.1	343.5	2112.6	173.8	37.0	2662.4	2113	0	0	1162	36.8
575.20	1.00			Limestone	117.1	343.5	2229.7	173.8	37.0	2836.1	2230	0	0	1226	37.8
574.20	1.00			Limestone		343.5			37.0						

SUBSTRUCTURE===== Abutments using 2019 boring
 REFERENCE BORING ===== 01 sta 967+18 16 Lt
 LRFD or ASD or SEISMIC ===== LRFD
 PILE CUTOFF ELEV. ===== 613.00 ft
 GROUND SURFACE ELEV. AGAINST PILE DURING DRIVING = 611.00 ft
 GEOTECHNICAL LOSS TYPE (None, Scour, Liquef., DD) ===== None
 BOTTOM ELEV. OF SCOUR, LIQUEF., or DD ===== None ft
 TOP ELEV. OF LIQUEF. (so layers above apply DD) ===== None ft

MAX. REQUIRED BEARING & RESISTANCE for Selected Pile, Soil Profile, & Losses

Maximum Nominal Req'd Bearing of Pile	Maximum Nominal Req'd Bearing of Boring	Maximum Factored Resistance Available in Boring	Maximum Pile Driveable Length in Boring
705 KIPS	705 KIPS	388 KIPS	28 FT.

This sheet is superseded by revised calculations. See memo dated 8/31/2020 for more information

TOTAL FACTORED SUBSTRUCTURE LOAD ===== 1920 kips
 TOTAL LENGTH OF SUBSTRUCTURE (along skew)===== 38.83 ft
 NUMBER OF ROWS OF PILES PER SUBSTRUCTURE ===== 1
 Approx. Factored Loading Applied per pile at 8 ft. Cts ===== 395.57 KIPS
 Approx. Factored Loading Applied per pile at 3 ft. Cts ===== 148.34 KIPS

PILE TYPE AND SIZE ===== Steel HP 14 X 89

Plugged Pile Perimeter===== 4.750 FT. Unplugged Pile Perimeter===== 7.033 FT.
 Plugged Pile End Bearing Area===== 1.409 SQFT. Unplugged Pile End Bearing Area===== 0.181 SQFT.

BOT. OF LAYER ELEV. (FT.)	LAYER THICK. (FT.)	UNCONF. COMPR. STRENGTH (TSF.)	S.P.T. N VALUE (BLOWS)	GRANULAR OR ROCK LAYER DESCRIPTION	NOMINAL PLUGGED			NOMINAL UNPLUG'D			NOMINAL REQ'D BEARING (KIPS)	FACTORED GEOTECH. LOSS FROM SCOUR or DD (KIPS)	FACTORED GEOTECH. LOSS LOAD FROM DD (KIPS)	FACTORED RESISTANCE AVAILABLE (KIPS)	ESTIMATED PILE LENGTH (FT.)
					SIDE RESIST. (KIPS)	END BRG. RESIST. (KIPS)	TOTAL RESIST. (KIPS)	SIDE RESIST. (KIPS)	END BRG. RESIST. (KIPS)	TOTAL RESIST. (KIPS)					
608.70	2.30	1.50	3		10.5		50.0	15.6		20.6	21	0	0	11	4
606.20	2.50	2.00	7		13.8	39.5	63.8	20.5	5.1	41.1	41	0	0	23	7
604.20	2.00	2.00	3		11.1	39.5	138.0	16.4	5.1	65.6	66	0	0	36	9
601.70	2.50	5.20	12		24.7	102.7	154.8	36.6	13.2	101.1	101	0	0	56	11
599.20	2.50	4.80	13		24.7	94.8	183.5	36.6	12.2	138.2	138	0	0	76	14
596.70	2.50	5.00	14		24.7	98.7	241.7	36.6	12.7	179.1	179	0	0	98	16
594.20	2.50	6.70	20		24.7	132.3	223.6	36.6	17.0	210.1	210	0	0	116	19
591.70	2.50		34	Hard Till	4.4	89.5	309.7	6.6	11.5	227.2	227	0	0	125	21
589.20	2.50		65	Hard Till	11.6	171.1	455.6	17.2	22.0	261.7	262	0	0	144	24
586.70	2.50		116	Hard Till	34.0	305.4	1763.6	50.4	39.3	476.1	476	0	0	262	26
585.20	1.50		600	Hard Till	538.5	1579.4	1073.8	797.4	203.3	1115.4	1074	0	0	591	28
584.20	1.00			Limestone	118.3	351.0	1192.1	175.2	45.2	1290.6	1192	0	0	656	28.8
583.20	1.00			Limestone	118.3	351.0	1310.4	175.2	45.2	1465.8	1310	0	0	721	29.8
582.20	1.00			Limestone	118.3	351.0	1428.8	175.2	45.2	1641.1	1428	0	0	786	30.8
581.20	1.00			Limestone	118.3	351.0	1547.1	175.2	45.2	1816.3	1547	0	0	851	31.8
580.20	1.00			Limestone	118.3	351.0	1665.5	175.2	45.2	1991.5	1665	0	0	916	32.8
579.20	1.00			Limestone	118.3	351.0	1783.8	175.2	45.2	2166.8	1784	0	0	981	33.8
578.20	1.00			Limestone	118.3	351.0	1902.2	175.2	45.2	2342.0	1902	0	0	1046	34.8
577.20	1.00			Limestone	118.3	351.0	2020.5	175.2	45.2	2517.2	2020	0	0	1111	35.8
576.20	1.00			Limestone	118.3	351.0	2138.8	175.2	45.2	2692.5	2139	0	0	1176	36.8
575.20	1.00			Limestone	118.3	351.0	2257.2	175.2	45.2	2867.7	2257	0	0	1241	37.8
574.20	1.00			Limestone		351.0			45.2						