

LEGEND

- ① EXISTING B-6.24 COMB. CONC. CURB & GUTTER
- ② EXISTING SUB BASE
- ③ EXISTING HMA BASE COURSE, ±10"
- ④ EXISTING HMA SURFACE COURSE, ±3"
- ⑤ EXISTING CONCRETE BARRIER MEDIAN
- ⑥ PROPOSED HMA SURFACE REMOVAL, 2 1/2"
- ⑦ PROPOSED HMA SURFACE REMOVAL, 1 3/4"
- ⑧ PROPOSED POLYMERIZED HMA SURFACE COURSE, MIX "F", N90, 1-3/4"
- ⑨ PROPOSED POLYMERIZED LEVELING BINDER (MACHINE METHOD) COURSE, IL-4.75, N50, 3/4"

NOTE: CONTRACTOR SHALL MILL FIRST BEFORE PATCHING

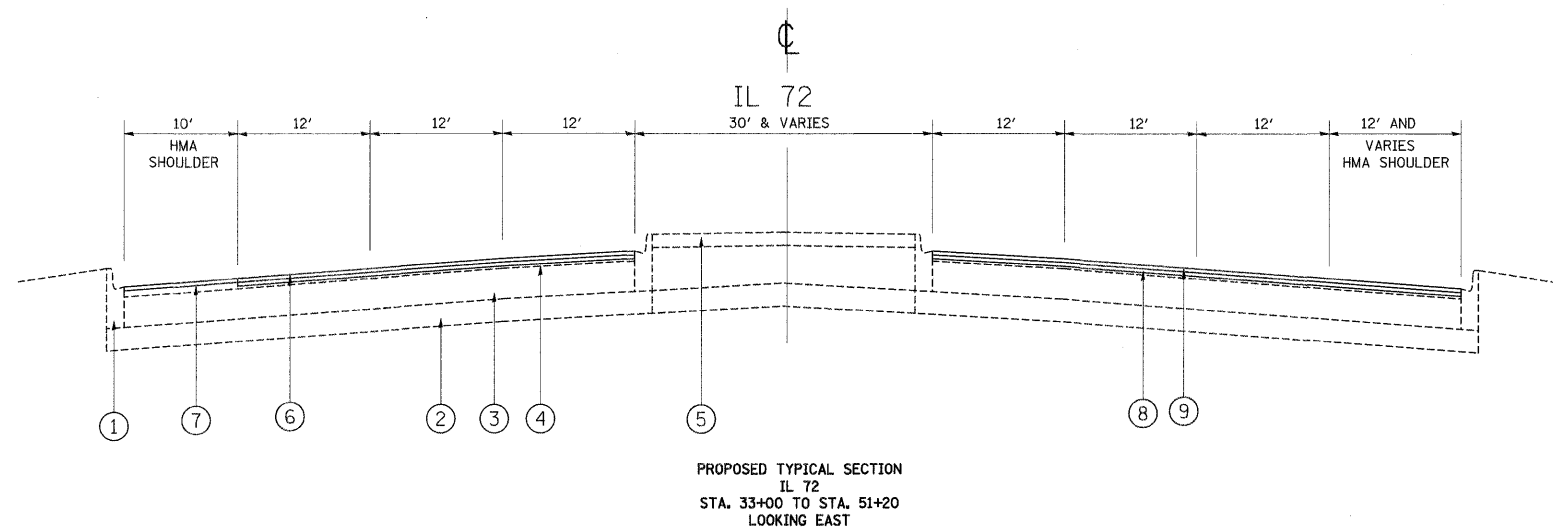

HOT-MIX ASPHALT MIXTURE REQUIREMENTS

MIXTURE TYPE	AC TYPE	AIR VOIDS (%)
POLYMERIZED LEVELING BINDER (MM), IL-4.75, N50	SBS/SBR 76-28/-22	4% @ 50 GYR
POLYMERIZED HMA SURFACE COURSE, MIX "F", N90	SBS/SBR PG 70-22	4% @ 90 GYR
BIT. REPLACEMENT OVER PATCHES, (HMA BINDER IL-19.0 MM)	PG 64-22 **	4% @ 70 GYR
CLASS D PATCHES, HMA BINDER IL-19 MM, 10"	PG 64-22 **	4% @ 70 GYR
HOT-MIX ASPHALT SURFACE COURSE, MIX "C", N50	PG 64-22	4% @ 50 GYR
HOT-MIX ASPHALT BASE COURSE	PG 64-22 / 58-22	4% @ 50 GYR

THE UNIT WEIGHT USED TO CALCULATE ALL HOT-MIX ASPHALT SURFACE MIXTURES QUANTITIES IS 112 LBS/SQ YD/IN

** WHEN RAP EXCEEDS 20 %, THE NEW ASPHALT BINDER IN THE MIX SHALL BE PG 58-22