

GILBERT STREET
STA 305+80.00 TO STA 312+48.81

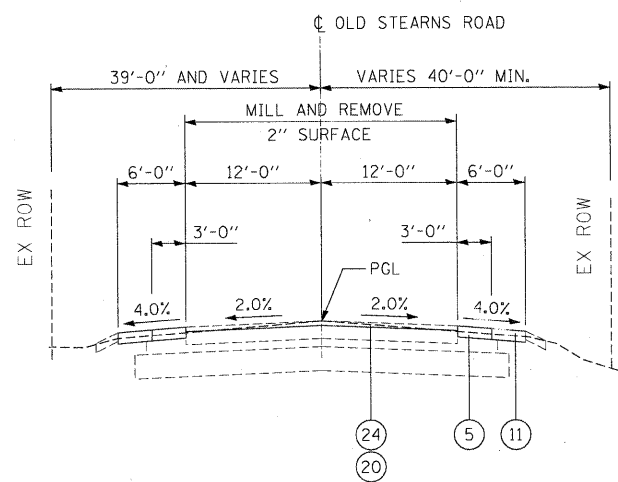

OLD STEARNS ROAD (RESURFACING AREA)
STA 800+00.00 TO STA 804+14.00

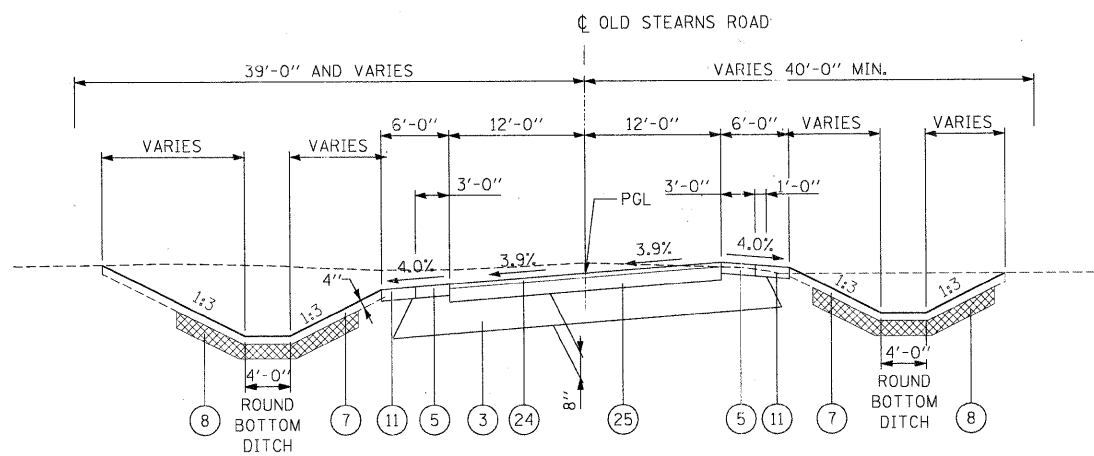

OLD STEARNS ROAD (RECONSTRUCTION AREA)
STA 804+14.00 TO STA 807+99.77
AND CUL DE SAC

LEGEND

- ① PORTLAND CEMENT CONCRETE PAVEMENT, 10" (JOINTED)
- ② STABILIZED SUB-BASE, HOT-MIX ASPHALT, 4 1/2"
- ③ SUB-BASE GRANULAR MATERIAL, TYPE B, 12" & VARIES
- ④ COMBINATION CONCRETE CURB AND GUTTER B6.24
- ⑤ HOT-MIX ASPHALT SHOULDERS, 8" (IN 3 LIFTS)
- ⑥ EARTH EXCAVATION
- ⑦ TOPSOIL EXCAVATION AND PLACEMENT
- ⑧ CLAY LINER, 8"
- ⑨ PORTLAND CEMENT CONCRETE SHOULDERS, 6"
- ⑩ LONGITUDINAL CONSTRUCTION JOINT (INCLUDED IN COST OF PORTLAND CEMENT CONCRETE PAVEMENT, 10" JOINTED)
- ⑪ AGGREGATE SHOULDERS TYPE B, 8"
- ⑫ POLYMERIZED HOT-MIX ASPHALT SURFACE COURSE, MIX "F", N90, 2"
- ⑬ HOT-MIX ASPHALT BINDER COURSE, IL-19.0, N70, 10 1/2" (IN 5 LIFTS)
- ⑭ AGGREGATE BASE COURSE TYPE B, 6"
- ⑮ GEOTECHNICAL FABRIC FOR GROUND STABILIZATION
- ⑯ COMPACTED LIMESTONE SCREENINGS (FA 5), 2" } PAID FOR AS ⑯ AGGREGATE PATH, 8"
- ⑰ STEEL PLATE BEAM GUARD RAIL, TYPE A
- ⑱ NOT USED
- ⑲ NOT USED
- ⑳ LEVELING BINDER (MACHINE METHOD), N70 (3/4" MINIMUM)
- ㉑ COMBINATION CONCRETE CURB AND GUTTER B6.12
- ㉒ CONCRETE MEDIAN, TYPE SB (SPEC)
- ㉓ BICYCLE RAILING
- ㉔ HOT MIX ASPHALT SURFACE COURSE, MIX "C", N50, 2"
- ㉕ HOT MIX ASPHALT BINDER COURSE, IL-19.0 N50, 6 1/2" (IN 3 LIFTS)
- ㉖ SAW CUTS
- ㉗ HOT-MIX ASPHALT SHOULDER, 6" (IN 2 LIFTS)
- ㉘ POLYMERIZED HOT-MIX ASPHALT SURFACE COURSE, MIX "D", N50, 1 1/2"
- ㉙ POLYMERIZED LEVELING BINDER (MACHINE METHOD) IL-4.75, N50, 1 1/2"
- ㉚ PORTLAND CEMENT CONCRETE PAVEMENT, 9"
- ㉛ TIE BARS (INCLUDED IN COST OF COMB CONC CURB & GUTTER AND CONC MEDIAN, TYPE SB (SPEC))

x:\39928\3994\engineering\documents\roadway\typical_sections\prp\in_48c_tup15.dgn

FILE NAME =	USER NAME = #USER#	DESIGNED - JRM	REVISED -	KANE COUNTY DIVISION OF TRANSPORTATION	PROPOSED TYPICAL SECTION GILBERT STREET / OLD STEARNS ROAD	F.A. RTE.	SECTION	COUNTY	TOTAL SHEETS	SHEET NO.
#FILES#		DRAWN - INS	REVISED -			361	06-00214-15-BR	KANE/DUPAGE	545	33
PLOT SCALE = 8.3380' / IN.		CHECKED - JNR	REVISED -			CONTRACT NO. 63074				
PLOT DATE = 4/27/2009		DATE - 3/31/09	REVISED -			FED. ROAD DIST. NO. ILLINOIS FED. AID PROJECT				
					SCALE:	SHEET NO. OF SHEETS		STA. TO STA.		