

TRAFFIC SIGNAL POST - MOUNTING BASE - TYPE A

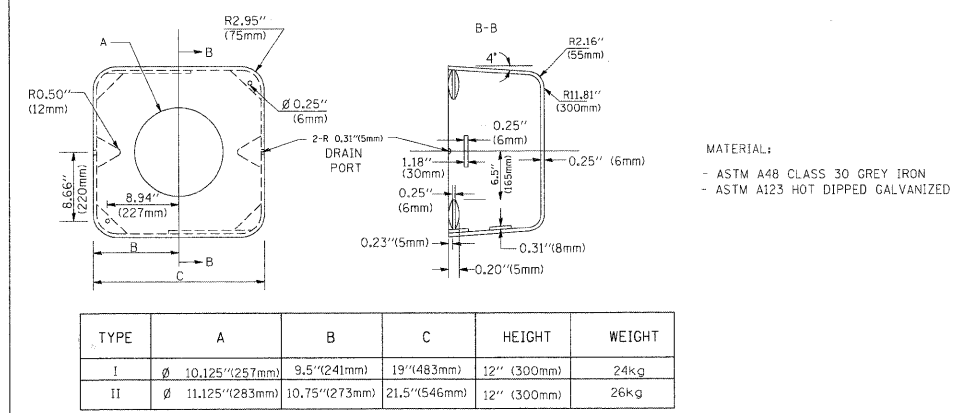

TYPE	A	B	C	HEIGHT	WEIGHT
I	Ø 10.125\" (257mm)	9.5\" (241mm)	19\" (483mm)	12\" (300mm)	24kg
II	Ø 11.125\" (283mm)	10.75\" (273mm)	21.5\" (546mm)	12\" (300mm)	26kg

SHROUD DETAIL

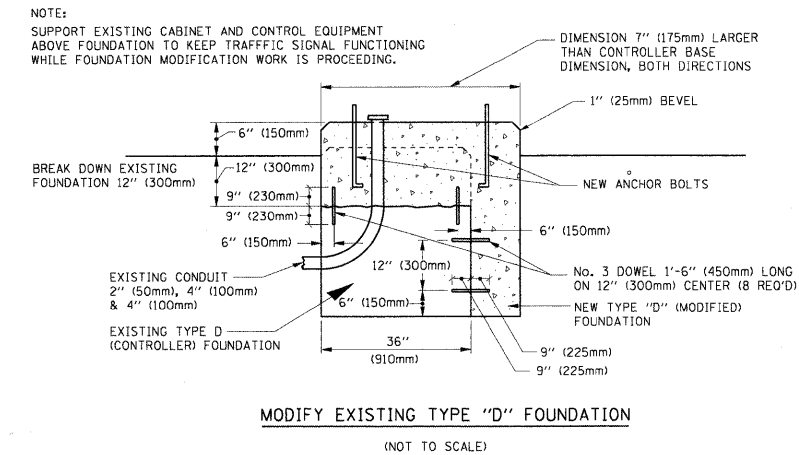

MODIFY EXISTING TYPE "D" FOUNDATION

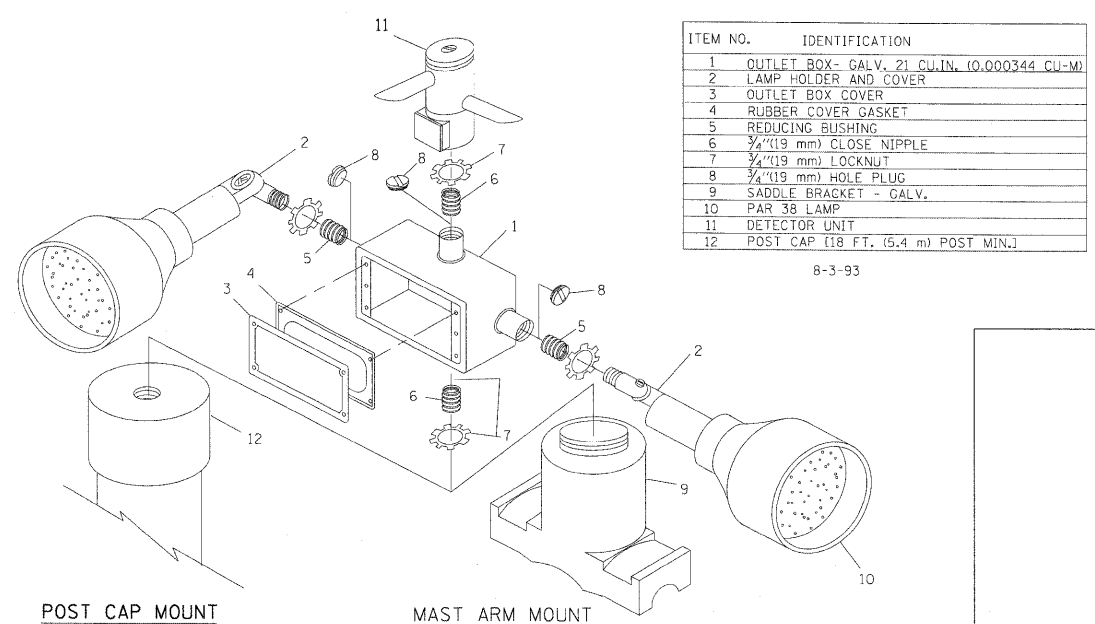

EMERGENCY VEHICLE DETECTOR WITH CONFIRMATION BEACON MOUNTING DETAIL

- NOTES:
- ALL ELECTRICAL ITEMS, EXCEPT ITEMS #2 AND #11 SHALL BE ALUMINUM OR GALVANIZED
 - ITEM #1- OZ/GEDNEY FSX-1-50 OR EQUIVALENT
ITEM #2- MULBERRY CON-O-SHADE LAMP SHIELD OR EQUIVALENT
ITEM #9- "BAND-IT" SADDLE BRACKET OR EQUIVALENT
 - WHEN POST MOUNTING IS SPECIFIED, ITEM #9 SHALL NOT BE REQUIRED. THE DETECTION UNIT SHALL BE MOUNTED DIRECTLY ON TOP OF THE CAP BY DRILLING AND TAPPING A 3/4\" (19 mm) HOLE WITH PIPE THREADS. THE POST CAP SHALL EITHER BE SCREWED TO THE TOP OF THE POST OR A MINIMUM OF 3 TIGHTENING SCREWS SHALL BE REQUIRED ON EACH CAP.

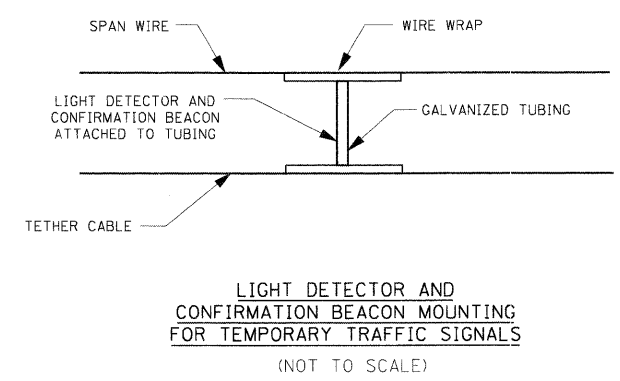

LIGHT DETECTOR AND CONFIRMATION BEACON MOUNTING FOR TEMPORARY TRAFFIC SIGNALS (NOT TO SCALE)

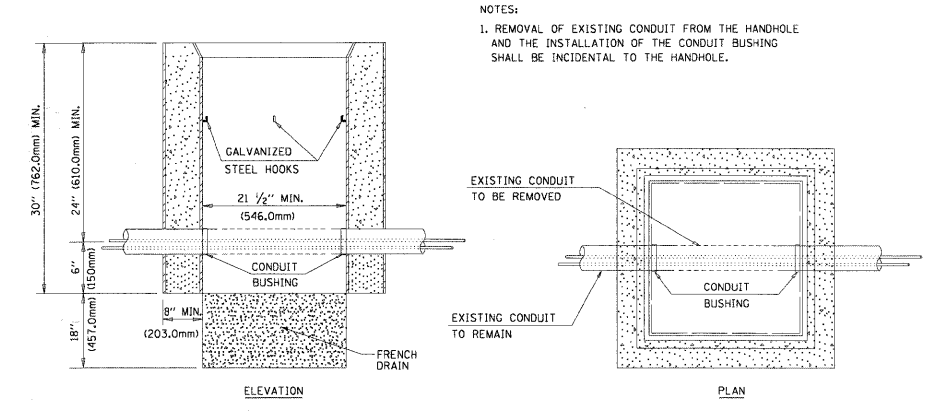

DETAIL HANDHOLE TO INTERCEPT EXISTING CONDUIT N.T.S.