

SECTION A-A
DETAILS AT ENTRANCES & SIDE ROADS

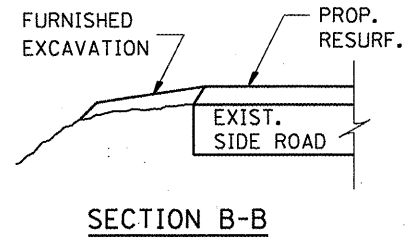

SECTION B-B

THE COST OF REMOVAL AT EXISTING HMA OR P.C.C. LOCATIONS SHALL BE PAID FOR PER SQ. YD. BY THE APPROPRIATE PAY ITEM. REMOVAL AT THE EXISTING AGG. LOCATIONS SHALL BE INCIDENTAL TO THE HMA. A-3 LOCATIONS SHALL BE FEATHER TAPERED.

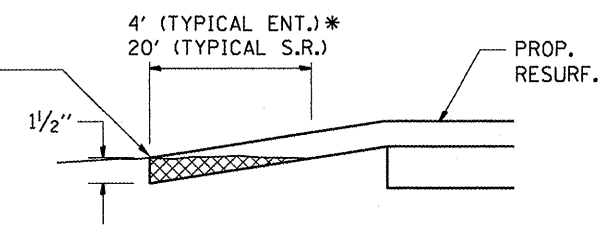

DETAIL A

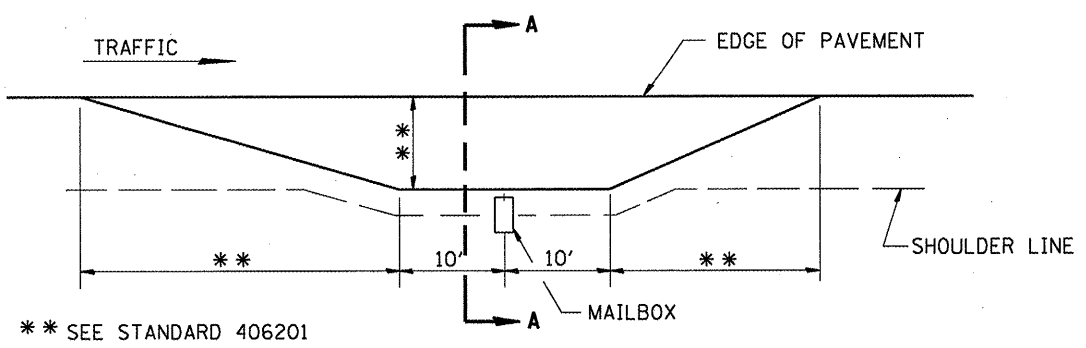

SECTION A-A
MAILBOX TURNOUT DETAILS

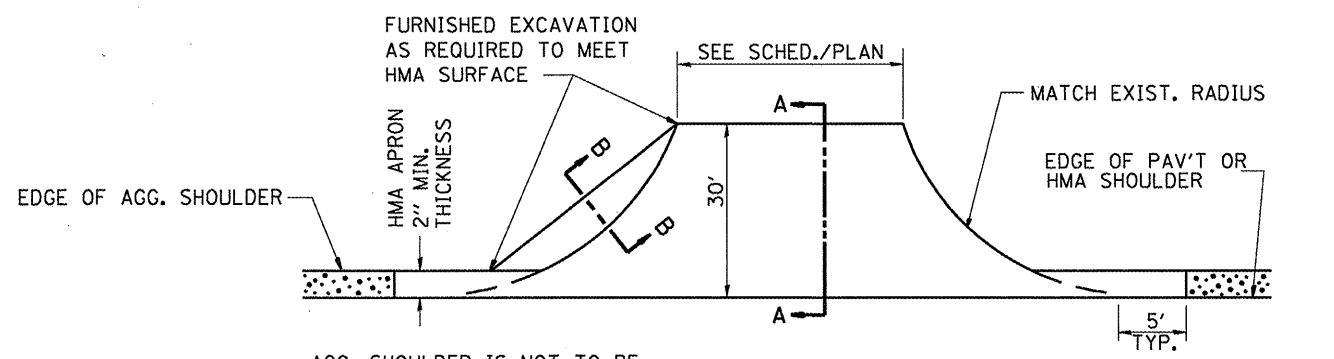

PLAN AT SIDE ROADS

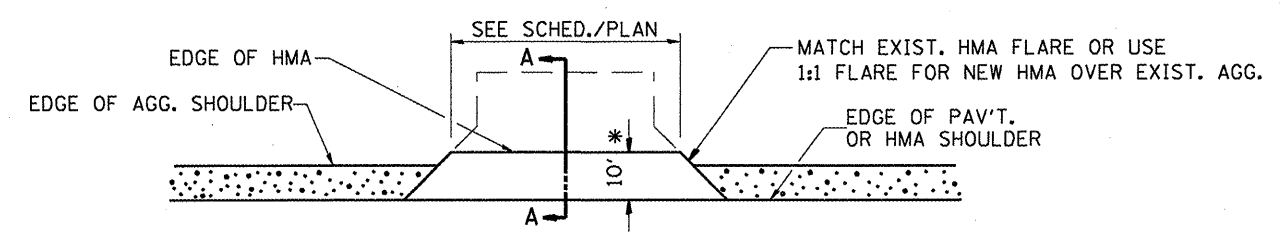

PLAN AT PRIVATE & COMMERCIAL ENTRANCES
(DO NOT RESURFACE FIELD ENTRANCES)

* PROPOSED HMA RESURFACING AT PUBLIC EDUCATIONAL FACILITY ENTRANCES SHALL BE EXTENDED TO THE RIGHT-OF-WAY LIMITS.

FILE NAME =	USER NAME = sohwankeg	DESIGNED -	REVISED -	STATE OF ILLINOIS DEPARTMENT OF TRANSPORTATION	ENTRANCE AND SIDEROAD DETAILS			F.A.P. RTE.	SECTION	COUNTY	TOTAL SHEETS	SHEET NO.		
cr\pwork\PIWIDOT\SCHWANKERG\d0131387	lahsa.dgn	DRAWN -	REVISED -		SCALE:	SHEET NO.	OF SHEETS	STA.	TO STA.	311	(3)RS-2	LASALLE	8	8
	PLOT SCALE = 40.0000' / IN.	CHECKED -	REVISED -									CONTRACT NO.		
	PLOT DATE = Apr 01, 2009 - 11:44:10 AM	DATE -	REVISED -									ILLINOIS FED. AID PROJECT		