

SEE PLAN VIEW
FOR STRIPING

ANNIE GLIDDEN RD.
NORTH LEG
MAINTAIN EXIST. CROSS SLOPE

	HMA SURFACE	HMA LEVEL BINDER	HMA SHOULDER
PG GRADE	PG64-22	PG64-22	PG58-22
MAX. % RAP ALLOWABLE **	15	25	50
DESIGN AIR VOIDS	4.0% @ N70	4.0% @ N70	2% N. 30
MIXTURE COMPOSITION	IL 12.5 OR IL 9.5	IL 9.5	OTHER
FRICTION AGGREGATE	MIXTURE D		
DENSITY TEST METHOD	CORES OR CORRETATION	SATISFACTION OF ENGINEER	CORES

** When more than 20 percent RAP is used, a softer asphalt binder (PG58-22) may be required as determined by the Engineer.

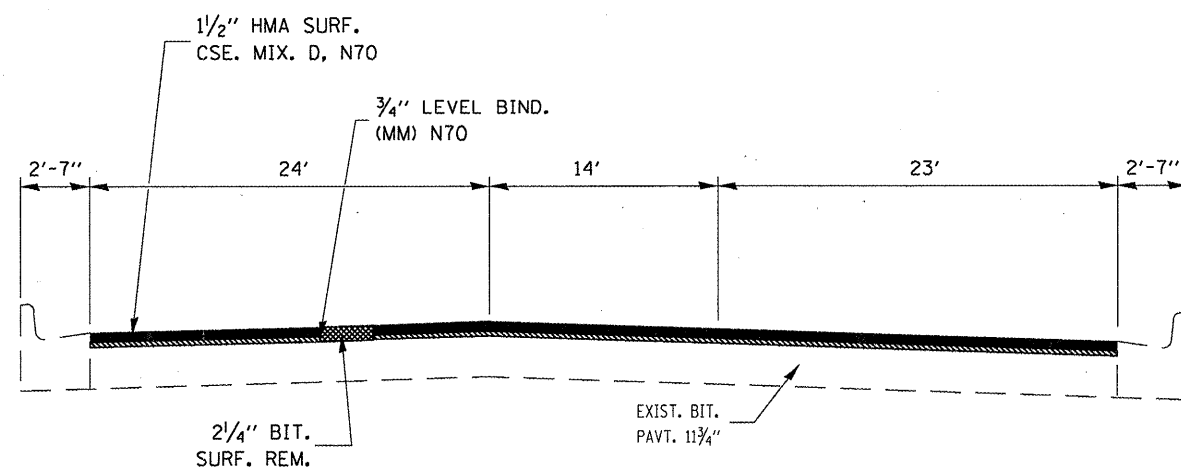

ANNIE GLIDDEN RD.
SOUTH LEG
MAINTAIN EXIST. CROSS SLOPE

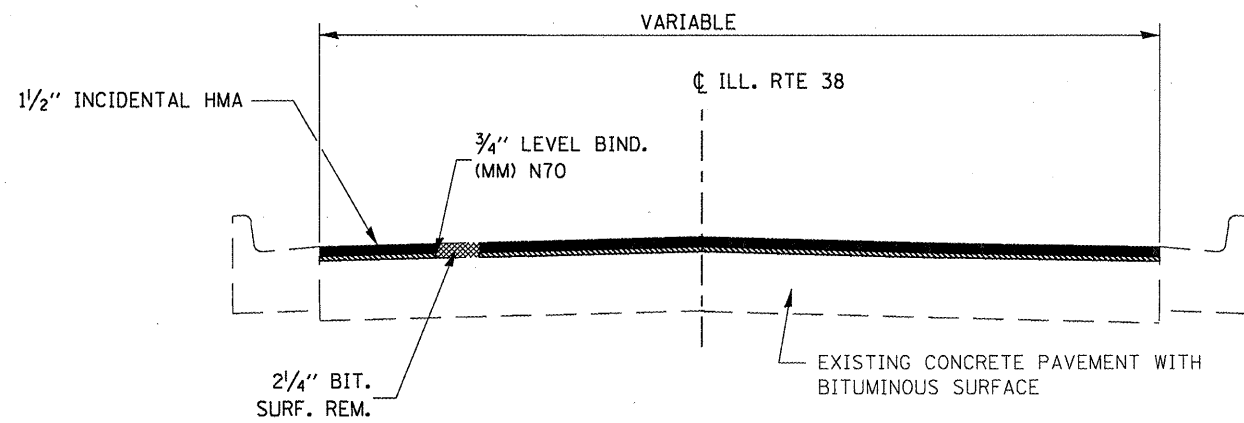

SIDE ROADS & ENTRANCES

FILE NAME =	USER NAME = schwankerg	DESIGNED -	REVISED -
ct:\pwwork\pwwid\DOT\SCHWANKERG\0120874\366747-sht-details.DGN	366747-sht-details.DGN	DRAWN -	REVISED -
PLOT SCALE = 100.0000' / IN.		CHECKED -	REVISED -
PLOT DATE = Mar 24, 2009 - 10:02:35 AM		DATE -	REVISED -

**STATE OF ILLINOIS
DEPARTMENT OF TRANSPORTATION**

TYPICAL SECTIONS			
SCALE:	SHEET NO.	OF SHEETS	STA. TO STA.

F.A.P. RTE.	SECTION	COUNTY	TOTAL SHEETS	SHEET NO.
567	(34)RS-5 & (7)RS-3, I	DEKALB	35	6
CONTRACT NO. 66747				
ILLINOIS FED. AID PROJECT				