

STA. 153+65.00 TO STA. 159+30.00
 STA. 163+11.00 TO STA. 165+10.00

LEGEND - PROPOSED

- ① HMA SURFACE REMOVAL, 2"
- ② POLYMERIZED LEVELING BINDER (MM), IL-4.75, N50 (3/4")
- ③ HMA SURFACE COURSE, MIX "D", N50 (1 1/2")
- ④ STRIP REFLECTIVE CRACK CONTROL TREATMENT
- ⑤ EPOXY PAVEMENT MARKING
- ⑥ HMA SHOULDERS
- ⑦ AGGREGATE SHOULDER, TYPE B

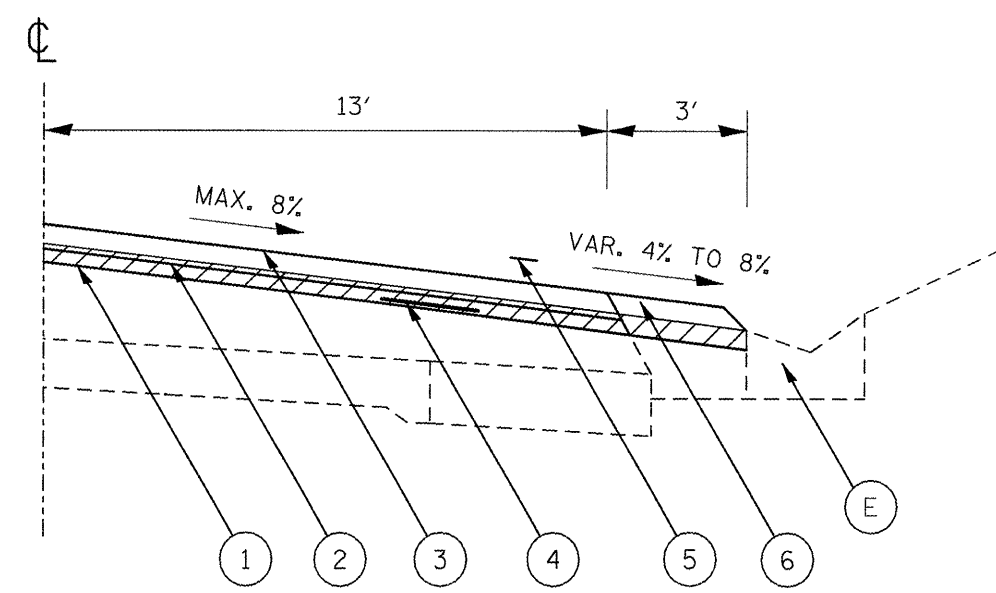

STA. 159+30.00 TO STA. 163+11.00

LEGEND - EXISTING

- Ⓐ P.C.C. PAVEMENT (9-6-9)
- Ⓑ HMA OVERLAY
- Ⓒ HMA BASE CSE/ BASE CSE WIDENING
- Ⓓ AGGREGATE SHOULDERS
- Ⓔ P.C.C. GUTTER TYPE A OR TYPE B (MOD)
- Ⓕ HMA SHOULDERS