

- LEGEND**
- (A) PROPOSED HMA SURFACE REMOVAL, 2 1/4"
  - (B) PROPOSED POLYMERIZED HMA SURFACE COURSE, MIX "D", N90, 1 1/2"
  - (C) PROPOSED LEVELING BINDER (MACHINE METHOD), N90, 3/4"
  - (D) PROPOSED AGGREGATE SHOULDER, TYPE B, 2"
  - (E) PROPOSED STRIP REFLECTIVE CRACK CONTROL TREATMENT
  - (F) PROPOSED HMA SHOULDERS, 8"

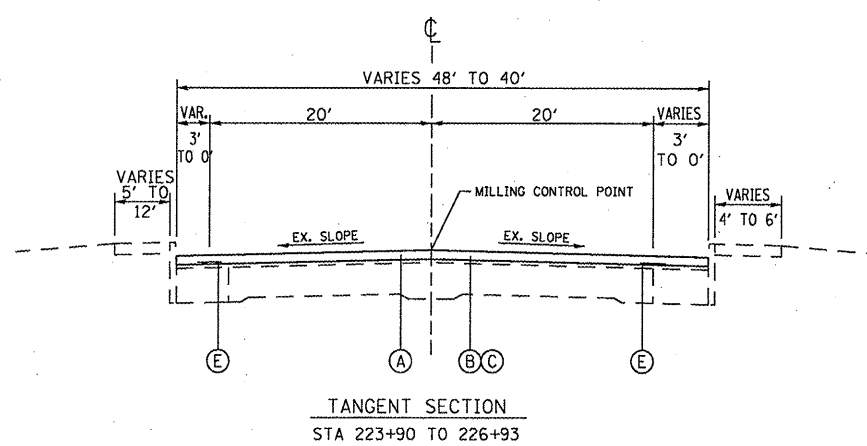
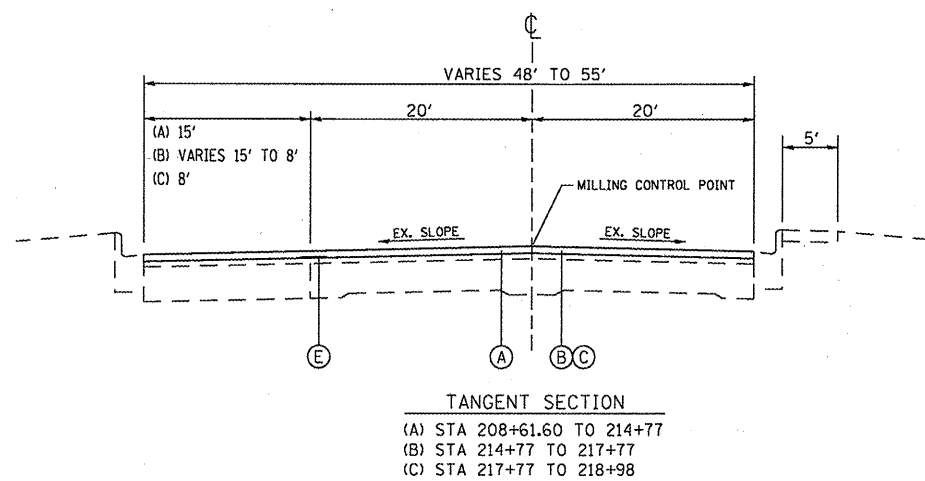

FILE NAME =	USER NAME = #USER#	DESIGNED -	REVISED -
#FILE#		DRAWN -	REVISED -
	PLOT SCALE = #SCALE#	CHECKED -	REVISED -
	PLOT DATE = #DATE#	DATE -	REVISED -

**STATE OF ILLINOIS  
DEPARTMENT OF TRANSPORTATION**

**PROPOSED TYPICAL SECTIONS**

SCALE: \_\_\_\_\_ SHEET NO. 2 OF 4 SHEETS STA. \_\_\_\_\_ TO STA. \_\_\_\_\_

F.A.P. RTE.	SECTION	COUNTY	TOTAL SHEETS	SHEET NO.
594	(61-63)RS-3	MADISON	40	9
CONTRACT NO. 76B71				
FED. ROAD DIST. NO. _____ ILLINOIS FED. AID PROJECT				