

FAS NO	SECTION	COUNTY	TOTAL SHEETS	SHEET NO.
339	09-00113-00-RS		3	3
PROJECT RS- 0339(111)				
CONTRACT # 87399				

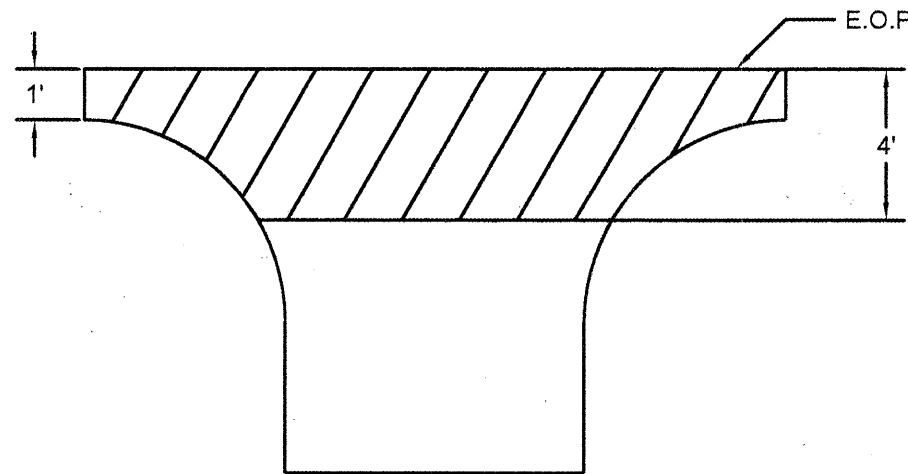

TYPICAL FIELD & PRIVATE ENTRANCE

33 EACH

LT. STA.	LT. STA.	RT. STA.	RT. STA.
20+32	131+28	13+63	133+53
27+03	140+81	16+73	146+72
44+68	175+79	33+34	158+66
65+44	182+21	42+57	174+88
82+60	183+03	80+41	186+80
93+43	200+08	82+03	200+08
106+89	206+99	93+43	207+50
119+45	212+10	99+35	208+58
		116+90	

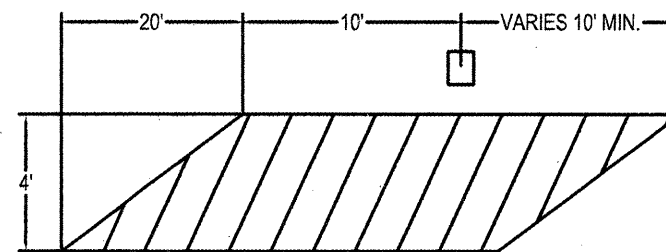

TYPICAL MAILBOX FOLLOWING

2 EACH
STA. 13+89 RT
STA. 208+58 RT

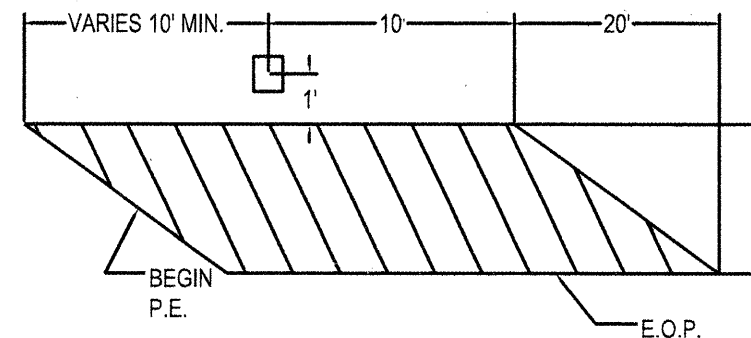

TYPICAL MAILBOX LEAD IN

1 EACH
STA. 207+50 RT

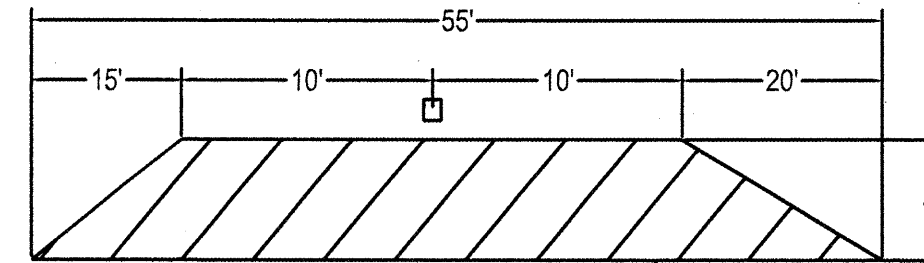

TYPICAL MAILBOX TURN OUT

2 EACH
STA. 116+90 LT
STA. 183+03 RT

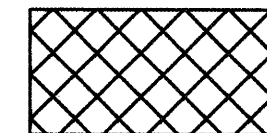

AREA TO BE PAID AS
INCIDENTAL BITUMINOUS SURFACING

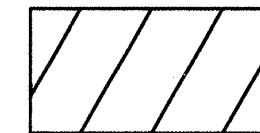

AREA TO BE CONSTRUCTED
DURING MAINLINE PAVING OPERATIONS
SLOPE = 3/4" PER FOOT

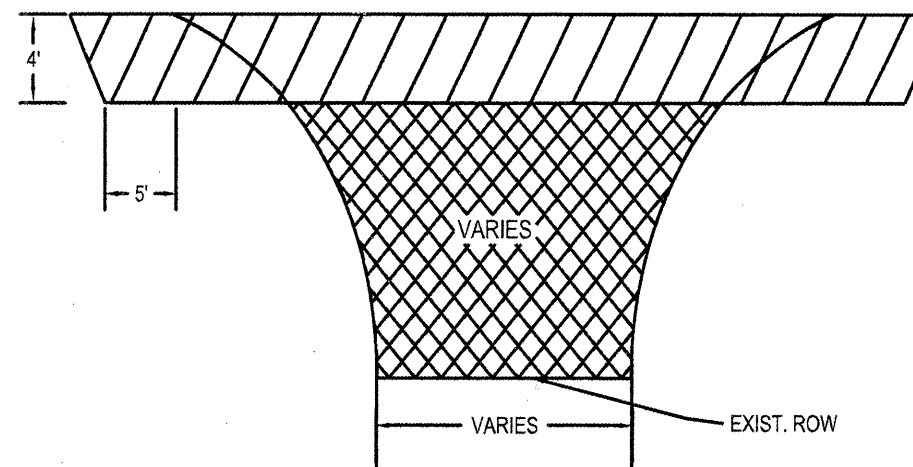

TYPICAL SIDE ROAD RETURN

7 EACH
STA. 0+43 RT & LT
STA. 53+66 RT & LT
STA. 106+89 RT ONLY
STA. 160+13 RT & LT

NOTES

1. USE SAME MAINLINE MATERIAL FOR SIDE ROAD RETURNS, FIELD & PRIVATE ENTRANCES, AND MAILBOXES.
2. AGGREGATE SHOULDERS TO BE PLACED BEHIND SIDE ROAD RETURNS, FIELD & PRIVATE ENTRANCES, AND MAILBOXES AS DIRECTED BY THE ENGINEER.
3. SHORT TERM PAVEMENT MARKINGS TO BE REMOVED BY FORD COUNTY PERSONNEL.
4. THE FOLLOWING APPLICATION RATES HAVE BEEN ASSUMED IN CALCULATING QUANTITIES:

GRANULAR MATERIALS	2.00 TON / CU YD
BIT MATL (PR CT)	0.075 GAL / SQ YD
AGGREGATE (PR CT)	0.001 TON / SQ YD
BIT CONC	112 # / SQ YD / INCH
SHORT TERM PVMT MKING	4 FT / 40 FT OF APPL.