

TYPICAL SECTION - SIDEWALK

STA. 5+92.98 TO STA. 19+70.88 (FIRST STREET)
 STA. 20+29.13 TO STA. 23+25 (SOUTH STREET)

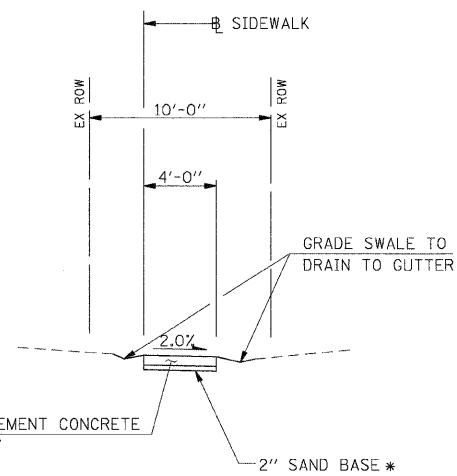

TYPICAL SECTION - SIDEWALK

BETWEEN LOTS 105 & 101 (BROOKSIDE GLEN DRIVE)

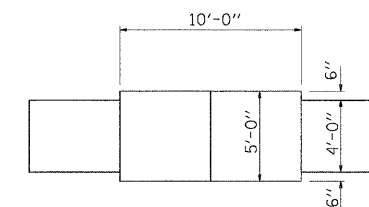

PLAN - PASSING SPACE

DISTANCE BETWEEN PASSING SPACES SHALL BE 200' MAX.

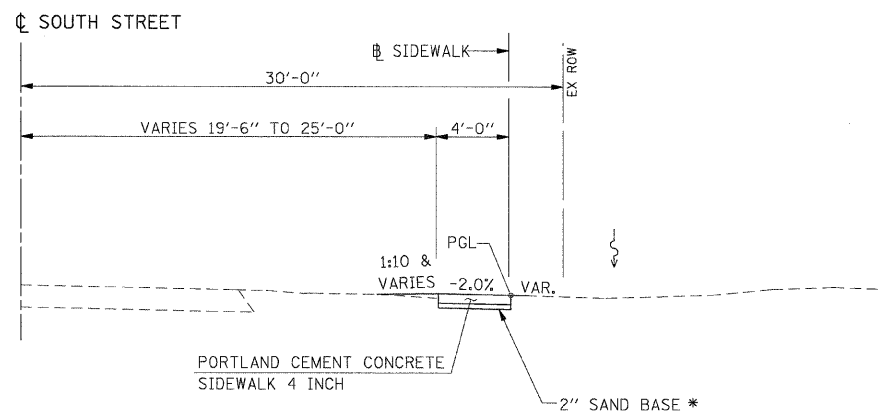

TYPICAL SECTION - SIDEWALK

STA. 23+25 TO STA. 27+34.80 (SOUTH STREET)

* SAND BASE SHALL NOT BE PAID FOR SEPERATELY BUT SHALL BE INCLUDED IN THE COST FOR PORTLAND CEMENT CONCRETE SIDEWALK, 4 INCH.

FILE NAME = G:\S27229-01\oad\72091501.dgn	USER NAME = IE Consultants	DESIGNED -	REVISED -	VILLAGE OF SHERMAN	SIDEWALK TYPICAL SECTIONS	F.A. RTE.	SECTION	COUNTY	TOTAL SHEETS	SHEET NO.	
	PLOT SCALE = 5,0000' / IN.	DRAWN -	REVISED -			08-00014-00-SW	SANGAMON	47	10		
	PLOT DATE = 2/12/2009	CHECKED -	REVISED -			CONTRACT NO. 93486					
		DATE -	REVISED -			SCALE:	SHEET NO. OF SHEETS	STA. TO STA.	FED. ROAD DIST. NO.	ILLINOIS FED. AID PROJECT	