

EXISTING RUNWAY PAVEMENT - TYPICAL SECTION

"NOT TO SCALE"

RUNWAY 6-24 STA. 365+90 TO STA. 375+50

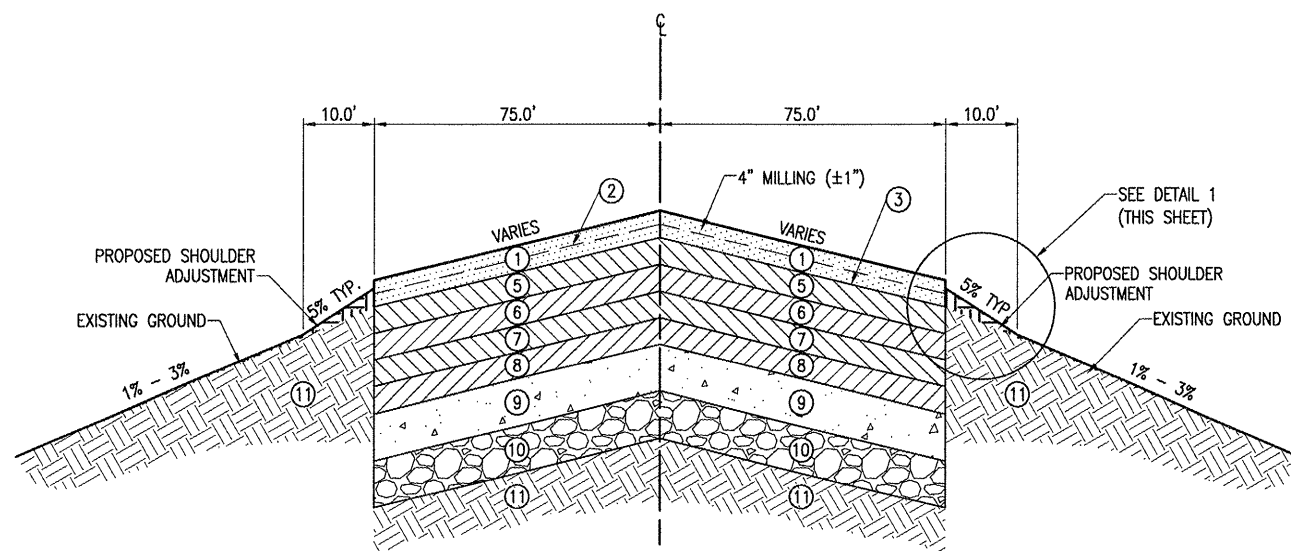

PROPOSED RUNWAY PAVEMENT - TYPICAL SECTION

"NOT TO SCALE"

RUNWAY 6-24 STA. 365+90 TO STA. 375+50

LEGEND FOR TYPICAL SECTION

- ① PROPOSED AR401: BITUMINOUS SURFACE COURSE - 4" (2 LIFTS)
 - ② PROPOSED AR603: BITUMINOUS TACK COAT (0.05 GAL/SYD)
 - ③ PROPOSED AR603: BITUMINOUS TACK COAT (0.20 GAL/SYD)
 - ④ EXISTING AR401: BITUMINOUS SURFACE COURSE - 4"
 - ⑤ EXISTING AR201: BITUMINOUS BASE COURSE - 2"-3"
 - ⑥ EXISTING AR401: BITUMINOUS SURFACE COURSE - 2"
 - ⑦ EXISTING AR201: BITUMINOUS BASE COURSE - 0"-10" VARIABLE DEPTH
 - ⑧ EXISTING AR401: BITUMINOUS SURFACE COURSE - 4"
 - ⑨ EXISTING AR501: PCC PAVEMENT - 9"
 - ⑩ EXISTING AR208: AGGREGATE SUBBASE COURSE - 8"
 - ⑪ EXISTING GROUND
- BITUMINOUS MILLING - VARIABLE 3" TO 5"

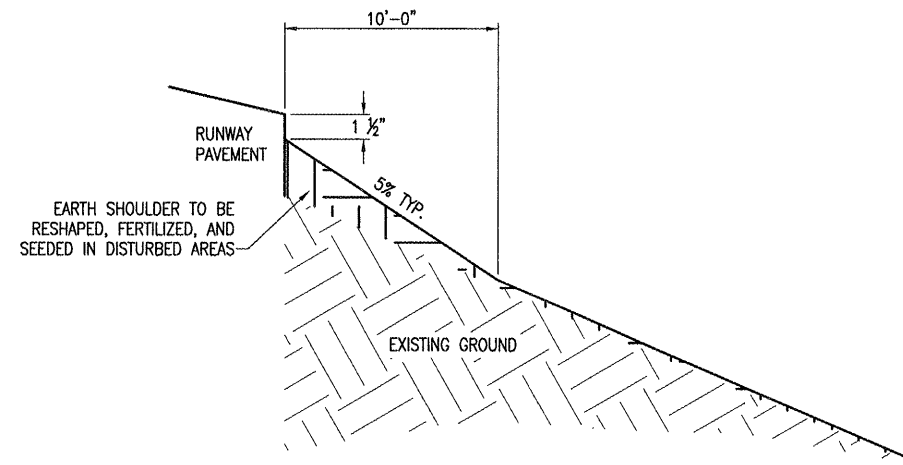

DETAIL 1
EARTH SHOULDER

NOTE:
IT IS NOT ANTICIPATED THAT THE EARTH SHOULDERS WILL NEED REGRADING FOLLOWING PAVING OPERATIONS. IF HOWEVER, THE DISTANCE BETWEEN THE PAVEMENT AND THE EXISTING GROUND EXCEEDS 1-1/2" AT PAVEMENT EDGE, THE CONTRACTOR SHALL ADD OR REMOVE MATERIAL AS REQUIRED TO SHAPE THE EARTH SHOULDERS TO CONFORM TO THE EARTH SHOULDER DETAIL. THE CONTRACTOR WILL REGRADE, SEED AND FERTILIZE THE DISTURBED EARTH SHOULDER. FERTILIZING AND SEEDING SHALL BE ACCOMPLISHED IN ACCORDANCE TO SPECIFICATION ITEM AR901510.

NO ADDITIONAL PAYMENT FOR THE GRADING AND SEEDING ITEM WILL BE MADE TO THE CONTRACTOR. PAYMENT FOR THE WORK SHALL BE INCLUDED IN THE BID AMOUNT PER TON FOR THE BITUMINOUS SURFACE COURSE.

IN ADDITION, ANY TURF AREAS OUTSIDE THE PROJECT LIMITS DISTURBED BY THE CONTRACTOR WILL BE RESHAPED, FERTILIZED AND SEEDING ACCORDING TO THE ABOVE PARAGRAPH.



DECATUR, ILLINOIS

HEI Project No. 08A0099D.0800
 Filename: R-521TYP.DWG
 Scale: AS SHOWN
 Date: 04/17/09

LAYOUT	MLH	01/23/09
DRAWN	MLH	01/26/09
REVIEWED	RAW	01/30/09



© Copyright Hanson Professional Services Inc. 2009
HANSON Professional Services Inc.
 1525 South Sixth Street
 Springfield, Illinois 62703-2886
 www.hanson-hs.com
 Offices Nationwide

RECONSTRUCT 960 FEET
 OF RUNWAY 6-24

EXISTING AND PROPOSED
 TYPICAL SECTIONS

BY	
REVISION	
DATE	

ILL. PROJ.: DEC-3911 A.I.P. PROJ.: 3-17-0033-2