

THE LOCATION, SIZE AND TYPE OF MATERIAL OF EXISTING UNDERGROUND UTILITIES INDICATED ON THE PLANS IS NOT REPRESENTED AS BEING ACCURATE, SUFFICIENT OR COMPLETE. IT SHALL BE THE CONTRACTOR'S RESPONSIBILITY TO DETERMINE THE ACTUAL LOCATION OF ALL SUCH FACILITIES, INCLUDING SERVICE CONNECTIONS TO UNDERGROUND UTILITIES. PRIOR TO CONSTRUCTION, THE CONTRACTOR SHALL NOTIFY THE UTILITY COMPANIES OF HIS OPERATIONAL PLANS AND SHALL OBTAIN FROM THE RESPECTIVE UTILITY COMPANIES DETAILED INFORMATION AND ASSISTANCE RELATIVE TO THE LOCATION OF THEIR FACILITIES AND THE WORKING SCHEDULE OF THE COMPANIES FOR REMOVAL OR ADJUSTMENT WHERE REQUIRED. IN THE EVENT AN UNEXPECTED UTILITY INTERFERENCE IS ENCOUNTERED DURING CONSTRUCTION, THE CONTRACTOR SHALL IMMEDIATELY NOTIFY THE UTILITY COMPANY OF JURISDICTION. THE ENGINEER SHALL ALSO BE IMMEDIATELY NOTIFIED. ANY SUCH MAINS AND SERVICES SHALL BE RESTORED TO SERVICE AT ONCE AND PAID FOR BY THE CONTRACTOR AT NO ADDITIONAL COST TO THE CONTRACT.

CALL J.U.L.I.E. AT 1-800-892-0123 FOR UTILITY INFORMATION.

EROSION CONTROL

ALL PROPOSED EROSION CONTROL MEASURES SHALL BE COMPLETED AS DETAILED ON THIS EROSION CONTROL PLAN AND IN ACCORDANCE WITH THE SPECIFICATIONS.

EROSION CONTROL MEASURES ARE GOVERNED BY THE ILLINOIS ENVIRONMENTAL PROTECTION AGENCY'S STANDARDS AND SPECIFICATIONS FOR SOIL EROSIONS AND SPECIFICATION FOR SOIL EROSIONS AND SEDIMENT CONTROL.

EROSION CONTROL FENCE SHALL BE REMOVED WHEN IT HAS SERVED ITS USEFULNESS SO AS NOT TO BLOCK OR IMPEDE STORM WATER DRAINAGE.

COST OF REMOVAL AND REPLACEMENT SHALL BE INCLUDED IN THE UNIT PRICE FOR ITEM AR156510 SILT FENCE.

EROSION CONTROL BLANKET NOTES

AN EROSION CONTROL MATERIAL (EXCELSIOR BLANKET) WILL BE INSTALLED AT THE LOCATIONS SHOWN ON THESE CONSTRUCTION PLANS AND IN ACCORDANCE WITH THE SPECIAL PROVISIONS.

THIS ITEM OF WORK SHALL BE PAID FOR UNDER ITEM AR156531 EROSION CONTROL BLANKET, PER SQUARE YARD.

REVISION	DATE

EDGAR COUNTY AIRPORT
PARIS, ILLINOIS

A.I.P. PROJ.: 3-17-0077-811
IL PROJ.: PRC-3689

ILL. PROJECT No. 0840209 0800 Elevation R-1715WP.DWG Scale 1"=30' Date 04/17/09	MLH 03/06/09 MLH 03/06/09 JDW 03/18/09
LAYOUT	
DRAWN	
REVIEWED	

HANSON
 Hanson Professional Services Inc. 2009
 1525 South Skelm Street
 Springfield, Illinois 62703-2886
 www.hansonps.com
 Offices Nationwide

REMOVE AND RECONSTRUCT
T-HANGAR TAXIWAYS

PROPOSED STORMWATER
POLLUTION PREVENTION PLAN

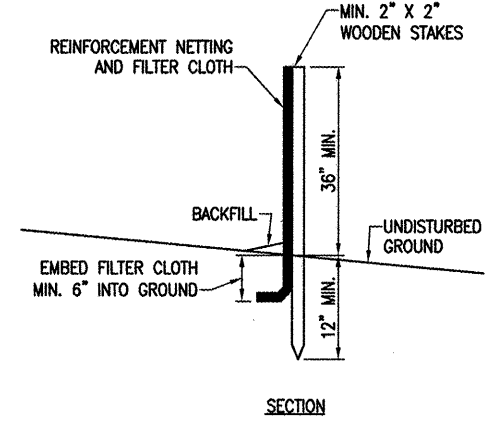
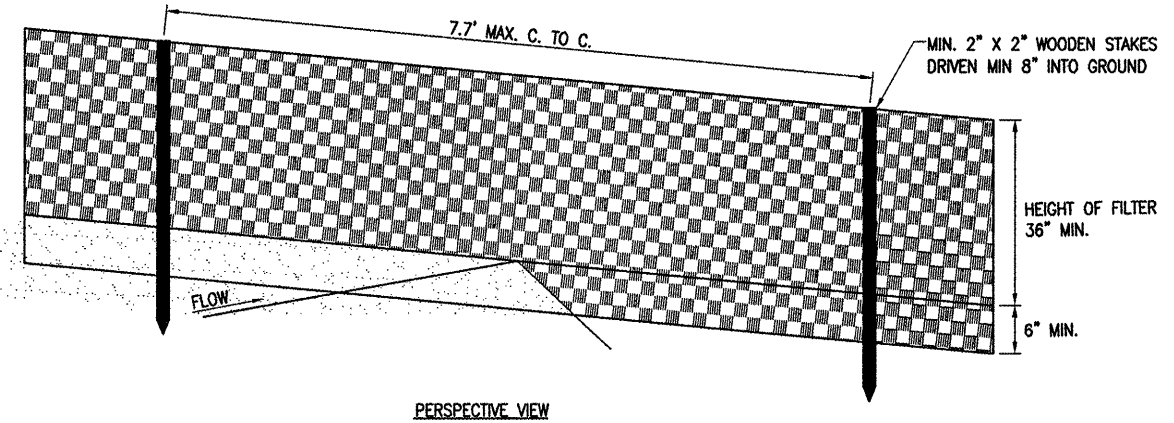

LEGEND

- EXISTING PAVEMENT
- PROPOSED IMPROVEMENTS
- EXISTING BUILDINGS
- EXISTING FENCE
- PROPOSED PERIMETER SILT FENCE

30 0 30 60