

F.A.I. RTE.	SECTION	COUNTY	TOTAL SHEETS	SHEET NO.
59	•	WILL	608	296
STA.		TO STA.		
FED. ROAD DIST. NO. 1 ILLINOIS FED. AID PROJECT				
* (26, 26HB-1 & 114) R-2				
CONTRACT NO. 60363				

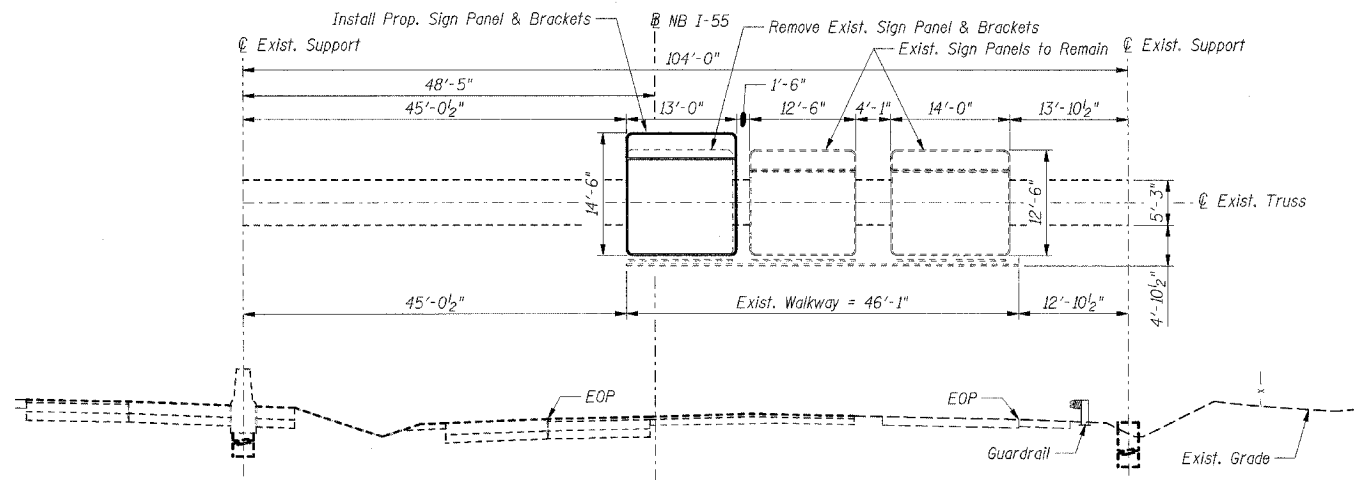

**IS099I055RS49.90**  
**STA. 33+80**  
**I-55 NB LOOKING NORTH**

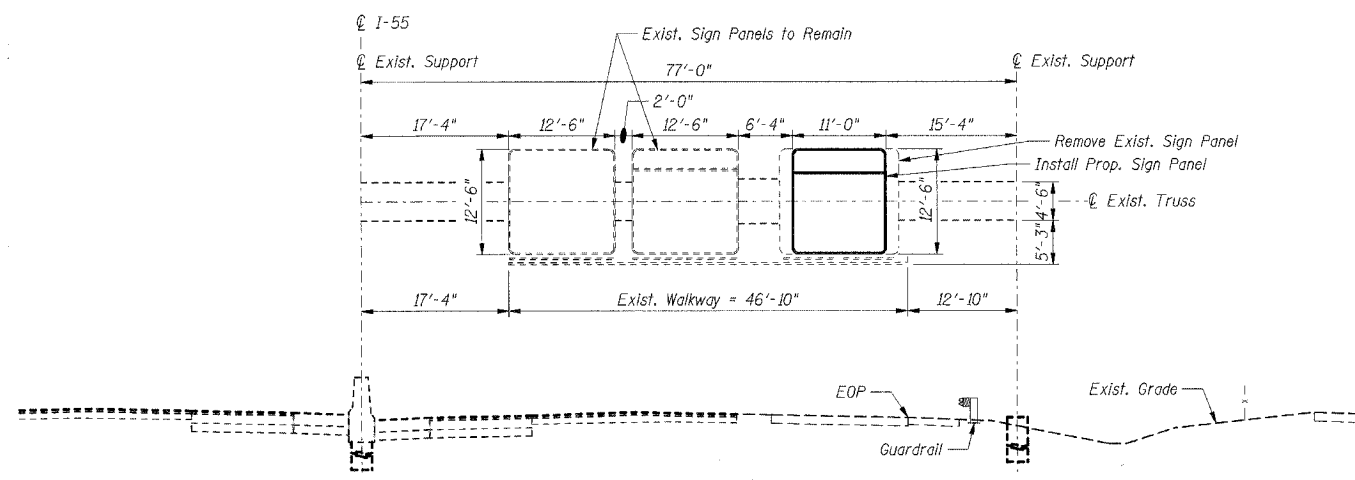

**IS099I055L250.67**  
**STA. 74+25**  
**I-55 SB LOOKING SOUTH**

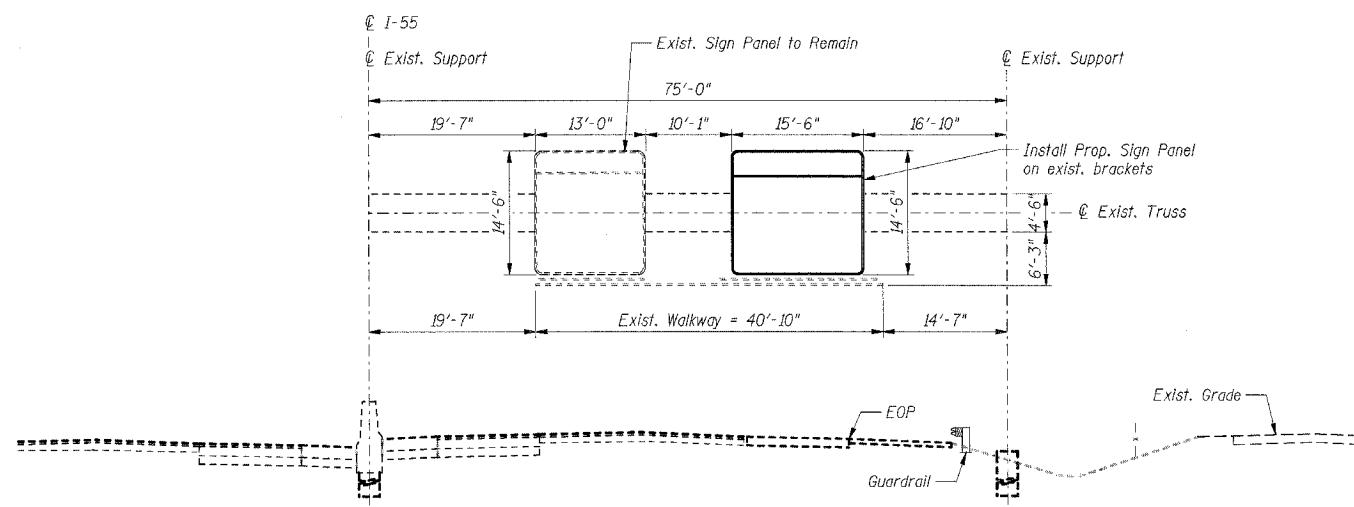

**IS099I055R251.02**  
**STA. 92+32**  
**I-55 NB LOOKING NORTH**

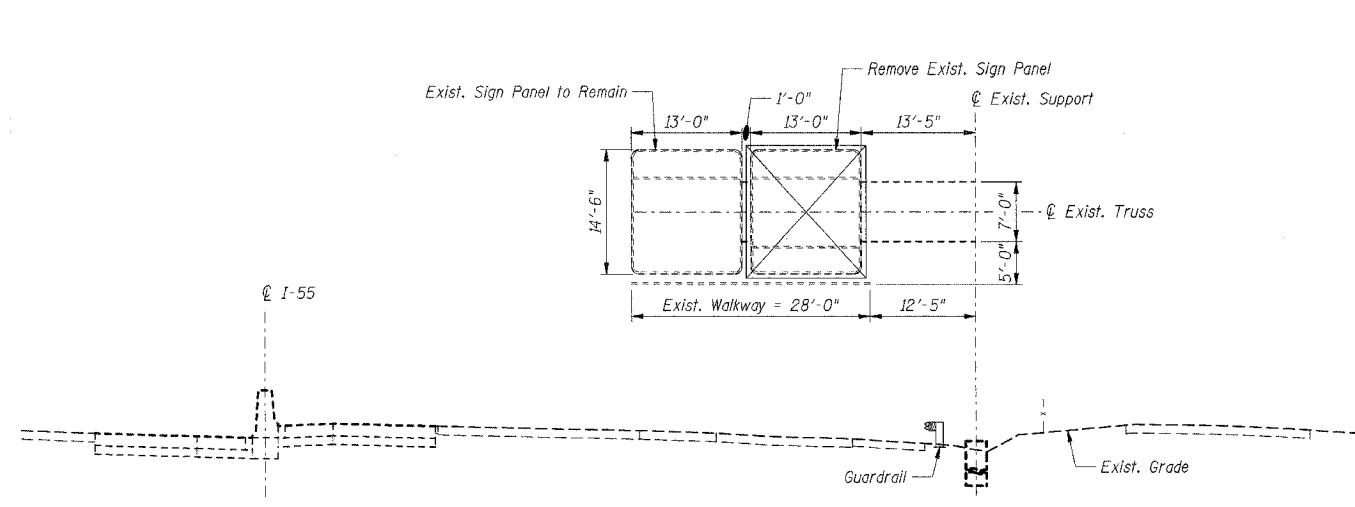

**IC099I055R251.56**  
**STA. 121+53**  
**I-55 NB LOOKING NORTH**

\\TERRA\HDD\... \SGN002TE.DGN, ... \SGN002TE.DGN, ... \SGN002TE.DGN  
 3-05-2008, 12:26:30  
 T:\DOCUMENT\1932796\STRUCT\VDGN\SGN002TE.DGN  
 color Table: K:\STANDARD\TEMP\DATA\COLORTABLE.TBL  
 color Table: N/A

REVISIONS	
NAME	DATE

ILLINOIS DEPARTMENT OF TRANSPORTATION  
 FAI 55 AT FAP 338 ILLINOIS ROUTE 59  
 SECTION: (26, 26HB-1 & 114) R-2

SIGNING ELEVATIONS I

DRAWN BY: MDB  
 CHECKED BY:

DATE: 03/14/08

**TENG**  
 TENG & ASSOCIATES, INC.  
 ENGINEERS/PLANNERS  
 305 N. MICHIGAN AVE. CHICAGO, IL 60610  
 TELEPHONE: 312.664.6000