

EXISTING TYPICAL SECTION
ILL 53 (BOLINGBROOK DRIVE)
STA. 140+66 TO STA. 142+15

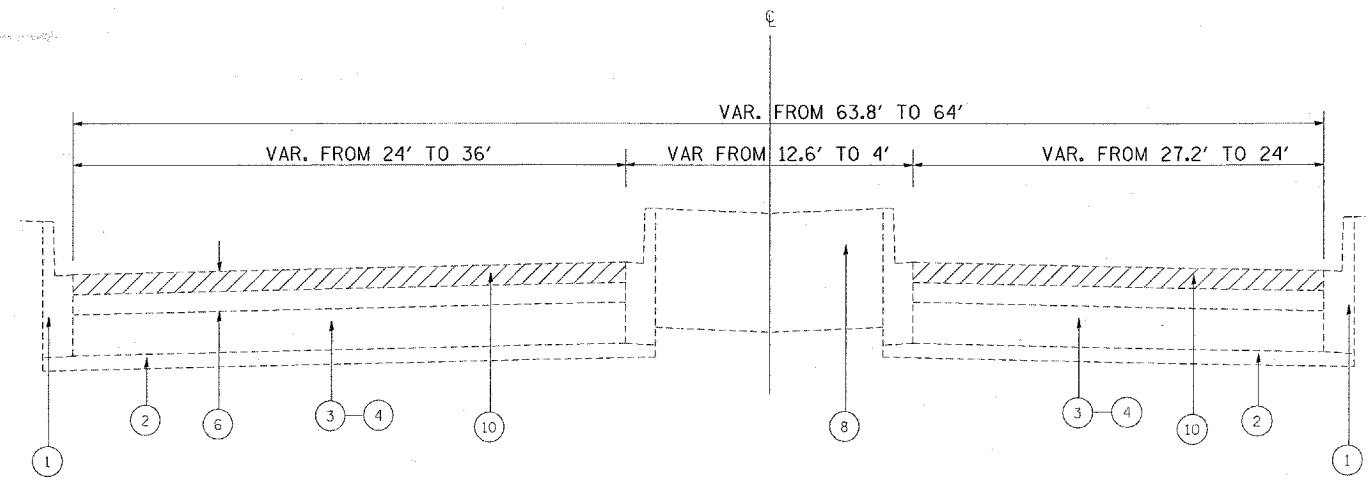

EXISTING TYPICAL SECTION
ILL 53 (BOLINGBROOK DRIVE)
STA. 148+67 TO STA. 151+49

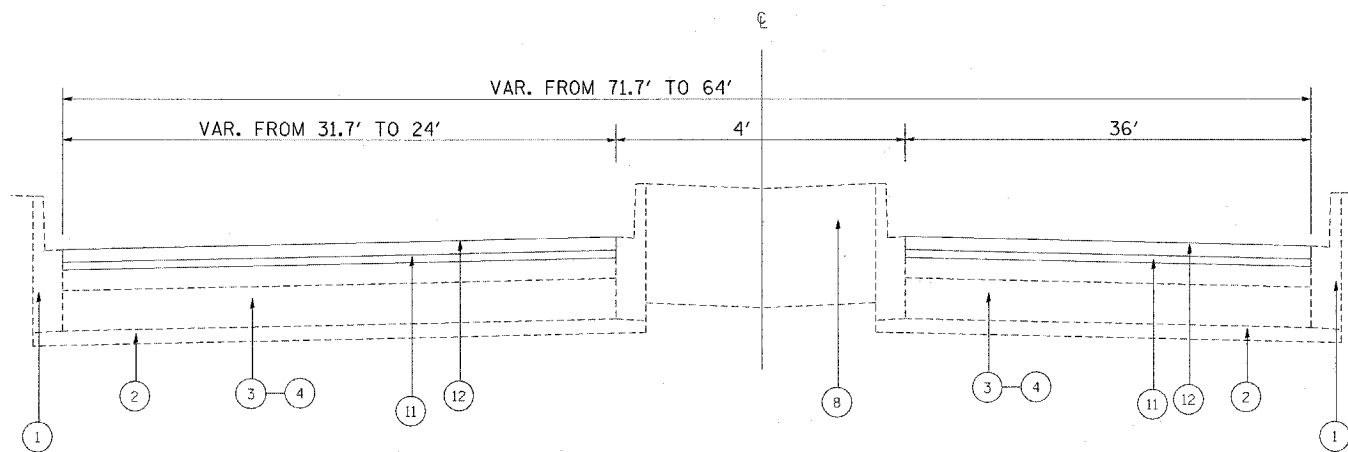

PROPOSED TYPICAL SECTION
ILL 53 (BOLINGBROOK DRIVE)
STA. 140+66 TO STA. 142+15

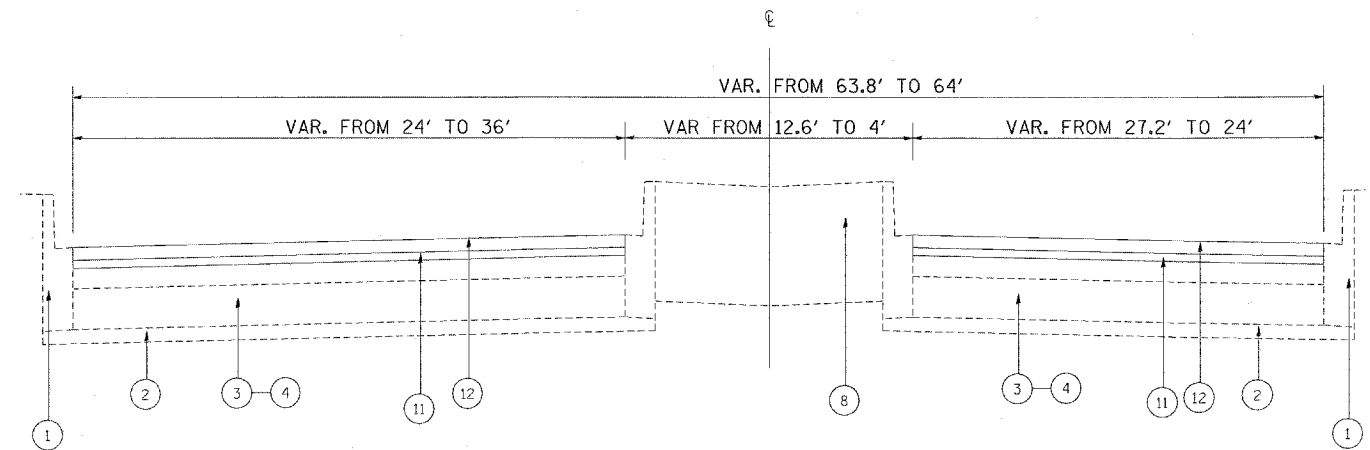

PROPOSED TYPICAL SECTION
ILL 53 (BOLINGBROOK DRIVE)
STA. 148+67 TO STA. 151+49

LEGEND

- | | |
|-------------------------------------------------------------------------------------|--------------------------------------------------------------------------------|
| ① EXISTING COMBINATION CONCRETE CURB AND GUTTER | ⑧ EXISTING P.C. CONCRETE BARRIER MEDIAN (PLANTED MEDIAN) |
| ② EXISTING SUB-GRADE | ** ⑨ EXISTING ASPHALT MOUNTABLE MEDIAN |
| ③ EXISTING HOT-MIX ASPHALT BASE COURSE 10"
(NOTE: BETWEEN STA. 117+49 TO 272+53) | ⑩ PROPOSED HOT-MIX ASPHALT SURFACE REMOVAL, 2 1/2" |
| ④ EXISTING PCC BASE COURSE 9"
(NOTE: BETWEEN 46+98 TO 100+96) | ⑪ PROPOSED POLYMERIZED LEVELING BINDER (MACHINE METHOD),
IL-4.75, N50, 3/4" |
| ⑤ EXISTING PCC BASE COURSE 10" | ⑫ PROPOSED POLYMERIZED HOT-MIX ASPHALT SURFACE COURSE,
MIX "F", N90, 1 3/4" |
| ⑥ EXISTING HOT-MIX ASPHALT OVERLAY | |
| ⑦ EXISTING HMA SHOULDER 8" | |

FILE NAME = c:\projects\dl16908\dl16908.dgn	USER NAME = abrough	DESIGNED -	REVISED -	STATE OF ILLINOIS DEPARTMENT OF TRANSPORTATION	ILL 53 (BOLINGBROOK DRIVE) TYPICAL SECTIONS	F.A.P. RTE. 870	SECTION 534 RS-3	COUNTY WILL	TOTAL SHEETS 41	SHEET NO. 7		
PLT SCALE = 50,0000' / IN.	CHECKED -	REVISED -	REVISED -			SCALE:	SHEET NO. OF SHEETS	STA. 17+49 TO STA. 172+53	FED. ROAD DIST. NO. 1 ILLINOIS FED. AID PROJECT			
PLT DATE = 2/20/2008	DATE -	REVISED -	REVISED -			CONTRACT NO. 60E08						