

F.A.P. RTE.	SECTION	COUNTY	TOTAL SHEETS	SHEET NO.
344	3034 RS-4	COOK	21	1
FED. ROAD DIST. NO. 1	ILLINOIS	CONTRACT NO. 60E30		

STATE OF ILLINOIS
DEPARTMENT OF TRANSPORTATION
DIVISION OF HIGHWAYS

PROPOSED
HIGHWAY PLANS
FAP ROUTE 344 (127TH STREET)
KOSTNER AVENUE TO CRAWFORD AVENUE
SECTION 3034 RS-4
PROJECT: NHF-0344(047)
RESURFACING (3P)
COOK COUNTY
C-91-351-08

FOR INDEX OF SHEETS, SEE SHEET NO. 2

PROJECT LOCATED
THE VILLAGE OF
IN ALSIP

2006 ADT = 32,700 VEHICLES PER DAY
SPEED LIMIT = 40 MPH

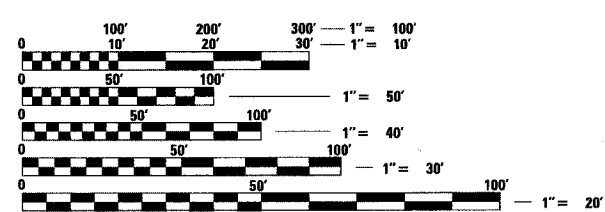

FULL SIZE PLANS HAVE BEEN PREPARED USING STANDARD ENGINEERING SCALES. REDUCED SIZED PLANS WILL NOT CONFORM TO STANDARD SCALES. IN MAKING MEASUREMENTS ON REDUCED PLANS, THE ABOVE SCALES MAY BE USED.

J.U.L.I.E.
JOINT UTILITY LOCATION INFORMATION FOR EXCAVATION
1-800-892-0123
OR 811

PROJECT ENGINEER: MICHELLE AQUINO (847) 705-4606
PROJECT MANAGER: LONG TRAN (847) 705-4232

CONTRACT NO. 60E30

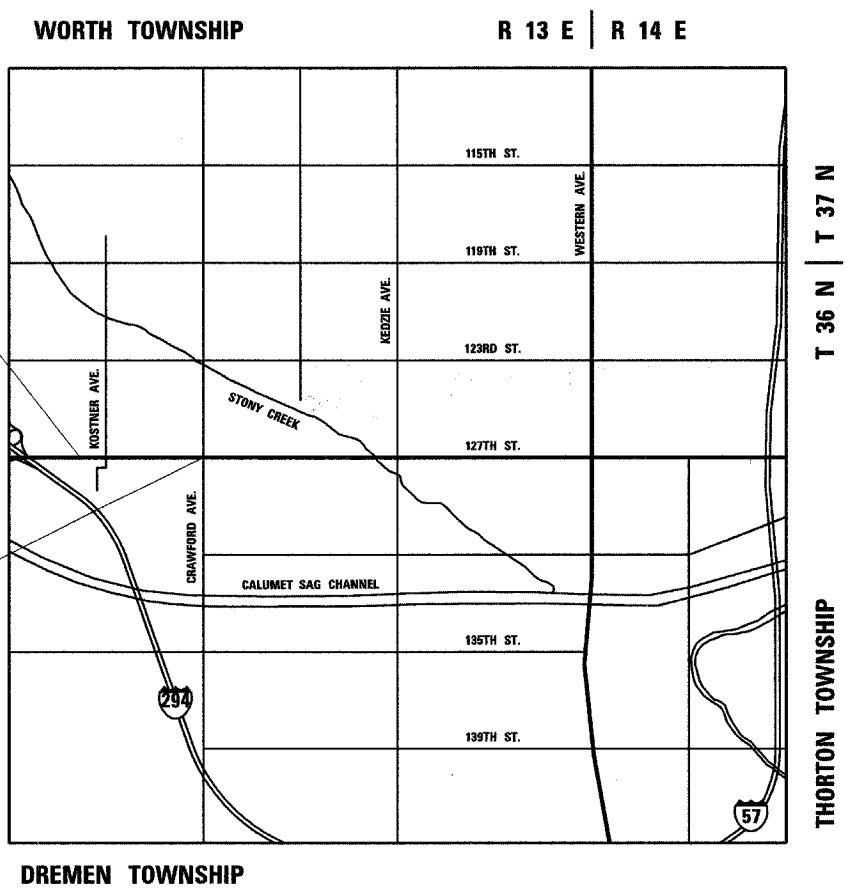

PROJECT BEGINS
STA 8+00

PROJECT ENDS
STA 40+47

GROSS & NET LENGTH OF PROJECT = 3247 FT = 0.61 MILES

LOCATION MAP
NOT TO SCALE

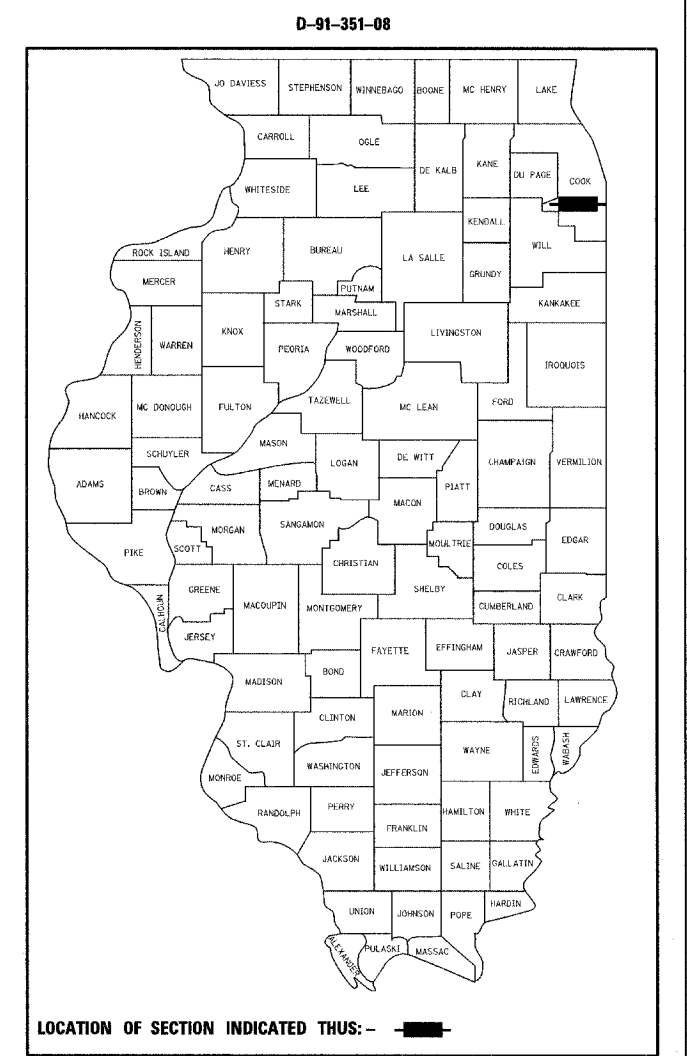

STATE OF ILLINOIS
DEPARTMENT OF TRANSPORTATION
DIVISION OF HIGHWAYS

SUBMITTED MARCH 31, 2008
Diana M. O'Keefe
DEPUTY DIRECTOR OF HIGHWAYS, REGION ENGINEER

May 9, 2008
Eric E. Harsh
ENGINEER OF DESIGN AND ENVIRONMENT

May 9, 2008
Christine M. Reed
DIRECTOR OF HIGHWAYS, CHIEF ENGINEER

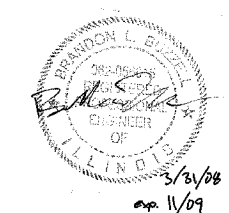

rjngroup
 Excellence through Ownership
 200 West Front Street
 Wheaton, IL 60187

PRINTED BY THE AUTHORITY
OF THE STATE OF ILLINOIS

INDEX OF SHEETS

SHEET NO.	DESCRIPTION
1.	TITLE SHEET
2.	INDEX OF SHEETS, STATE STANDARDS, GENERAL NOTES
3.	SUMMARY OF QUANTITIES
4.	EXISTING TYPICAL SECTIONS
5.	PROPOSED TYPICAL SECTIONS
6-7.	ROADWAY AND PAVEMENT MARKING PLAN
8-9.	LOOP DETECTOR PLANS
10.	DETAILS FOR FRAMES AND LIDS ADJUSTMENT WITH MILLING
11.	PAVEMENT PATCHING FOR HMA SURFACED PAVEMENT
12.	CURB OR CURB AND GUTTER REMOVAL AND REPLACEMENT
13.	BUTT JOINT AND HMA TAPER DETAILS
14.	TRAFFIC CONTROL AND PROTECTION FOR SIDE ROADS, INTERSECTIONS, AND DRIVEWAYS
15.	TYPICAL APPLICATIONS RAISED REFLECTIVE PAVEMENT MARKERS (SNOW-PLOW RESISTANT)
16.	DISTRICT ONE TYPICAL PAVEMENT MARKINGS
17.	TRAFFIC CONTROL AND PROTECTION AT TURN BAYS (TO REMAIN OPEN TO TRAFFIC)
18.	PAVEMENT MARKING LETTERS AND SYMBOLS FOR TRAFFIC STAGING
19.	ARTERIAL ROAD INFORMATION SIGN
20.	DRIVEWAY ENTRANCE SIGNING
21.	DISTRICT 1 DETECTOR LOOP INSTALLATION DETAILS FOR ROADWAY RESURFACING

STATE STANDARDS

STANDARD NO.	DESCRIPTION
000001-05	STANDARD SYMBOLS, ABBREVIATIONS AND PATTERNS
442201-03	CLASS C AND D PATCHES
604061-01	FRAME AND GRATE, TYPE 12
701606-05	URBAN LANE CLOSURE, 2W WITH MOUNTABLE MEDIAN
701701-05	URBAN LANE CLOSURE, MULTILANE INTERSECTION
701901	TRAFFIC CONTROL DEVICES

GENERAL NOTES

- BEFORE STARTING ANY EXCAVATION, THE CONTRACTOR SHALL CALL *J.U.L.I.E.* AT (800)892-0123 FOR FIELD LOCATIONS OF BURIED ELECTRIC, TELEPHONE AND GAS UTILITIES. (48 HOUR NOTIFICATION IS REQUIRED.)
- ALL PAVEMENT MARKING SHALL BE PLACED THROUGHOUT THE PROJECT ACCORDING TO DISTRICT 1 TYPICAL PAVEMENT MARKING.
- ALL HMA PAVEMENT PATCHING SHALL BE CLASS D.
- THE CONTRACTOR WILL NOT BE ALLOWED TO SET UP A YARD OR FIELD OFFICE ON STATE PROPERTY WITHOUT WRITTEN PERMISSION FROM THE DEPARTMENT.
- ANY PAVEMENT MARKINGS AND RAISED REFLECTIVE PAVEMENT MARKERS OBLITERATED BY MILLING AND RESURFACING OPERATIONS ON SIDE STREETS AND ENTRANCES SHALL BE REPLACED AND PAID FOR IN KIND.
- BEFORE BEGINNING ANY WORK, THE CONTRACTOR SHALL RETAIN AND RECORD (FOR FUTURE REFERENCES), ALL EXISTING PAVEMENT MARKING LINES IN ORDER THAT THESE LOCATIONS CAN BE RE-ESTABLISHED FOR STRIPING. EXACT LOCATIONS OF ALL STRIPING SHALL BE AS DIRECTED BY THE ENGINEER.
- ALL PAVEMENT PATCHING LOCATIONS WILL BE DETERMINED IN THE FIELD BY THE ENGINEER.
- DRAINAGE ADJUSTMENT OR RECONSTRUCTION LOCATIONS WILL BE DETERMINED IN THE FIELD BY THE ENGINEER.
- LOCATIONS FOR TYPE 12 FRAMES AND GRATES TO REPLACE EXISTING NON-BICYCLE-SAFE GRATES WILL BE DETERMINED IN THE FIELD BY THE ENGINEER.
- FRAMES AND GRATES ADJUSTMENT OF PRIVATE UTILITIES WITHIN THE LIMITS OF THE IMPROVEMENTS SHALL BE DONE BY THEIR RESPECTIVE OWNERS AND ARE NOT PART OF THIS CONTRACT.
- THE RESIDENT ENGINEER SHALL CONTACT THE DISTRICT ONE TRAFFIC CONTROL SUPERVISOR AT (847) 705-4470 A MINIMUM OF 72 HOURS PRIOR TO THE PLACEMENT OF ANY TEMPORARY TRAFFIC CONTROL DEVICES.
- THE ENGINEER SHALL CONTACT MS. PATRICE HARRIS, THE TRAFFIC FIELD ENGINEER, @ 708-597-9800 TWO (2) WEEKS PRIOR TO THE START OF THIS PROJECT SO THAT EXACT STATIONING OF NO PASSING ZONES AND OTHER PERMANENT PAVEMENT MARKINGS MAY BE ESTABLISHED.
- THE CONTRACTOR SHALL BE REQUIRED TO PROVIDE ACCESS TO ABUTTING PROPERTY AT ALL TIMES DURING THE CONSTRUCTION OF THIS PROJECT.
- EXISTING BROKEN FRAMES AND LIDS, OR NON-BICYCLE-SAFE GRATES SHALL BE REMOVED AND DISPOSED OF BY THE CONTRACTOR AND SHALL BE REPLACED AS DIRECTED BY THE ENGINEER. REPLACEMENT FRAMES AND GRATES OR LIDS WILL BE PAID FOR IN ACCORDANCE WITH ARTICLE 109.04 OF THE STANDARD SPECIFICATIONS, UNLESS A SEPARATE PAY ITEM HAS BEEN PROVIDED.
- DO NOT SCALE PLANS FOR CONSTRUCTION DIMENSIONS.
- DOUBLE LANE MARKERS ARE TO BE USED AS SHOWN ON THE DISTRICT ONE DETAIL FOR TYPICAL APPLICATION OF RAISED REFLECTIVE PAVEMENT MARKERS (SNOW-PLOW RESISTANT) SHOWN IN THE PLANS.
- WHEN ARTIFICIAL LIGHTING IS USED IN NIGHT OPERATIONS THE CONTRACTOR SHALL EXERCISE THE UTMOST PRECAUTIONS IN PREVENTING ADVERSE VISIBILITY TO THE MOTORING PUBLIC AND ADJOINING RESIDENTIAL AREAS.
- WHEN MILLED PAVEMENT IS OPEN TO TRAFFIC THE MAXIMUM GRADE DIFFERENTIAL BETWEEN PASSES OF THE MILLING MACHINE SHALL NOT EXCEED 1/2 INCHES (40 MM) WHERE THE SPEED LIMIT IS 45 MPH (80 KM/H) OR LESS AND 1 INCH (25 MM) WHERE THE SPEED LIMIT IS GREATER THAN 45 MPH (80 KM/H). WITH WRITTEN APPROVAL FROM THE ENGINEER, A MAXIMUM GRADE DIFFERENTIAL OF 3 INCHES (75 MM) MAY BE ALLOWED IF THE EDGE OF THE MILLING IS SLOPED A MINIMUM 1:3 (V:H)
- BUTT JOINTS WILL BE INSTALLED AT THE ENDS OF ALL RESURFACING (WHERE RESURFACING MEETS EXISTING PAVEMENT), IN ACCORDANCE WITH THE "BUTT JOINT AND HOT-MIX ASPHALT TAPER DETAILS" SHEET INCLUDED IN THE PLANS, UNLESS OTHERWISE SPECIFIED.
- IT SHALL BE THE CONTRACTOR'S RESPONSIBILITY TO VERIFY ALL DIMENSIONS AND CONDITIONS EXISTING IN THE FIELD PRIOR TO CONSTRUCTION AND ORDERING OF MATERIALS.
- THE CONTRACTOR SHALL COORDINATE CONSTRUCTION ACTIVITIES WITH UTILITY COMPANIES, AND WITH THE VILLAGE OF ALSIP.

PLOT DATE = 4/18/2008
 FILE NAME = K:\11225505\Civil\Sheet\11225505_NOTES.dgn
 USER NAME = jh
 MODEL = Defaul



Excellence through Ownership

200 West Front Street
 Wheaton, IL 60187

DESIGNED -	WJV	REVISED -	
DRAWN -	WJV	REVISED -	
CHECKED -	BLB	REVISED -	
DATE -	3/28/08	REVISED -	

STATE OF ILLINOIS
 DEPARTMENT OF TRANSPORTATION

127th ST. (KOSTNER AVE. - CRAWFORD AVE.)
 INDEX OF SHEETS, STATE STANDARDS, AND GENERAL NOTES

SCALE: SHEET NO. OF SHEETS STA. TO STA.

F.A.P. RTE.	SECTION	COUNTY	TOTAL SHEETS	SHEET NO.
344	3034 RS-4	COOK	21	2
				CONTRACT NO. 60E30

FED. ROAD DIST. NO. 1 [ILLINOIS] FED. AID PROJECT

80% FED.
20% STATE

SUMMARY OF QUANTITIES			URBAN TOTAL QUANTITY	CONSTRUCTION TYPE CODE
CODE NO.	ITEM DESCRIPTION	UNIT	1000-2A	
40600200	BITUMINOUS MATERIALS (PRIME COAT)	TON	10.9	10.9
40600300	AGGREGATE (PRIME COAT)	TON	54	54
40600400	MIXTURE FOR CRACKS, JOINTS, AND FLANGEWAYS	TON	107	107
40600895	CONSTRUCTING TEST STRIP	EACH	1	1
40600982	HOT-MIX ASPHALT SURFACE REMOVAL - BUTT JOINT	SQ YD	68	68
40601005	HOT-MIX ASPHALT REPLACEMENT OVER PATCHES	TON	70	70
40603595	POLYMERIZED HOT-MIX ASPHALT SURFACE COURSE, MIX "F", N90	TON	1,780	1,780
44001700	COMBINATION CONCRETE CURB AND GUTTER REMOVAL AND REPLACEMENT	FOOT	300	300
44000159	HOT-MIX ASPHALT SURFACE REMOVAL, 2 1/2"	SQ YD	18,150	18,150
44002212	HOT-MIX ASPHALT REMOVAL OVER PATCHES, 3"	SQ YD	417	417
44201753	CLASS D PATCHES, TYPE II, 9 INCH	SQ YD	219	219
44201757	CLASS D PATCHES, TYPE III, 9 INCH	SQ YD	110	110
44201759	CLASS D PATCHES, TYPE IV, 9 INCH	SQ YD	48	48
60300105	FRAMES AND LIDS TO BE ADJUSTED	EACH	4	4
60300310	FRAMES AND LIDS TO BE ADJUSTED (SPECIAL)	EACH	36	36
60404900	FRAMES AND GRATES, TYPE 12	EACH	17	17
67000400	ENGINEER'S FIELD OFFICE, TYPE A	CAL MO	6	6
67100100	MOBILIZATION	L SUM	1	1
70102625	TRAFFIC CONTROL AND PROTECTION, STANDARD 701606	L SUM	1	1
70102635	TRAFFIC CONTROL AND PROTECTION, STANDARD 701701	L SUM	1	1
70300100	SHORT-TERM PAVEMENT MARKING	FOOT	3,096	3,096
70300210	TEMPORARY PAVEMENT MARKING - LETTERS AND SYMBOLS	SQ FT	110	110
70300220	TEMPORARY PAVEMENT MARKING - LINE 4"	FOOT	10,430	10,430
70300240	TEMPORARY PAVEMENT MARKING - LINE 6"	FOOT	638	638
70300260	TEMPORARY PAVEMENT MARKING - LINE 12"	FOOT	275	275
70300280	TEMPORARY PAVEMENT MARKING - LINE 24"	FOOT	81	81
70301000	WORK ZONE PAVEMENT MARKING REMOVAL	SQ FT	1,032	1,032
* 78000100	THERMOPLASTIC PAVEMENT MARKING - LETTERS AND SYMBOLS	SQ FT	110	110
* 78000200	THERMOPLASTIC PAVEMENT MARKING - LINE 4"	FOOT	10,430	10,430
* 78000400	THERMOPLASTIC PAVEMENT MARKING - LINE 6"	FOOT	638	638
* 78000600	THERMOPLASTIC PAVEMENT MARKING - LINE 12"	FOOT	275	275
* 78000650	THERMOPLASTIC PAVEMENT MARKING - LINE 24"	FOOT	81	81
* 78100100	RAISED REFLECTIVE PAVEMENT MARKER	EACH	283	283
78300200	RAISED REFLECTIVE PAVEMENT MARKER REMOVAL	EACH	283	283
* 88600600	DETECTOR LOOP REPLACEMENT	FOOT	472	472
X0322256	TEMPORARY INFORMATION SIGNING	SQ FT	280.6	280.6
X4067107	POLYMERIZED LEVELING BINDER (MACHINE METHOD), IL 4.75, N50	TON	955	955
-Z0076600-	-TRAINEES-	-HOUR-		

* SPECIALTY ITEM

PLOT DATE = 4/3/2008
 FILE NAME = K:\1122505\G:\1\Sheets\1122505_500.dgn
 USER NAME = bhuzell
 MODEL = Default



200 West Front Street
 Wheaton, IL 60187

DESIGNED -	REVISED -
DRAWN -	REVISED -
CHECKED -	REVISED -
DATE -	REVISED -

STATE OF ILLINOIS
 DEPARTMENT OF TRANSPORTATION

127th ST. (KOSTNER AVE. - CRAWFORD AVE.)
 SUMMARY OF QUANTITIES

SCALE: SHEET NO. OF SHEETS STA. TO STA.

F.A.P. RTE.	SECTION	COUNTY	TOTAL SHEETS	SHEET NO.
344	3034 RS-4	COOK	21	3
CONTRACT NO. 60E30				
FED. ROAD DIST. NO. 1 ILLINOIS FED. AID PROJECT				

Rev.

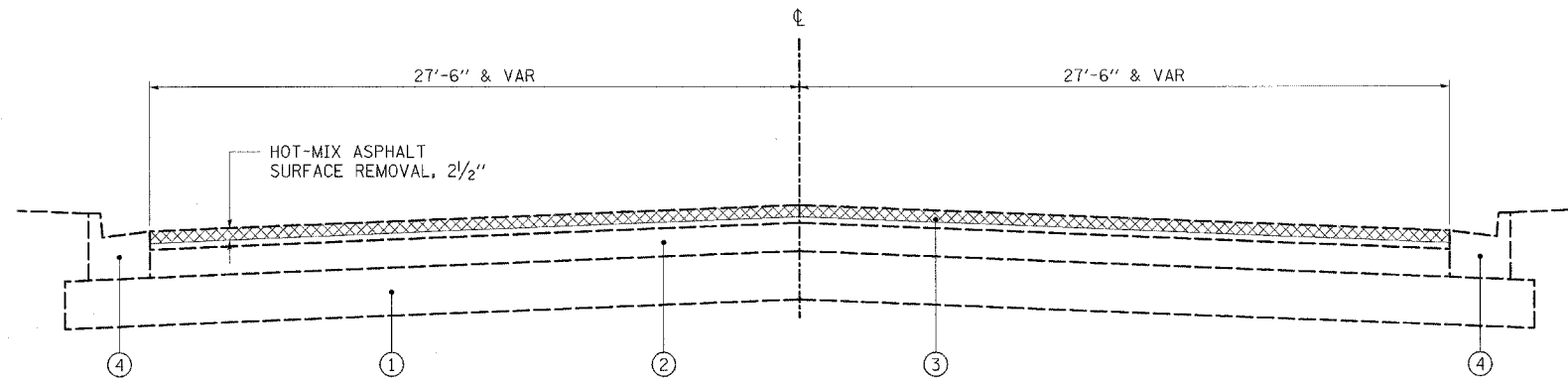

EXISTING TYPICAL SECTION 127th STREET

STA 8+00 TO STA 20+25

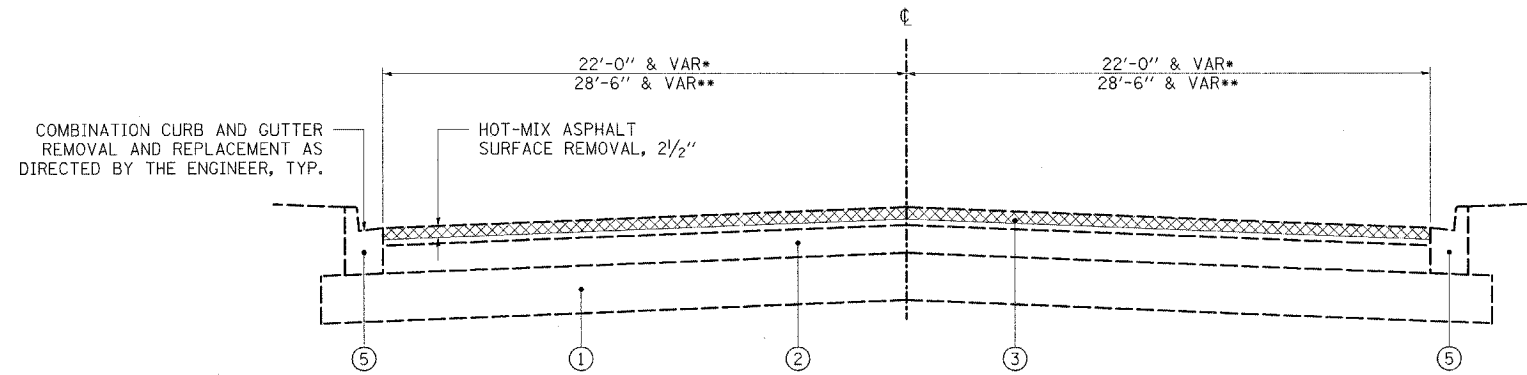

EXISTING TYPICAL SECTION 127th STREET

*STA 20+25 TO STA 35+90
**STA 35+90 TO STA 40+35

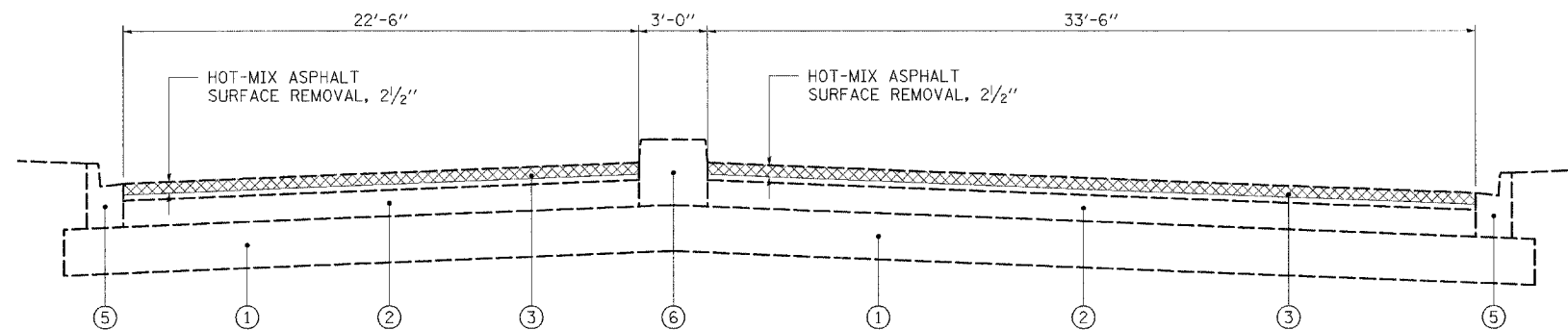

EXISTING TYPICAL SECTION 127th STREET

STA 40+35 TO STA 40+47

LEGEND

- ① EXISTING AGGREGATE BASE COURSE
- ② EXISTING PCC PAVEMENT (ASSUMED 10")
- ③ EXISTING HOT-MIX ASPHALT PAVEMENT, 3" (BEFORE SURFACE REMOVAL)
- ④ EXISTING COMBINATION CURB AND GUTTER, TYPE B-6.24
- ⑤ EXISTING COMBINATION CURB AND GUTTER, TYPE B-6.12
- ⑥ EXISTING MEDIAN
- ⑦ PROPOSED POLYMERIZED LEVELING BINDER (MACHINE METHOD), IL-4.75, N50, 3/4"
- ⑧ PROPOSED POLYMERIZED HOT-MIX ASPHALT SURFACE COURSE, "MIX F", N90, 1 3/4"

4/18/2008
 K:\11225925\cavil\eheska\11225925\EXTYPICAL.dgn
 Plot Scale = 1" = 10'-0"
 Plot Name = Section
 Model = Default

DESIGNED - LCM	REVISED -
DRAWN - LCM	REVISED -
CHECKED - BLB	REVISED -
DATE - 3/28/08	REVISED -

F.A.P. RTE. 344	SECTION 3034 RS-4	COUNTY COOK	TOTAL SHEETS 21	SHEET NO. 4
FED. ROAD DIST. NO. 1 ILLINOIS FED. AID PROJECT				

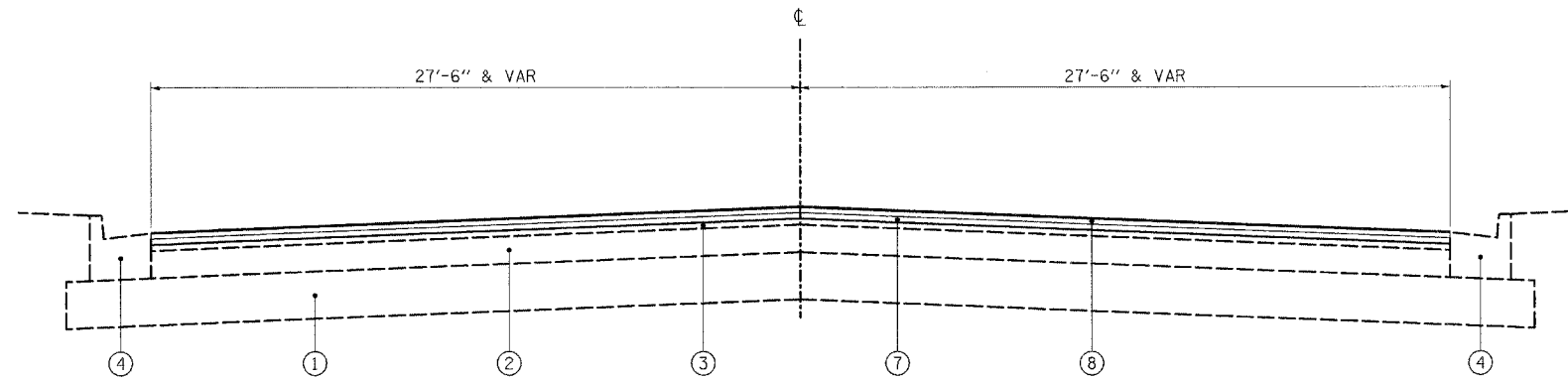

PROPOSED TYPICAL SECTION 127th STREET

STA 8+00 TO STA 20+25

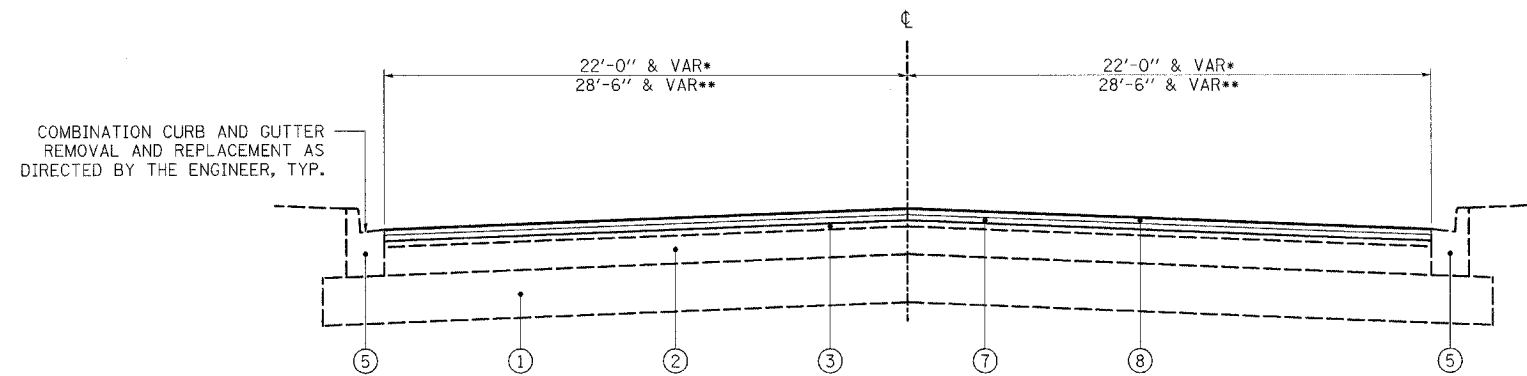

PROPOSED TYPICAL SECTION 127th STREET

*STA 20+25 TO STA 35+90
 **STA 35+90 TO STA 40+35

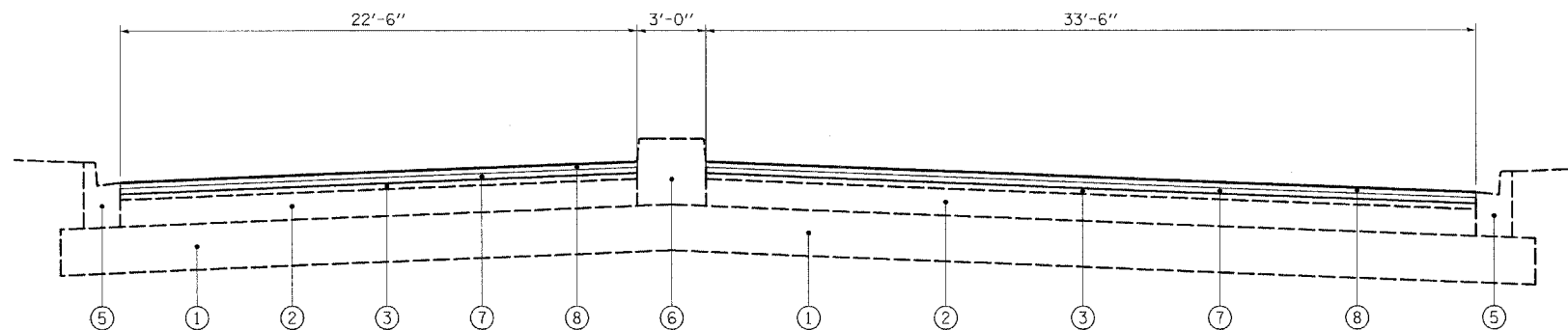

PROPOSED TYPICAL SECTION 127th STREET

STA 40+35 TO STA 40+47

HOT-MIX ASPHALT MIXTURE

MIXTURE	AC TYPE	AIR VOIDS (%)
POLYMERIZED HOT-MIX ASPHALT SURFACE COURSE, MIX "F", N90 (IL 9.5 mm)	SBS/SBR PG 70-22	4% @ 90 GYR.
POLYMERIZED LEVELING BINDER (MACHINE METHOD), IL-4.75, N50	SBS/SBR PG 76-28/-22	4% @ 50 GYR.
HMA REPLACEMENT OVER PATCHES (HMA BINDER, IL-19 mm)	PG 64-22*	4% @ 70 GYR.
CLASS D PATCH (HMA BINDER, IL-19 mm)	PG 64-22*	4% @ 70 GYR.

THE UNIT WEIGHT USED TO CALCULATE ALL HOT-MIX ASPHALT SURFACE MIXTURES IS 112 LBS/SQ YD/IN

*WHEN RAP EXCEEDS 20%, THE NEW ASPHALT BINDER IN THE MIX SHALL BE PG 58-22.

LEGEND

- ① EXISTING AGGREGATE BASE COURSE
- ② EXISTING PCC PAVEMENT (ASSUMED 10")
- ③ EXISTING HOT-MIX ASPHALT PAVEMENT, 3" (BEFORE SURFACE REMOVAL)
- ④ EXISTING COMBINATION CURB AND GUTTER, TYPE B-6.24
- ⑤ EXISTING COMBINATION CURB AND GUTTER, TYPE B-6.12
- ⑥ EXISTING MEDIAN
- ⑦ PROPOSED POLYMERIZED LEVELING BINDER (MACHINE METHOD), IL-4.75, N50, 3/4"
- ⑧ PROPOSED POLYMERIZED HOT-MIX ASPHALT SURFACE COURSE, "MIX F", N90, 1 3/4"

PLOT DATE = 4/18/2008
 FILE NAME = R:\112255805\civ1\worksheets\112255805.TYPICAL.dgn
 PLOT SCALE = 1/8"=1'-0"
 PLOT NAME = 112255805.dwg
 MODEL =



200 West Front Street
 Wheaton, IL 60187

DESIGNED - LCM	REVISED -
DRAWN - LCM	REVISED -
CHECKED - BLB	REVISED -
DATE - 3/28/08	REVISED -

STATE OF ILLINOIS
 DEPARTMENT OF TRANSPORTATION

127th ST. (KOSTNER AVE. - CRAWFORD AVE.)
 PROPOSED TYPICAL SECTIONS

SCALE: SHEET NO. OF SHEETS STA. TO STA.

F.A.P. RTE.	SECTION	COUNTY	TOTAL SHEETS	SHEET NO.
344	3034 RS-4	COOK	21	5
CONTRACT NO. 60E30				
FED. ROAD DIST. NO. 1 ILLINOIS FED. AID PROJECT				

THERMOPLASTIC PAVEMENT MARKING LEGEND

- ① 4" DOUBLE SOLID YELLOW LINE (11" C-C)
 - ② 4" WHITE LANE LINE (10' LINE, 30' SPACE)
 - ③ 6" SOLID WHITE LINE
 - ④ 6" WHITE TURN LANE LINE (2' LINE, 6' SPACE)
 - ⑤ 12" SOLID YELLOW DIAGONAL LINES
 - ⑥ 24" SOLID WHITE STOP BAR
 - ⑦ LETTERS AND SYMBOLS
 - ⑧ 12" SOLID WHITE DIAGONAL LINES
 - ⑨ RAISED REFLECTIVE PAVEMENT MARKERS
- ◁ ONE-WAY CRYSTAL
 - ◄ ONE-WAY AMBER
 - ◆ TWO-WAY AMBER

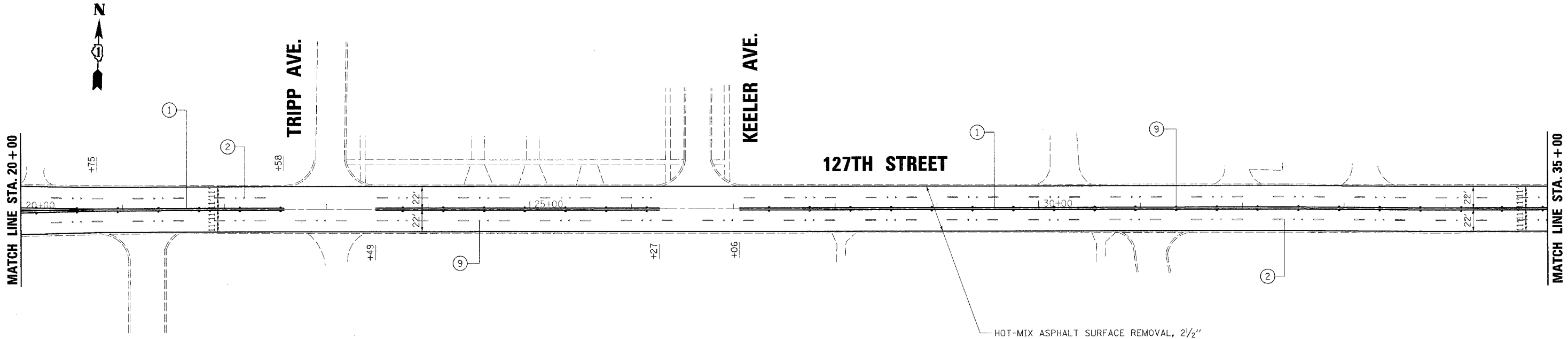
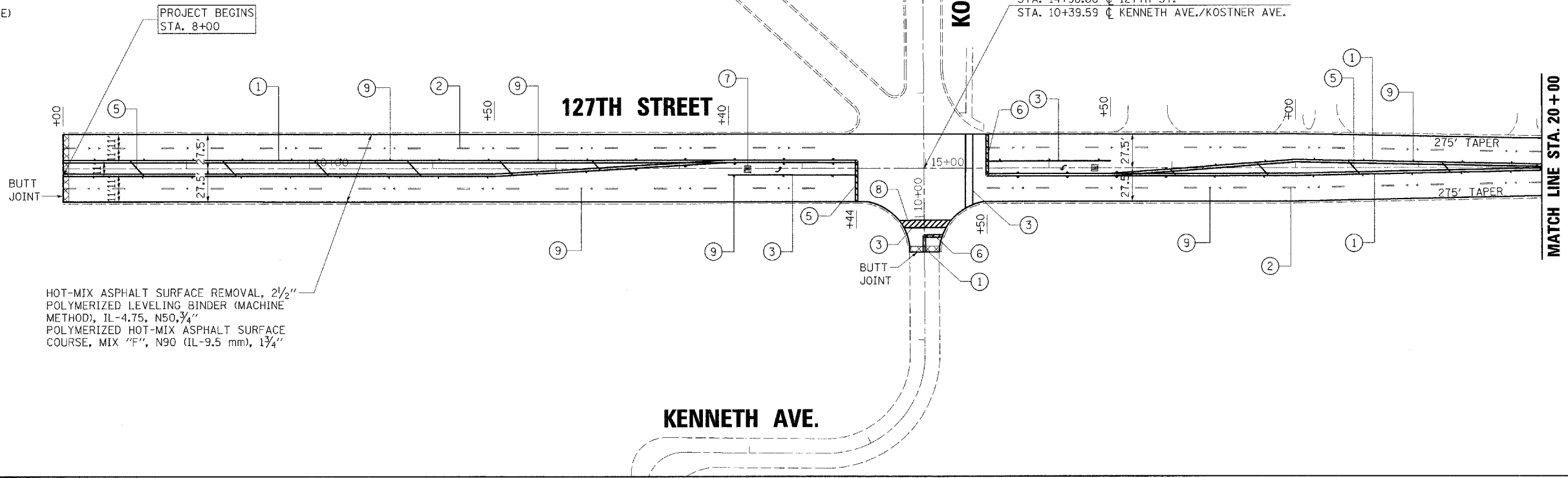

HOT-MIX ASPHALT SURFACE REMOVAL, 2 1/2"
 POLYMERIZED LEVELING BINDER (MACHINE METHOD), IL-4.75, N50, 3/4"
 POLYMERIZED HOT-MIX ASPHALT SURFACE COURSE, MIX "F", N90 (IL-9.5 mm), 1 1/4"

PLOT DATE = 4/18/2008
 FILE NAME = N:\11225505\11225505.dwg
 PLOT SCALE = 1"=50'
 PLOT NAME = 11225505.dwg
 MODEL =
 DEFLOT =



200 West Front Street
 Wheaton, IL 60187

DESIGNED - LCM	REVISED -
DRAWN - JMT	REVISED -
CHECKED - BLB	REVISED -
DATE - 3/28/08	REVISED -

**STATE OF ILLINOIS
 DEPARTMENT OF TRANSPORTATION**

**127th ST. (KOSTNER AVE. - CRAWFORD AVE.)
 EXISTING & PROPOSED ROADWAY PLAN**

SCALE: 1"=50' SHEET NO. 1 OF 2 SHEETS STA. 0+00 TO STA. 25+00

F.A.P. RTE.	SECTION	COUNTY	TOTAL SHEETS	SHEET NO.
344	3034 RS-4	COOK	21	6
CONTRACT NO. 60E30				

FED. ROAD DIST. NO. 1 [ILLINOIS] FED. AID PROJECT

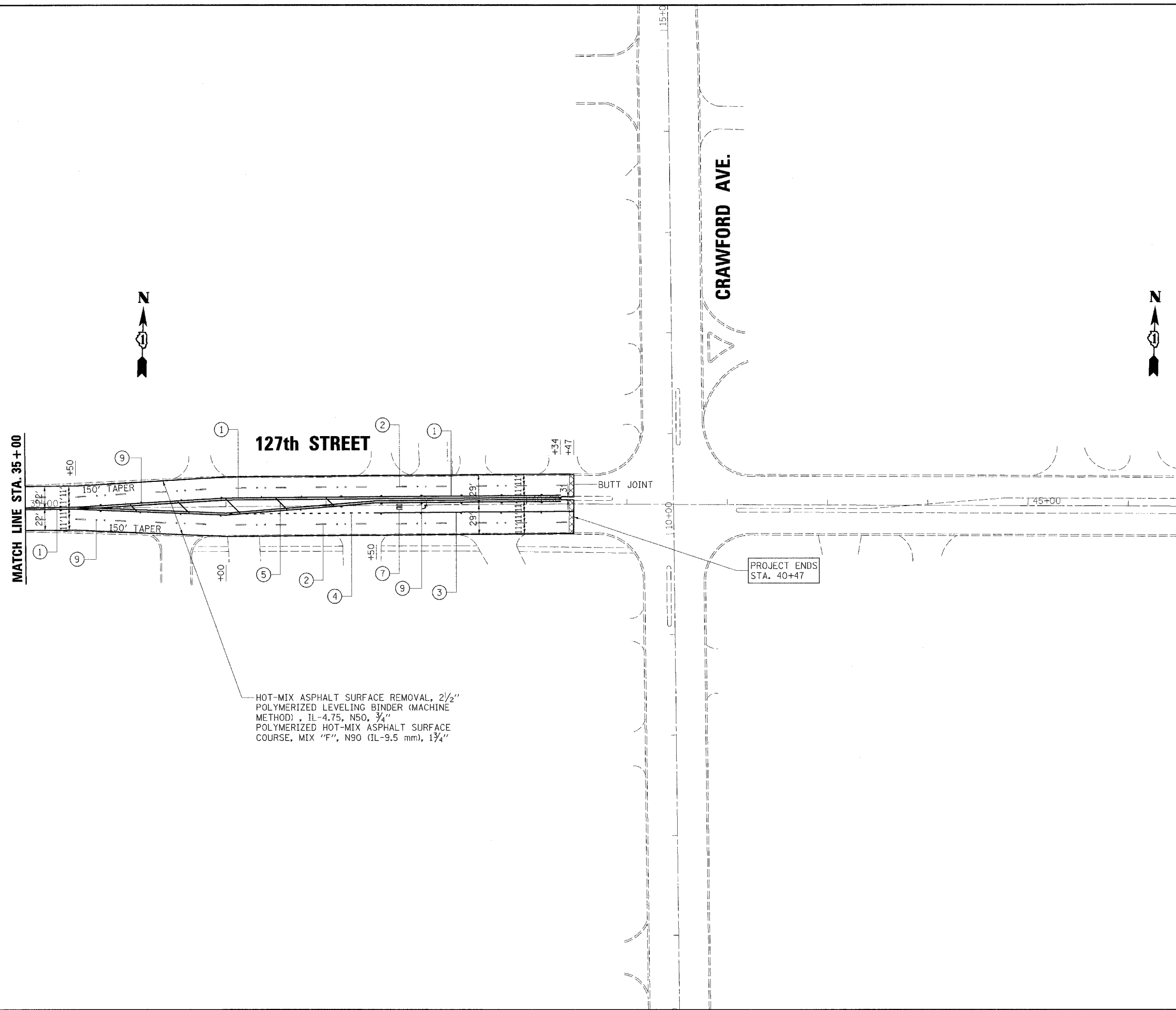

HOT-MIX ASPHALT SURFACE REMOVAL, 2 1/2" POLYMERIZED LEVELING BINDER (MACHINE METHOD), IL-4.75, N50, 3/4" POLYMERIZED HOT-MIX ASPHALT SURFACE COURSE, MIX "F", N90 (IL-9.5 mm), 1 3/4"

THERMOPLASTIC PAVEMENT MARKING LEGEND

- ① 4" DOUBLE SOLID YELLOW LINE (11" C-C)
 - ② 4" WHITE LANE LINE (10' LINE, 30' SPACE)
 - ③ 6" SOLID WHITE LINE
 - ④ 6" WHITE TURN LANE LINE (2' LINE, 6' SPACE)
 - ⑤ 12" SOLID YELLOW DIAGONAL LINES
 - ⑥ 24" SOLID WHITE STOP BAR
 - ⑦ LETTERS AND SYMBOLS
 - ⑧ 12" SOLID WHITE DIAGONAL LINES
 - ⑨ RAISED REFLECTIVE PAVEMENT MARKERS
- ◁ ONE-WAY CRYSTAL
 - ◄ ONE-WAY AMBER
 - ◆ TWO-WAY AMBER

4/10/2008
 R:\11225595\11225595.dgn
 jma
 Default



200 West Front Street
Wheaton, IL 60187

DESIGNED - LCM	REVISED -
DRAWN - JMT	REVISED -
CHECKED - BLB	REVISED -
DATE - 3/28/08	REVISED -

**STATE OF ILLINOIS
DEPARTMENT OF TRANSPORTATION**

**127th ST. (KOSTNER AVE. - CRAWFORD AVE.)
EXISTING & PROPOSED ROADWAY PLAN**

SCALE: 1"=50' SHEET NO. 2 OF 2 SHEETS STA. 25+00 TO STA. 37+00

F.A.P. RTE.	SECTION	COUNTY	TOTAL SHEETS	SHEET NO.
344	3034 RS-4	COOK	21	7
CONTRACT NO. 60E30				
<small>FED. ROAD DIST. NO. 1 ILLINOIS FED. AID PROJECT</small>				

RESURFACING - TRAFFIC SIGNAL SCHEDULE OF QUANTITIES

The "Pay Items" below are paid separately as per the attached "Specification" for MAGNETIC DETECTOR REMOVAL AND DETECTOR LOOP INSTALLATION.

NOTE:
THIS PLAN IS FOR THE PURPOSE OF REPLACING THE DETECTOR LOOPS ONLY. ALL OTHER INFORMATION SHOWN IS NOT RELATED AND WILL BE DISREGARDED.

Code No.	Pay Item	Unit	Quantity
85000200	MAINTENANCE OF EXISTING TRAFFIC SIGNAL INSTALLATION	EACH	
87301305	ELECTRIC CABLE IN CONDUIT, LEAD-IN, NO. 14 1 PAIR	FOOT	
88500100	INDUCTIVE LOOP DETECTOR	EACH	
88600100	DETECTOR LOOP, TYPE 1	FOOT	

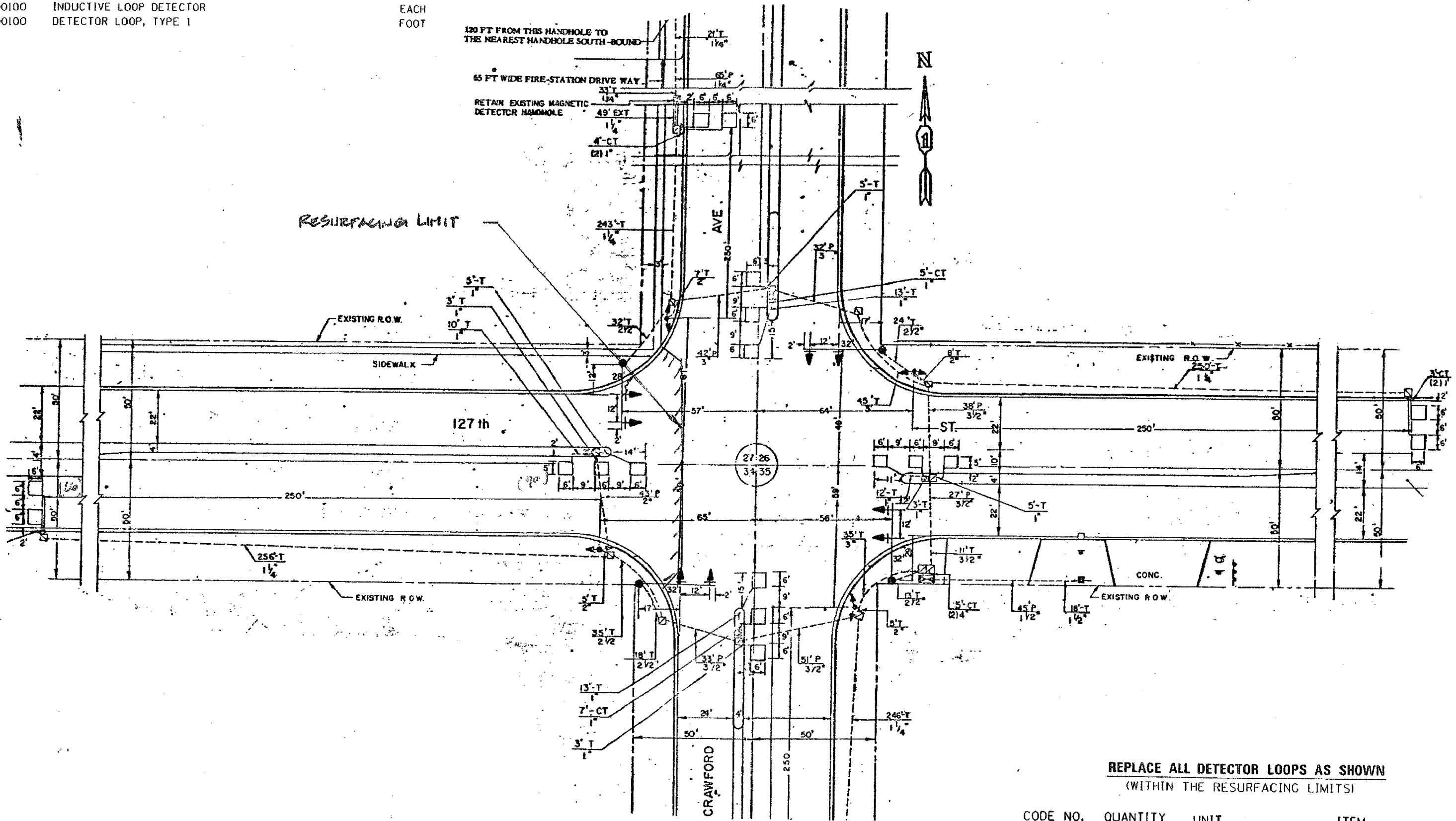

REPLACE ALL DETECTOR LOOPS AS SHOWN
(WITHIN THE RESURFACING LIMITS)

CODE NO.	QUANTITY	UNIT	ITEM
86600600	156	FOOT	DETECTOR LOOP REPLACEMENT

FILE NAME: \\projects\staff\ksh\070827\us12_20_45.dwg	USER NAME: kshthphxvqjbo	DESIGNED: -	REVISED: -	STATE OF ILLINOIS DEPARTMENT OF TRANSPORTATION	DETECTOR LOOP REPLACEMENT 127TH STREET @ CRAWFORD RD.	F.A.P. RATE: 344	SECTION: 3034 RS-4	COUNTY: COOK	TOTAL SHEETS: 21	SHEET NO.: 8
PLOT SCALE: 1/8" = 1'-0"	CHECKED: -	REVISED: -	REVISED: -			SCALE: SHEET NO. OF SHEETS STA. TO STA.	FED. ROAD DIST. NO. ILLINOIS FED. AID PROJECT			
PLOT DATE: 2/29/2008	DATE: -	REVISED: -	REVISED: -			CONTRACT NO. 60E30				
2/29/2008 1:37:00 PM User:kshthphxvqjbo										

RESURFACING - TRAFFIC SIGNAL SCHEDULE OF QUANTITIES

The "Pay Items" below are paid separately as per the attached "Specification" for MAGNETIC DETECTOR REMOVAL AND DETECTOR LOOP INSTALLATION.

Code No.	Pay Item	Unit	Quantity
85000200	MAINTENANCE OF EXISTING TRAFFIC SIGNAL INSTALLATION	EACH	
87301305	ELECTRIC CABLE IN CONDUIT, LEAD-IN, NO. 14 1 PAIR	FOOT	
88500100	INDUCTIVE LOOP DETECTOR	EACH	
88600100	DETECTOR LOOP, TYPE 1	FOOT	

NOTE:
THIS PLAN IS FOR THE PURPOSE OF REPLACING THE DETECTOR LOOPS ONLY. ALL OTHER INFORMATION SHOWN IS NOT RELATED AND WILL BE DISREGARDED.

TRAFFIC SIGNAL LEGEND

	PROPOSED	EXISTING
CONTROLLER	[Symbol]	[Symbol]
SERVICE INSTALLATION	[Symbol]	[Symbol]
SIGNAL HEAD OPTICALLY PROGRAMMED	[Symbol]	[Symbol]
SIGNAL HEAD	[Symbol]	[Symbol]
SIGNAL HEAD, PEDESTRIAN	[Symbol]	[Symbol]
SIGNAL POST	[Symbol]	[Symbol]
MAST ARM ASSEMBLY AND POLE, ALUMINUM	[Symbol]	[Symbol]
HANDHOLE	[Symbol]	[Symbol]
HEAVY DUTY HANDHOLE	[Symbol]	[Symbol]
DOUBLE HANDHOLE	[Symbol]	[Symbol]
C. S. CONDUIT IN TRENCH OR PUSHED	[Symbol]	[Symbol]
PEDESTRIAN PUSHBUTTON DETECTOR	[Symbol]	[Symbol]
SIGNAL FACE WITH BACKPLATE	[Symbol]	[Symbol]
COMMON TRENCH	[Symbol]	[Symbol]

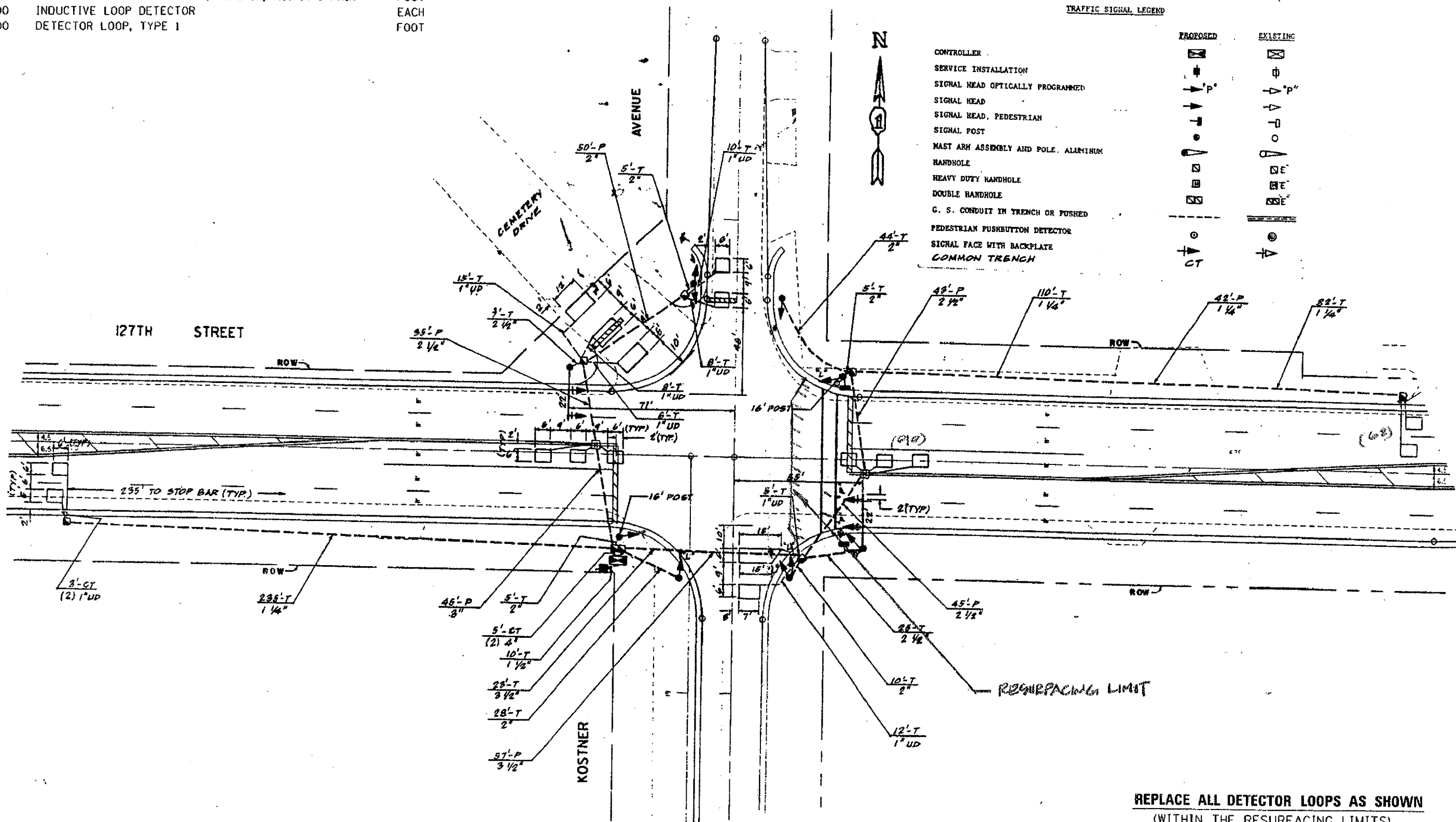

REPLACE ALL DETECTOR LOOPS AS SHOWN
(WITHIN THE RESURFACING LIMITS)

CODE NO.	QUANTITY	UNIT	ITEM
86600600	152	FOOT	DETECTOR LOOP REPLACEMENT

FILE NAME: c:\projects\traffic\1070027\us12.20.45.dwg	USER NAME: kenthphixgbc	DESIGNED: -	REVISED: -	STATE OF ILLINOIS DEPARTMENT OF TRANSPORTATION	DETECTOR LOOP REPLACEMENT 127TH STREET @ KOSTNER AVE.	F.A.P. RTE.:	SECTION:	COUNTY:	TOTAL SHEETS:	SHEET NO.:	
		DRAWN: -	REVISED: -			344	3034 RS-4	COOK	21	9	
		CHECKED: -	REVISED: -			SCALE:	SHEET NO. OF SHEETS	STA. TO STA.	CONTRACT NO. 60E30		
		DATE: 2/24/2008	REVISED: -						ILLINOIS FED. AID PROJECT		

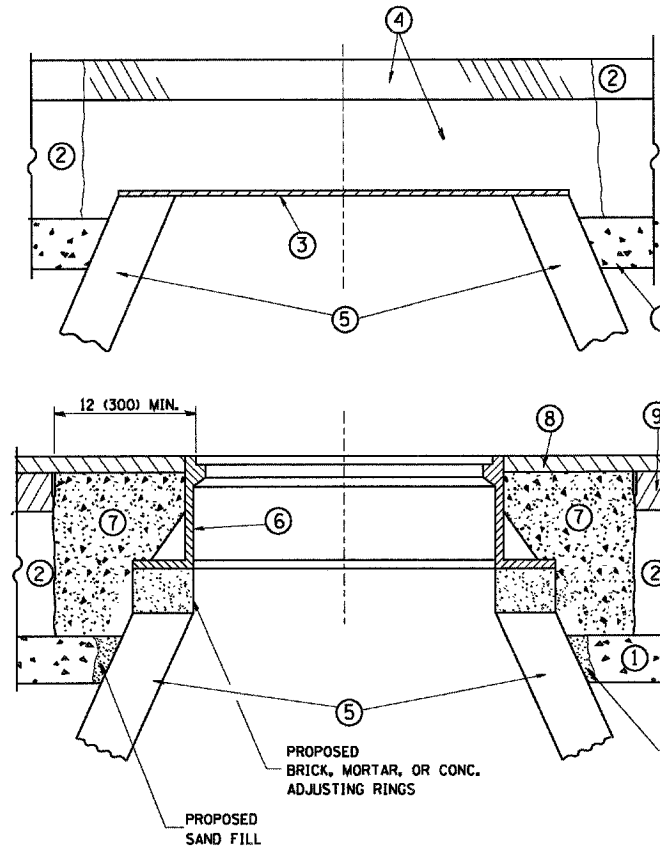

CONSTRUCTION PROCEDURES

STAGE 1 (BEFORE PAVEMENT MILLING)

- A) REMOVE A MINIMUM OF 12 (300) OF THE PAVEMENT FROM AROUND THE STRUCTURE.
- B) REMOVE THE EXISTING FRAME AND LID FROM THE STRUCTURE.
- C) COVER THE STRUCTURE OPENING WITH A 36 (900) DIAMETER METAL PLATE.
- D) BACKFILL WITH CRUSHED STONE AND A MINIMUM 1 1/2 (40) THICK HMA SURFACE MIX APPROVED BY THE ENGINEER.

STAGE 2 (AFTER PAVEMENT MILLING)

- A) REMOVE THE HMA SURFACE MIX AND CRUSHED STONE.
- B) INSTALL THE FRAME AND LID; ADJUST THE FRAME TO ITS FINAL SURFACE ELEVATION.
- C) THE SURROUNDING SPACE SHALL BE FILLED WITH CLASS SI CONCRETE, OR HMA SURFACE COURSE OR HMA BINDER COURSE TO THE ELEVATION OF THE SURFACE OF THE EXISTING BASE COURSE OR THE BINDER COURSE.

THE PROCEDURE EXPLAINED ABOVE SHALL CONFORM TO THE APPLICABLE PORTIONS OF SECTIONS 353, 406, 602, AND 603 OF THE STANDARD SPECIFICATIONS.

LEGEND

- ① SUB-BASE GRANULAR MATERIAL
- ② EXISTING PAVEMENT
- ③ 36 (900) DIAMETER METAL PLATE
- ④ PROPOSED CRUSHED STONE AND HMA SURFACE MIX
- ⑤ EXISTING STRUCTURE
- ⑥ FRAME AND LID (SEE NOTES)
- ⑦ CLASS SI CONCRETE, HMA SURFACE COURSE OR HMA BINDER COURSE
- ⑧ PROPOSED HMA SURFACE COURSE
- ⑨ PROPOSED HMA BINDER COURSE

LOCATION OF STRUCTURES:

THE CONTRACTOR WILL BE REQUIRED TO KEEP A RECORD OF THE LOCATIONS OF THE BURIED STRUCTURES ACCORDING TO THE STATION AND DISTANCE LEFT OR RIGHT OF THE CENTERLINE OF PAVEMENT. UPON COMPLETION OF THE WORK, THE CONTRACTOR WILL DELIVER THE RECORD TO THE ENGINEER.

BASIS OF PAYMENT: THIS WORK WILL BE PAID FOR AT THE CONTRACT UNIT PRICE PER EACH FOR "FRAMES AND LIDS TO BE ADJUSTED, SPECIAL"

NEW FRAMES AND LIDS, WHEN SPECIFIED, WILL BE PAID FOR SEPARATELY.

NOTES:

EXISTING BROKEN FRAMES AND LIDS SHALL BE REMOVED AND DISPOSED OF BY THE CONTRACTOR AND SHALL BE REPLACED AS DIRECTED BY THE ENGINEER. REPLACEMENT FRAMES AND LIDS WILL BE PAID FOR IN ACCORDANCE WITH ARTICLE 109.04 OF THE STANDARD SPECIFICATIONS UNLESS A SEPARATE PAY ITEM HAS BEEN PROVIDED.

IF THE EXISTING LIDS ARE OPEN, THE FRAME WILL BE ADJUSTED TO THE ELEVATION OF THE MILLED PAVEMENT SURFACE PRIOR TO THE MILLING OPERATION. THE FRAME WILL NOT BE REMOVED AND COVERED BY THE METAL PLATE.

CITY OF CHICAGO CASTINGS ARE THE PROPERTY OF THE CITY AND THE CONTRACTOR SHALL NOTIFY THE CITY FOR REMOVAL AND DISPOSITION OF THE CASTINGS.

THE METAL PLATE USED TO COVER THE STRUCTURE SHALL REMAIN THE PROPERTY OF THE CONTRACTOR.

WHEN STRUCTURES ARE TO BE ADJUSTED OR RECONSTRUCTED, THE LOWERING AND RAISING OF THE FRAMES AND LIDS WILL NOT BE PAID FOR SEPARATELY BUT WILL BE INCLUDED IN THE COST OF THE CORRESPONDING PAY ITEM.

DETAILS FOR FRAMES AND LIDS ADJUSTMENT WITH MILLING

ALL DIMENSIONS ARE IN INCHES (MILLIMETERS) UNLESS OTHERWISE SHOWN

4/18/2008
 FILE NAME = K:\11225865\31\shah\11225865_DETAL.DGN
 PLOT SCALE = 1/4"=1'-0"
 PLOT DATE = 1/4/2008
 USER = goglianob
 MODEL = 8028

FILE NAME =	USER NAME = goglianob	DESIGNED - R. SHAH	REVISED - R. SHAH 03-10-95
W:\stata\22x34\bd08.dgn		DRAWN -	REVISED - A. ABBAS 03-21-97
		CHECKED -	REVISED - R. WIEDEMAN 05-14-04
		DATE - 10-25-94	REVISED - R. BORO 01-01-07

**STATE OF ILLINOIS
 DEPARTMENT OF TRANSPORTATION**

DETAILS FOR FRAMES AND LIDS ADJUSTMENT WITH MILLING			
SCALE: NONE	SHEET NO. 1	OF 1 SHEETS	STA. TO STA.

F.A.P. RTE.	SECTION	COUNTY	TOTAL SHEETS	SHEET NO.
344	3034 RS-4	COOK	21	10
BD600-03 (BD-8)			CONTRACT NO. 60E30	
FED. ROAD DIST. NO. 1 ILLINOIS FED. AID PROJECT				

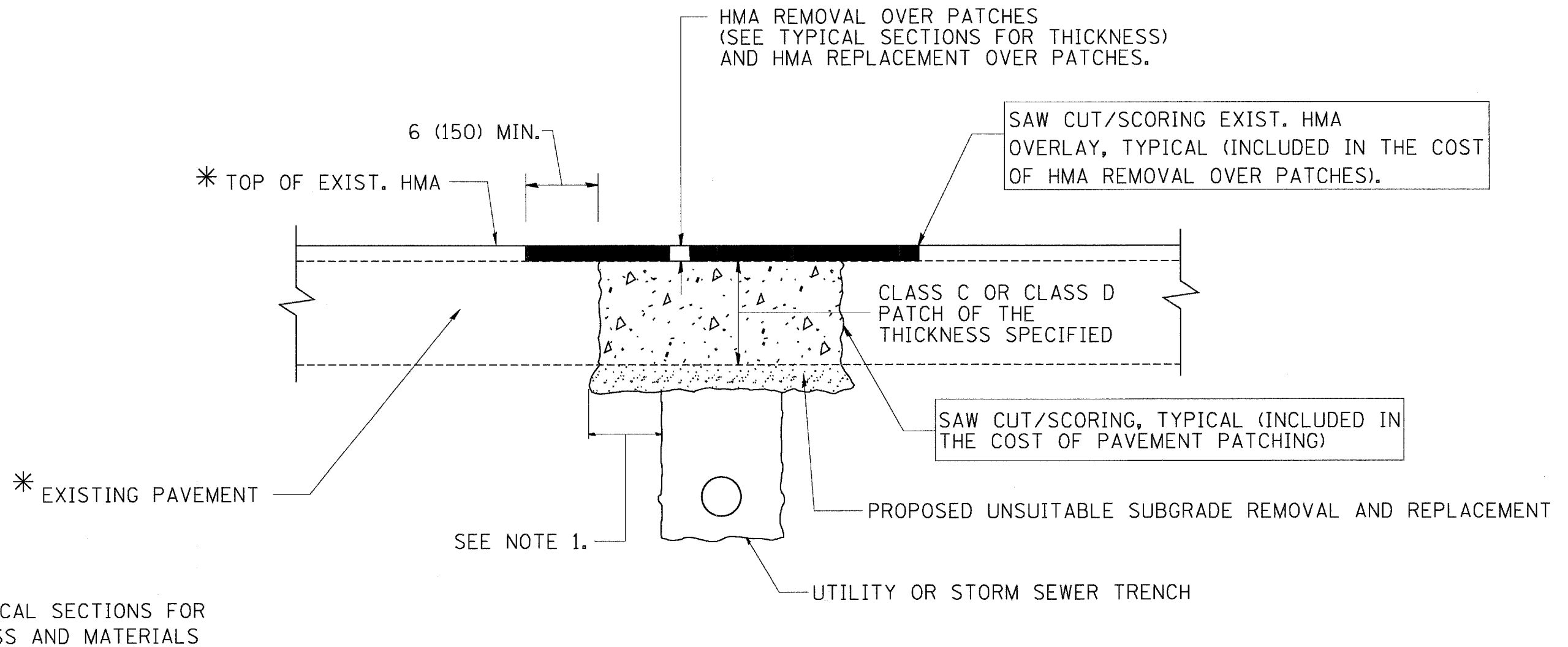

NOTES:

1. THE WIDTH OF THE FULL DEPTH PATCH OVER A TRENCH SHALL BE 12 (300) WIDER ON EACH SIDE OF THE TRENCH.
2. FOR METHOD OF MEASUREMENT AND BASIS OF PAYMENT, SEE RECURRING SPECIAL PROVISION "PATCHING WITH HOT-MIX ASPHALT OVERLAY REMOVAL".

SEQUENCE OF CONSTRUCTION

1. REMOVE THE EXISTING HMA MATERIAL OVER THE AREA TO BE PATCHED.
2. REMOVE AND REPLACE FULL DEPTH PATCHES
3. REPLACE HMA MATERIAL OVER THE AREA TO BE PATCHED.

ALL DIMENSIONS ARE IN INCHES (MILLIMETERS) UNLESS OTHERWISE SHOWN.

PLOT DATE = 4/18/2008
 FILE NAME = N:\1122525\1122525.dgn
 PLOT SCALE = 1/4" = 1'-0"
 USER NAME = jmartin
 MODEL = BD22

FILE NAME = W:\diststd\22x34\bd22.dgn	USER NAME = gaglanobt	DESIGNED - R. SHAH	REVISED - A. ABBAS 01-20-98
		DRAWN -	REVISED - A. ABBAS 04-27-98
PLOT SCALE = 50.000' / IN.	CHECKED -	REVISED - R. BORO 01-01-07	
PLOT DATE = 1/4/2008	DATE - 10-25-94	REVISED - R. BORO 09-04-07	

STATE OF ILLINOIS
DEPARTMENT OF TRANSPORTATION

PAVEMENT PATCHING FOR
HMA SURFACED PAVEMENT

SCALE: NONE SHEET NO. 1 OF 1 SHEETS STA. TO STA.

F.A.P. RTE.	SECTION	COUNTY	TOTAL SHEETS	SHEET NO.
344	3034 RS-4	COOK	21	11
BD400-04 (BD-22)			CONTRACT NO. 60E30	
FED. ROAD DIST. NO. 1 ILLINOIS FED. AID PROJECT				

VARIABLE - TO MEET EXISTING DIMENSIONS AND FIELD CONDITIONS (SEE NOTE ②)

PROP. CONC. CURB OR CURB AND GUTTER REPLACEMENT IN ACCORDANCE WITH STATE STANDARD 606001. (SEE NOTE ②)

SAW CUT FULL DEPTH - INCLUDED IN THE COST OF SIDEWALK, DRIVEWAY OR MEDIAN SURFACE REMOVAL PAY ITEM.

SEE STATE STANDARD 606001
EXISTING OR PROPOSED HMA SURFACE (IF APPLICABLE)

18" (450) MAX.

1/4" (5) **

EXISTING SIDEWALK, DRIVEWAY, MEDIAN SURFACE OR GROUND.

PROPOSED SIDEWALK, DRIVEWAY PAVEMENT, MEDIAN SURFACE OR SALT TOLERANT SOD AND TOP SOIL, 4" (100) SOD RESTORATION (SEE NOTE ①).

SUITABLE BACKFILL MATERIAL (INCLUDED IN THE COST OF CURB OR CURB AND GUTTER REMOVAL AND REPLACEMENT)

PROPOSED 3/4" (20) PREFORMED EXPANSION JOINT AT CONCRETE SIDEWALKS, DRIVEWAYS, AND MEDIANS. (INCLUDED IN THE COST OF CURB OR CURB AND GUTTER REMOVAL AND REPLACEMENT.)

3" (75) MIN.

UNSUITABLE SUB-BASE MATERIAL TO BE REMOVED, IF DIRECTED BY THE ENGINEER, SHALL BE REPLACED WITH EITHER SUB-BASE GRANULAR MATERIAL, TYPE B OR ADDITIONAL THICKNESS OF CONCRETE.

REMOVAL AND REPLACEMENT 4" (100) OR LESS IS INCLUDED IN THE COST OF CURB OR CURB AND GUTTER REMOVAL AND REPLACEMENT.

REMOVAL AND REPLACEMENT IN EXCESS OF 4" (100) WILL BE PAID FOR IN ACCORDANCE WITH ARTICLE 109.04 OF THE STANDARD SPECIFICATIONS.

PROPOSED #6 (20) EPOXY COATED TIE BARS 24" (600) LONG AT 24" (600) CENTERS WILL NOT BE PAID FOR SEPARATELY. DELETE EPOXY COATED TIE BARS IF EXISTING TIE BARS ARE USUABLE AS DETERMINED BY THE ENGINEER. (SEE NOTE ③).

BASIS OF PAYMENT:

THIS WORK WILL BE PAID FOR AT THE CONTRACT UNIT PRICE PER FOOT (METER) FOR "CURB REMOVAL AND REPLACEMENT" OR "COMBINATION CONCRETE CURB AND GUTTER REMOVAL AND REPLACEMENT".

* 3" (75) MINIMUM FROM TOP AND BOTTOM OF THE CONCRETE PAVEMENT OR BASE COURSE.

** IF THE FINAL SURFACE OF THE PAVEMENT IS CONCRETE, THE GUTTER IS TO BE FLUSH WITH THE PAVEMENT.

NOTE: ① SIDEWALK, DRIVEWAY PAVEMENT OR MEDIAN SURFACE SHALL BE SIMILAR TO THE MATERIAL BEING REMOVED AND WILL BE PAID FOR SEPARATELY.

SALT TOLERANT SOD AND TOP SOIL, 4" (100) RESTORATION WILL NOT BE PAID FOR SEPARATELY, BUT SHALL BE INCLUDED IN THE COST OF CURB OR CURB AND GUTTER REMOVAL AND REPLACEMENT.

② CURB OR CURB AND GUTTER REPLACEMENT SHALL MATCH THE SHAPE OF THE EXISTING CURB OR CURB AND GUTTER UNLESS OTHERWISE SPECIFIED.

③ FOR CURB OR CURB AND GUTTER REMOVAL AND REPLACEMENT ADJACENT TO FLEXIBLE PAVEMENT DELETE EPOXY COATED TIE BARS.

④ LONGITUDINAL BARS, IF ENCOUNTERED IN THE EXISTING CURB OR CURB AND GUTTER, ARE NOT TO BE REPLACED. CUTTING AND REMOVING LONGITUDINAL BARS SHALL BE INCLUDED IN THE COST OF CURB OR CURB AND GUTTER REMOVAL AND REPLACEMENT.

⑤ THE COST OF HMA SURFACE REMOVAL IN THE EXISTING GUTTER FLAG SHALL BE INCLUDED IN THE COST OF THE CURB AND GUTTER REMOVAL AND REPLACEMENT.

⑥ THE REMOVAL AND REPLACEMENT OF THE EXISTING CURB OR CURB AND GUTTER SHALL BE DONE IN ACCORDANCE WITH THE APPLICABLE PORTIONS OF SECTION 440 AND 606 OF THE STANDARD SPECIFICATIONS.

⑦ THE LOCATIONS OF REMOVAL AND REPLACEMENT OF EXISTING CURB OR CURB AND GUTTER SHALL BE DETERMINED BY THE RESIDENT ENGINEER AT THE TIME OF CONSTRUCTION.

CURB OR CURB AND GUTTER REMOVAL AND REPLACEMENT

ALL DIMENSIONS ARE IN INCHES (MILLIMETERS) UNLESS OTHERWISE SHOWN.

PLOT DATE = 4/18/2008
FILE NAME = N:\11225895\11225895.dgn
PLOT SCALE = 1/4" = 1'-0"
USER NAME = R024

FILE NAME = N:\11225895\11225895.dgn	USER NAME = geglianobt	DESIGNED - A. HOUSEH	REVISED - R. SHAH 10-03-96	STATE OF ILLINOIS DEPARTMENT OF TRANSPORTATION	CURB OR CURB AND GUTTER REMOVAL AND REPLACEMENT			F.A.P. RTE. = 344	SECTION = 3034 RS-4	COUNTY = COOK	TOTAL SHEETS = 21	SHEET NO. = 12
	PLOT SCALE = 58.000 "/ IN.	CHECKED -	REVISED - M. GOMEZ 01-22-01		SCALE: NONE	SHEET NO. 1 OF 1 SHEETS	STA. TO STA.	BD600-06 (BD-24) CONTRACT NO. 60E30				
	PLOT DATE = 1/4/2008	DATE = 03-11-94	REVISED - R. BORO 01-01-07		FED. ROAD DIST. NO. 1 (ILLINOIS) FED. AID PROJECT							

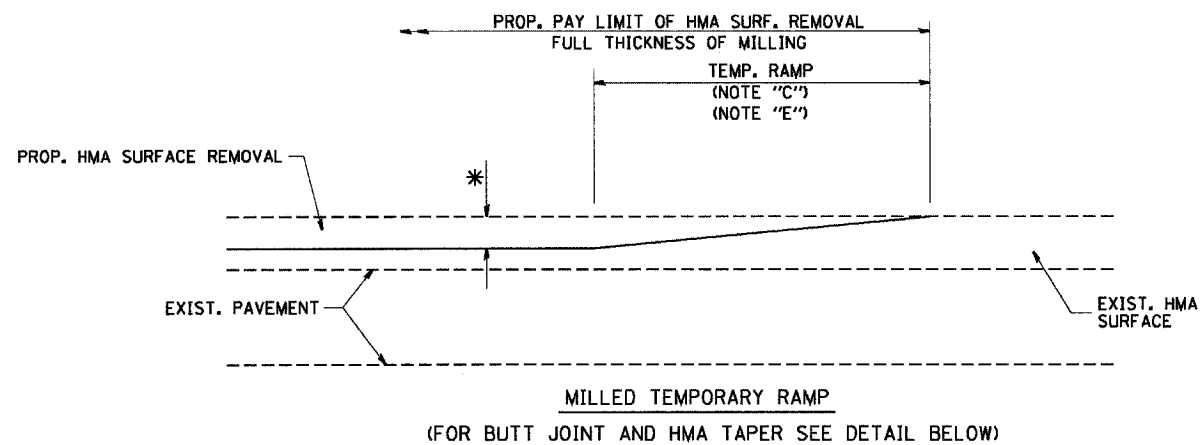

OPTION 1

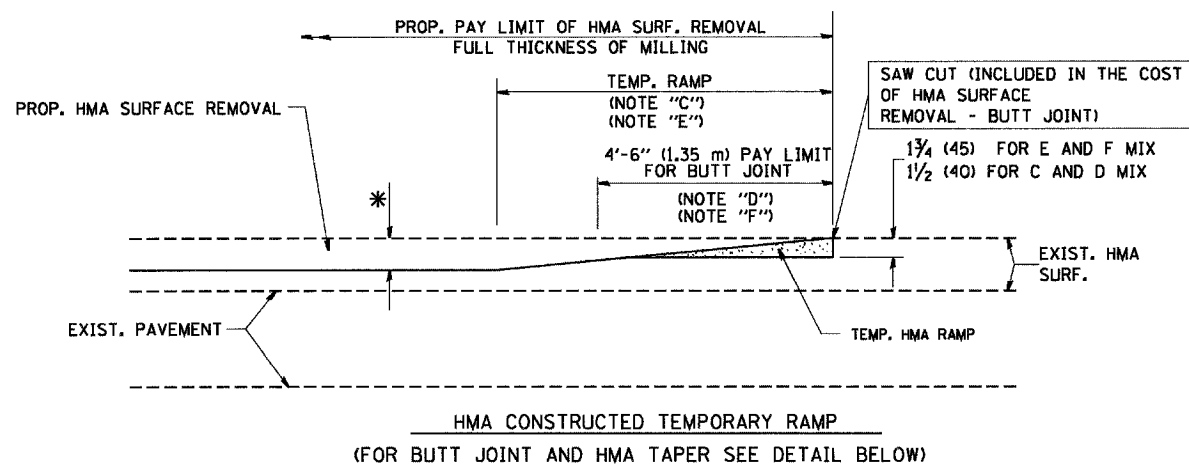

OPTION 2

TYPICAL TEMPORARY RAMP

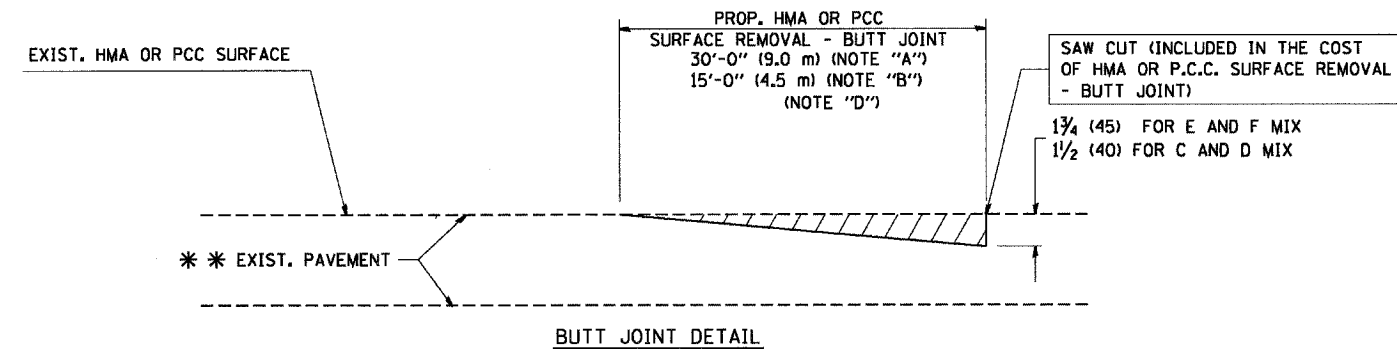

BUTT JOINT DETAIL

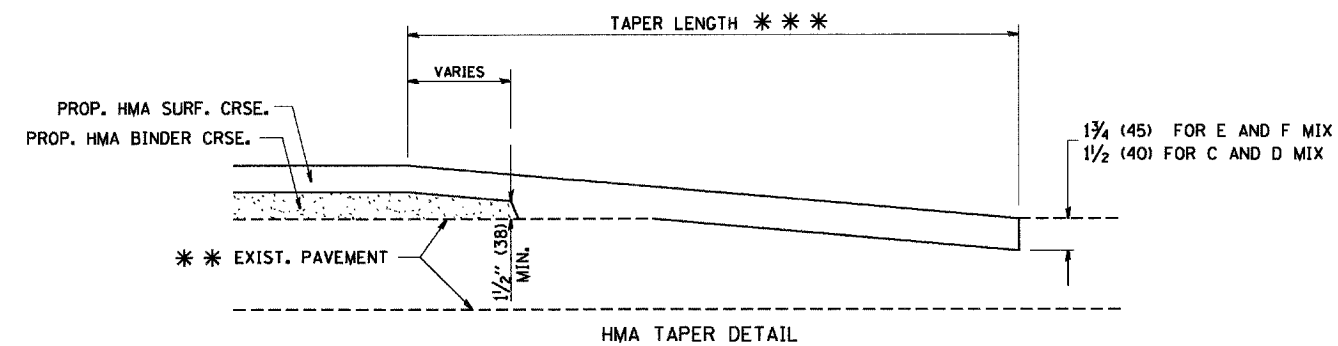

HMA TAPER DETAIL

TYPICAL BUTT JOINT AND HMA TAPER FOR RESURFACING ONLY

*** PC CONCRETE, HMA OR HMA RESURFACED PAVEMENT.

NOTES

- A: MAINLINE ROADWAYS AND MAJOR SIDE ROADS.
 - B: MINOR SIDE ROADS.
 - C: THE TEMP. RAMP SHALL BE CONSTRUCTED IMMEDIATELY UPON REMOVAL OF THE EXISTING HMA SURFACE.
 - D: THE BUTT JOINT SHALL BE CONSTRUCTED IMMEDIATELY PRIOR TO PLACING THE PROPOSED HMA COURSES.
 - E: TAPER THE TEMP. RAMP AT A RATE OF 3'-0" (900 mm) PER 1 INCH (25 mm) OF MILLING THICKNESS.
 - F: INSTALLATION AND REMOVAL OF THE 4'-6" (1.35 m) TEMP. RAMP IS INCLUDED IN COST OF HMA SURFACE REMOVAL - BUTT JOINT
 - G: SEE ARTICLE 406.08 AND 406.14 OF THE STANDARD SPECIFICATIONS FOR "HMA AND/OR PCC SURFACE REMOVAL, BUTT JOINT".
- * SEE TYPICAL SECTIONS FOR MILLING THICKNESS.
- *** 20'-0" (6.1 m) PER 1 (25) RESURFACING (NOTE "A")
 10'-0" (3.0 m) PER 1 (25) RESURFACING (NOTE "B")

BASIS OF PAYMENT:

THE BUTT JOINT WILL BE PAID FOR AT THE CONTRACT UNIT PRICE PER SQUARE YARD (SQUARE METER) FOR "HOT-MIX ASPHALT SURFACE REMOVAL - BUTT JOINT" OR FOR "PORTLAND CEMENT CONCRETE SURFACE REMOVAL - BUTT JOINT".

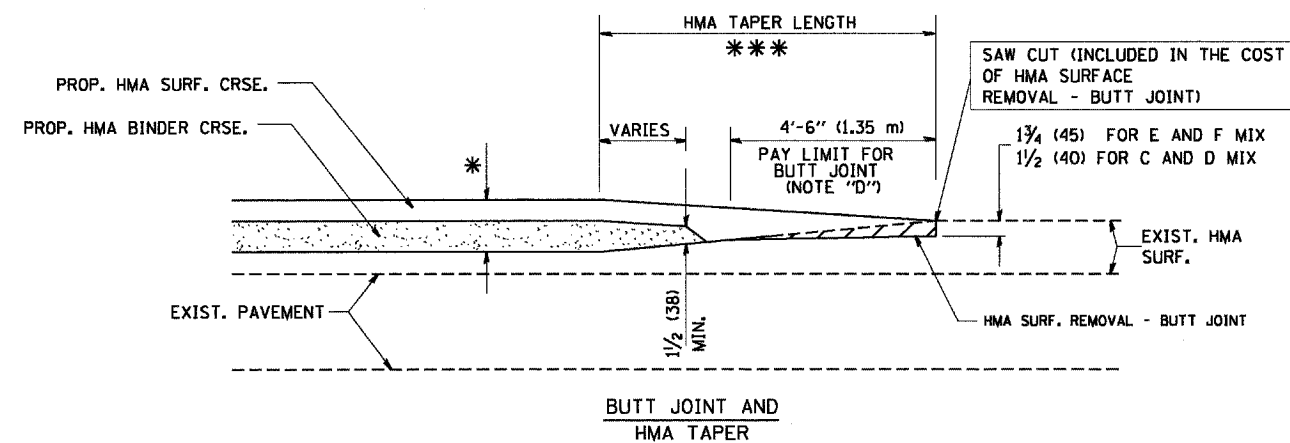

BUTT JOINT AND HMA TAPER

TYPICAL BUTT JOINT AND HMA TAPER FOR MILLING AND RESURFACING

ALL DIMENSIONS ARE IN INCHES (MILLIMETERS) UNLESS OTHERWISE SHOWN.

4/16/2008
 FILE NAME = K:\11225006\env\11225006\DETAIL.dgn
 PLOT SCALE = 58.0000 / IN.
 PLOT DATE = 1/4/2008
 USER = geglentobt
 MODEL = B032

FILE NAME = K:\11225006\env\11225006\DETAIL.dgn	USER NAME = geglentobt	DESIGNED - M. DE YONG	REVISED - R. SHAH 10-25-94
		DRAWN -	REVISED - A. ABBAS 03-21-97
	PLOT SCALE = 58.0000 / IN.	CHECKED -	REVISED - M. GOMEZ 04-06-01
	PLOT DATE = 1/4/2008	DATE - 06-13-90	REVISED - R. BORO 01-01-07

**STATE OF ILLINOIS
DEPARTMENT OF TRANSPORTATION**

BUTT JOINT AND HMA TAPER DETAILS

SCALE: NONE SHEET NO. 1 OF 1 SHEETS STA. TO STA.

F.A.P. RTE.	SECTION	COUNTY	TOTAL SHEETS	SHEET NO.
344	3034 RS-4	COOK	21	13
BD400-05 BD32			CONTRACT NO. 60E30	
FED. ROAD DIST. NO. 1 ILLINOIS FED. AID PROJECT				

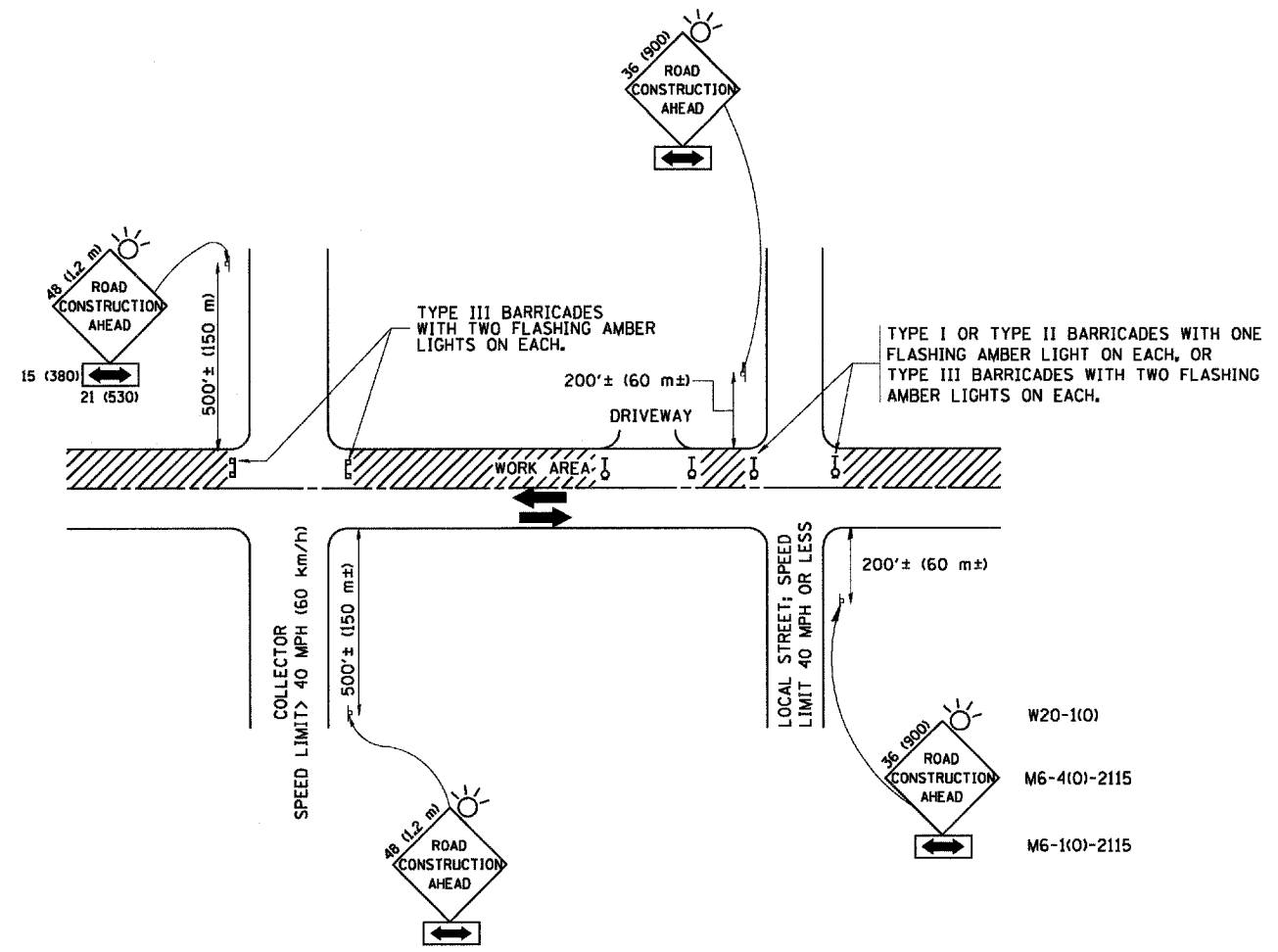

TRAFFIC CONTROL AND PROTECTION FOR SIDE ROADS, INTERSECTIONS, AND DRIVEWAYS

NOTES:

A. FOR NO LANE RESTRICTION ON THE SIDE ROAD OR DRIVEWAYS

1. SIDE ROAD WITH A SPEED LIMIT OF 40 MPH (60 km/h) OR LESS AS SHOWN ON THE DRAWING AND AS DIRECTED BY THE ENGINEER:
 - a) ONE ROAD CONSTRUCTION AHEAD SIGN 36 x 36 (900x900) WITH A FLASHER AND FLAG MOUNTED ON IT APPROXIMATELY 200' (60 m) IN ADVANCE OF THE MAIN ROUTE.
 - b) THE CLOSED PORTION OF THE MAIN ROUTE SHALL BE PROTECTED BY BLOCKING WITH TYPE I, TYPE II OR TYPE III BARRICADES, 1/3 OF THE CROSS SECTION OF THE CLOSED PORTION.
2. SIDE ROAD WITH A SPEED LIMIT GREATER THAN 40 MPH (60 km/h) AS SHOWN ON THE DRAWING AND AS DIRECTED BY THE ENGINEER:
 - a) ONE ROAD CONSTRUCTION AHEAD SIGN 48 x 48 (1.2 m x 1.2 m) WITH A FLASHER MOUNTED ON IT APPROXIMATELY 500' (150 m) IN ADVANCE OF THE MAIN ROUTE.
 - b) THE CLOSED PORTION OF THE MAIN ROUTE SHALL BE PROTECTED BY BLOCKING WITH TYPE III BARRICADES, 1/2 OF THE CROSS SECTION OF THE CLOSED PORTION.
3. WHEN THE SIDE ROAD LIES BETWEEN THE BEGINNING OF THE MAINLINE SIGNING AND THE WORK ZONE, A SINGLE HEADED ARROW (M6-1) SHALL BE USED IN LIEU OF THE DOUBLE HEADED ARROW (M6-4).

B. FOR A LANE CLOSURE ON A SIDE ROAD OR DRIVEWAY:

USE APPLICABLE PORTIONS OF THE TYPICAL APPLICATION OF TRAFFIC CONTROL DEVICES (STD. 701501, STD. 701606 OR THE APPROPRIATE STANDARD). THE SPACING OF SIGNS AND BARRICADES SHALL BE ADJUSTED FOR FIELD CONDITIONS AS DIRECTED BY THE ENGINEER. THE DIRECTIONAL ARROW SHALL BE COVERED OR REMOVED WHEN NO LONGER CONSISTENT WITH THE SIDE ROAD LANE CLOSURE.

C. ADVANCE WARNING SIGNS ARE TO BE OMITTED ON DRIVEWAY UNLESS OTHERWISE NOTED.

D. THE TRAFFIC CONTROL AND PROTECTION FOR SIDE ROADS, INTERSECTIONS, AND DRIVEWAYS SHALL BE INCIDENTAL TO THE COST OF SPECIFIED TRAFFIC CONTROL STANDARDS OR ITEMS.

All dimensions are in millimeters (inches) unless otherwise shown.

PLOT DATE = 4/18/2008
 FILE NAME = K:\11225085\ctwl\shesta\11225085_DET.TRIE.dgn
 PLOT SCALE = 50.000 X 1 IN.
 PLOT NAME = Interun
 MODEL = TC10

FILE NAME =	USER NAME = gaglianob	DESIGNED - LHA	REVISED - J. OBERLE 10-18-95
W:\diststd\22x34\ct10.dgn		DRAWN -	REVISED - A. HOUSEH 03-06-96
		CHECKED -	REVISED - A. HOUSEH 10-15-96
		DATE - 06-89	REVISED - T. RAMMACHER 01-06-00

STATE OF ILLINOIS
DEPARTMENT OF TRANSPORTATION

TRAFFIC CONTROL AND PROTECTION FOR SIDE ROADS, INTERSECTIONS, AND DRIVEWAYS			
SCALE: NONE	SHEET NO. 1 OF 1 SHEETS	STA.	TO STA.

F.A.P. RTE.	SECTION	COUNTY	TOTAL SHEETS	SHEET NO.
344	3034 RS-4	COOK	21	14
TC-10			CONTRACT NO. 60E30	
FED. ROAD DIST. NO. 1 ILLINOIS FED. AID PROJECT				

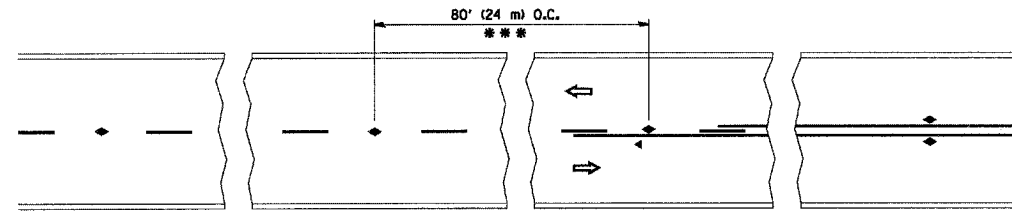

*** REDUCE TO 40' (12 m) O.C. ON CURVES WITH POSTED OR ADVISORY SPEED 45 M.P.H. (70 km/h) OR LESS.

TWO-LANE/TWO-WAY

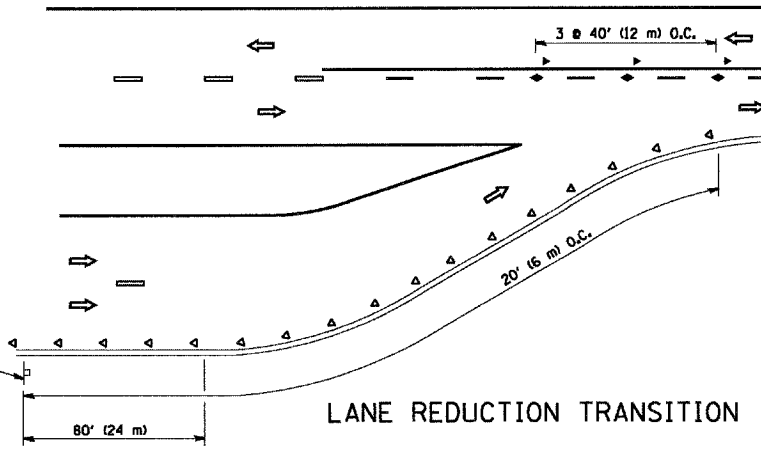

LANE REDUCTION TRANSITION

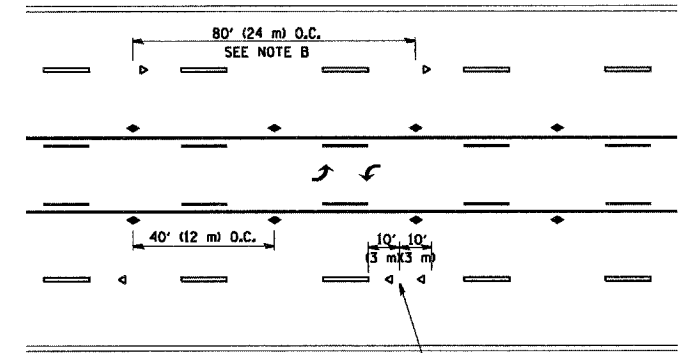

TWO-WAY LEFT TURN

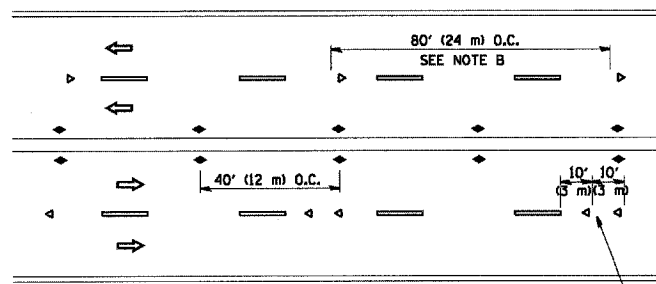

MULTI-LANE/UNDIVIDED

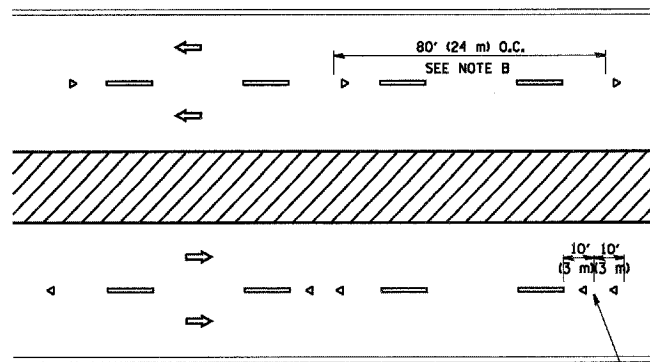

MULTI-LANE/DIVIDED

GENERAL NOTES

1. MARKERS USED WITH DASHED LINES SHALL BE CENTERED IN THE GAP BETWEEN SEGMENTS.
2. MARKERS USED ADJACENT TO SOLID LINES SHALL BE OFFSET 2 TO 3 (50 TO 75) TOWARD TRAFFIC AS SHOWN.
3. MARKERS THROUGH TANGENTS LESS THAN 500' (150 m) IN LENGTH BETWEEN CURVES SHALL BE INSTALLED AT THE LESSER OF THE TWO CURVE SPACINGS.

SYMBOLS

- YELLOW STRIPE
- WHITE STRIPE
- ◀ ONE-WAY AMBER MARKER
- ◀ ONE-WAY CRYSTAL MARKER (W/O)
- ◆ TWO-WAY AMBER MARKER

LANE MARKER NOTES

- B. REDUCE TO 40' (12 m) O.C. ON CURVES WHERE ADVISORY SPEEDS ARE 10 M.P.H. (20 km/h) LOWER THAN POSTED SPEEDS.
- A. USE DOUBLE LANE LINE MARKERS SPACED AS SHOWN.

DESIGN NOTES

1. DOUBLE LANE LINE MARKERS SHALL BE USED UNLESS SPECIFIED OTHERWISE.
2. EXCEPT AS SHOWN ON THE LANE REDUCTION TRANSITION AND FREEWAY EXIT RAMP DETAIL, MARKERS ARE NOT TO BE SPECIFIED ON RIGHT EDGE LINES.
3. THE EXACT MARKER LIMITS, SPACING, AND COLOR SHOULD BE INCLUDED IN THE PLANS.
4. MARKERS SHOULD NOT BE USED ALONGSIDE CURBS EXCEPT FOR EXTREMELY SHORT SECTIONS OF CURBS WHERE NOT MORE THAN TWO MARKERS WOULD BE INVOLVED.

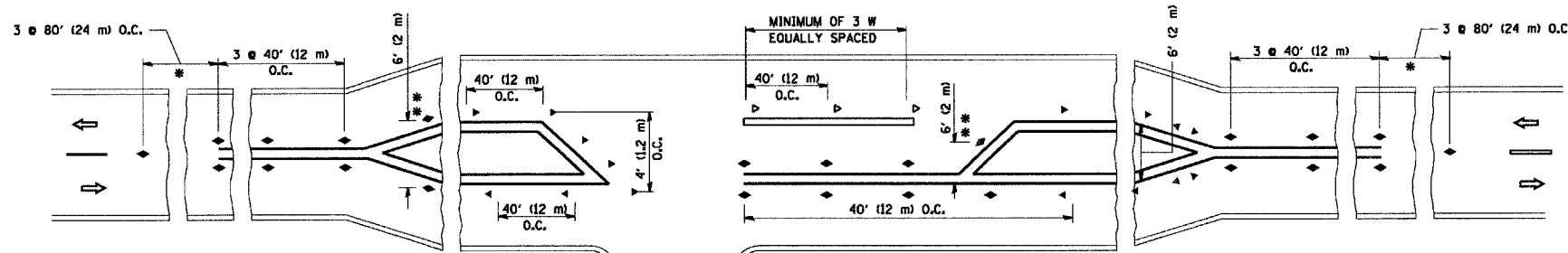

LEFT TURN

* SEE TWO-LANE/TWO-WAY WHERE MARKERS CONTINUE
 ** WHERE THE MEDIAN WIDTH IS 6' (2 m) OR LESS USE TWO-WAY MARKERS.

All dimensions are in inches (millimeters) unless otherwise shown.

PLOT DATE = 4/18/2008
 FILE NAME = K:\11225505\cavil\values\11225505_DE TRAIL.dgn
 PLOT SCALE = 1/8" = 1'-0"
 PLOT NAME = TCI
 MODEL =

FILE NAME =	USER NAME = gaglianob	DESIGNED -	REVISED - T. RAMMACHER 09-19-94
W:\dists\22x34\1\1.dgn		DRAWN -	REVISED - T. RAMMACHER 03-12-99
	PLOT SCALE = 50.000' / 1"	CHECKED -	REVISED - T. RAMMACHER 01-06-00
	PLOT DATE = 1/4/2008	DATE -	REVISED -

STATE OF ILLINOIS
 DEPARTMENT OF TRANSPORTATION

TYPICAL APPLICATIONS		F.A.P. RTE.	SECTION	COUNTY	TOTAL SHEETS	SHEET NO.
RAISED REFLECTIVE PAVEMENT MARKERS (SNOW-PLOW RESISTANT)		344	3034 RS-4	COOK	21	15
SCALE: NONE		SHEET NO. 1 OF 1 SHEETS		STA. TO STA.	CONTRACT NO. 60E30	
FED. ROAD DIST. NO. 1 ILLINOIS FED. AID PROJECT						

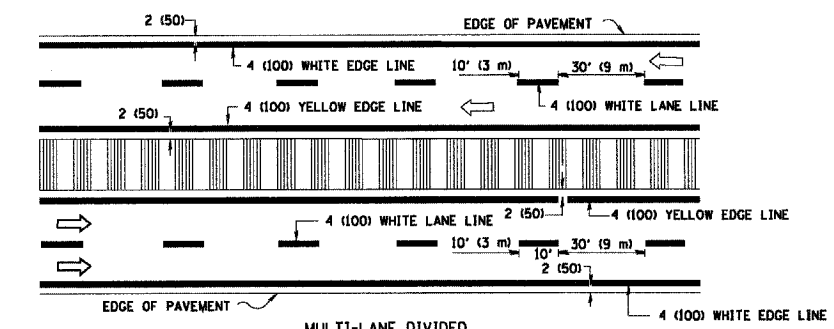
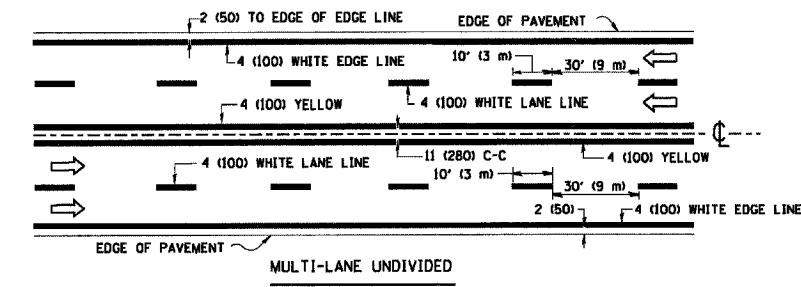
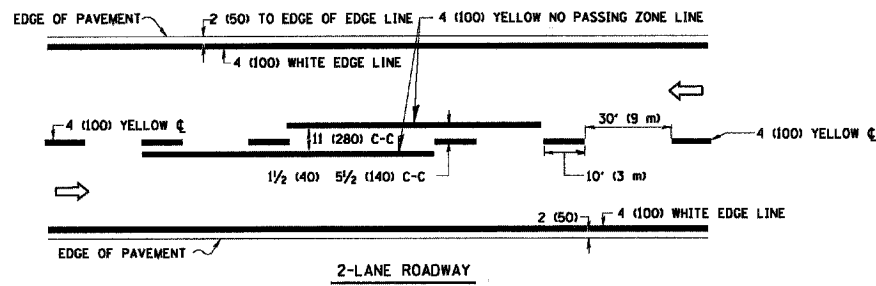

TYPICAL LANE AND EDGE LINE MARKING

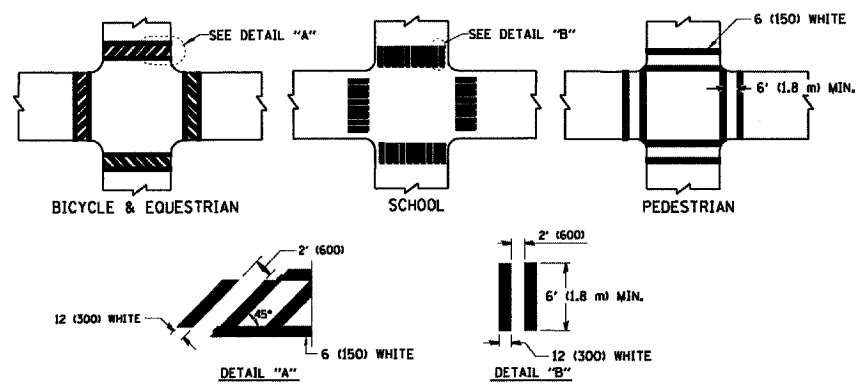

TYPICAL CROSSWALK MARKING

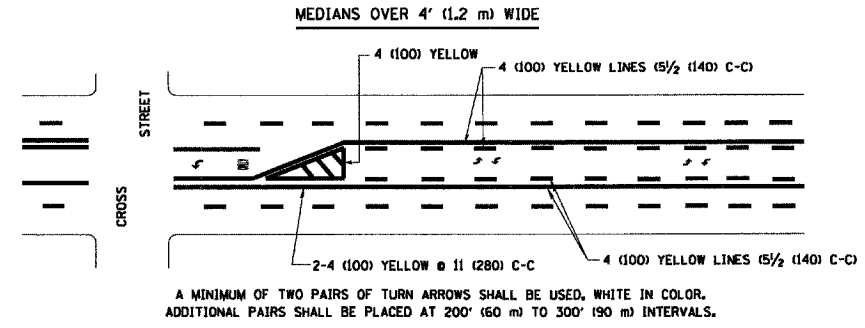
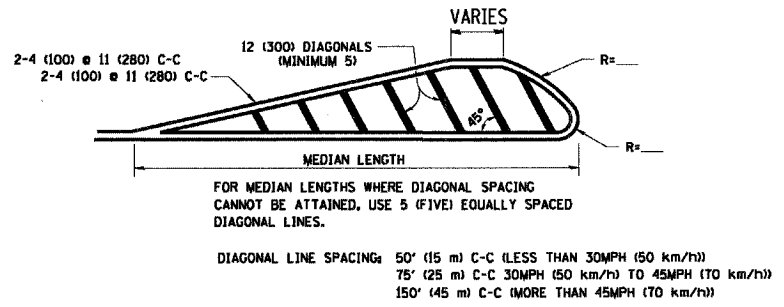
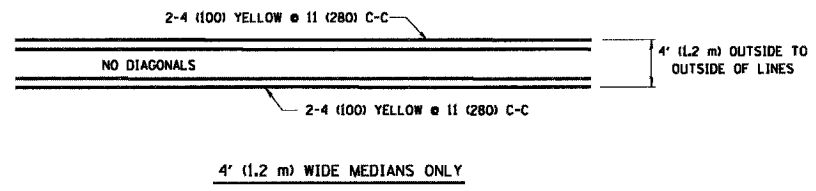

TYPICAL PAINTED MEDIAN MARKING

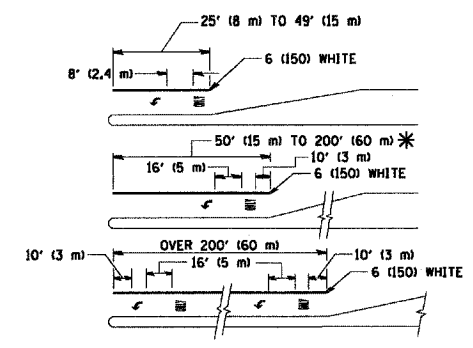

TYPICAL TURN LANE MARKING

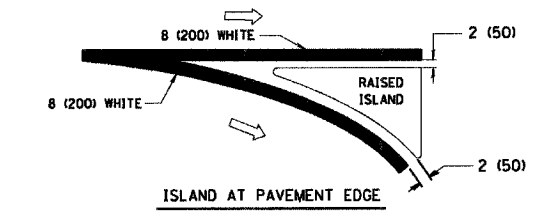
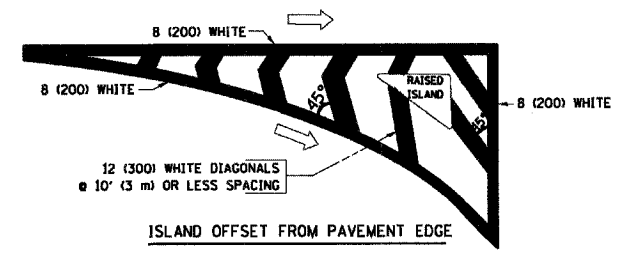

TYPICAL ISLAND MARKING

TYPE OF MARKING	WIDTH OF LINE	PATTERN	COLOR	SPACING / REMARKS
CENTERLINE ON 2 LANE PAVEMENT	4 (100)	SKIP-DASH	YELLOW	10' (3 m) LINE WITH 30' (9 m) SPACE
CENTERLINE ON MULTI-LANE UNDIVIDED PAVEMENT	2 @ 4 (100)	SOLID	YELLOW	11 (280) C-C
NO PASSING ZONE LINES FOR ONE DIRECTION FOR BOTH DIRECTIONS	4 (100) 2 @ 4 (100)	SOLID SOLID	YELLOW YELLOW	5 1/2 (140) C-C FROM SKIP-DASH CENTERLINE 11 (280) C-C OMIT SKIP-DASH CENTERLINE BETWEEN
LANE LINES	4 (100) 5 (125) ON FREEWAYS	SKIP-DASH SKIP-DASH	WHITE WHITE	10' (3 m) LINE WITH 30' (9 m) SPACE
DOTTED LINES (EXTENSIONS OF CENTER, LANE OR TURN LANE MARKINGS)	SAME AS LINE BEING EXTENDED	SKIP-DASH	SAME AS LINE BEING EXTENDED	2' (600) LINE WITH 6' (1.8 m) SPACE
EDGE LINES	4 (100)	SOLID	YELLOW-LEFT WHITE-RIGHT	OUTLINE MOUNTABLE MEDIANS IN YELLOW; EDGE LINES ARE NOT USED NEXT TO BARRIER CURB
TURN LANE MARKINGS	6 (150) LINE; FULL SIZE LETTERS & SYMBOLS (8' (2.4m))	SOLID	WHITE	SEE TYPICAL TURN LANE MARKING DETAIL
TWO WAY LEFT TURN MARKING	2 @ 4 (100) EACH DIRECTION 8' (2.4m) LEFT ARROW	SKIP-DASH AND SOLID IN PAIRS	YELLOW WHITE	10' (3 m) LINE WITH 30' (9 m) SPACE FOR SKIP-DASH; 5 1/2 (140) C-C BETWEEN SOLID LINE AND SKIP-DASH LINE SEE TYPICAL TWO-WAY LEFT TURN MARKING DETAIL
CROSSWALK LINES (PEDESTRIAN A. DIAGONALS (BIKE & EQUESTRIAN) B. LONGITUDINAL BARS (SCHOOL))	2 @ 6 (150) 12 (300) @ 45° 12 (300) @ 90°	SOLID SOLID SOLID	WHITE WHITE WHITE	NOT LESS THAN 6' (1.8 m) APART 2' (600) APART SEE TYPICAL CROSSWALK MARKING DETAILS.
STOP LINES	24 (600)	SOLID	WHITE	PLACE 4' (1.2 m) IN ADVANCE OF AND PARALLEL TO CROSSWALK, IF PRESENT. OTHERWISE, PLACE AT DESIRED STOPPING POINT, PARALLEL TO CROSSROAD CENTERLINE, WHERE POSSIBLE
PAINTED MEDIANS	2 @ 4 (100) WITH 12 (300) DIAGONALS @ 45° NO DIAGONALS USED FOR 4' (1.2 m) WIDE MEDIANS	SOLID	YELLOW; TWO WAY TRAFFIC WHITE; ONE WAY TRAFFIC	11 (280) C-C FOR THE DOUBLE LINE SEE TYPICAL PAINTED MEDIAN MARKING.
GORE MARKING AND CHANNELIZING LINES	8 (200) WITH 12 (300) DIAGONALS @ 45°	SOLID	WHITE	DIAGONALS: 15' (4.5 m) C-C (LESS THAN 30MPH (50 km/h)) 20' (6 m) C-C 30MPH (50 km/h) TO 45MPH (70 km/h) 30' (9 m) C-C (OVER 45MPH (70 km/h))
RAILROAD CROSSING	24 (600) TRANSVERSE LINES; "RR" 15 6' (1.8 m) LETTERS; 16 (400) LINE FOR "X"	SOLID	WHITE	SEE STATE STANDARD T80001 AREA OF: "R"=3.6 SQ. FT. (0.33 m²) EACH "X"=54.0 SQ. FT. (5.0 m²)
SHOULDER DIAGONALS	12 (300) @ 45°	SOLID	WHITE - RIGHT YELLOW - LEFT	50' (15 m) C-C (LESS THAN 30MPH (50 km/h)) 75' (25 m) C-C (30 MPH (50 km/h) TO 45MPH (70 km/h)) 150' (45 m) C-C (OVER 45MPH (70 km/h))

FOR FURTHER DETAILS ON PAVEMENT MARKING REFER TO STANDARD SPECIFICATIONS FOR ROAD AND BRIDGE CONSTRUCTION AND STATE STANDARD T80001.

All dimensions are in inches (millimeters) unless otherwise shown.

PLOT DATE = 4/18/2008
 FILE NAME = k:\11225695\cv\1\sheet\11225695_DET.TBL.dgn
 PLOT SCALE = 1/4" = 1'-0"
 PLOT NAME = 11225695_DET.TBL.dgn
 PLOT MODE = TC13

FILE NAME = k:\11225695\cv\1\sheet\11225695_DET.TBL.dgn	USER NAME = geglano	DESIGNED - EVERS	REVISED - T. RAMMACHER 10-27-94
		DRAWN -	REVISED - A. HOUSEH 10-09-96
		CHECKED -	REVISED - A. HOUSEH 10-17-96
		DATE - 03-19-90	REVISED - T. RAMMACHER 01-06-00

**STATE OF ILLINOIS
DEPARTMENT OF TRANSPORTATION**

**DISTRICT ONE
TYPICAL PAVEMENT MARKINGS**

SCALE: NONE SHEET NO. 1 OF 1 SHEETS STA. TO STA.

F.A.P. RTE.	SECTION	COUNTY	TOTAL SHEETS	SHEET NO.
344	3034 RS-4	COOK	21	16
TC-13		CONTRACT NO. 60E30		
FED. ROAD DIST. NO. 1 ILLINOIS FED. AID PROJECT				



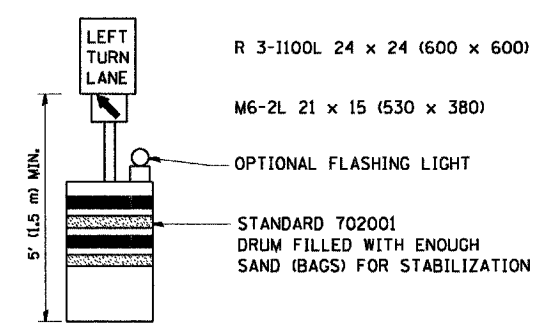
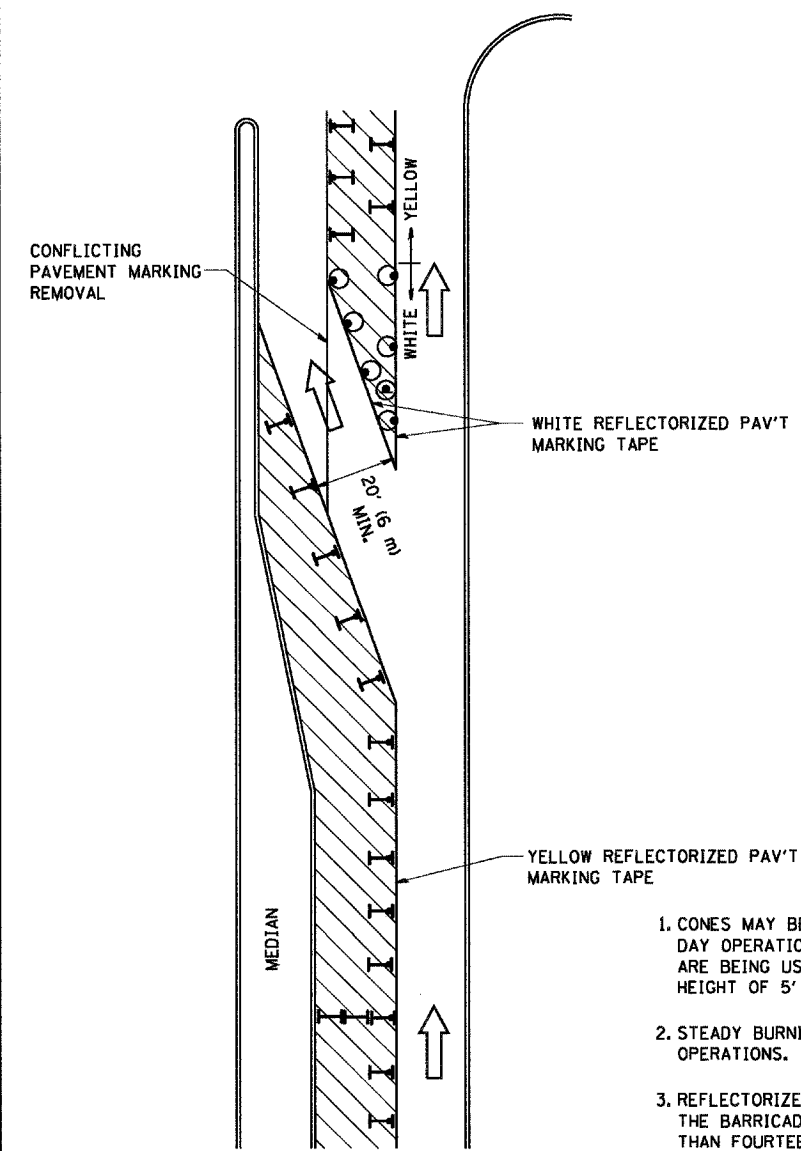

PLOT DATE = 4/19/2008
 FILE NAME = K:\11225506\11225506.DETAIL.S.dgn
 PLOT SCALE = 50.0000 / IN.
 USER NAME = gogianobt
 MODEL = TC14

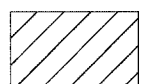
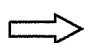

GENERAL NOTES

1. CONES MAY BE SUBSTITUTED FOR BARRICADES OR DRUMS AT HALF THE SPACING DURING DAY OPERATIONS. CONES SHALL BE A MINIMUM OF 28 (710) IN HEIGHT. WHEN CONES ARE BEING USED, THE "LEFT TURN LANE" SIGN MAY BE SKID MOUNTED AT A MINIMUM HEIGHT OF 5' (1.5 m).
2. STEADY BURNING LIGHTS WILL NOT BE REQUIRED ON BARRICADES OR DRUMS FOR DAY OPERATIONS. ALL LIGHTS SHALL BE MONODIRECTIONAL.
3. REFLECTORIZED TEMPORARY PAVEMENT MARKING TAPE SHALL BE PLACED THROUGHOUT THE BARRICADED AREA OF EACH TURN BAY WHERE THE CLOSURE TIME IS GREATER THAN FOURTEEN DAYS.
4. THIS APPLICATION ALSO APPLIES WHEN WORK IS BEING PERFORMED IN THE RIGHT LANE(S) AND THE RIGHT TURN BAY IS TO REMAIN OPEN. UNDER THIS CONDITION, "RIGHT TURN LANE" R3-100 24 x 24 (600 x 600) AND M6-2R 21 x 15 (530 x 380) SHALL BE USED.
5. THESE CONTROLS SHALL SUPPLEMENT MAINLINE TRAFFIC CONTROL FOR LANE CLOSURES.
6. LONGITUDINAL DIMENSIONS MAY BE ADJUSTED TO FIT FIELD CONDITIONS.
7. FORM BT 725 IS REQUIRED.
8. TRAFFIC CONTROL AND PROTECTION AT TURN BAYS (TO REMAIN OPEN TO TRAFFIC) SHALL BE INCLUDED IN THE COST SPECIFIED TRAFFIC CONTROL STANDARDS OR ITEMS.

LEGEND

-  WORK AREA
-  LANE OPEN TO TRAFFIC
-  TYPE I OR II BARRICADE WITH STEADY BURN LIGHT
-  DRUM WITH STEADY BURN LIGHT
-  DRUM WITH SIGN (WITH OPTIONAL FLASHING LIGHT) SEE DETAIL
-  TYPE I OR II CHECK BARRICADE WITH FLASHING LIGHT

All dimensions are in inches (millimeters) unless otherwise shown.

FILE NAME =	USER NAME = gogianobt	DESIGNED -	REVISED - T. RAMMACHER 09-08-94
W:\diststd\22x34\tcl14.dgn		DRAWN -	REVISED - A. HOUSEH 11-07-95
		CHECKED -	REVISED - A. HOUSEH 10-12-96
		DATE -	REVISED - T. RAMMACHER 01-06-00

**STATE OF ILLINOIS
 DEPARTMENT OF TRANSPORTATION**

TRAFFIC CONTROL AND PROTECTION AT TURN BAYS (TO REMAIN OPEN TO TRAFFIC)			
SCALE: NONE	SHEET NO. 1 OF 1 SHEETS	STA.	TO STA.

F.A.P. RTE.	SECTION	COUNTY	TOTAL SHEETS	SHEET NO.
344	3034 RS-4	COOK	21	17
TC-14		CONTRACT NO. 60E30		
FED. ROAD DIST. NO. 1 ILLINOIS FED. AID PROJECT				

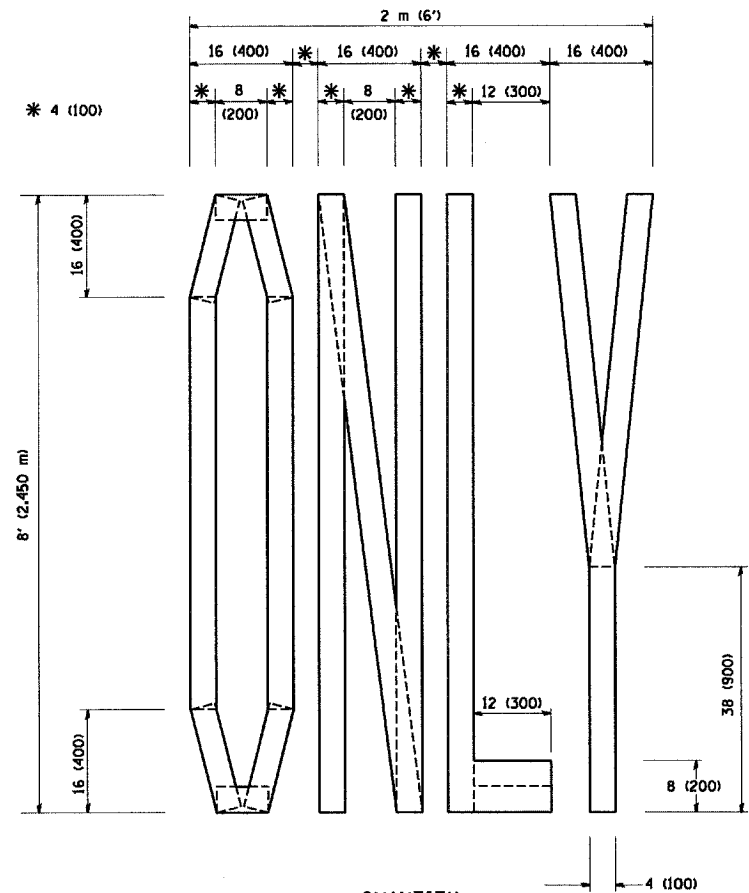

QUANTITY
 4 (100) LINE = 64.1 ft. (19.7 m)
 21.1 sq. ft. (1.97 sq. m)

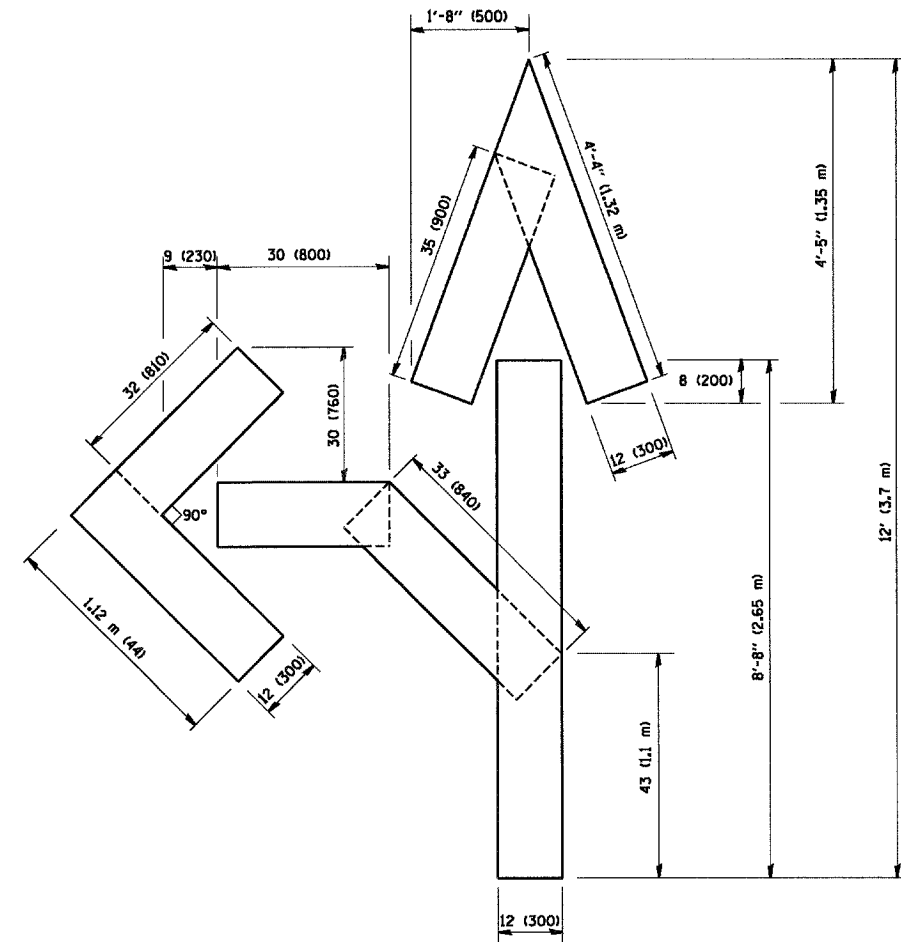

QUANTITY
 4 (100) LINE = 82.5 ft. (25.3 m)
 27.5 sq. ft. (2.53 sq. m)

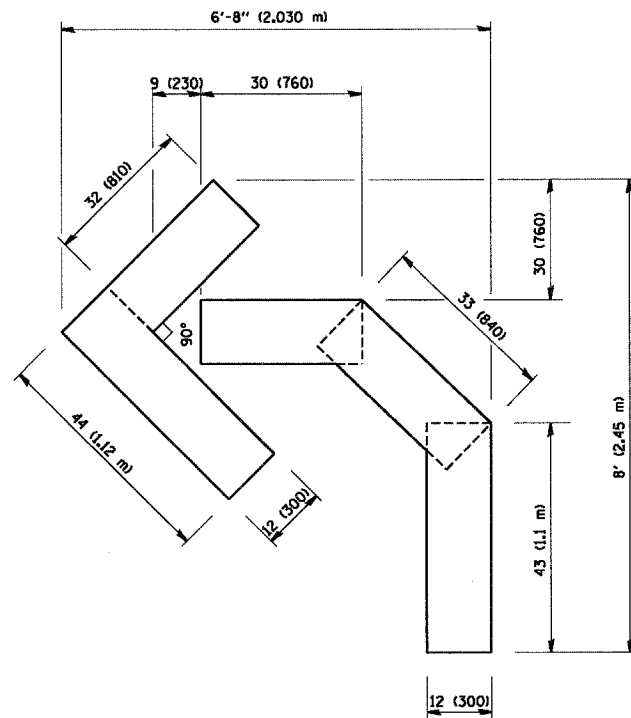

QUANTITY
 4 (100) LINE = 45.5 ft. (13.9 m)
 15.2 sq. ft. (1.39 sq. m)

All dimensions are in inches (millimeters) unless otherwise shown.

PLOT DATE = 4/10/2008
 FILE NAME = K:\11225905\001\shesha\11225905_DETAL16.dgn
 PLOT SCALE = 50.0000 / IN.
 PLOT NAME = Insetun
 MODEL = TC16

FILE NAME =	USER NAME = goglianpbt	DESIGNED -	REVISED - T. RAMMACHER 06-05-96
W:\sistatg\22x34\tc16.dgn		DRAWN -	REVISED - T. RAMMACHER 11-04-97
		CHECKED -	REVISED - T. RAMMACHER 03-02-98
		DATE - 09-18-94	REVISED - E. GOMEZ 08-28-00

STATE OF ILLINOIS
 DEPARTMENT OF TRANSPORTATION

PAVEMENT MARKING LETTERS AND SYMBOLS
 FOR TRAFFIC STAGING

SCALE: NONE SHEET NO. 1 OF 1 SHEETS STA. TO STA.

F.A.P. RTE.	SECTION	COUNTY	TOTAL SHEETS	SHEET NO.
344	3034 RS-4	COOK	21	18
TC-16		CONTRACT NO. 60E30		
FED. ROAD DIST. NO. 1 ILLINOIS FED. AID PROJECT				

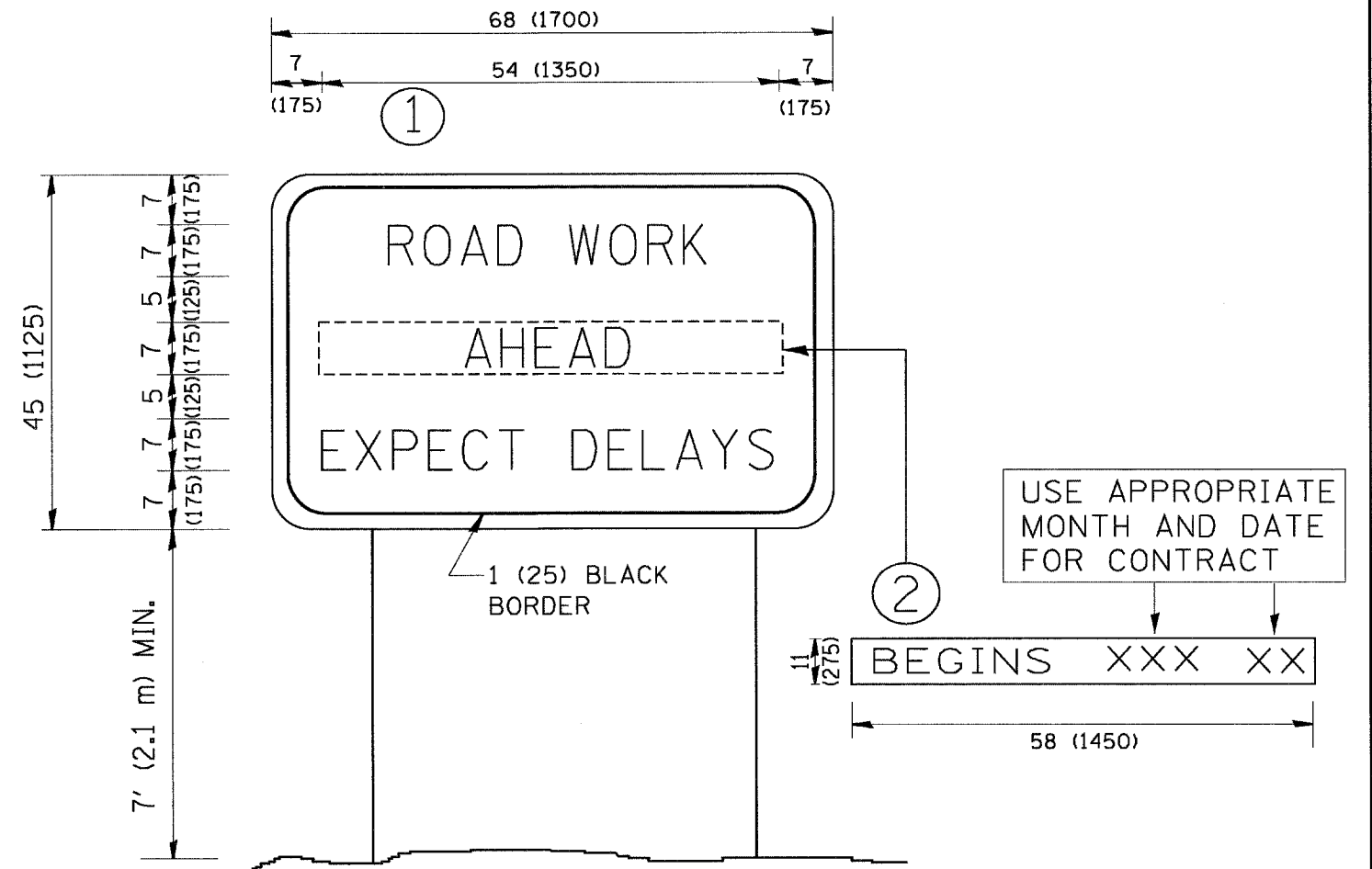

NOTES:

1. USE BLACK LETTERING ON ORANGE BACKGROUND.
2. ERECT SIGNS IN ADVANCE OF THE LOCATION FOR THE "ROAD CONSTRUCTION AHEAD" SIGN AT LOCATIONS AS DIRECTED BY THE ENGINEER.
3. ERECT SIGN ① WITH INSTALLED PANEL ② ONE WEEK PRIOR TO THE START OF CONSTRUCTION.
4. REMOVE PANEL ② SOON AFTER THE START OF CONSTRUCTION.
5. SEE SPECIAL PROVISION FOR "TEMPORARY INFORMATION SIGNING" FOR ADDITIONAL INFORMATION.
6. ONE SIGN ASSEMBLY EQUALS 25.70 SQ. FT. (2.3 SQ. M.)
7. SHALL BE PAID FOR AS TEMPORARY INFORMATION SIGNING.

ALL DIMENSIONS ARE IN INCHES (MILLIMETERS) UNLESS OTHERWISE SHOWN.

PLOT DATE = 4/18/2008
 FILE NAME = H:\11225606\11225606.DETAIL.DGN
 PLOT SCALE = 1/4" = 1'-0"
 PLOT NAME = TC22
 MODEL =

FILE NAME = W:\diststd\22x34\to22.dgn	USER NAME = gaglienobt	DESIGNED -	REVISED - R. MIRS 09-15-97
		DRAWN -	REVISED - R. MIRS 12-11-97
PLOT SCALE = 50.000 ' / IN.	CHECKED -	REVISED - T. RAMMACHER 02-02-99	
PLOT DATE = 1/4/2008	DATE -	REVISED - C. JUCIUS 01-31-07	

**STATE OF ILLINOIS
DEPARTMENT OF TRANSPORTATION**

**ARTERIAL ROAD
INFORMATION SIGN**

SCALE: NONE SHEET NO. 1 OF 1 SHEETS STA. TO STA.

F.A.P. RTE.	SECTION	COUNTY	TOTAL SHEETS	SHEET NO.
344	3034 RS-4	COOK	21	19
TC-22			CONTRACT NO. 60E30	
FED. ROAD DIST. NO. 1 ILLINOIS FED. AID PROJECT				

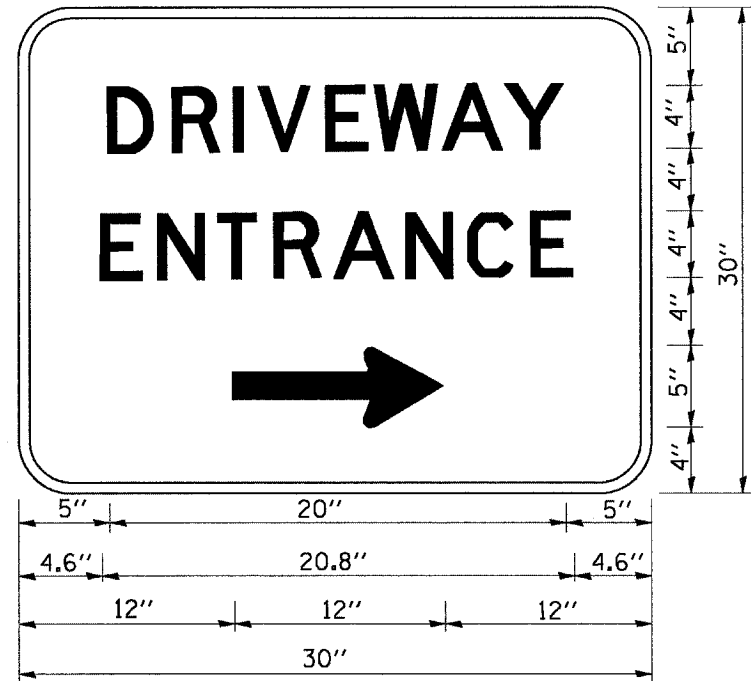

3.0" RADIUS, 0.5" BORDER, WHITE ON GREEN; REFLECTORIZED
 "DRIVEWAY" D; "ENTRANCE" D; STANDARD ARROW CUSTOM 12.0" x 5.0"

NOTES:

1. HALF OF THE SIGNS WILL REQUIRE A LEFT HAND FACING ARROW.
2. TWO SIGNS SHALL BE USED AT EACH COMMERCIAL ENTRANCE PLACED BACK-TO-BACK; ONE WITH A RIGHT HAND ARROW (SHOWN) SHALL BE PLACED ON THE NEAR RIGHT SIDE THE DRIVEWAY AND ONE WITH A LEFT HAND ARROW SHALL BE PLACED ON THE FAR LEFT SIDE OF THE DRIVEWAY.
3. SIGNS TO BE PAID FOR AS ITEM "TEMPORARY INFORMATION SIGNING".

PLOT DATE = 4/18/2008
 FILE NAME = K:\11225005\sheet\11225005.DWG
 PLOT SCALE = 1/4" = 1'-0"
 PLOT NAME = 11225005
 MODEL = TC26

FILE NAME = K:\11225005\sheet\11225005.DWG	USER NAME = gaglianobt	DESIGNED - DRAWN -	REVISED - REVISED -	C. JUCIUS 02-15-07	STATE OF ILLINOIS DEPARTMENT OF TRANSPORTATION	DRIVEWAY ENTRANCE SIGNING			F.A.P. RTE. 344	SECTION 3034 RS-4	COUNTY COOK	TOTAL SHEETS 21	SHEET NO. 20
PLOT SCALE = 50.000 ' / IN.	CHECKED -	REVISED -	REVISED -			SCALE: NONE SHEET NO. 1 OF 1 SHEETS STA. TO STA.			TC-26 CONTRACT NO. 60E30				
PLOT DATE = 1/4/2008	DATE -	REVISED -	REVISED -			FED. ROAD DIST. NO. 1 ILLINOIS FED. AID PROJECT							

LOOPS NEXT TO SHOULDERS

PROVIDE A PAVEMENT REPLACEMENT NOTE WHICH SHOULD EQUAL 3' (900 mm) X WIDTH OF PAVED SHOULDER.

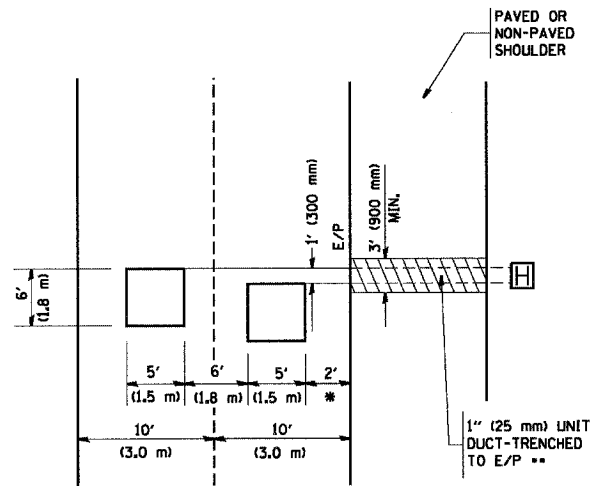

* = (600 mm)

** UNIT DUCT IS TO BE SHOWN ON PLAN SHEETS BUT SHALL NOT BE INCLUDED IN THE PAY ITEMS.

**LEFT TURN LANES WITH MEDIANS
VOLUME DENSITY ("FAR OUT" DETECTION)
ON SAME APPROACH
(PROTECTED / PERMITTED LEFT TURN PHASING)**

HANDHOLE LOCATION MAY VARY DEPENDING ON GEOMETRICS AND DESIGN OF TRAFFIC SIGNALS. HEAVY-DUTY HANDHOLES TO BE USED WHEN THE MEDIAN IS MOUNTABLE. REFER TO STANDARD 814001 TO ENSURE THAT HANDHOLE FITS IN MEDIAN.

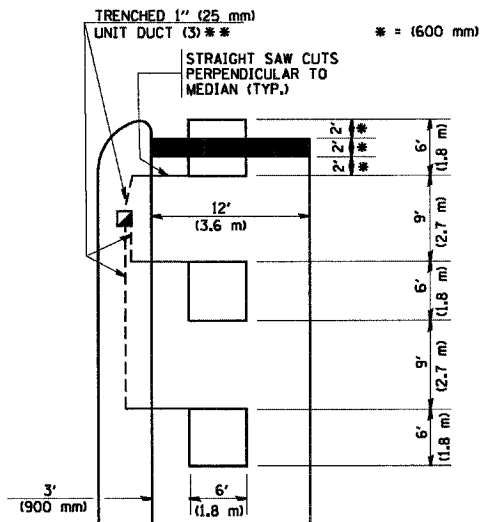

** UNIT DUCT IS TO BE SHOWN ON PLAN SHEETS BUT SHALL NOT BE INCLUDED IN THE PAY ITEMS.

NOTE: DUAL LEFT TURNS NOT SHOWN REFER TO PLAN SHEET FOR DETECTOR LOOP REPLACEMENT

**LEFT TURN LANES WITHOUT MEDIANS
VOLUME DENSITY ("FAR OUT" DETECTION)
ON SAME APPROACH
(PROTECTED / PERMITTED LEFT TURN PHASING)**

* = (600 mm)

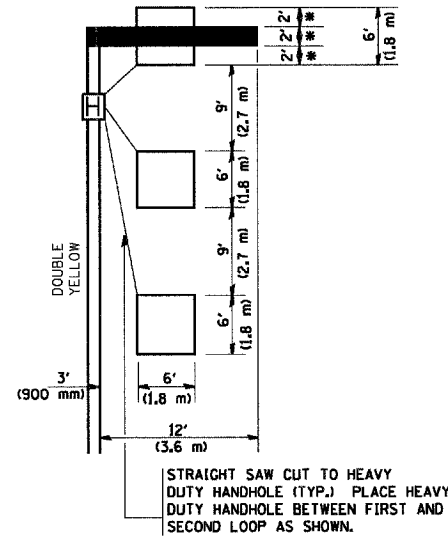

NOTE: DUAL LEFT TURNS NOT SHOWN REFER TO PLAN SHEET FOR DETECTOR LOOP REPLACEMENT

**ARTERIAL-VOLUME DENSITY ("FAR OUT" DETECTION)
CROSS STREET-VOLUME DENSITY ("FAR OUT" DETECTION)**

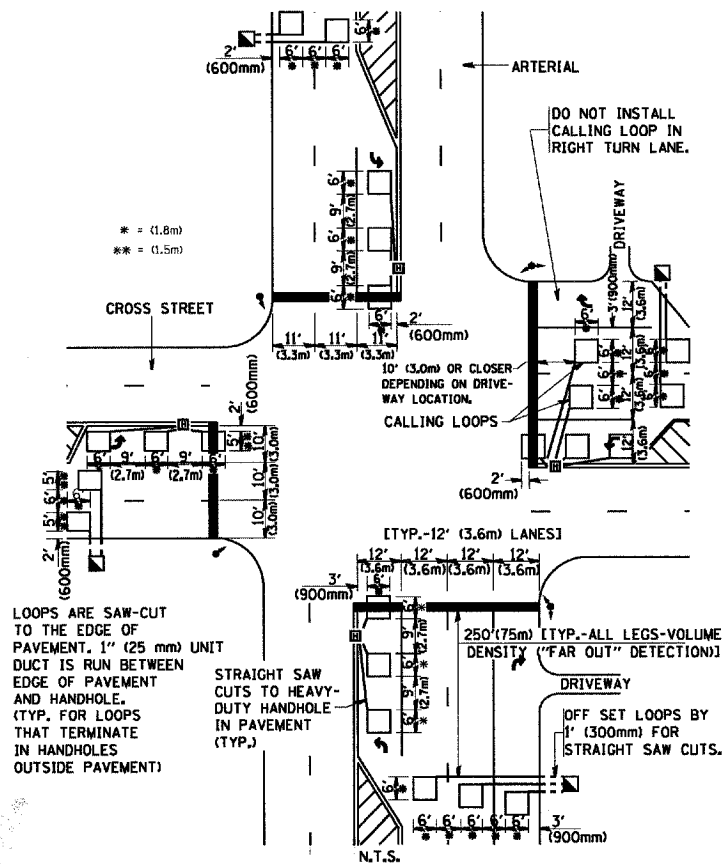

LOOPS ARE SAW-CUT TO THE EDGE OF PAVEMENT. 1" (25 mm) UNIT DUCT IS RUN BETWEEN EDGE OF PAVEMENT AND HANDHOLE. (TYP. FOR LOOPS THAT TERMINATE IN HANDHOLES OUTSIDE PAVEMENT)

DETAIL 1
N.T.S.

**ARTERIAL-VOLUME DENSITY ("FAR OUT" DETECTION)
CROSS STREET-NON VOLUME DENSITY ("UPTIGHT" PRESENCE DETECTION)**

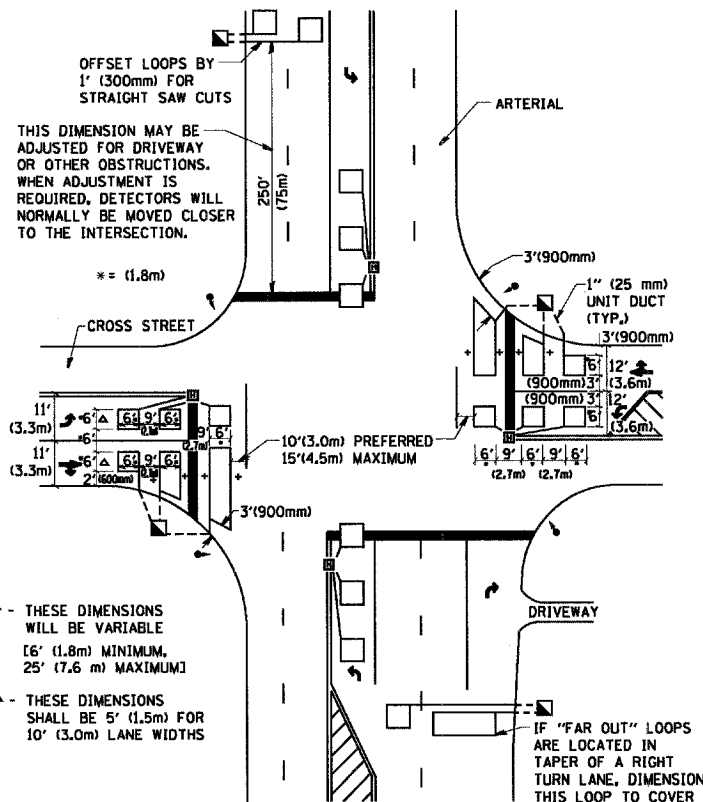

+ - THESE DIMENSIONS WILL BE VARIABLE [6' (1.8m) MINIMUM, 25' (7.6 m) MAXIMUM]
- THESE DIMENSIONS SHALL BE 5' (1.5m) FOR 10' (3.0m) LANE WIDTHS

DETAIL 2
N.T.S.

NOTES:

VEHICLES LOOP DETECTORS

- * ALL LEAD IN CABLE SHALL BE TWO CONDUCTOR NO. 14 TWISTED, SHIELDED.
- * EACH DETECTOR LOOP SHALL HAVE ITS OWN SAW CUT FROM THE LOOP TO THE EDGE OF PAVEMENT OR TO A HANDHOLE IN THE PAVEMENT.
- * EACH DETECTOR LOOP SHALL HAVE ITS OWN ONE INCH (25 mm) UNIT DUCT BETWEEN THE EDGE OF PAVEMENT AND THE FIRST HANDHOLE OR JUNCTION BOX. EACH UNIT DUCT RUN SHALL BE SHOWN ON THE PLANS BY THE DESIGNER, BUT SHALL NOT BE PAID FOR SEPARATELY. THIS ITEM IS INCIDENTAL TO THE PAY ITEM FOR DETECTOR LOOPS.
- * ONE DIMENSION OF ALL DETECTOR LOOPS SHALL BE SIX FEET (1.8 m)
- * EACH LANE OF NON-LOCKING, PRESENCE DETECTION AND EACH LANE OF A DOUBLE LEFT TURN LANE REQUIRES A SEPARATE INDUCTIVE LOOP DETECTOR AND LEAD IN CABLE.
- * WHEN NON-LOCKING, PRESENCE DETECTION IS USED, MORE THAN ONE LOOP PER LANE IS REQUIRED BEHIND THE STOP BAR (i.e. 1-1/2, 1-3/4, 2).
- * WHEN SYSTEM LOOPS ARE REQUIRED ON AN APPROACH OF AN INTERSECTION, THE LOOPS USED FOR VOLUME DENSITY AND INTERSECTION TIMING SHALL ALSO BE USED AS SYSTEM DETECTORS. EACH ONE OF THESE TYPE OF LOOPS REQUIRES A SEPARATE TWO CONDUCTOR NO. 14 TWISTED SHIELDED CABLE AND A SEPARATE INDUCTIVE LOOP DETECTOR WHEN NEW CONTROLLERS ARE UTILIZED. THE DESIGNER SHALL LABEL THESE TYPES OF LOOPS AS "INTERSECTION AND SAMPLING (SYSTEM) DETECTORS" ON THE SIGNAL LAYOUT, THE INTERCONNECT PLAN AND THE SYSTEM CABLE PLAN. WHEN AN EXISTING CONTROLLER IS UTILIZED FOR THIS TYPE OF DETECTION, THE PAY ITEM "INDUCTIVE LOOP DETECTOR WITH SYSTEM OUTPUT" SHOULD BE USED.

PLACEMENT OF DETECTORS

THE FOLLOWING FIGURES REPRESENT THE MOST COMMON DETECTOR LOOP LOCATIONS AND SIZES. ADJUSTMENTS WILL BE NECESSARY FOR SPECIFIC GEOMETRIC CONSIDERATIONS.

LOCATIONS AND DEMENSIONS OF DETECTOR LOOPS ARE REQUIRED ON ALL SIGNAL LAYOUT PLAN SHEETS.

"FAR OUT" DETECTION REFERS TO LOCKING, PRESENCE TYPE DETECTION LOCATED IN THRU LANES, RIGHT TURN LANES, AND RIGHT TURN LANE TAPER AREAS (IF APPLICABLE), USUALLY 250' (75 m) IN ADVANCE OF STOP BARS. "UPTIGHT" DETECTION REFERS TO NON-LOCKING PRESENCE TYPE DETECTION LOCATED IN ALL LANES AND 10'-15' (3.0 m-4.5 m) BEHIND THE CROSSING STREET'S EDGE OF PAVEMENT EXTENDED.

NOTE:

ALL DETAILS AND NOTES SHOWN ARE FROM THE I.D.O.T. DISTRICT 1 TRAFFIC SIGNAL DESIGN GUIDELINES DATED JANUARY 1995

THIS DRAWING HAS BEEN PREPARED TO ASSIST THE RESIDENT ENGINEER FOR ALL ROADWAY RESURFACING OR S.M.A.R.T. PROJECTS WHERE THE DIMENSIONS ARE NOT SHOWN ON THE PLANS AND THE FINAL LOCATIONS FOR CROSSWALKS OR STOP BARS ARE NOT DETERMINED.

4/18/2008
K:\112259505\Drawings\112259505.DIST1\TALL.dgn
Jmerston
TS27

FILE NAME = W:\dist1\std\22x34\ts07.dgn	USER NAME = gaglianob	DESIGNED - DRAWN -	REVISED - REVISED -	STATE OF ILLINOIS DEPARTMENT OF TRANSPORTATION	DISTRICT 1 - DETECTOR LOOP INSTALLATION DETAILS FOR ROADWAY RESURFACING	F.A.P. RTE. 344	SECTION 3034 RS-4	COUNTY COOK	TOTAL SHEETS 21	SHEET NO. 21
PLOT SCALE = 50.0000' / IN.	PLOT DATE = 1/4/2008	CHECKED - DATE	REVISED - REVISED -	SCALE: NONE	SHEET NO. 1 OF 1 SHEETS	STA. TO STA.	CONTRACT NO. 60E30		FED. ROAD DIST. NO. 1 ILLINOIS FED. AID PROJECT	