

IL 19 (IRVING PARK RD)

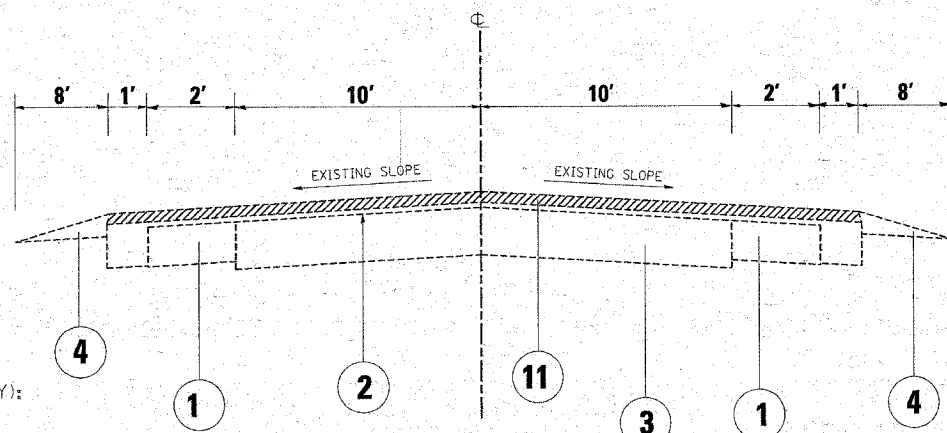

NOTE (LT SIDE ONLY):
 8' HMA SHOULDER
 STA. 105+00 TO STA. 106+06

EXISTING TYPICAL CROSS SECTION
 STA. 88+88 TO STA. 105+00
 STA. 105+00 TO STA. 106+02

IL 19 (IRVING PARK RD)

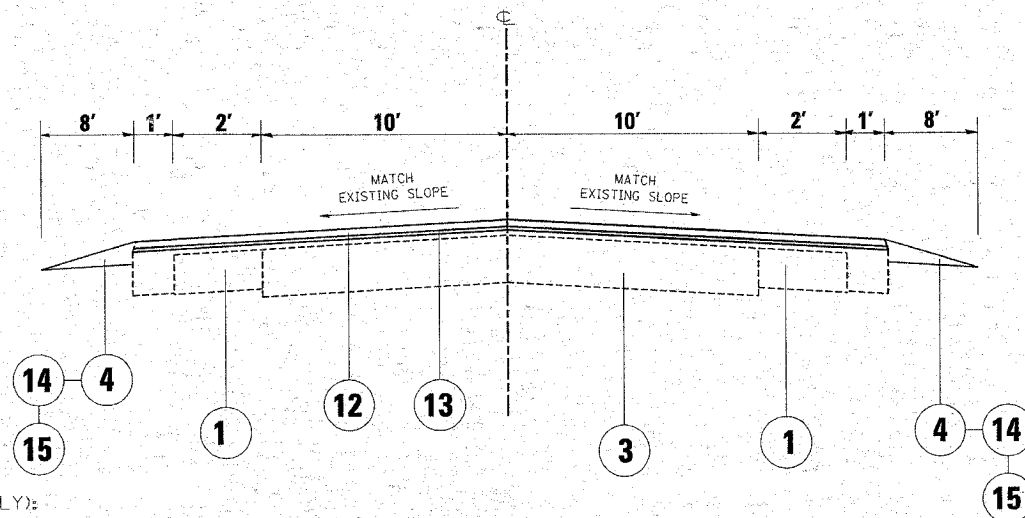

NOTE (LT SIDE ONLY):
 8' HMA SHOULDER
 STA. 105+00 TO STA. 106+06

PROPOSED TYPICAL CROSS SECTION
 STA. 88+88 TO STA. 105+00
 STA. 105+00 TO STA. 106+02

LEGEND

- ① EXISTING HMA CONCRETE WIDENING, 8-10"
- ② EXISTING HMA CONCRETE OVERLAY, VARIES 3-6"
- ③ EXISTING PORTLAND CEMENT CONCRETE 9"-7"-9"
- ④ EXISTING AGGREGATE WEDGE SHOULDER, TYPE B
- ⑤ EXISTING HMA SHOULDER
- ⑥ EXISTING SUB-BASE GRANULAR MATERIAL
- ⑦ EXISTING POROUS GRANULAR EMBANKMENT
- ⑧ EXISTING CONCRETE CURB AND GUTTER, TYPE B-6.12
- ⑨ EXISTING CONCRETE CURB AND GUTTER, TYPE B-6.24
- ⑩ EXISTING PORTLAND CEMENT CONCRETE SIDEWALK, 5"
- ⑪ PROP. HMA SURFACE REMOVAL, 2 1/4"
- ⑫ PROP. HMA SURFACE COURSE, MIX "D" N70, 1-1/2"
- ⑬ PROP. POLYMERIZED LEVELING BINDER (MACHINE METHOD), IL-4.75, N50, 3/4"
- ⑭ PROP. AGGREGATE WEDGE SHOULDERS, TYPE B
- ⑮ PROP. GRADING & SHAPING SHOULDERS
- ⑯ PROP. COMB. CURB & GUTTER REMOVAL & REPLACEMENT (LOCATIONS TO BE DETERMINED BY THE ENGINEER)
- ⑰ PROP. SIDEWALK REMOVAL & REPLACEMENT (LOCATIONS TO BE DETERMINED BY THE ENGINEER)

HOT-MIX ASPHALT MIXTURE REQUIREMENTS

THE FOLLOWING MIXTURE REQUIREMENTS ARE APPLICABLE FOR THIS PROJECT.

MIXTURE TYPE	AC/PG	AIR VOIDS (%)	THICKNESS
PAVEMENT RESURFACING			
POLYMERIZED LEVELING BINDER (MACHINE METHOD), IL-4.75, N50	SBS/SBR PG 76-28/-22	4% @ 50 GYR	3/4"
HOT-MIX ASPHALT SURFACE COURSE, MIX "D", N70 (IL 9.5 mm)	PG 64-22	4% @ 70 GYR	1-1/2"
HOT-MIX ASPHALT PATCHING			
CLASS D PATCHES (HMA BINDER IL-19 mm)	PG 64-22 *	4% @ 70 GYR	10"
HMA REPLACEMENT OVER PATCHES (HMA BINDER IL-19 mm)	PG 64-22 *	4% @ 70 GYR	6"

NOTE:

THE UNIT WEIGHT USED TO CALCULATE ALL HMA SURFACE MIXTURE QUANTITIES IS 112 POUNDS PER SQUARE YARD PER INCH.

* WHEN RAP EXCEEDS 20%, THE NEW ASPHALT BINDER IN THE MIX SHALL BE PG 58-22

FOR DRIVEWAY REMOVAL AND REPLACEMENT REFER TO DRIVEWAY DETAILS ON SHEET NO. 26B & 26C

REVISIONS		ILLINOIS DEPARTMENT OF TRANSPORTATION ILLINOIS ROUTE 19 (IRVING PARK ROAD) WO MITCHELL BLVD. TO BAKER DR. EXISTING AND PROPOSED TYPICAL SECTIONS
NAME	DATE	
SCALE:	VERT. DRAWN BY	CHECKED BY
	HORIZ.	
DATE		