

F.A.U. RTE.	SECTION	COUNTY	TOTAL SHEETS	SHEET NO.
1321	(31&72S)RS-8	DUPAGE	37	1
			+3	
			40	

STATE OF ILLINOIS
DEPARTMENT OF TRANSPORTATION
DIVISION OF HIGHWAYS

**PROPOSED
HIGHWAY PLANS**

**FAU ROUTE 1321: IL RTE. 19 (IRVING PARK RD.)
W/O MITCHELL BLVD. TO BAKER DR.
SECTION (31 & 72S) RS-8
RESURFACING (MAINTENANCE)
PROJECT NO.: ACM-1321(017)
DUPAGE COUNTY
C-91-085-04**

FOR INDEX OF SHEETS, SEE SHEET NO. 2

THE IMPROVEMENT IS LOCATED
IN THE VILLAGE OF ROSELLE

AVERAGE DAILY TRAFFIC = 17,700
POSTED SPEED LIMIT = 30-40 MPH

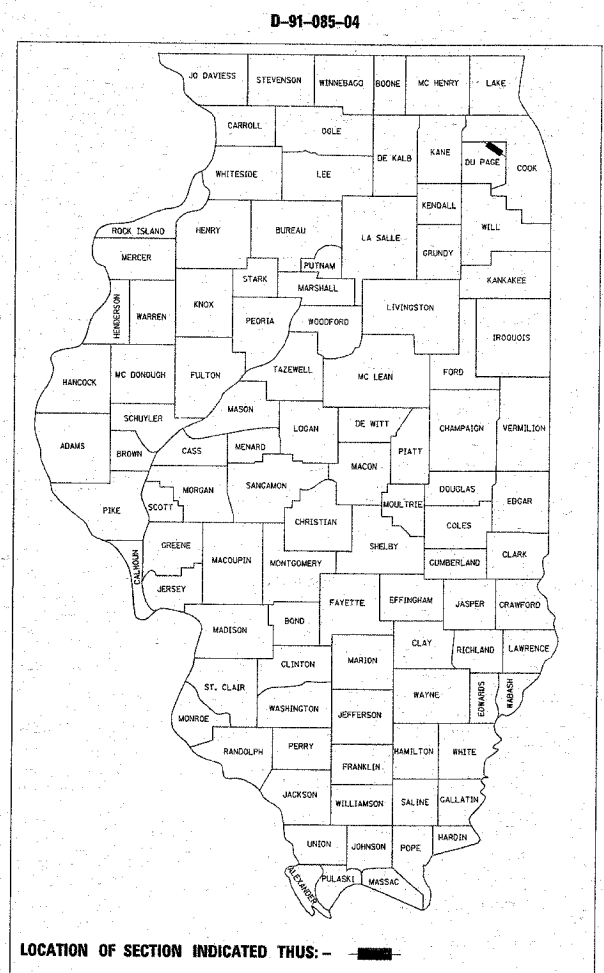

DISTRICT ONE - DESIGN AND PLAN PREPARATION ENGINEER: K. ENG / J.P. CHANG (847) 705 - 4432

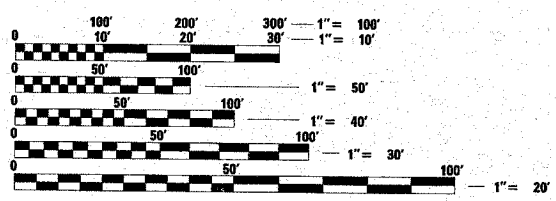

FULL SIZE PLANS HAVE BEEN PREPARED USING STANDARD ENGINEERING SCALES. REDUCED SIZED PLANS WILL NOT CONFORM TO STANDARD SCALES. IN MAKING MEASUREMENTS ON REDUCED PLANS, THE ABOVE SCALES MAY BE USED.

J.U.L.I.E.
JOINT UTILITY LOCATION INFORMATION FOR EXCAVATION
1-800-892-0123 OR 811

CONTRACT NO. 62703

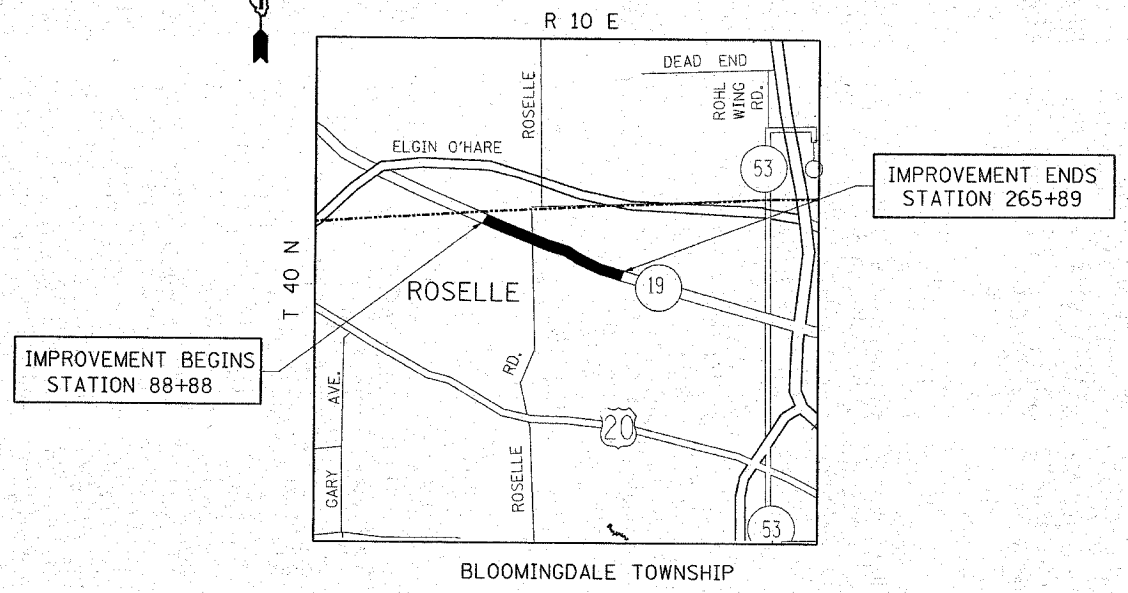

GROSS AND NET LENGTH OF IMPROVEMENT = 17,701 LINEAL FEET = 3.35 MILES

STATE OF ILLINOIS
DEPARTMENT OF TRANSPORTATION
DIVISION OF HIGHWAYS

SUBMITTED March 25, 2008

Dina Oll
DEPUTY DIRECTOR OF HIGHWAYS, REGION ENGINEER

May 9, 2008
Eric E. Haran
ENGINEER OF DESIGN AND ENVIRONMENT

May 9, 2008
Christine M. Reed
DIRECTOR OF HIGHWAYS, CHIEF ENGINEER

**PRINTED BY THE AUTHORITY
OF THE STATE OF ILLINOIS**

F.A.U. RTE.	SECTION	COUNTY	TOTAL SHEETS	SHEET NO.
1321	(31&72)RS-8	DUPAGE	37	2
FED. ROAD DIST. NO.	ILLINOIS	FED. AID PROJECT		

CONTRACT NO. 62703

INDEX OF SHEETS

SHEET NO.	DESCRIPTION
1	TITLE SHEET
2	INDEX OF SHEETS, STATE STANDARDS, AND GENERAL NOTES
3-4	SUMMARY OF QUANTITIES
5-14	EXISTING AND PROPOSED TYPICAL SECTIONS
15-21	ROADWAY AND PAVEMENT MARKING PLANS
22-26	DETECTOR LOOPS REPLACEMENT PLANS
26A	OUTLET FOR CONCRETE CURB AND GUTTER
26B	DRIVEWAY DETAILS DISTANCE BETWEEN R.O.W. AND FACE OF CURB & EDGE OF SHOULDER $\geq 15'$ (4.5 m)
26C	DRIVEWAY DETAILS DISTANCE BETWEEN R.O.W. AND FACE OF CURB $< 15'$ (4.5 m)
27	DETAILS FOR FRAMES AND LIDS ADJUSTMENT WITH MILLING
28	PAVEMENT PATCHING FOR HMA SURFACED PAVEMENT
29	CURB OR CURB AND GUTTER REMOVAL AND REPLACEMENT
30	BUTT JOINT AND HMA TAPER DETAILS
31	TRAFFIC CONTROL AND PROTECTION FOR SIDE ROADS, INTERSECTIONS, AND DRIVEWAYS
32	TYPICAL APPLICATIONS: RAISED REFLECTIVE PAVEMENT MARKERS (SNOW-PLOW RESISTANT)
33	DISTRICT ONE TYPICAL PAVEMENT MARKINGS
34	TRAFFIC CONTROL AND PROTECTION OF TURN BAYS (TO REMAIN OPEN TO TRAFFIC)
35	PAVEMENT MARKING LETTERS AND SYMBOLS FOR TRAFFIC STAGING
36	DISTRICT 1 DETECTOR LOOP INSTALLATION DETAILS FOR ROADWAY RESURFACING
37	ARTERIAL ROAD INFORMATION SIGN

STATE STANDARDS:

000001-05	STANDARD SYMBOLS, ABBREVIATIONS, AND PATTERNS
420001-07	PAVEMENT JOINTS
424001-05	CURB RAMPS ACCESSIBLE TO THE DISABLED
442201-03	CLASS C AND D PATCHES
482011-03	HMA SHLD STRIPS/SHLDS. WITH RESURFACING OR WIDENING AND RESURFACING PROJECTS
604001-02	FRAME AND LIDS, TYPE 1
606001-03	CONCRETE CURB TYPE B AND COMBINATION CONCRETE CURB AND GUTTER
606006-01	OUTLETS FOR CONCRETE CURB & GUTTER, TYPE B-6.24
630001-07	STEEL PLATE BEAM GUARDRAIL
630201-05	PCC/HMA STABILIZATION AT STEEL PLATE BEAM GUARDRAIL
630301-04	SHOULDER WIDENING FOR TYPE I (SPECIAL) GUARDRAIL TERMINALS
635001	
635006-02	REFLECTOR AND TERMINAL MARKER PLACEMENT
701301-02	LANE CLOSURE, 2L, 2W SHORT TIME OPERATIONS
701311-02	LANE CLOSURE 2L, 2W MOVING OPERATIONS-DAY ONLY
701501-04	URBAN LANE CLOSURE, 2L, 2W, UNDIVIDED
701606-05	URBAN LANE CLOSURE MULTILANE 2-W WITH MOUNTABLE MEDIAN
701701-05	URBAN LANE CLOSURE MULTILANE INTERSECTION
701801-03	LANE CLOSURE, MULTILANE, 1W OR 2W, CROSSWALK OR SIDEWALK CLOSURE
701901	TRAFFIC CONTROL DEVICES
886001	DETECTOR LOOP INSTALLATIONS

NOTE:

CLASS SI CONCRETE (OUTLET) STA. 228 + 50 TO STA. 229 + 12 (RT)
ALL CONSTRUCTION, EXCAVATION AND RESTORATION WILL BE PAID FOR AT THE CONTRACT UNIT PRICE PER CUBIC YARD FOR CLASS SI CONCRETE (OUTLET).

GENERAL NOTES:

BEFORE STARTING ANY EXCAVATION, THE CONTRACTOR SHALL CALL "JULIE" AT 800-892-0123 FOR FIELD LOCATIONS OR BURIED ELECTRIC, TELEPHONE, AND GAS FACILITIES. (48 HOUR NOTIFICATION REQUIRED)

THE CONTRACTOR SHALL COORDINATE CONSTRUCTION ACTIVITIES WITH UTILITY COMPANIES AND THE VILLAGE OF ROSELLE.

THE CONTRACTOR WILL NOT BE ALLOWED TO SET UP A YARD OR FIELD OFFICE ON STATE PROPERTY WITHOUT THE WRITTEN PERMISSION OF THE DEPARTMENT.

ALL HMA PAVEMENT PATCHING SHALL BE CLASS D.

BUTT JOINTS WILL BE INSTALLED AT THE ENDS OF RESURFACING (WHERE RESURFACING MEETS EXISTING PAVEMENT). IN ACCORDANCE WITH THE "BUTT JOINT AND HMA TAPER DETAILS" SHEET INCLUDED IN THE PLANS UNLESS OTHERWISE SPECIFIED.

10 FEET (3 METER) TRANSITION SHALL BE USED TO MATCH PROPOSED CURB AND GUTTER TO EXISTING CURB AND GUTTERS IN THE FIELD, UNLESS OTHERWISE SHOWN. THE TRANSITION SHALL BE PAID FOR AT THE CONTRACT UNIT PRICE FOR THE PROPOSED ITEMS OF WORK SPECIFIED.

WHEN MILLED PAVEMENT IS OPEN TO TRAFFIC, THE MAXIMUM GRADE DIFFERENTIAL BETWEEN PASSES OF THE MILLING MACHINE SHALL NOT EXCEED 1/2 INCHES WHERE THE SPEED LIMIT IS 45 MPH OR LESS, AND 1 INCH WHERE THE SPEED LIMIT IS 45 MPH. WITH WRITTEN APPROVAL FROM THE RESIDENT ENGINEER, A MAXIMUM GRADE DIFFERENTIAL OF 3 INCHES MAY BE ALLOWED IF THE EDGE OF THE MILLING IS SLOPED A MINIMUM OF 1:3 (V:H)

THE CONTRACTOR SHALL CONTACT DISTRICT ONE TRAFFIC CONTROL SUPERVISOR AT (847) 705 - 4470 A MINIMUM OF 72 HOURS IN ADVANCE OF BEGINNING WORK.

THE RESIDENT ENGINEER SHALL VERIFY THE LOCATIONS OF ALL EXISTING PAVEMENT MARKINGS PRIOR TO MILLING AND RESURFACING.

THE CONTRACTOR SHALL BE REQUIRED TO PROVIDE ACCESS TO ADJUTING PROPERTY AT ALL TIMES DURING THE CONSTRUCTION OF THIS PROJECT.

THE RESIDENT ENGINEER SHALL CONTACT MR. DON CHIARUGI, AREA TRAFFIC FIELD ENGINEER, AT (847) 741-9857 A MINIMUM OF 72 HOURS PRIOR TO PLACEMENT OF PERMANENT PAVEMENT MARKINGS.

REVISIONS	
NAME	DATE

ILLINOIS DEPARTMENT OF TRANSPORTATION
**ILLINOIS ROUTE 19 (IRVING PARK ROAD)
 WO MITCHELL BLVD. TO BAKER DR.**
**INDEX OF SHEETS, STATE STANDARDS,
 AND GENERAL NOTES**
 SCALE: VERT. DRAWN BY
 DATE 4/2/2008 CHECKED BY

Rev.

CONTRACT NO. 62703

SUMMARY OF QUANTITIES			URBAN 80% FED. 20% STATE					CONSTRUCTION TYPE CODE				
CODE NO	ITEM	UNIT	TOTAL QUANTITIES	1000-2A								
20201006	GRADING AND SHAPING SHOULDERS	UNIT	168	168								
40600200	BITUMINOUS MATERIALS (PRIME COAT)	TON	34	34								
40600300	AGGREGATE (PRIME COAT)	TON	162	162								
40600400	MIXTURE FOR CRACKS, JOINTS, AND FLANGEWAYS	TON	10	10								
40600895	CONSTRUCTING TEST STRIP	EACH	2	2								
40600982	HOT-MIX ASPHALT SURFACE REMOVAL - BUTT JOINT	SO YD	497	497								
40601005	HOT-MIX ASPHALT REPLACEMENT OVER PATCHES	TON	1481	1481								
40603340	HOT-MIX ASPHALT SURFACE COURSE, MIX "D", N70	TON	6986	6986								
42001300	PROTECTIVE COAT	SO YD	437	437								
44000158	HOT-MIX ASPHALT SURFACE REMOVAL, 2 1/4"	SO YD	80738	80738								
44001700	COMBINATION CONCRETE CURB AND GUTTER REMOVAL AND REPLACEMENT	FOOT	1800	1800								
44002224	HOT-MIX ASPHALT REMOVAL OVER PATCHES, 6"	SO YD	4280	4280								
44004610	SIDEWALK REMOVAL AND REPLACEMENT (SPECIAL)	SO FT	280	280								
44201761	CLASS D PATCHES, TYPE I, 10 INCH	SO YD	100	100								
44201765	CLASS D PATCHES, TYPE II, 10 INCH	SO YD	2032	2032								
44201769	CLASS D PATCHES, TYPE III, 10 INCH	SO YD	936	936								
44201771	CLASS D PATCHES, TYPE IV, 10 INCH	SO YD	1212	1212								
48102100	AGGREGATE WEDGE SHOULDERS, TYPE B	TON	1424	1424								
# 55039700	STORM SEWERS TO BE CLEANED	FOOT	1500	1500								
60250200	CATCH BASINS TO BE ADJUSTED	EACH	6	6								
60251730	CATCH BASINS TO BE ADJUSTED WITH NEW TYPE 23 FRAME AND GRATE	EACH	4	4								
60251740	CATCH BASINS TO BE ADJUSTED WITH NEW TYPE 24 FRAME AND GRATE	EACH	16	16								
60254330	CATCH BASINS TO BE RECONSTRUCTED WITH NEW TYPE 23 FRAME AND GRATE	EACH	2	2								
60254340	CATCH BASINS TO BE RECONSTRUCTED WITH NEW TYPE 24 FRAME AND GRATE	EACH	9	9								
60260100	INLETS TO BE ADJUSTED	EACH	2	2								
60261530	INLETS TO BE ADJUSTED WITH NEW TYPE 23 FRAME AND GRATE	EACH	2	2								
60261540	INLETS TO BE ADJUSTED WITH NEW TYPE 24 FRAME AND GRATE	EACH	7	7								

SUMMARY OF QUANTITIES			URBAN 80% FED. 20% STATE					CONSTRUCTION TYPE CODE				
CODE NO	ITEM	UNIT	TOTAL QUANTITIES	1000-2A								
60300310	FRAMES AND LIDS TO BE ADJUSTED (SPECIAL)	EACH	48	48								
60600095	CLASS SI CONCRETE (OUTLET)	CU YD	3.5	3.5								
* 63000000	STEEL PLATE BEAM GUARD RAIL, TYPE A	FOOT	200	200								
* 63100167	TRAFFIC BARRIER TERMINAL, TYPE 1 (SPECIAL) TANGENT	EACH	12	12								
63200310	GUARDRAIL REMOVAL	FOOT	775	775								
67000400	ENGINEER'S FIELD OFFICE, TYPE A	CAL MO	6	6								
67100100	MOBILIZATION	L SUM	1	1								
70102620	TRAFFIC CONTROL AND PROTECTION, STANDARD 701501	L SUM	1	1								
70102625	TRAFFIC CONTROL AND PROTECTION, STANDARD 701606	L SUM	1	1								
70102635	TRAFFIC CONTROL AND PROTECTION, STANDARD 701701	L SUM	1	1								
70102640	TRAFFIC CONTROL AND PROTECTION, STANDARD 701801	L SUM	1	1								
70103815	TRAFFIC CONTROL SURVEILLANCE	CAL DA	40	40								
70300100	SHORT-TERM PAVEMENT MARKING	FOOT	20766	20766								
70300210	TEMPORARY PAVEMENT MARKING - LETTERS AND SYMBOLS	SO FT	797	797								
70300220	TEMPORARY PAVEMENT MARKING - LINE 4"	FOOT	56710	56710								
70300240	TEMPORARY PAVEMENT MARKING - LINE 6"	FOOT	4598	4598								
70300260	TEMPORARY PAVEMENT MARKING - LINE 12"	FOOT	601	601								
70300280	TEMPORARY PAVEMENT MARKING - LINE 24"	FOOT	957	957								
70301000	WORK ZONE PAVEMENT MARKING REMOVAL	SO FT	30970	30970								
* 78000100	THERMOPLASTIC PAVEMENT MARKING - LETTERS AND SYMBOLS	SO FT	797	797								
* 78000200	THERMOPLASTIC PAVEMENT MARKING - LINE 4"	FOOT	56710	56710								
* 78000400	THERMOPLASTIC PAVEMENT MARKING - LINE 6"	FOOT	4598	4598								
* 78000600	THERMOPLASTIC PAVEMENT MARKING - LINE 12"	FOOT	601	601								

* SPECIALTY ITEMS
NON PARTICIPATING ITEMS

REVISIONS	
NAME	DATE

ILLINOIS DEPARTMENT OF TRANSPORTATION
ILLINOIS ROUTE 19 (IRVING PARK ROAD)
W/O MITCHELL BLVD. TO BAKER DR.
SUMMARY OF QUANTITIES

PLOT DATE: 4/2/2008

4/2/2008
C:\pccollect\4109549\1321\1321.dwg

CONTRACT NO. 62703

SUMMARY OF QUANTITIES			CONSTRUCTION TYPE CODE					SUMMARY OF QUANTITIES			CONSTRUCTION TYPE CODE													
CODE NO	ITEM	UNIT	TOTAL QUANTITIES						CODE NO	ITEM	UNIT	TOTAL QUANTITIES												
				1000-2A																				
* 78000650	THERMOPLASTIC PAVEMENT MARKING - LINE 24"	FOOT	957	957																				
* 78100100	RAISED REFLECTIVE PAVEMENT MARKER	EACH	912	912																				
* 78201000	TERMINAL MARKER - DIRECT APPLIED	EACH	12	12																				
78300200	RAISED REFLECTIVE PAVEMENT MARKER REMOVAL	EACH	1089	1089																				
* 88600600	DETECTOR LOOP REPLACEMENT	FOOT	3345	3345																				
X0322256	TEMPORARY INFORMATION SIGNING	SQ FT	51.4	51.4																				
X0323095	TYPE 1 FRAME, CLOSED LID	EACH	8	8																				
X0656100	DRIVEWAY PAVEMENT REMOVAL AND REPLACEMENT	SQ YD	1120	1120																				
X4067107	POLYMERIZED LEVELING BINDER (MACHINE METHOD), IL-4.75, N50	TON	3493	3493																				
# Z0018500	DRAINAGE STRUCTURES TO CLEANED	EACH	48	48																				
Z0048665	RAILROAD PROTECTIVE LIABILITY INSURANCE	L SUM	1	1																				
Ⓞ Z0076600	TRAINEES	HOUR	2000	2000																				

Ⓞ Y080
* SPECIALTY ITEMS
NON PARTICIPATING ITEMS

REVISIONS	
NAME	DATE

ILLINOIS DEPARTMENT OF TRANSPORTATION
ILLINOIS ROUTE 19 (IRVING PARK ROAD)
WO MITCHELL BLVD. TO BAKER DR.
SUMMARY OF QUANTITIES

PLOT DATE: 4/2/2008

4/2/2008

IL 19 (IRVING PARK RD)

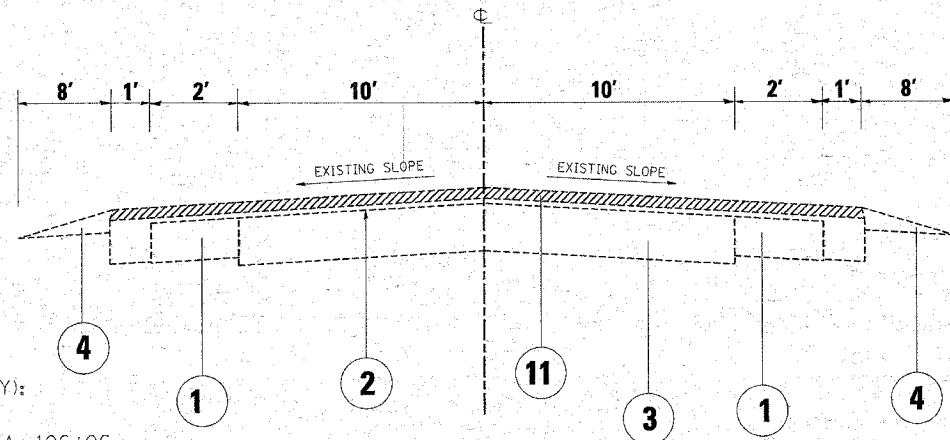

NOTE (LT. SIDE ONLY):
8' HMA SHOULDER
STA. 105+00 TO STA. 106+06

EXISTING TYPICAL CROSS SECTION
STA. 88+88 TO STA. 105+00
STA. 105+00 TO STA. 106+02

IL 19 (IRVING PARK RD)

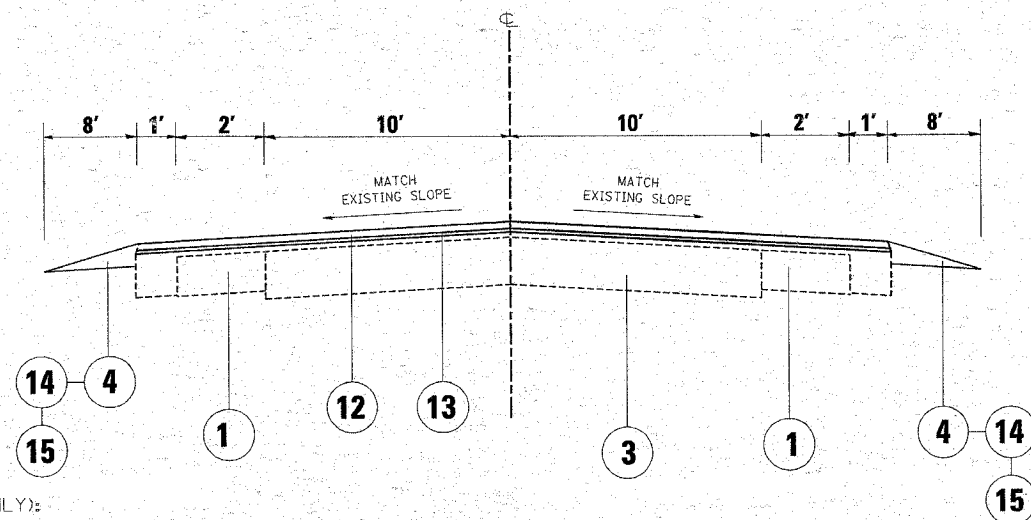

NOTE (LT. SIDE ONLY):
8' HMA SHOULDER
STA. 105+00 TO STA. 106+06

PROPOSED TYPICAL CROSS SECTION
STA. 88+88 TO STA. 105+00
STA. 105+00 TO STA. 106+02

LEGEND

- ① EXISTING HMA CONCRETE WIDENING, 8-10"
- ② EXISTING HMA CONCRETE OVERLAY, VARIES 3-6"
- ③ EXISTING PORTLAND CEMENT CONCRETE 9"-7"-9"
- ④ EXISTING AGGREGATE WEDGE SHOULDER, TYPE B
- ⑤ EXISTING HMA SHOULDER
- ⑥ EXISTING SUB-BASE GRANULAR MATERIAL
- ⑦ EXISTING POROUS GRANULAR EMBANKMENT
- ⑧ EXISTING CONCRETE CURB AND GUTTER, TYPE B-6.12
- ⑨ EXISTING CONCRETE CURB AND GUTTER, TYPE B-6.24
- ⑩ EXISTING PORTLAND CEMENT CONCRETE SIDEWALK, 5"
- ⑪ PROP. HMA SURFACE REMOVAL, 2 1/4"
- ⑫ PROP. HMA SURFACE COURSE, MIX "D" N70, 1-1/2"
- ⑬ PROP. POLYMERIZED LEVELING BINDER (MACHINE METHOD), IL-4.75, N50, 3/4"
- ⑭ PROP. AGGREGATE WEDGE SHOULDERS, TYPE B
- ⑮ PROP. GRADING & SHAPING SHOULDERS
- ⑯ PROP. COMB. CURB & GUTTER REMOVAL & REPLACEMENT (LOCATIONS TO BE DETERMINED BY THE ENGINEER)
- ⑰ PROP. SIDEWALK REMOVAL & REPLACEMENT (LOCATIONS TO BE DETERMINED BY THE ENGINEER)

HOT-MIX ASPHALT MIXTURE REQUIREMENTS

THE FOLLOWING MIXTURE REQUIREMENTS ARE APPLICABLE FOR THIS PROJECT.

MIXTURE TYPE	AC/PG	AIR VOIDS (%)	THICKNESS
PAVEMENT RESURFACING			
POLYMERIZED LEVELING BINDER (MACHINE METHOD), IL-4.75, N50	SBS/SBR PG 76-28/-22	4% @ 50 GYR	3/4"
HOT-MIX ASPHALT SURFACE COURSE, MIX "D", N70 (IL 9.5 mm)	PG 64-22	4% @ 70 GYR	1-1/2"
HOT-MIX ASPHALT PATCHING			
CLASS D PATCHES (HMA BINDER IL-19 mm)	PG 64-22 *	4% @ 70 GYR	10"
HMA REPLACEMENT OVER PATCHES (HMA BINDER IL-19 mm)	PG 64-22 *	4% @ 70 GYR	6"

NOTE:

THE UNIT WEIGHT USED TO CALCULATE ALL HMA SURFACE MIXTURE QUANTITIES IS 112 POUNDS PER SQUARE YARD PER INCH.

* WHEN RAP EXCEEDS 20%, THE NEW ASPHALT BINDER IN THE MIX SHALL BE PG 58-22

FOR DRIVEWAY REMOVAL AND REPLACEMENT REFER TO DRIVEWAY DETAILS ON SHEET NO. 26B & 26C

REVISIONS		ILLINOIS DEPARTMENT OF TRANSPORTATION ILLINOIS ROUTE 19 (IRVING PARK ROAD) WO MITCHELL BLVD. TO BAKER DR. EXISTING AND PROPOSED TYPICAL SECTIONS
NAME	DATE	
SCALE:	VERT. DRAWN BY	CHECKED BY
	HORIZ. DATE	

IL 19 (IRVING PARK RD)

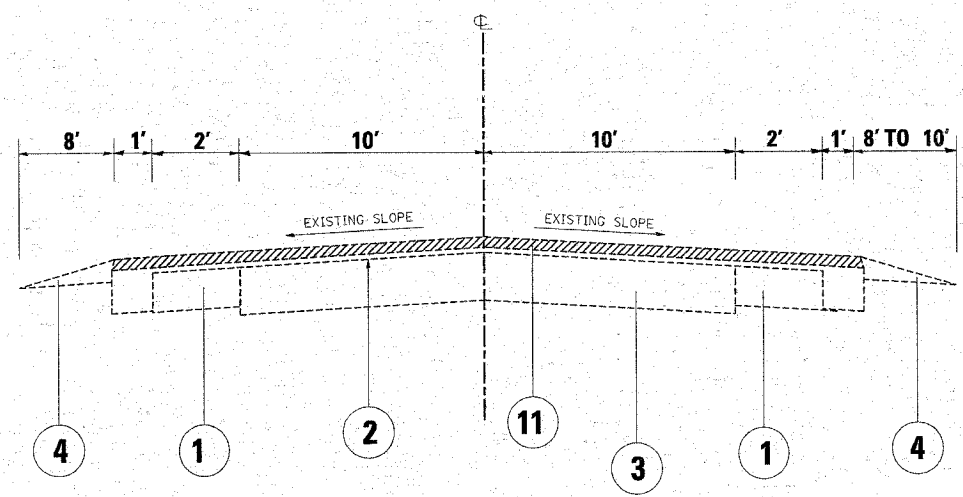

NOTE (RT SIDE ONLY):
 10' P.C.C. SHOULDER
 WITH B-6.12 C&G
 STA. 111+08 TO STA. 112+62

EXISTING TYPICAL CROSS SECTION
 STA. 106+02 TO STA. 106+40
 STA. 109+68 TO STA. 115+79

IL 19 (IRVING PARK RD)

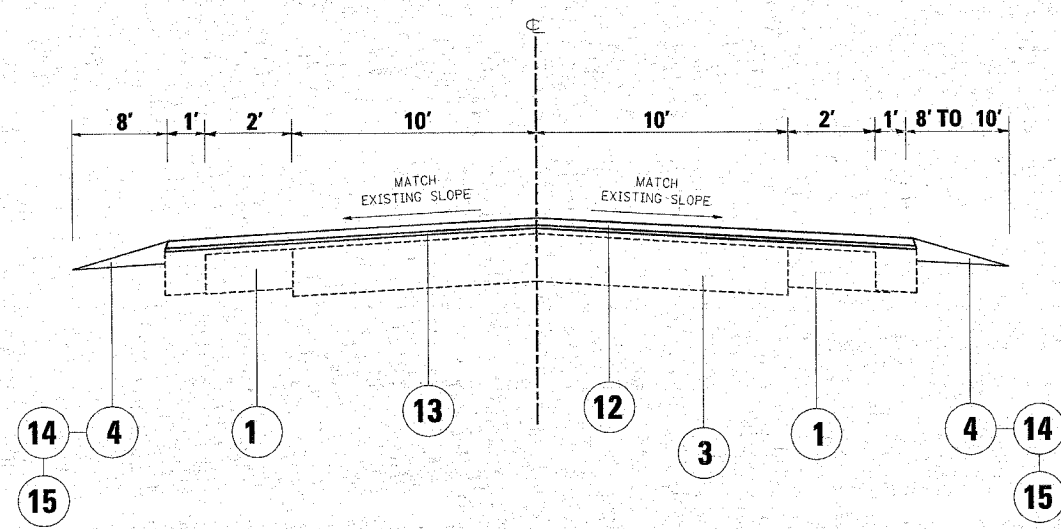

NOTE (RT SIDE ONLY):
 10' P.C.C. SHOULDER
 WITH B-6.12 C&G
 STA. 111+08 TO STA. 112+62

PROPOSED TYPICAL CROSS SECTION
 STA. 106+02 TO STA. 106+40
 STA. 109+68 TO STA. 115+79

LEGEND

- ① EXISTING HMA CONCRETE WIDENING, 8-10"
- ② EXISTING HMA CONCRETE OVERLAY, VARIES 3-6"
- ③ EXISTING PORTLAND CEMENT CONCRETE 9"-7"-9"
- ④ EXISTING AGGREGATE WEDGE SHOULDER, TYPE B
- ⑤ EXISTING HMA SHOULDER
- ⑥ EXISTING SUB-BASE GRANULAR MATERIAL
- ⑦ EXISTING POROUS GRANULAR EMBANKMENT
- ⑧ EXISTING CONCRETE CURB AND GUTTER, TYPE B-6.12
- ⑨ EXISTING CONCRETE CURB AND GUTTER, TYPE B-6.24
- ⑩ EXISTING PORTLAND CEMENT CONCRETE SIDEWALK, 5"
- ⑪ PROP. HMA SURFACE REMOVAL, 2 1/4"
- ⑫ PROP. HMA SURFACE COURSE, MIX "D" N70, 1-1/2"
- ⑬ PROP. POLYMERIZED LEVELING BINDER (MACHINE METHOD), IL-4.75, N50, 3/4"
- ⑭ PROP. AGGREGATE WEDGE SHOULDERS, TYPE B
- ⑮ PROP. GRADING & SHAPING SHOULDERS
- ⑯ PROP. COMB. CURB & GUTTER REMOVAL & REPLACEMENT (LOCATIONS TO BE DETERMINED BY THE ENGINEER)
- ⑰ PROP. SIDEWALK REMOVAL & REPLACEMENT (LOCATIONS TO BE DETERMINED BY THE ENGINEER)

REVISIONS	
NAME	DATE

ILLINOIS DEPARTMENT OF TRANSPORTATION
 ILLINOIS ROUTE 19 (IRVING PARK ROAD)
 WO MITCHELL BLVD. TO BAKER DR.
 EXISTING AND PROPOSED
 TYPICAL SECTIONS

SCALE: VERT. _____
 HORIZ. _____
 DATE _____

DRAWN BY _____
 CHECKED BY _____

IL 19 (IRVING PARK RD)

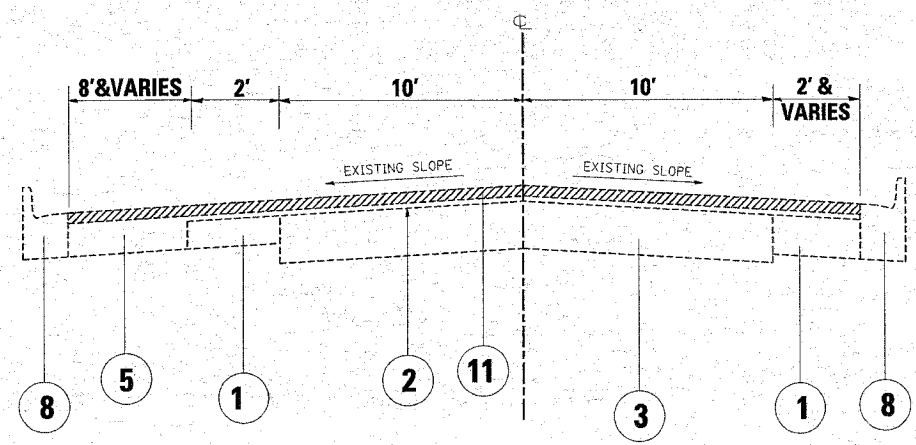

EXISTING TYPICAL CROSS SECTION
STA. 121+53 TO STA. 127+20

IL 19 (IRVING PARK RD)

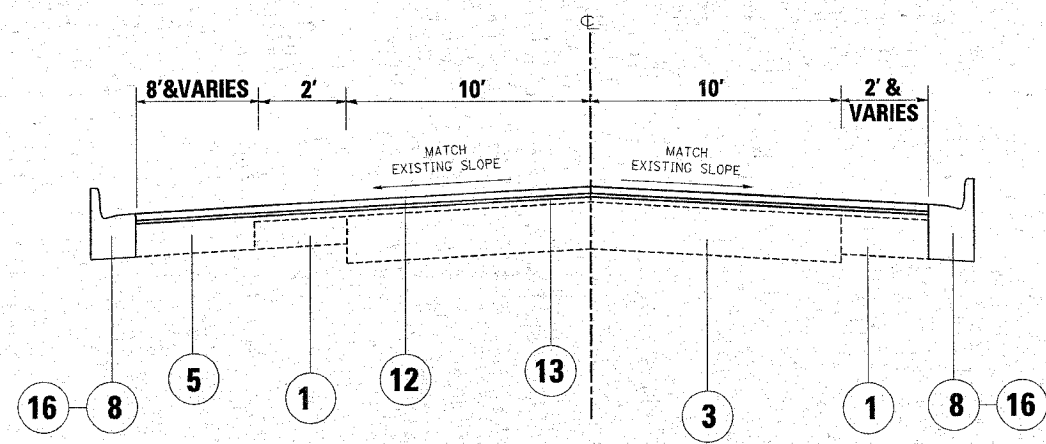

PROPOSED TYPICAL CROSS SECTION
STA. 121+53 TO STA. 127+20

LEGEND

- ① EXISTING HMA CONCRETE WIDENING, 8-10"
- ② EXISTING HMA CONCRETE OVERLAY, VARIES 3-6"
- ③ EXISTING PORTLAND CEMENT CONCRETE 9"-7"-9"
- ④ EXISTING AGGREGATE WEDGE SHOULDER, TYPE B
- ⑤ EXISTING HMA SHOULDER
- ⑥ EXISTING SUB-BASE GRANULAR MATERIAL
- ⑦ EXISTING POROUS GRANULAR EMBANKMENT
- ⑧ EXISTING CONCRETE CURB AND GUTTER, TYPE B-6.12
- ⑨ EXISTING CONCRETE CURB AND GUTTER, TYPE B-6.24
- ⑩ EXISTING PORTLAND CEMENT CONCRETE SIDEWALK, 5"
- ⑪ PROP. HMA SURFACE REMOVAL, 2 1/4"
- ⑫ PROP. HMA SURFACE COURSE, MIX "D" N70, 1-1/2"
- ⑬ PROP. POLYMERIZED LEVELING BINDER (MACHINE METHOD), IL-4.75, N50, 3/4"
- ⑭ PROP. AGGREGATE WEDGE SHOULDERS, TYPE B
- ⑮ PROP. GRADING & SHAPING SHOULDERS
- ⑯ PROP. COMB. CURB & GUTTER REMOVAL & REPLACEMENT (LOCATIONS TO BE DETERMINED BY THE ENGINEER)
- ⑰ PROP. SIDEWALK REMOVAL & REPLACEMENT (LOCATIONS TO BE DETERMINED BY THE ENGINEER)

REVISIONS	
NAME	DATE

ILLINOIS DEPARTMENT OF TRANSPORTATION
**ILLINOIS ROUTE 19 (IRVING PARK ROAD)
 W/O MITCHELL BLVD. TO BAKER DR.**
**EXISTING AND PROPOSED
 TYPICAL SECTIONS**

SCALE: VERT. _____
 HORIZ. _____
 DATE _____ DRAWN BY _____
 CHECKED BY _____

IL 19 (IRVING PARK RD)

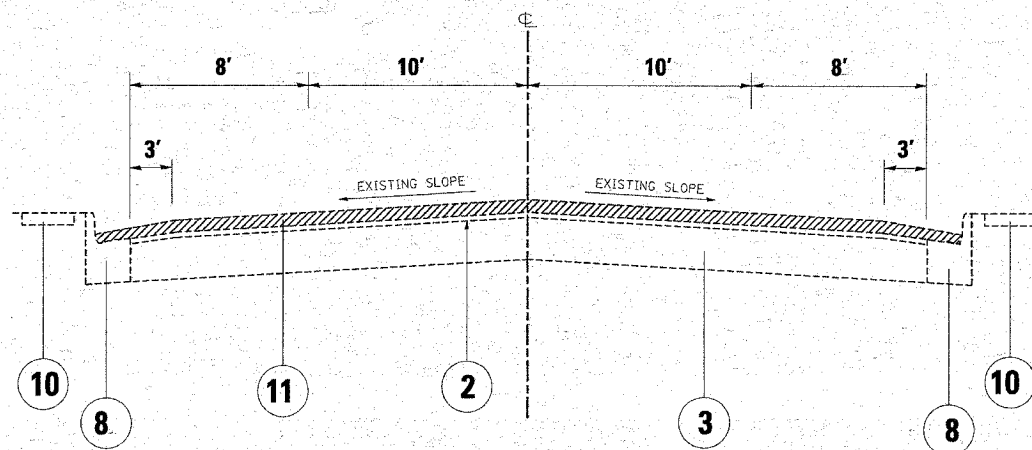

EXISTING TYPICAL CROSS SECTION
STA. 127+20 TO STA. 133+08

IL 19 (IRVING PARK RD)

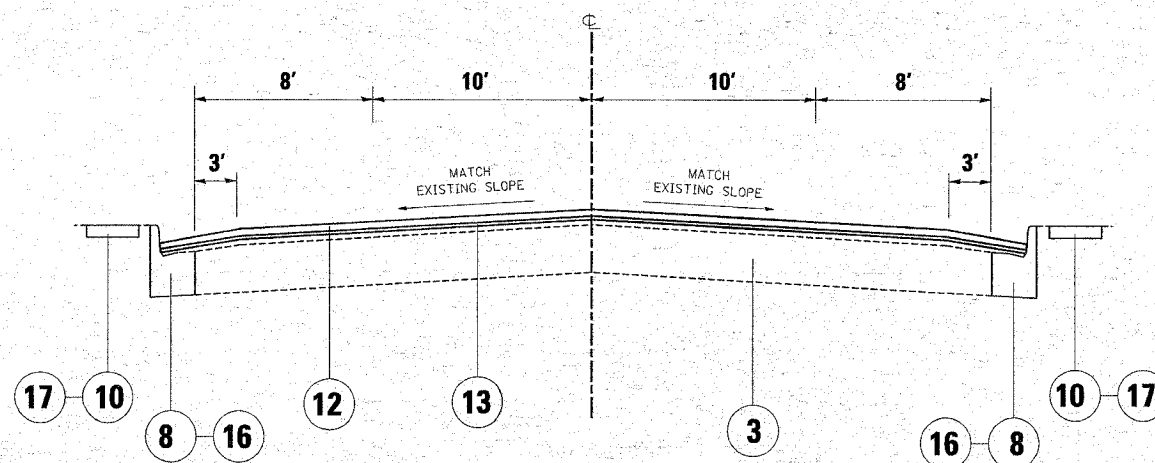

PROPOSED TYPICAL CROSS SECTION
STA. 127+20 TO STA. 133+08

LEGEND

- ① EXISTING HMA CONCRETE WIDENING, 8-10"
- ② EXISTING HMA CONCRETE OVERLAY, VARIES 3-6"
- ③ EXISTING PORTLAND CEMENT CONCRETE 9"-7"-9"
- ④ EXISTING AGGREGATE WEDGE SHOULDER, TYPE B
- ⑤ EXISTING HMA SHOULDER
- ⑥ EXISTING SUB-BASE GRANULAR MATERIAL
- ⑦ EXISTING POROUS GRANULAR EMBANKMENT
- ⑧ EXISTING CONCRETE CURB AND GUTTER, TYPE B-6.12
- ⑨ EXISTING CONCRETE CURB AND GUTTER, TYPE B-6.24
- ⑩ EXISTING PORTLAND CEMENT CONCRETE SIDEWALK, 5"
- ⑪ PROP. HMA SURFACE REMOVAL, 2 1/4"
- ⑫ PROP. HMA SURFACE COURSE, MIX "D" N70, 1-12"
- ⑬ PROP. POLYMERIZED LEVELING BINDER (MACHINE METHOD), IL-4.75, N50, 3/4"
- ⑭ PROP. AGGREGATE WEDGE SHOULDERS, TYPE B
- ⑮ PROP. GRADING & SHAPING SHOULDERS
- ⑯ PROP. COMB. CURB & GUTTER REMOVAL & REPLACEMENT (LOCATIONS TO BE DETERMINED BY THE ENGINEER)
- ⑰ PROP. SIDEWALK REMOVAL & REPLACEMENT (LOCATIONS TO BE DETERMINED BY THE ENGINEER)

REVISIONS		ILLINOIS DEPARTMENT OF TRANSPORTATION ILLINOIS ROUTE 19 (IRVING PARK ROAD) COUNTY LINE TO BAKER STREET EXISTING AND PROPOSED TYPICAL SECTIONS
NAME	DATE	
		SCALE: VERT. _____ HORIZ. _____ DATE _____
DRAWN BY _____		CHECKED BY _____

F.A.U. RTE.	SECTION	COUNTY	TOTAL SHEETS	SHEET NO.
1321	(31&72S)RS-8	DUPAGE	37	10
STA. 105+00		TO STA. 265+89		
FED. ROAD DIST. NO.	ILLINOIS	FED. AID PROJECT		

CONTRACT NO. 62703

IL 19 (IRVING PARK RD)

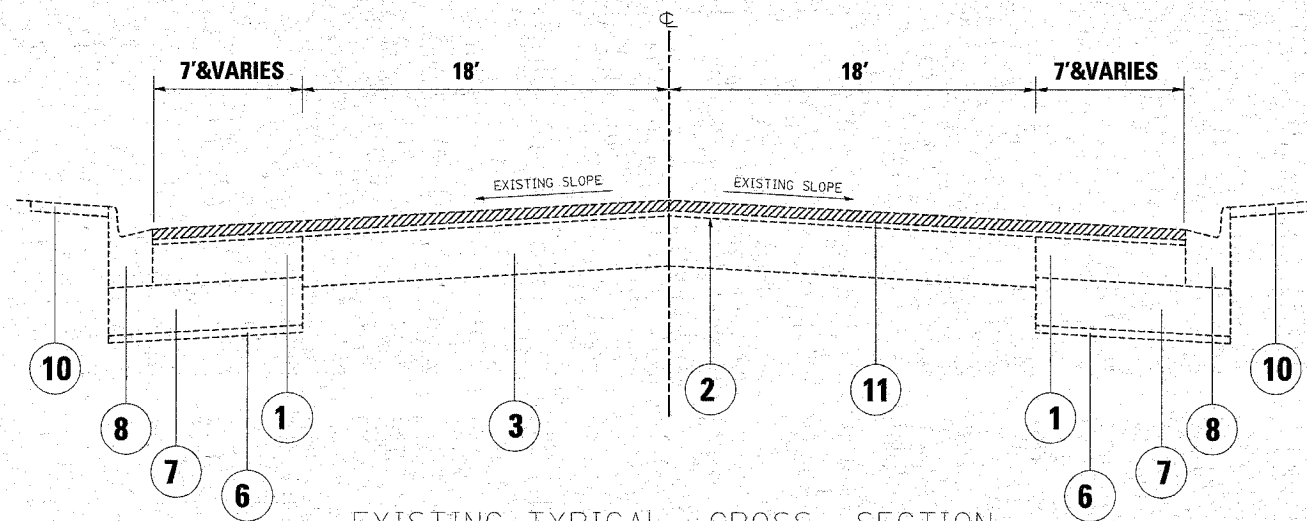

EXISTING TYPICAL CROSS SECTION
STA. 133+08 TO 156+81

IL 19 (IRVING PARK RD)

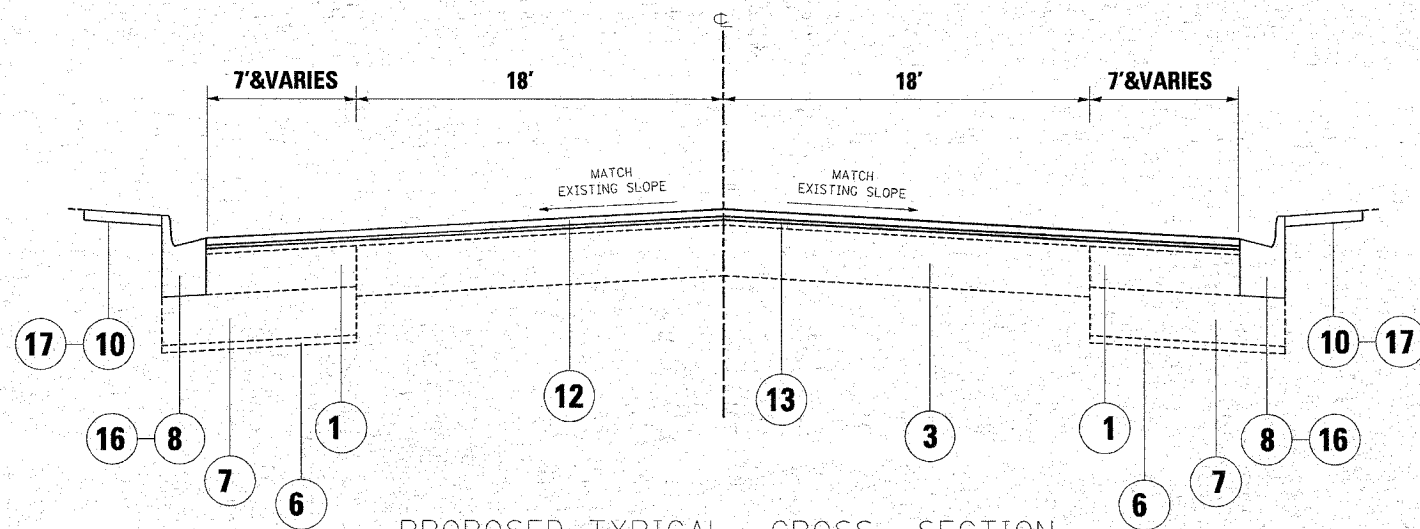

PROPOSED TYPICAL CROSS SECTION
STA. 133+08 TO STA. 156+81

LEGEND

- ① EXISTING HMA CONCRETE WIDENING, 8-10"
- ② EXISTING HMA CONCRETE OVERLAY, VARIES 3-6"
- ③ EXISTING PORTLAND CEMENT CONCRETE 9"-7"-9"
- ④ EXISTING AGGREGATE WEDGE SHOULDER, TYPE B
- ⑤ EXISTING HMA SHOULDER
- ⑥ EXISTING SUB-BASE GRANULAR MATERIAL
- ⑦ EXISTING POROUS GRANULAR EMBANKMENT
- ⑧ EXISTING CONCRETE CURB AND GUTTER, TYPE B-6.12
- ⑨ EXISTING CONCRETE CURB AND GUTTER, TYPE B-6.24
- ⑩ EXISTING PORTLAND CEMENT CONCRETE SIDEWALK, 5"
- ⑪ PROP. HMA SURFACE REMOVAL, 2 1/4"
- ⑫ PROP. HMA SURFACE COURSE, MIX "D" N70, 1-12"
- ⑬ PROP. POLYMERIZED LEVELING BINDER (MACHINE METHOD), IL-4.75, N50, 3/4"
- ⑭ PROP. AGGREGATE WEDGE SHOULDERS, TYPE B
- ⑮ PROP. GRADING & SHAPING SHOULDERS
- ⑯ PROP. COMB. CURB & GUTTER REMOVAL & REPLACEMENT (LOCATIONS TO BE DETERMINED BY THE ENGINEER)
- ⑰ PROP. SIDEWALK REMOVAL & REPLACEMENT (LOCATIONS TO BE DETERMINED BY THE ENGINEER)

REVISIONS	
NAME	DATE

ILLINOIS DEPARTMENT OF TRANSPORTATION
ILLINOIS ROUTE 19 (IRVING PARK ROAD)
WO MITCHELL BLVD. TO BAKER DR.
EXISTING AND PROPOSED
TYPICAL SECTIONS

SCALE: VERT. DRAWN BY
 HORIZ. CHECKED BY
DATE

F.A.U. RTE.	SECTION	COUNTY	TOTAL SHEETS	SHEET NO.
1321	(31&72S)RS-8	DUPAGE	37	11
STA. 105+00		TO STA. 265+89		
FED. ROAD DIST. NO.	ILLINOIS	FED. AID PROJECT		

CONTRACT NO. 62703

IL 19 (IRVING PARK RD)

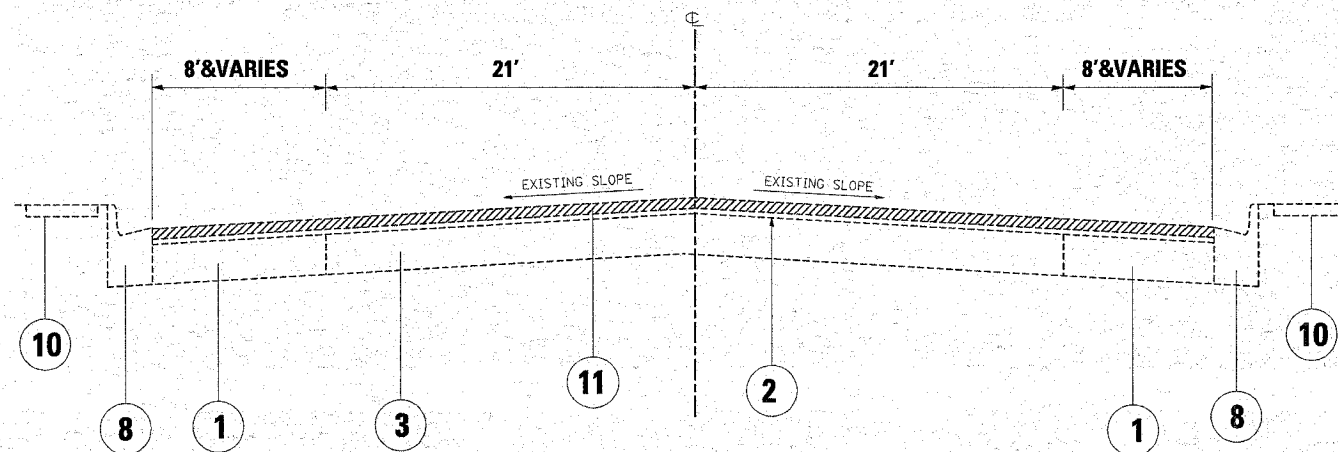

EXISTING TYPICAL CROSS SECTION
STA. 156+81 TO 185+36

RT SIDE ONLY:
B-6.24 C&G
STA. 156+81 TO STA. 166+21

LEGEND

- ① EXISTING HMA CONCRETE WIDENING, 8-10"
- ② EXISTING HMA CONCRETE OVERLAY, VARIES 3-6"
- ③ EXISTING PORTLAND CEMENT CONCRETE 9"-7"-9"
- ④ EXISTING AGGREGATE WEDGE SHOULDER, TYPE B
- ⑤ EXISTING HMA SHOULDER
- ⑥ EXISTING SUB-BASE GRANULAR MATERIAL
- ⑦ EXISTING POROUS GRANULAR EMBANKMENT
- ⑧ EXISTING CONCRETE CURB AND GUTTER, TYPE B-6.12
- ⑨ EXISTING CONCRETE CURB AND GUTTER, TYPE B-6.24
- ⑩ EXISTING PORTLAND CEMENT CONCRETE SIDEWALK, 5"
- ⑪ PROP. HMA SURFACE REMOVAL, 2 1/4"
- ⑫ PROP. HMA SURFACE COURSE, MIX "D" N70, 1-1/2"
- ⑬ PROP. POLYMERIZED LEVELING BINDER (MACHINE METHOD), IL-4.75, N50, 3/4"
- ⑭ PROP. AGGREGATE WEDGE SHOULDERS, TYPE B
- ⑮ PROP. GRADING & SHAPING SHOULDERS
- ⑯ PROP. COMB. CURB & GUTTER REMOVAL & REPLACEMENT (LOCATIONS TO BE DETERMINED BY THE ENGINEER)
- ⑰ PROP. SIDEWALK REMOVAL & REPLACEMENT (LOCATIONS TO BE DETERMINED BY THE ENGINEER)

IL 19 (IRVING PARK RD)

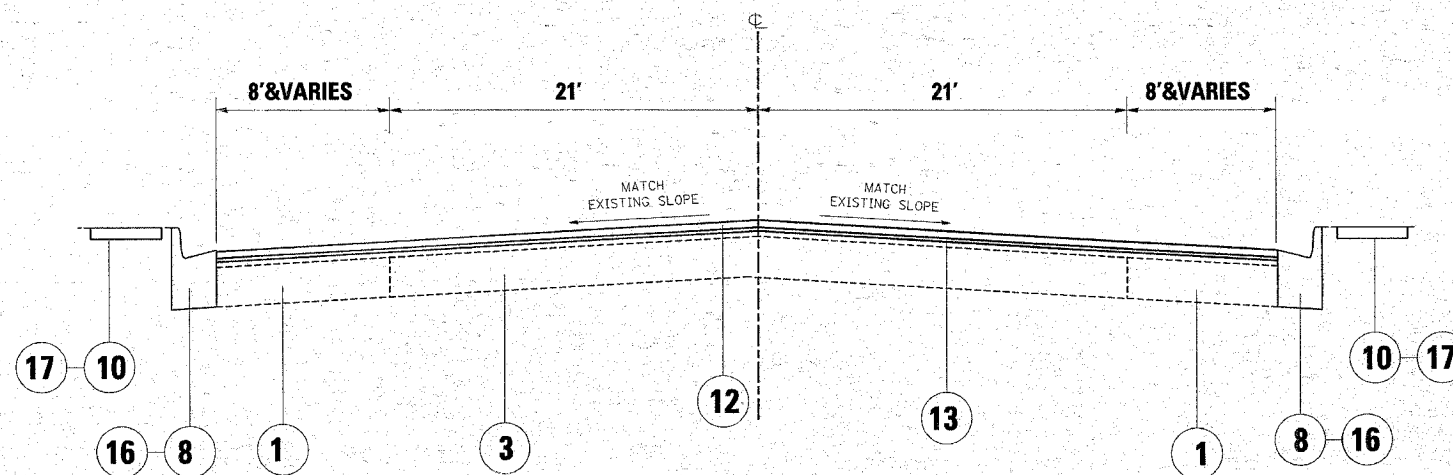

PROPOSED TYPICAL CROSS SECTION
STA. 156+81 TO STA. 185+36

RT SIDE ONLY:
B-6.24 C&G
STA. 156+81 TO STA. 166+21

REVISIONS	
NAME	DATE

ILLINOIS DEPARTMENT OF TRANSPORTATION
ILLINOIS ROUTE 19 (IRVING PARK ROAD)
WO MITCHELL BLVD. TO BAKER DR.
EXISTING AND PROPOSED
TYPICAL SECTIONS

SCALE: VERT.
HORIZ.
DATE

DRAWN BY
CHECKED BY

F.A.U. RTE.	SECTION	COUNTY	TOTAL SHEETS	SHEET NO.
1321	(31&72S)RS-8	DUPAGE	37	12
STA. 105+00		TO STA. 265+89		
FED. ROAD DIST. NO.	ILLINOIS FED. AID PROJECT			

CONTRACT NO. 62703

IL 19 (IRVING PARK RD)

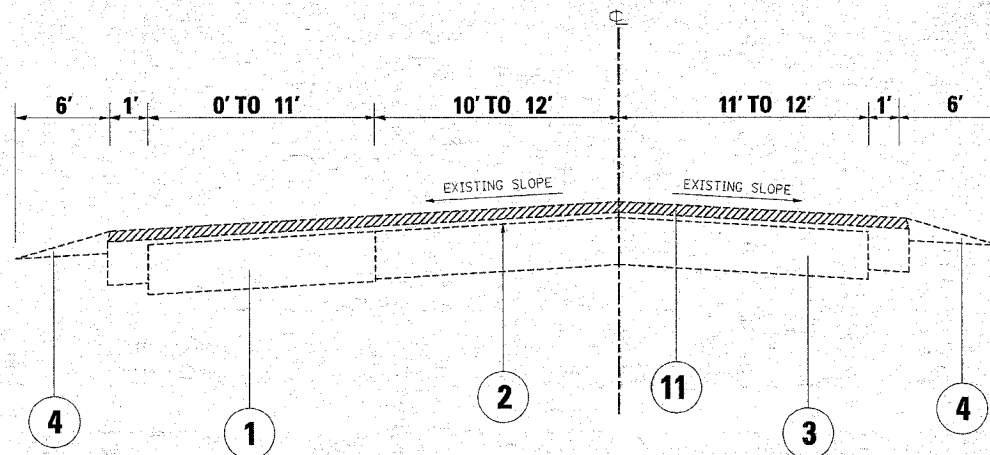

NOTE (LT SIDE ONLY):
NO SHOULDER B-6.12 C&G ONLY
STA. 185+36 TO STA. 189+08

NOTE (RT SIDE ONLY)
B-6.12 C&G WITH 10' BITUMINOUS SHOULDER
STA. 185+36 TO STA. 194+59

EXISTING TYPICAL CROSS SECTION
STA. 185+36 TO STA. 212+77

IL 19 (IRVING PARK RD)

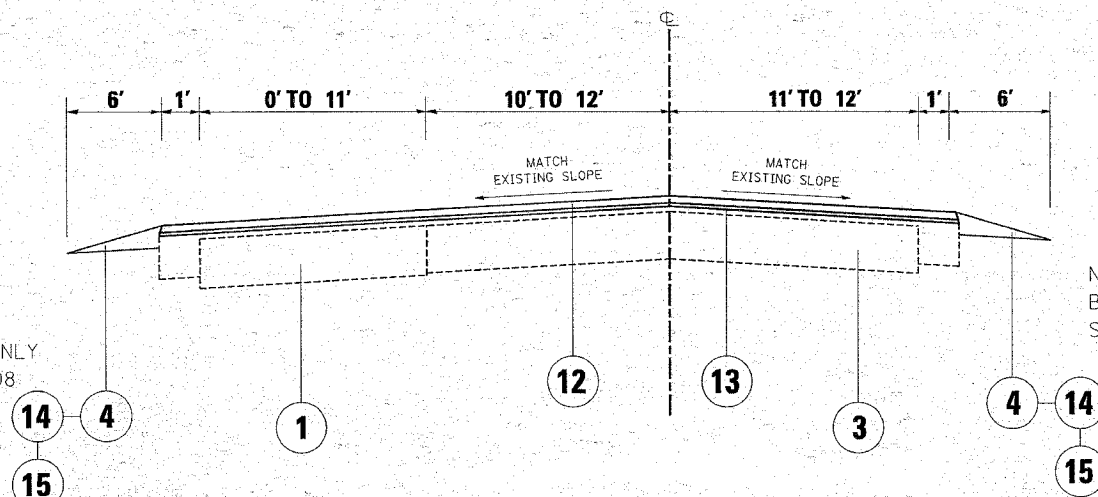

NOTE (LT SIDE ONLY):
NO SHOULDER B-6.12 C&G ONLY
STA. 185+36 TO STA. 189+08

NOTE (RT SIDE ONLY)
B-6.12 C&G WITH 10' BITUMINOUS SHOULDER
STA. 185+36 TO STA. 194+59

PROPOSED TYPICAL CROSS SECTION
STA. 185+36 TO STA. 212+77

LEGEND

- ① EXISTING HMA CONCRETE WIDENING, 8-10"
- ② EXISTING HMA CONCRETE OVERLAY, VARIES 3-6"
- ③ EXISTING PORTLAND CEMENT CONCRETE 9"-7"-9"
- ④ EXISTING AGGREGATE WEDGE SHOULDER, TYPE B
- ⑤ EXISTING HMA SHOULDER
- ⑥ EXISTING SUB-BASE GRANULAR MATERIAL
- ⑦ EXISTING POROUS GRANULAR EMBANKMENT
- ⑧ EXISTING CONCRETE CURB AND GUTTER, TYPE B-6.12
- ⑨ EXISTING CONCRETE CURB AND GUTTER, TYPE B-6.24
- ⑩ EXISTING PORTLAND CEMENT CONCRETE SIDEWALK, 5"
- ⑪ PROP. HMA SURFACE REMOVAL, 2 1/4"
- ⑫ PROP. HMA SURFACE COURSE, MIX "D" N70, 1-1/2"
- ⑬ PROP. POLYMERIZED LEVELING BINDER (MACHINE METHOD), IL-4.75, N50, 3/4"
- ⑭ PROP. AGGREGATE WEDGE SHOULDERS, TYPE B
- ⑮ PROP. GRADING & SHAPING SHOULDERS
- ⑯ PROP. COMB. CURB & GUTTER REMOVAL & REPLACEMENT (LOCATIONS TO BE DETERMINED BY THE ENGINEER)
- ⑰ PROP. SIDEWALK REMOVAL & REPLACEMENT (LOCATIONS TO BE DETERMINED BY THE ENGINEER)

REVISIONS	
NAME	DATE

ILLINOIS DEPARTMENT OF TRANSPORTATION
ILLINOIS ROUTE 19 (IRVING PARK ROAD)
WO MITCHELL BLVD. TO BAKER DR.
EXISTING AND PROPOSED
TYPICAL SECTIONS

SCALE: VERT. _____
HORIZ. _____
DATE _____ DRAWN BY _____
CHECKED BY _____

F.A.I. RTE.	SECTION	COUNTY	TOTAL SHEETS	SHEET NO.
1321	(31&72S)RS-8	DUPAGE	37	13
STA. 105+00		TO STA. 265+89		
FED. ROAD DIST. NO.	ILLINOIS	FED. AID PROJECT		

CONTRACT NO. 62703

IL 19 (IRVING PARK RD)

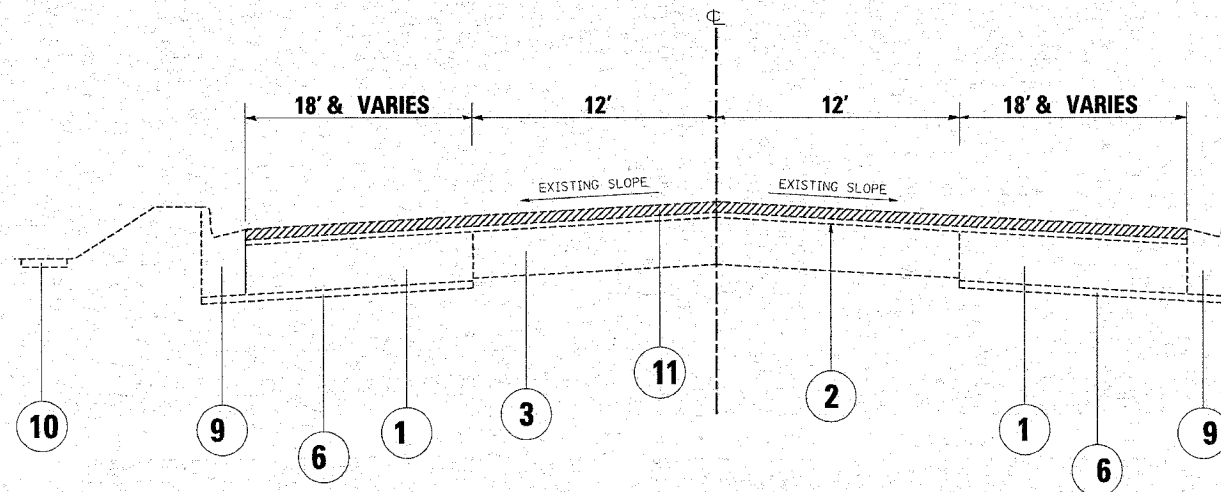

EXISTING TYPICAL CROSS SECTION
STA. 212+77 TO STA. 229+12

IL 19 (IRVING PARK RD)

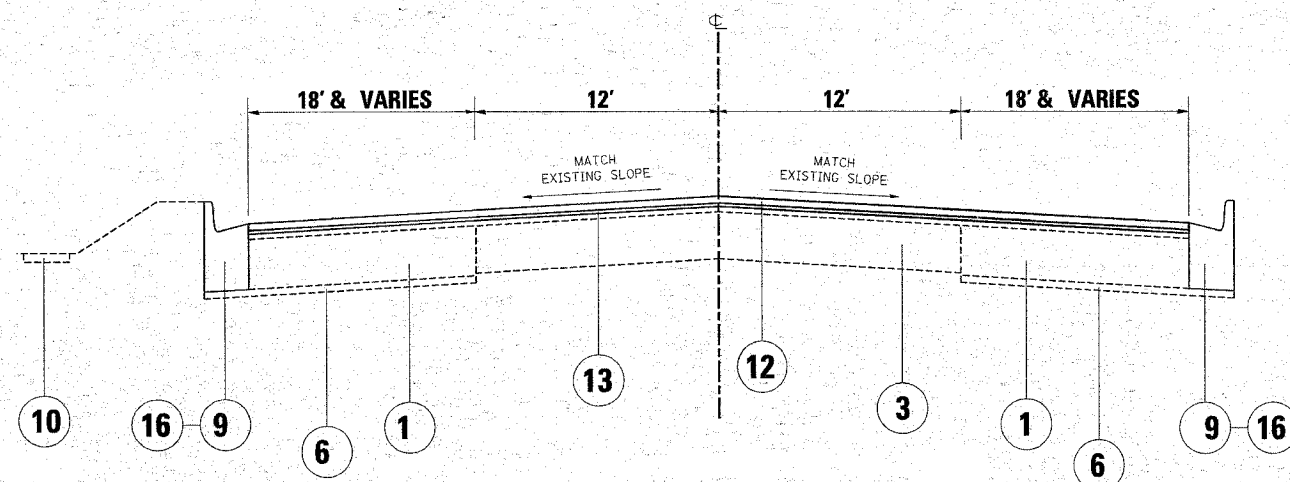

PROPOSED TYPICAL CROSS SECTION
STA. 212+77 TO STA. 229+12

LEGEND

- ① EXISTING HMA CONCRETE WIDENING, 8-10"
- ② EXISTING HMA CONCRETE OVERLAY, VARIES 3-6"
- ③ EXISTING PORTLAND CEMENT CONCRETE 9"-7"-9"
- ④ EXISTING AGGREGATE WEDGE SHOULDER, TYPE B
- ⑤ EXISTING HMA SHOULDER
- ⑥ EXISTING SUB-BASE GRANULAR MATERIAL
- ⑦ EXISTING POROUS GRANULAR EMBANKMENT
- ⑧ EXISTING CONCRETE CURB AND GUTTER, TYPE B-6.12
- ⑨ EXISTING CONCRETE CURB AND GUTTER, TYPE B-6.24
- ⑩ EXISTING PORTLAND CEMENT CONCRETE SIDEWALK, 5"
- ⑪ PROP. HMA SURFACE REMOVAL, 2 1/4"
- ⑫ PROP. HMA SURFACE COURSE, MIX "D" N70, 1-1/2"
- ⑬ PROP. POLYMERIZED LEVELING BINDER (MACHINE METHOD), IL-4.75, N50, 3/4"
- ⑭ PROP. AGGREGATE WEDGE SHOULDERS, TYPE B
- ⑮ PROP. GRADING & SHAPING SHOULDERS
- ⑯ PROP. COMB. CURB & GUTTER REMOVAL & REPLACEMENT (LOCATIONS TO BE DETERMINED BY THE ENGINEER)
- ⑰ PROP. SIDEWALK REMOVAL & REPLACEMENT (LOCATIONS TO BE DETERMINED BY THE ENGINEER)

REVISIONS	
NAME	DATE

ILLINOIS DEPARTMENT OF TRANSPORTATION
ILLINOIS ROUTE 19 (IRVING PARK ROAD)
WO MITCHELL BLVD. TO BAKER DR.
EXISTING AND PROPOSED
TYPICAL SECTIONS

SCALE: VERT. DRAWN BY
 HORIZ. CHECKED BY
DATE

IL 19 (IRVING PARK RD)

NOTE (LT SIDE ONLY):
 B-6.12 C&G WITH
 10' BITUMINOUS SHOULDER
 STA. 262+50 TO STA. 265+89

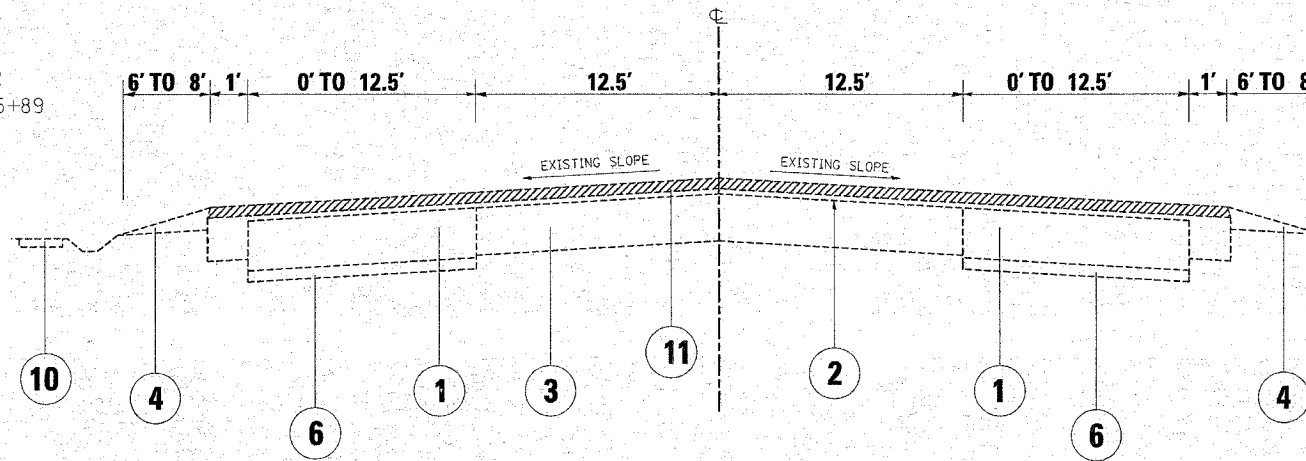

EXISTING TYPICAL CROSS SECTION
 STA. 229+12 TO STA. 265+89

IL 19 (IRVING PARK RD)

NOTE (LT SIDE ONLY):
 B-6.12 C&G WITH
 10' BITUMINOUS SHOULDER
 STA. 262+50 TO STA. 265+89

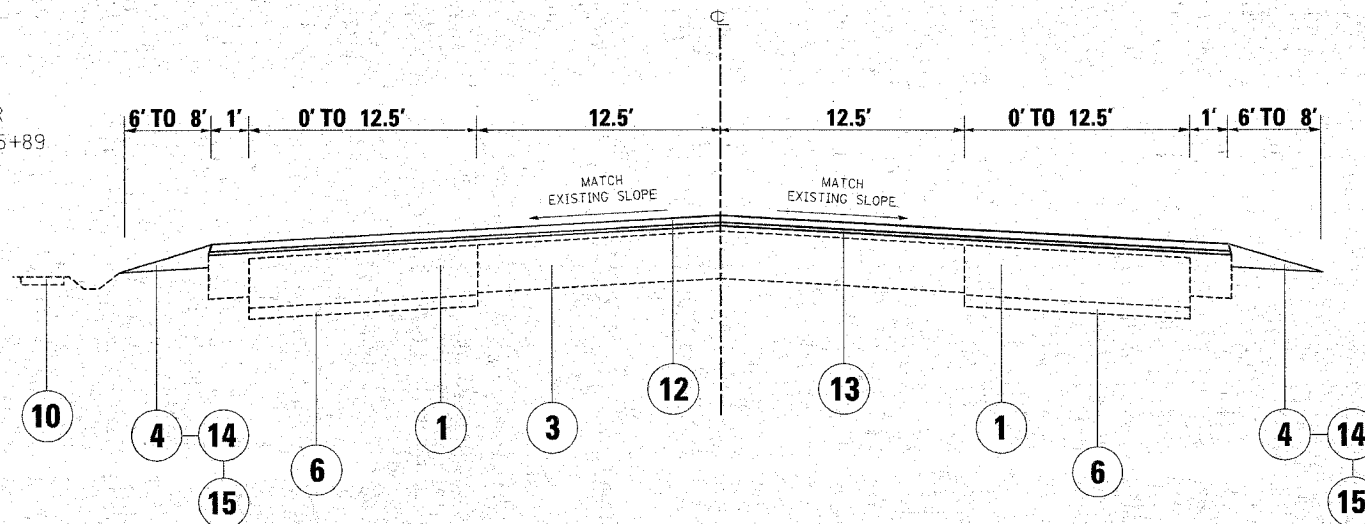

PROPOSED TYPICAL CROSS SECTION
 STA. 229+12 TO STA. 265+89

LEGEND

- ① EXISTING HMA CONCRETE WIDENING, 8-10"
- ② EXISTING HMA CONCRETE OVERLAY, VARIES 3-6"
- ③ EXISTING PORTLAND CEMENT CONCRETE 9"-7"-9"
- ④ EXISTING AGGREGATE WEDGE SHOULDER, TYPE B
- ⑤ EXISTING HMA SHOULDER
- ⑥ EXISTING SUB-BASE GRANULAR MATERIAL
- ⑦ EXISTING POROUS GRANULAR EMBANKMENT
- ⑧ EXISTING CONCRETE CURB AND GUTTER, TYPE B-6.12
- ⑨ EXISTING CONCRETE CURB AND GUTTER, TYPE B-6.24
- ⑩ EXISTING PORTLAND CEMENT CONCRETE SIDEWALK, 5"
- ⑪ PROP. HMA SURFACE REMOVAL, 2 1/4"
- ⑫ PROP. HMA SURFACE COURSE, MIX "D" N70, 1-1/2"
- ⑬ PROP. POLYMERIZED LEVELING BINDER (MACHINE METHOD), IL-4.75, N50, 3/4"
- ⑭ PROP. AGGREGATE WEDGE SHOULDERS, TYPE B
- ⑮ PROP. GRADING & SHAPING SHOULDERS
- ⑯ PROP. COMB. CURB & GUTTER REMOVAL & REPLACEMENT (LOCATIONS TO BE DETERMINED BY THE ENGINEER)
- ⑰ PROP. SIDEWALK REMOVAL & REPLACEMENT (LOCATIONS TO BE DETERMINED BY THE ENGINEER)

REVISIONS	
NAME	DATE

ILLINOIS DEPARTMENT OF TRANSPORTATION
 ILLINOIS ROUTE 19 (IRVING PARK ROAD)
 W/O MITCHELL BLVD. TO BAKER DR.
 EXISTING AND PROPOSED
 TYPICAL SECTIONS

SCALE: VERT. _____
 HORIZ. _____
 DATE _____ DRAWN BY _____
 CHECKED BY _____

F.A.U. RTE.	SECTION	COUNTY	TOTAL SHEETS	SHEET NO.
1321	(31&72)RS-8	DUPAGE	37	15
STA. 88+88		TO STA. 105+00		
FED. ROAD DIST. NO. 1		ILLINOIS FED. AID PROJECT		

CONTRACT NO. 62703

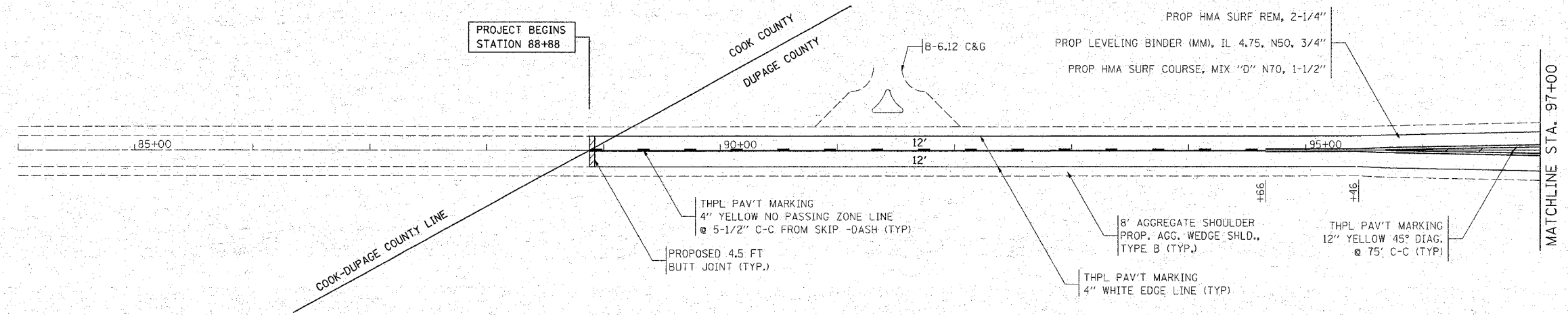

- SIDESTREETS:
 - RESURFACING LIMITS ARE TO RADIUS RETURNS WITH 4.5' BUTT JOINTS
 - PROPOSED HMA SURFACE REMOVAL, 2 1/4"
 - PROPOSED POLYMERIZED LEVELING BINDER (MACHINE METHOD), IL-4.75, N50, 3/4"
 - PROPOSED POLYMERIZED HMA SURFACE COURSE, MIX "D", N70, 1 1/2"

NOTE:
FOR RAISED REFLECTIVE PAVEMENT MARKERS, REFER TO TYPICAL APPLICATIONS RAISED REFLECTIVE PAVEMENT MARKERS (SNOW-PLOW RESISTANT) AND DISTRICT TYPICAL PAVEMENT MARKINGS

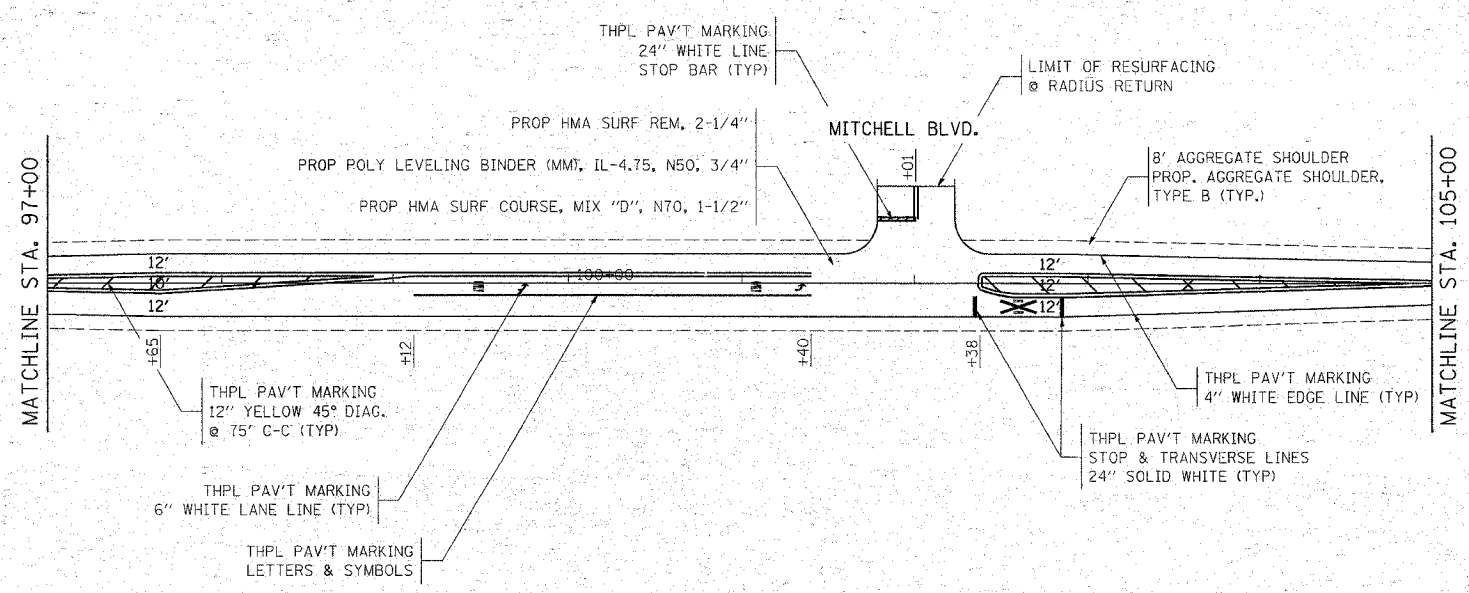

REVISIONS	
NAME	DATE

ILLINOIS DEPARTMENT OF TRANSPORTATION
**ILLINOIS ROUTE 19 (IRVING PARK ROAD)
 W/O MITCHELL BLVD. TO BAKER DR.**
**ROADWAY AND
 PAVEMENT MARKING PLAN**
 SCALE: VERT. 1" = 50'
 HORIZ. DATE
 DRAWN BY
 CHECKED BY

F.A.U. RTE.	SECTION	COUNTY	TOTAL SHEETS	SHEET NO.
1321	(31&72S)RS-8	DUPAGE	37	16
STA. 105+00		TO STA. 128+00		
FED. ROAD DIST. NO.	ILLINOIS	FED. AID PROJECT		

CONTRACT NO. 62703

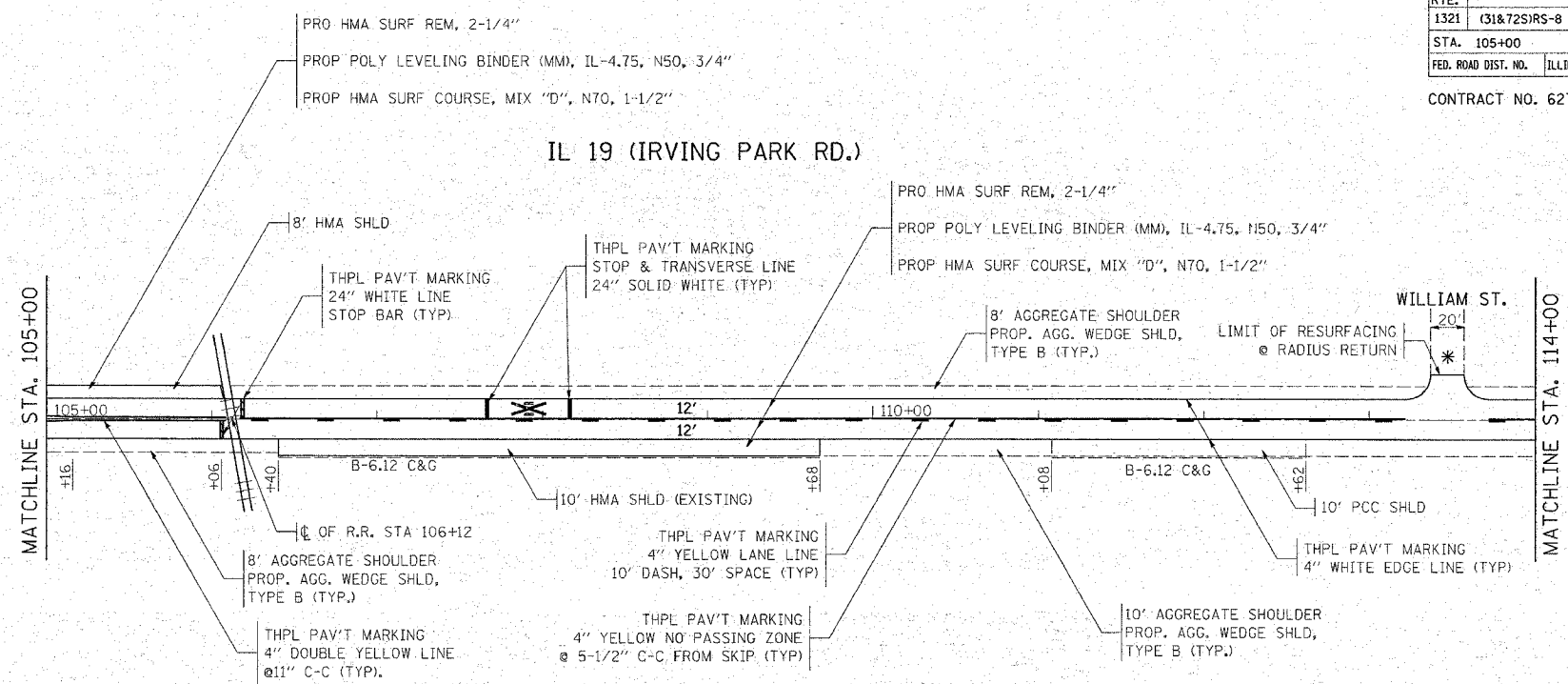
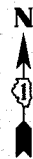

- SIDESTREETS:
 -RESURFACING LIMITS ARE TO RADIUS RETURNS WITH 4.5' BUTT JOINTS
- PROPOSED HMA SURFACE REMOVAL, 2 1/4"
- PROPOSED POLYMERIZED LEVELING BINDER (MACHINE METHOD), IL-4.75, N50, 3/4"
- PROPOSED POLYMERIZED HMA SURFACE COURSE, MIX "D", N70, 1 1/2"

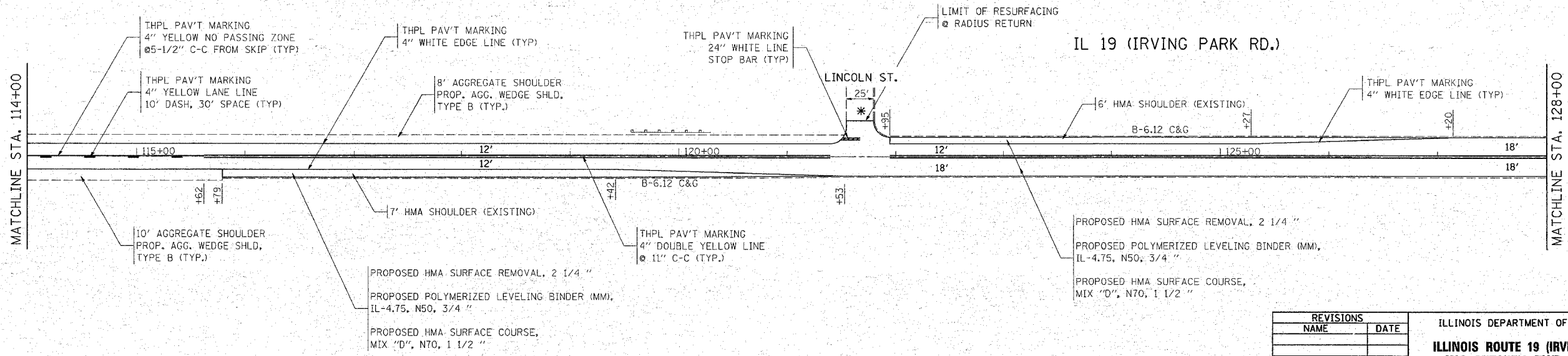

NOTE:
 FOR RAISED REFLECTIVE PAVEMENT MARKERS, REFER TO TYPICAL APPLICATIONS RAISED REFLECTIVE PAVEMENT MARKERS (SNOW-LOW RESISTANT) AND DISTRICT TYPICAL PAVEMENT MARKINGS

REVISIONS	
NAME	DATE

ILLINOIS DEPARTMENT OF TRANSPORTATION
**ILLINOIS ROUTE 19 (IRVING PARK ROAD)
 W/O MITCHELL BLVD. TO BAKER DR.**
**ROADWAY AND
 PAVEMENT MARKING PLAN**
 SCALE: VERT. 1" = 50'
 HORIZ. DATE
 DRAWN BY
 CHECKED BY

F.A.U. RTE.	SECTION	COUNTY	TOTAL SHEETS	SHEET NO.
1321	31&72S/RS-8	DUPAGE	37	17
STA. 105+00		TO STA. 156+00		
FED. ROAD DIST. NO.		ILLINOIS	FED. AID PROJECT	

CONTRACT NO. 62703

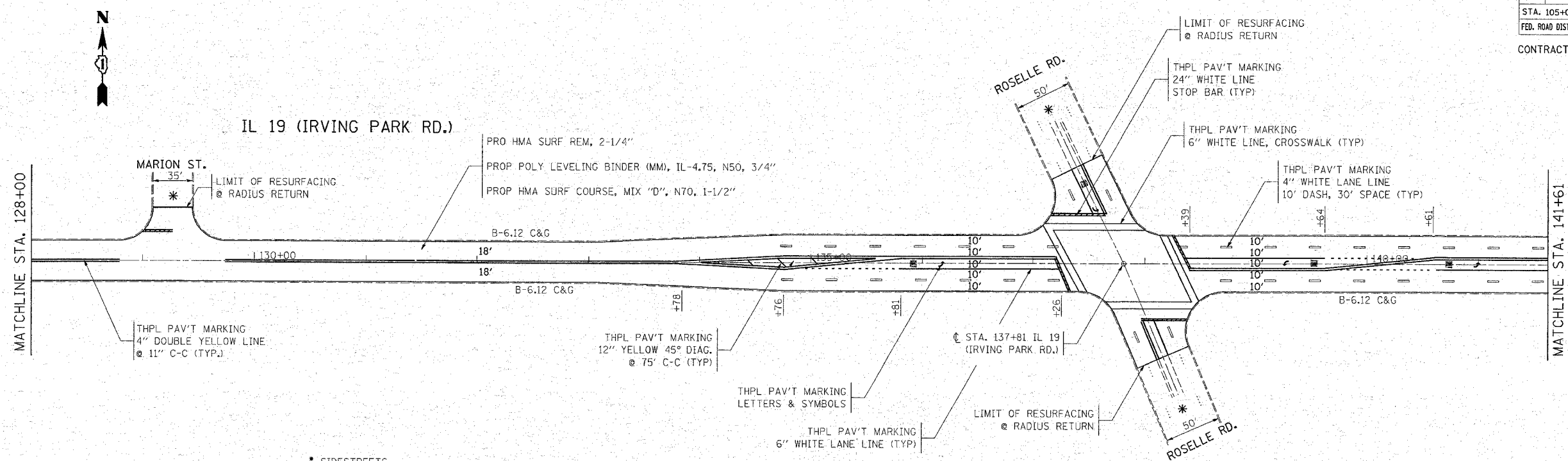

- SIDESTREETS:
 -RESURFACING LIMITS ARE TO RADIUS RETURNS WITH 4.5' BUTT JOINTS
 -PROPOSED HMA SURFACE REMOVAL, 2 1/4"
 -PROPOSED POLYMERIZED LEVELING BINDER (MACHINE METHOD), IL-4.75, N50, 3/4"
 -PROPOSED POLYMERIZED HMA SURFACE COURSE, MIX "D", N70, 1 1/2"

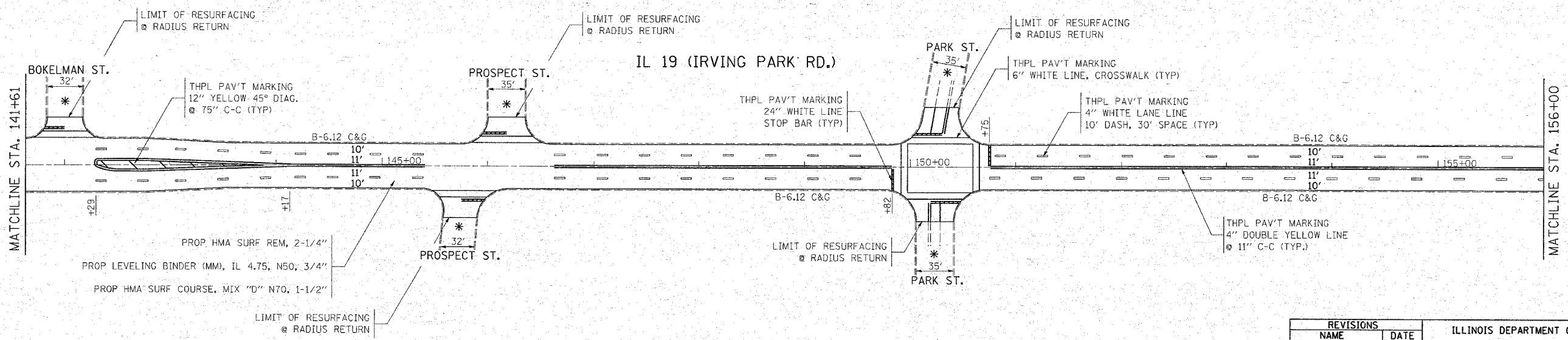

NOTE:
 FOR RAISED REFLECTIVE PAVEMENT MARKERS, REFER TO TYPICAL APPLICATIONS RAISED REFLECTIVE PAVEMENT MARKERS (SNOW-PLOW RESISTANT) AND DISTRICT TYPICAL PAVEMENT MARKINGS

REVISIONS	
NAME	DATE

ILLINOIS DEPARTMENT OF TRANSPORTATION
**ILLINOIS ROUTE 19 (IRVING PARK ROAD)
 WO MITCHELL BLVD. TO BAKER DR.**
**ROADWAY AND
 PAVEMENT MARKING PLAN**
 SCALE: VERT. 1" = 50'
 HORIZ. 1" = 50'
 DATE _____ DRAWN BY _____
 CHECKED BY _____

F.A.U. RTE.	SECTION	COUNTY	TOTAL SHEETS	SHEET NO.
1321	(31&725)RS-8	DUPAGE	37	18
STA. 156+00		TO STA. 184+00		
FED. ROAD DIST. NO.	ILLINOIS	FED. AID PROJECT		

CONTRACT NO. 62703

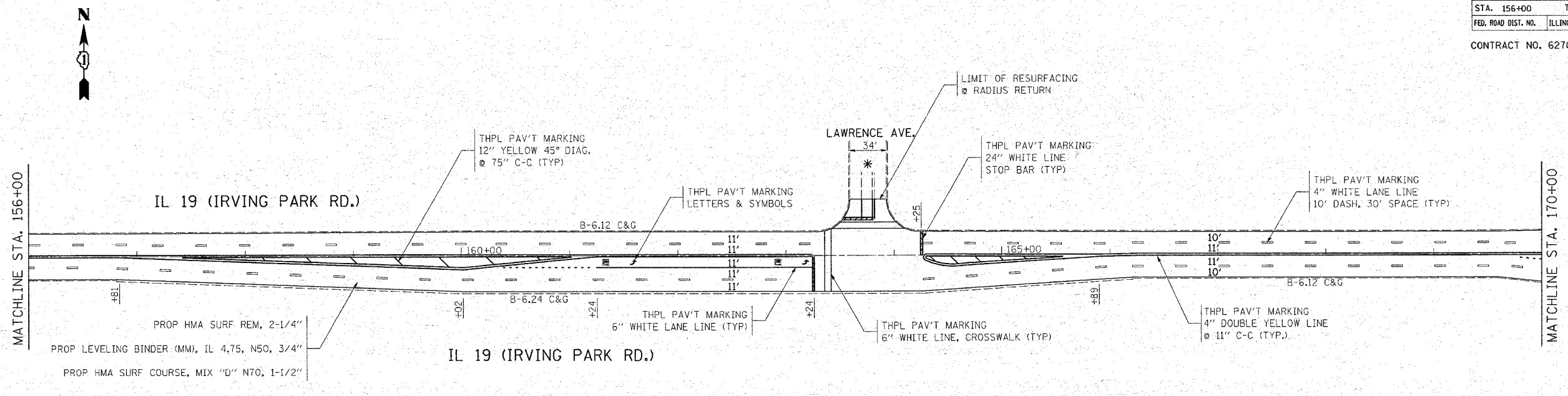

- * SIDESTREETS:
 -RESURFACING LIMITS ARE TO RADIUS RETURNS WITH 4.5' BUTT JOINTS
 -PROPOSED HMA SURFACE REMOVAL, 2 1/4"
 -PROPOSED POLYMERIZED LEVELING BINDER (MACHINE METHOD), IL-4.75, N50, 3/4"
 -PROPOSED POLYMERIZED HMA SURFACE COURSE, MIX "D", N70, 1 1/2"

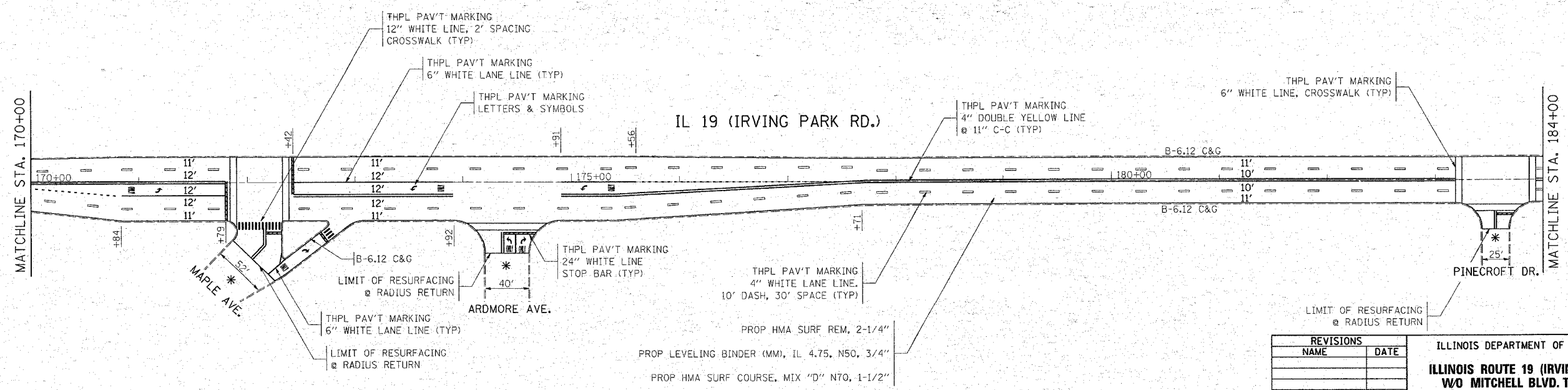

NOTE:
 FOR RAISED REFLECTIVE PAVEMENT MARKERS, REFER TO TYPICAL APPLICATIONS RAISED REFLECTIVE PAVEMENT MARKERS (SNOW-PROOF RESISTANT) AND DISTRICT TYPICAL PAVEMENT MARKINGS

REVISIONS	
NAME	DATE

ILLINOIS DEPARTMENT OF TRANSPORTATION
**ILLINOIS ROUTE 19 (IRVING PARK ROAD)
 W/O MITCHELL BLVD. TO BAKER DR.**
**ROADWAY AND
 PAVEMENT MARKING PLAN**
 SCALE: VERT. 1" = 50'
 HORIZ. 1" = 50'
 DATE _____ DRAWN BY _____
 CHECKED BY _____

F.A.U. RTE.	SECTION	COUNTY	TOTAL SHEETS	SHEET NO.
1321	(31&72S)RS-8	DUPAGE	37	19
STA. 184+00		TO STA. 212+00		
FED. ROAD DIST. NO.		ILLINOIS FED. AID PROJECT		

CONTRACT NO. 62703

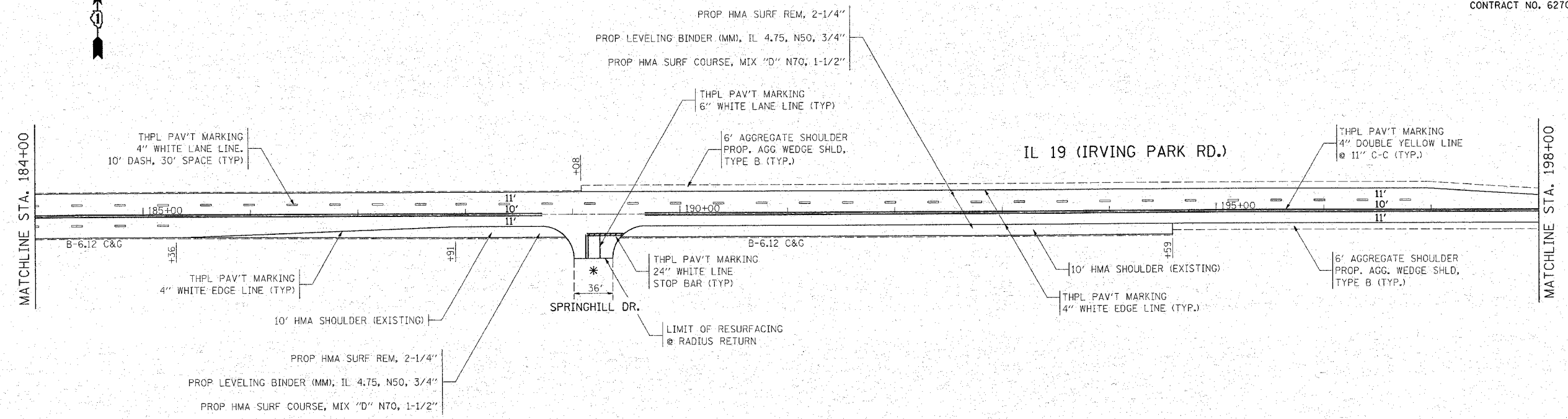

- * SIDESTREETS:
 -RESURFACING LIMITS ARE TO RADIUS RETURNS WITH 4.5' BUTT JOINTS
 -PROPOSED HMA SURFACE REMOVAL, 2 1/4"
 -PROPOSED POLYMERIZED LEVELING BINDER (MACHINE METHOD), IL-4.75, N50, 3/4"
 -PROPOSED POLYMERIZED HMA SURFACE COURSE, MIX "D", N70, 1 1/2"

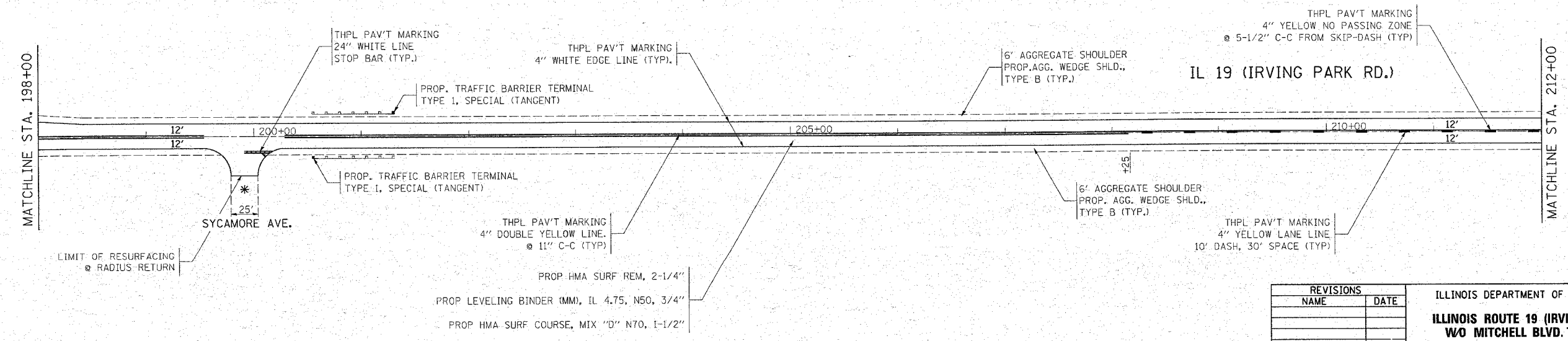

NOTE:
 FOR RAISED REFLECTIVE PAVEMENT MARKERS, REFER TO TYPICAL APPLICATIONS RAISED REFLECTIVE PAVEMENT MARKERS (SNOW-PLOW RESISTANT) AND DISTRICT TYPICAL PAVEMENT MARKINGS

REVISIONS	
NAME	DATE

ILLINOIS DEPARTMENT OF TRANSPORTATION
**ILLINOIS ROUTE 19 (IRVING PARK ROAD)
 WO MITCHELL BLVD. TO BAKER DR.**
**ROADWAY AND
 PAVEMENT MARKING PLAN**
 SCALE: VERT. 1" = 50'
 HORIZ. 1" = 50'
 DATE _____ DRAWN BY _____
 CHECKED BY _____

F.A.U. RTE.	SECTION	COUNTY	TOTAL SHEETS	SHEET NO.
1321	(31&72S)RS-8	DUPAGE	37	20
STA. 212+00		TO STA. 240+00		
FED. ROAD DIST. NO.		ILLINOIS FED. AID PROJECT		

CONTRACT NO. 62703

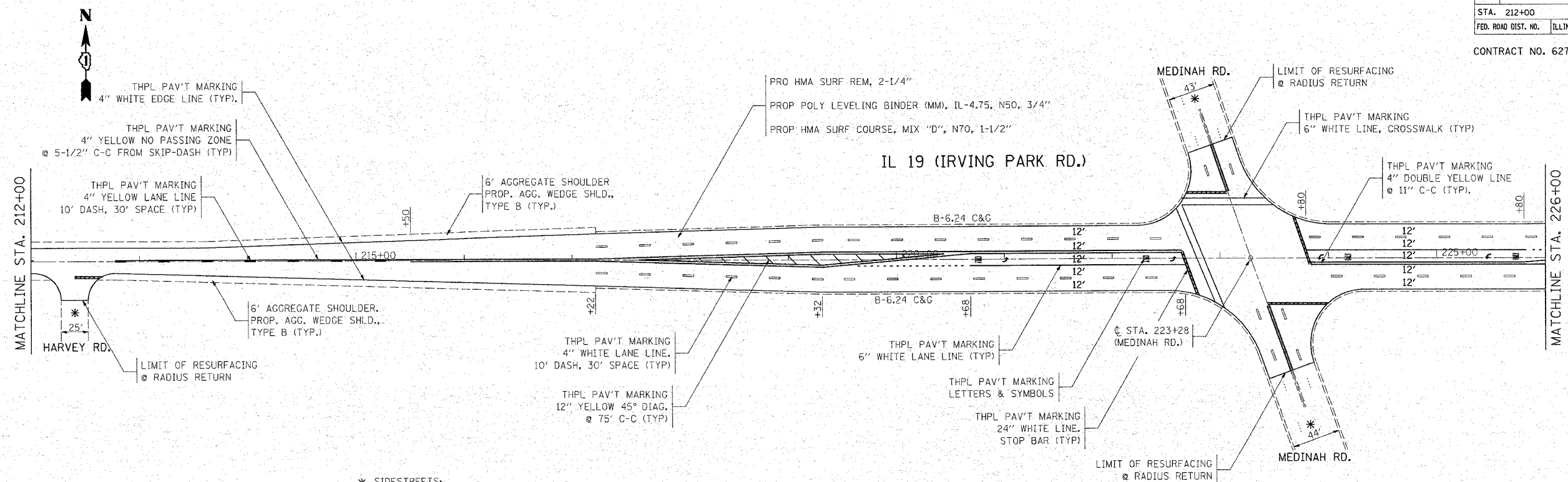

- * SIDESTREETS:
 -RESURFACING LIMITS ARE TO RADIUS RETURNS WITH 4.5' BUTT JOINTS
 -PROPOSED HMA SURFACE REMOVAL, 2 1/4"
 -PROPOSED POLYMERIZED LEVELING BINDER (MACHINE METHOD), IL-4.75, N50, 3/4"
 -PROPOSED POLYMERIZED HMA SURFACE COURSE, MIX "D", N70, 1 1/2"

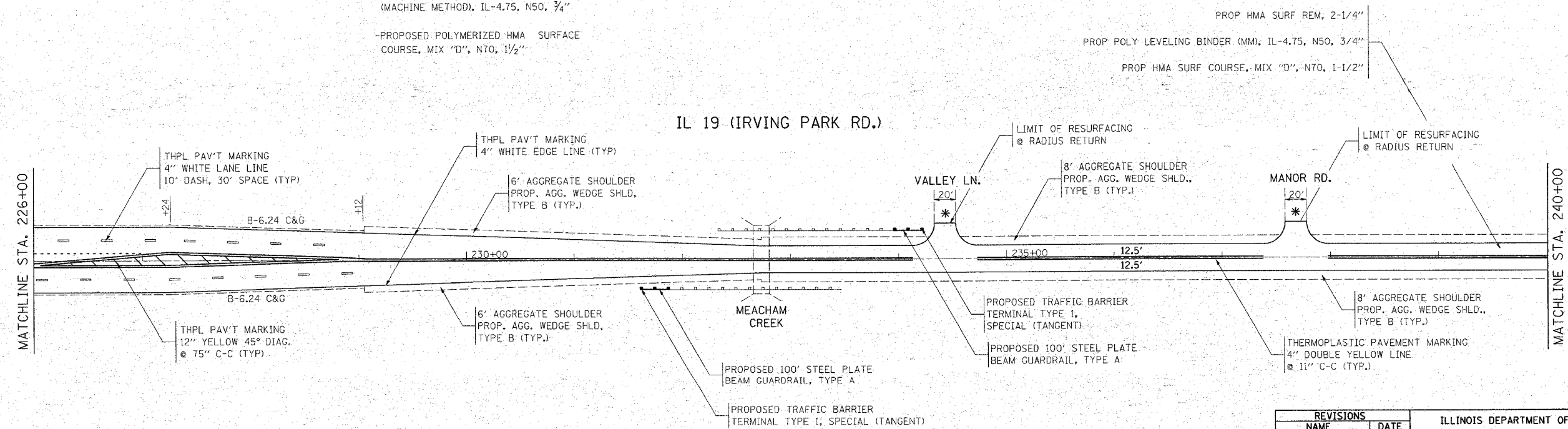

NOTE:
 FOR RAISED REFLECTIVE PAVEMENT MARKERS, REFER TO TYPICAL APPLICATIONS RAISED REFLECTIVE PAVEMENT MARKERS (SNOW-PLOW RESISTANT) AND DISTRICT TYPICAL PAVEMENT MARKINGS

REVISIONS	
NAME	DATE

ILLINOIS DEPARTMENT OF TRANSPORTATION
**ILLINOIS ROUTE 19 (IRVING PARK ROAD)
 W/O MITCHELL BLVD. TO BAKER DR.**
**ROADWAY AND
 PAVEMENT MARKING PLAN**
 SCALE: VERT. 1" = 50'
 HORIZ. 1" = 50'
 DATE: _____ DRAWN BY: _____
 CHECKED BY: _____

F.A.U. RTE.	SECTION	COUNTY	TOTAL SHEETS	SHEET NO.
1321	(31&72S)RS-8	DUPAGE	37	21
STA. 240+00		TO STA. 265+89		
FED. ROAD DIST. NO.		ILLINOIS	FED. AID PROJECT	

CONTRACT NO. 62703

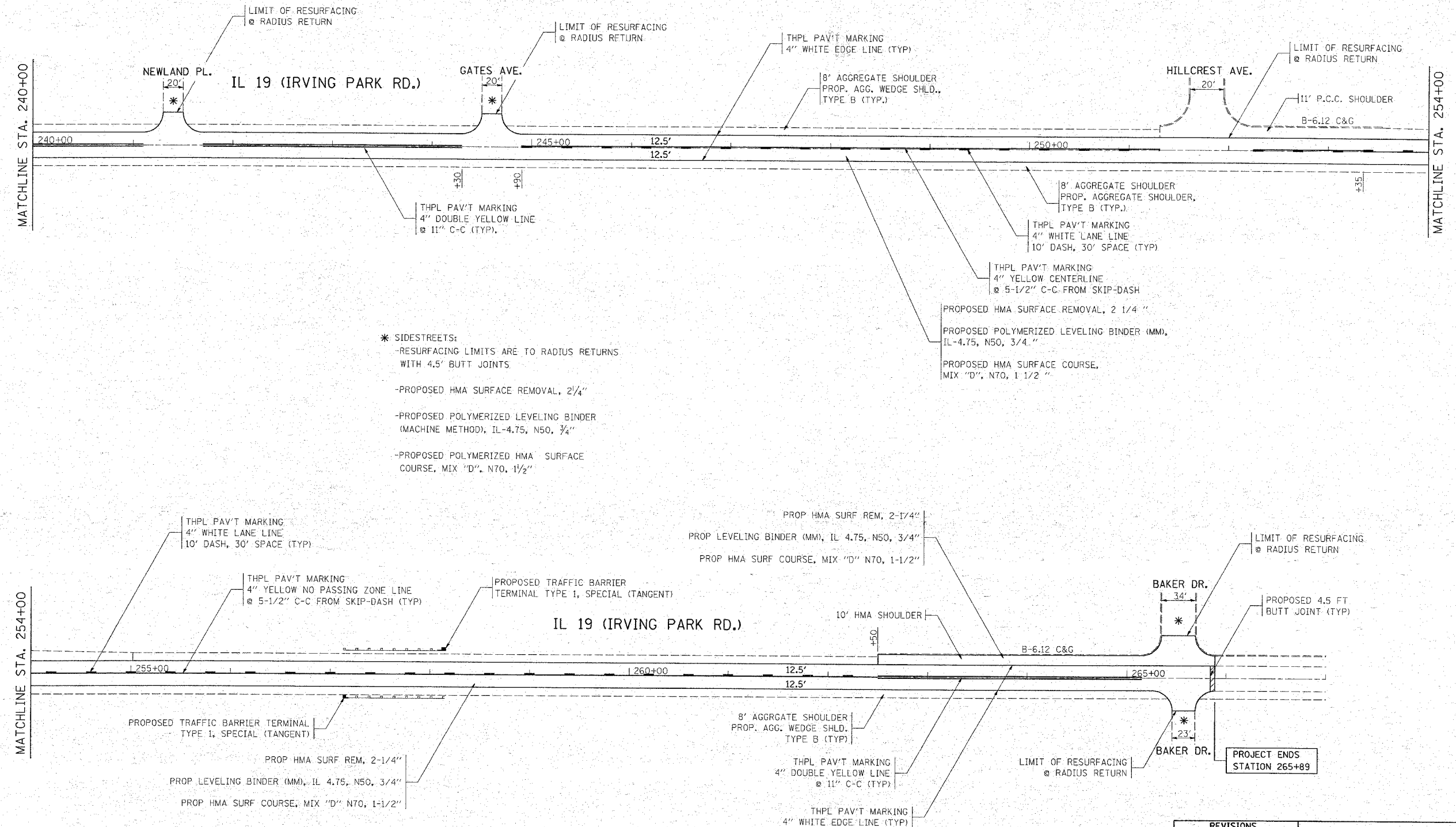

- * SIDESTREETS:
- RESURFACING LIMITS ARE TO RADIUS RETURNS WITH 4.5' BUTT JOINTS
 - PROPOSED HMA SURFACE REMOVAL, 2 1/4"
 - PROPOSED POLYMERIZED LEVELING BINDER (MACHINE METHOD), IL-4.75, N50, 3/4"
 - PROPOSED POLYMERIZED HMA SURFACE COURSE, MIX "D", N70, 1-1/2"

NOTE:
FOR RAISED REFLECTIVE PAVEMENT MARKERS, REFER TO TYPICAL APPLICATIONS RAISED REFLECTIVE PAVEMENT MARKERS (SNOW-PLOW RESISTANT) AND DISTRICT TYPICAL PAVEMENT MARKINGS

REVISIONS	
NAME	DATE

ILLINOIS DEPARTMENT OF TRANSPORTATION
**ILLINOIS ROUTE 19 (IRVING PARK ROAD)
W/O MITCHELL BLVD. TO BAKER DR.**
**ROADWAY AND
PAVEMENT MARKING PLAN**
SCALE: VERT. 1" = 50'
DATE _____ HORIZ. 1" = 50'
DRAWN BY _____
CHECKED BY _____

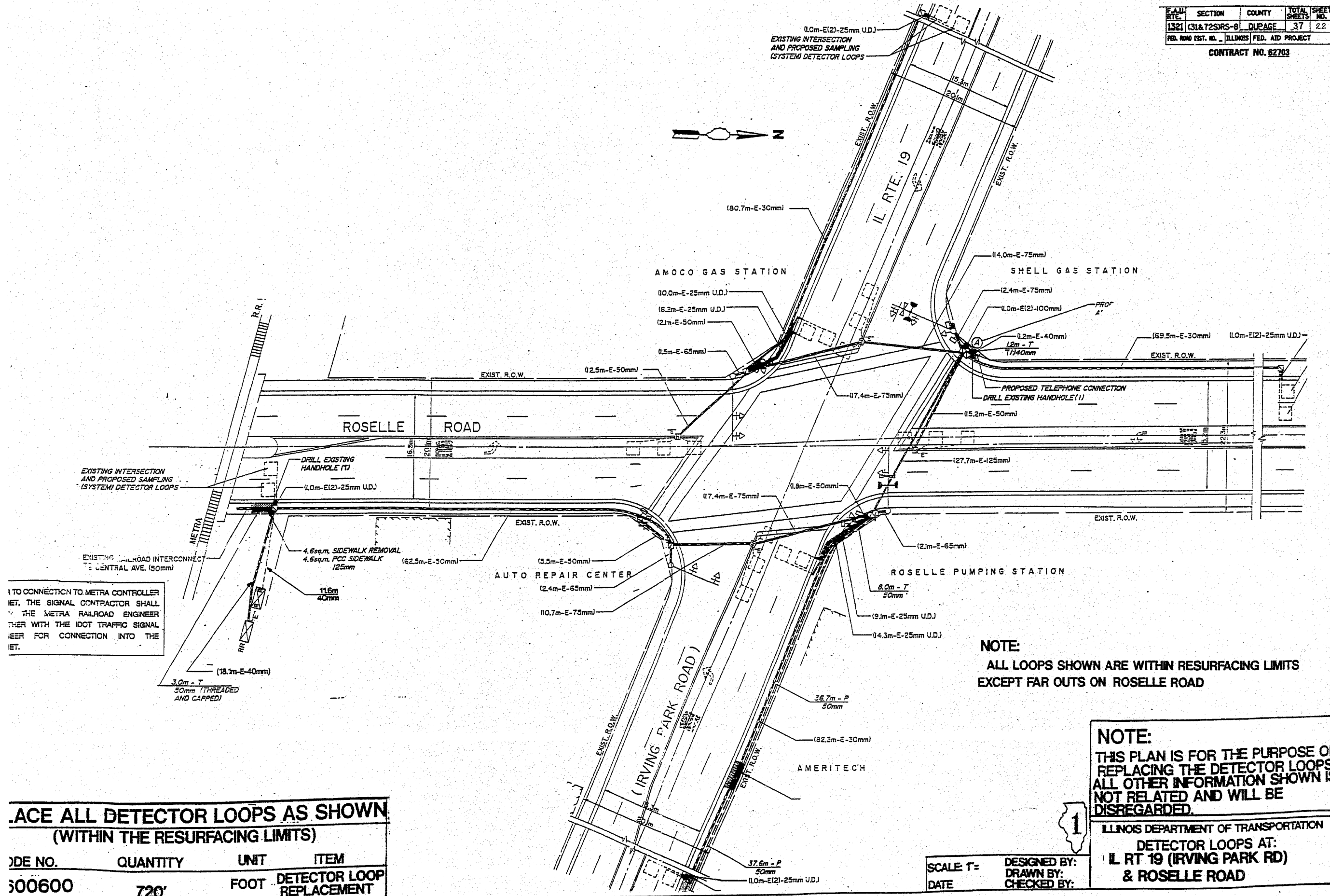

PLACE ALL DETECTOR LOOPS AS SHOWN (WITHIN THE RESURFACING LIMITS)

CODE NO.	QUANTITY	UNIT	ITEM
300600	720'	FOOT	DETECTOR LOOP REPLACEMENT

SCALE 1" =
DATE

DESIGNED BY:
DRAWN BY:
CHECKED BY:

NOTE:
THIS PLAN IS FOR THE PURPOSE OF REPLACING THE DETECTOR LOOPS. ALL OTHER INFORMATION SHOWN IS NOT RELATED AND WILL BE DISREGARDED.

ILLINOIS DEPARTMENT OF TRANSPORTATION
DETECTOR LOOPS AT:
IL RT 19 (IRVING PARK RD)
& ROSELLE ROAD

F.A. RTE.	SECTION	COUNTY	TOTAL SHEETS	SHEET NO.
1321	C31&72SRS-8	DUPAGE	37	23
FED. ROAD DIST. NO. - ILLINOIS FED. AID PROJECT				
CONTRACT NO. 62703				

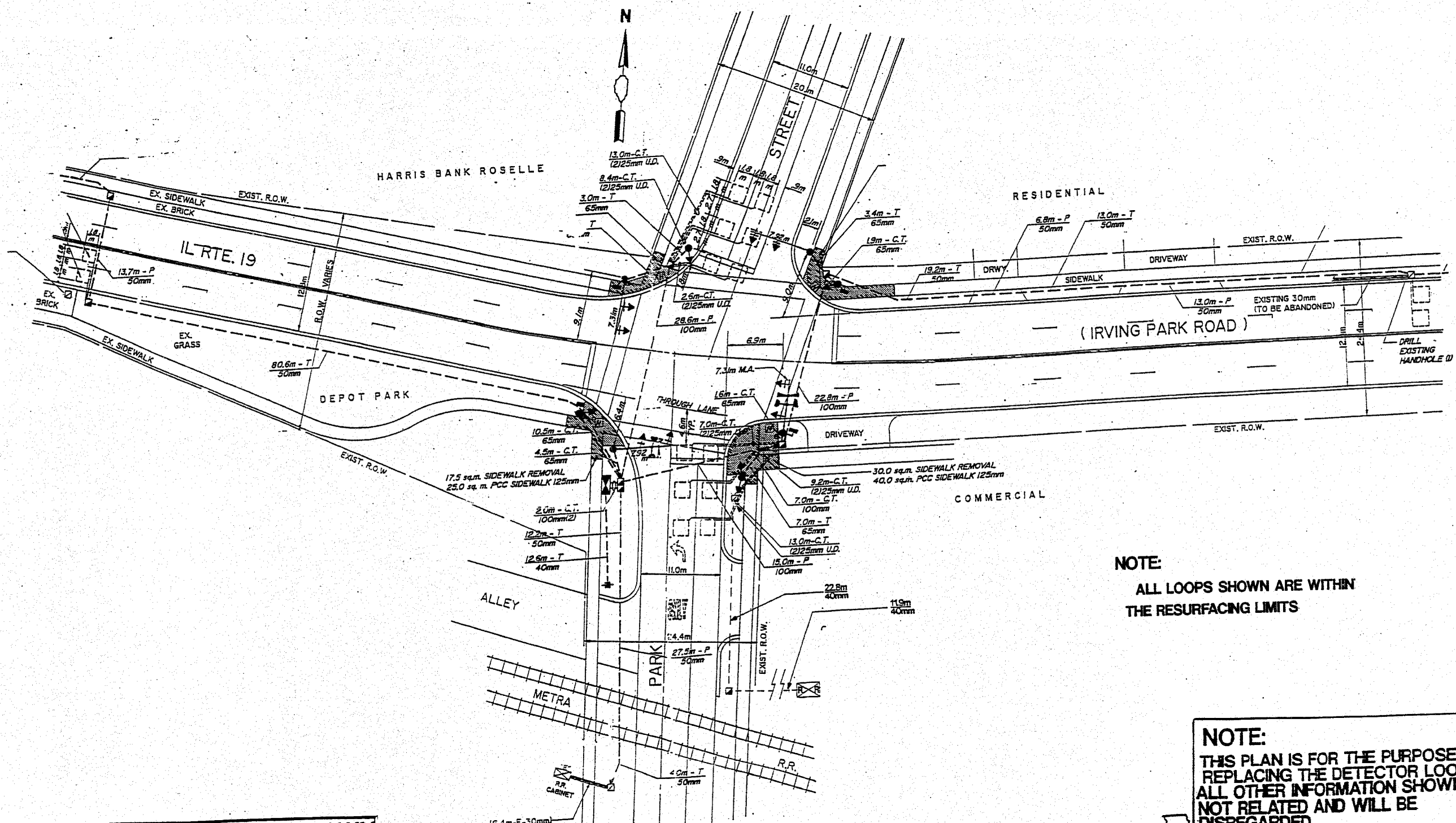

NOTE:
ALL LOOPS SHOWN ARE WITHIN THE RESURFACING LIMITS

NOTE:
THIS PLAN IS FOR THE PURPOSE OF REPLACING THE DETECTOR LOOPS. ALL OTHER INFORMATION SHOWN IS NOT RELATED AND WILL BE DISREGARDED.

PLACE ALL DETECTOR LOOPS AS SHOWN (WITHIN THE RESURFACING LIMITS)

CODE NO.	QUANTITY	UNIT	ITEM
3600600	514'	FOOT	DETECTOR LOOP REPLACEMENT

SCALE: T= DATE
DESIGNED BY: DRAWN BY: CHECKED BY:



ILLINOIS DEPARTMENT OF TRANSPORTATION
DETECTOR LOOPS AT:
IL RT 19 (IRVING PARK RD) & PARK STREET

P.A.D. RTE.	SECTION	COUNTY	TOTAL SHEETS	SHEET NO.
1321	C1&72SRS-8	DUPAGE	37	24
FED. ROAD DIST. NO.		ILLINOIS	FED. AID PROJECT	
CONTRACT NO. 62703				

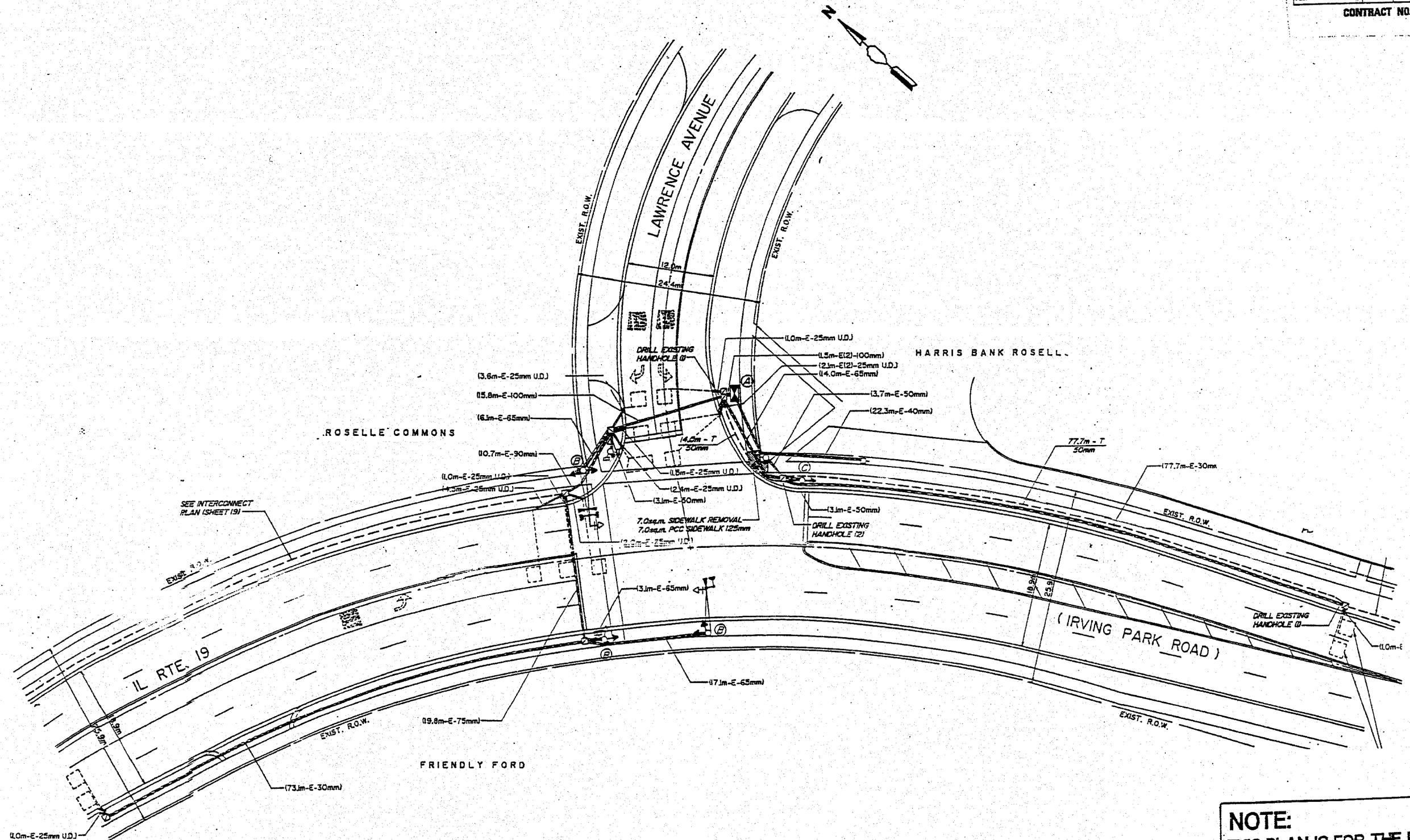

NOTE:
ALL LOOPS SHOWN ARE WITHIN RESURFACING LIMITS

NOTE:
THIS PLAN IS FOR THE PURPOSE OF REPLACING THE DETECTOR LOOPS, ALL OTHER INFORMATION SHOWN IS NOT RELATED AND WILL BE DISREGARDED.

PLACE ALL DETECTOR LOOPS AS SHOWN				
(WITHIN THE RESURFACING LIMITS)				
CODE NO.	QUANTITY	UNIT	ITEM	
8600600	492'	FOOT	DETECTOR LOOP REPLACEMENT	

SCALE: 1" =
DATE

DESIGNED BY:
DRAWN BY:
CHECKED BY:



ILLINOIS DEPARTMENT OF TRANSPORTATION
DETECTOR LOOPS AT:
**IL RT 19 (IRVING PARK RD)
& LAWRENCE AVENUE**

FAH RTE.	SECTION	COUNTY	TOTAL SHEETS	SHEET NO.
1321	(31&725)RS-8	DUPAGE	37	25
FED. ROAD DIST. NO.		ILLINOIS FED. AID PROJECT		

CONTRACT NO. 62703

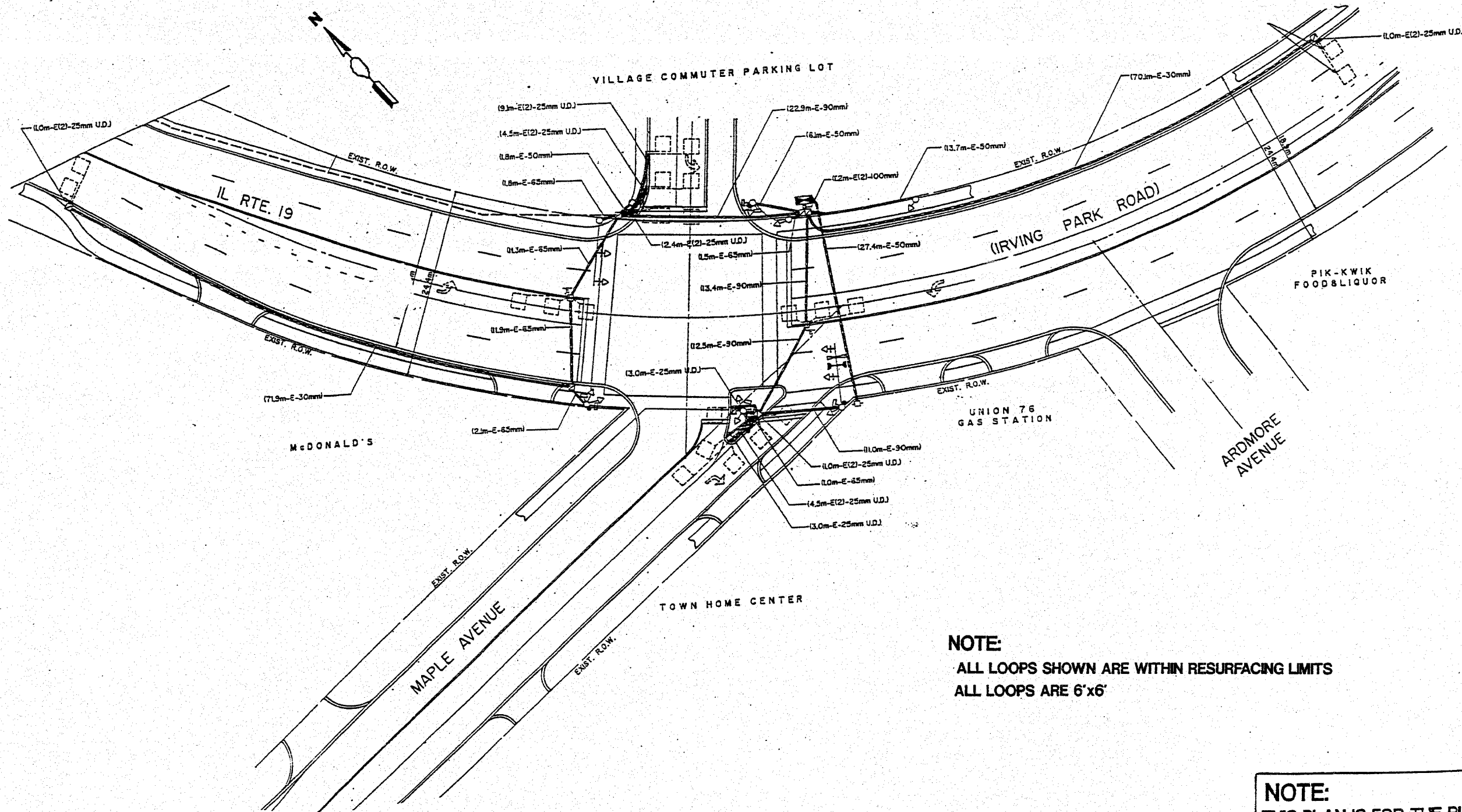

NOTE:
ALL LOOPS SHOWN ARE WITHIN RESURFACING LIMITS
ALL LOOPS ARE 6'x6'

NOTE:
THIS PLAN IS FOR THE PURPOSE OF
REPLACING THE DETECTOR LOOPS.
ALL OTHER INFORMATION SHOWN IS
NOT RELATED AND WILL BE
DISREGARDED.

PLACE ALL DETECTOR LOOPS AS SHOWN
(WITHIN THE RESURFACING LIMITS)

CODE NO.	QUANTITY	UNIT	ITEM
38600600	761	FOOT	DETECTOR LOOP REPLACEMENT

SCALE: 1"=
DATE

DESIGNED BY:
DRAWN BY:
CHECKED BY:

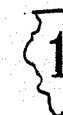

ILLINOIS DEPARTMENT OF TRANSPORTATION
DETECTOR LOOPS AT:
IL RT 19 (IRVING PARK RD)
& MAPLE AVENUE

SCHEDULE OF QUANTITIES
MAGNETIC DETECTOR AND LOOP DETECTOR REPLACEMENT

CODE	QUANTITY	UNIT	PAY ITEM
7301305	743	FOOT	ELECTRIC CABLE IN CONDUIT, LEAD-IN, NO. 14 1 PAIR
8500100	2	EACH	INDUCTIVE LOOP DETECTOR
3600100	132'	FOOT	DETECTOR LOOP, TYPE I
3600600	858	FOOT	DETECTOR LOOP REPLACEMENT
5000200	1	EACH	MAINTENANCE OF EXISTING TRAFFIC SIGNAL INSTALLATION
3150200		FOOT	TRENCH AND BACKFILL FOR ELECTRICAL WORK
7900200	10	EACH	DRILL EXISTING HANDHOLE
9502300	616'	FOOT	REMOVE ELECTRICAL CABLE FROM CONDUIT

PLAN	SECTION	COUNTY	TOTAL SHEETS
1321	(S1&72S)RS-8	DUPAGE	37 26
FED. ROAD DIST. NO. - ILLINOIS FED. AID PROJECT			
CONTRACT NO. 62703			

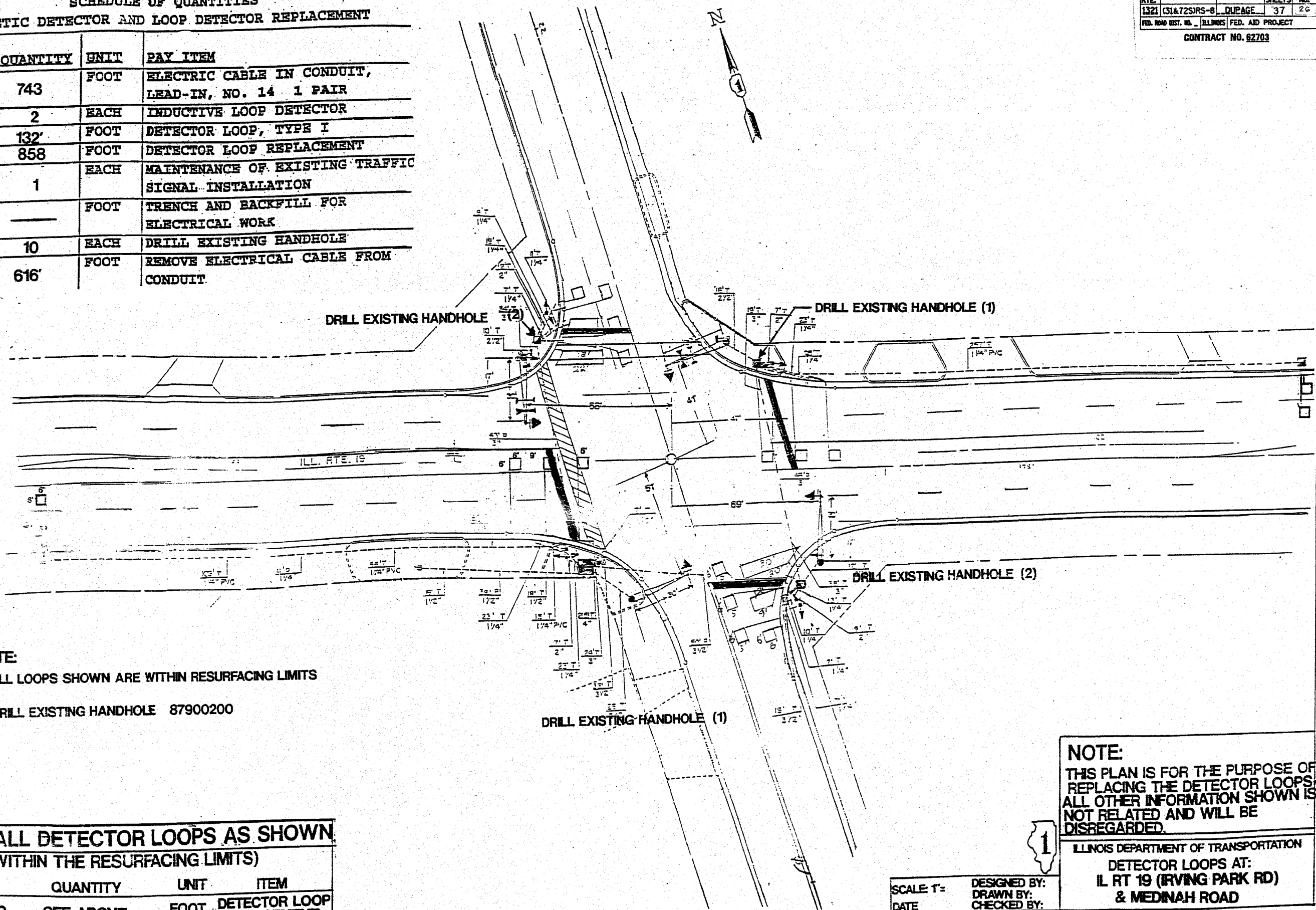

NOTE:
 ALL LOOPS SHOWN ARE WITHIN RESURFACING LIMITS
 DRILL EXISTING HANDHOLE 87900200

NOTE:
 THIS PLAN IS FOR THE PURPOSE OF REPLACING THE DETECTOR LOOPS; ALL OTHER INFORMATION SHOWN IS NOT RELATED AND WILL BE DISREGARDED.

PLACE ALL DETECTOR LOOPS AS SHOWN (WITHIN THE RESURFACING LIMITS)

CODE NO.	QUANTITY	UNIT	ITEM
3600600	SEE ABOVE	FOOT	DETECTOR LOOP REPLACEMENT

SCALE: 1" = 30'
 DATE: _____
 DESIGNED BY: _____
 DRAWN BY: _____
 CHECKED BY: _____



ILLINOIS DEPARTMENT OF TRANSPORTATION
 DETECTOR LOOPS AT:
 IL RT 19 (IRVING PARK RD)
 & MEDINAH ROAD

F.A.U. RTE.	SECTION	COUNTY	TOTAL SHEETS	SHEET NO.
1321	(31&72)RS-B	DUPAGE	37	26A
STA.		TO STA.		
FED. ROAD DIST. NO. 1 ILLINOIS FED. AID PROJECT				
CONTRACT NO. 62703				

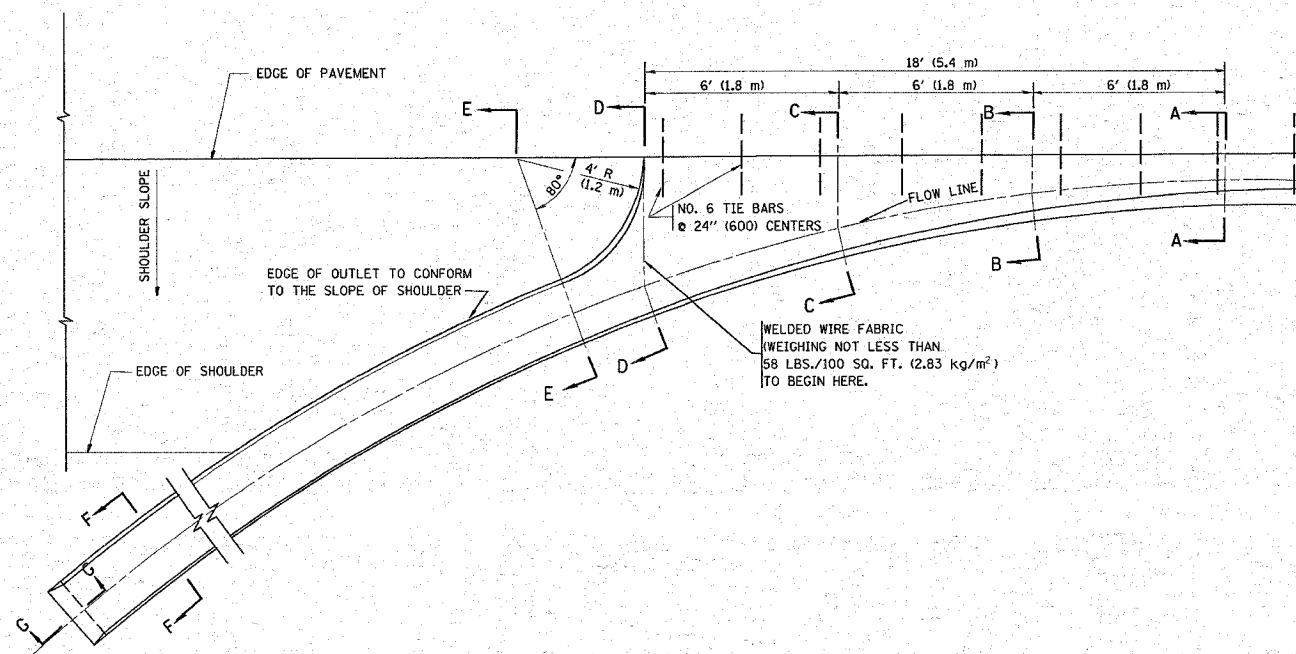

A-A *

* DIMENSIONS OF THE CURB & GUTTER AT SECTION A-A ARE SHOWN ON STATE STANDARD 606001. FOR DETAILS OF OUTLET FOR CONCRETE CURB & GUTTER, TYPE B-6.24 (B-15.60) SEE STATE STANDARD 606006.

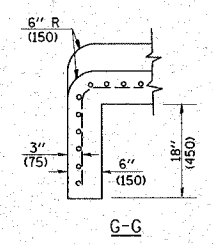
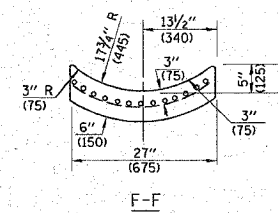
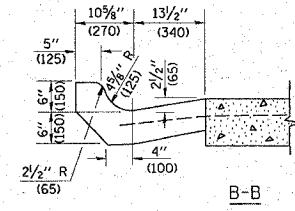
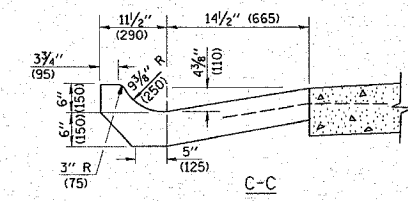
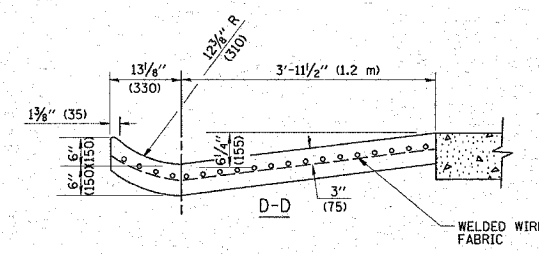
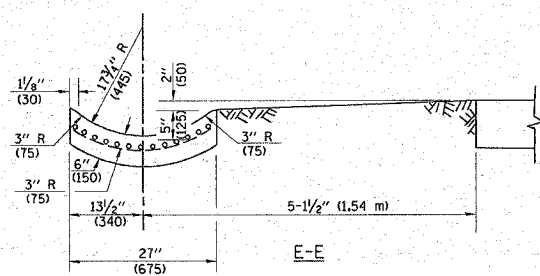

GENERAL NOTES

GUTTER OUTLET SHALL BE TIED TO THE PAVEMENT IN ACCORDANCE WITH DETAILS FOR LONGITUDINAL CONSTRUCTION JOINT SHOWN ON STANDARD 420001.

TIE BARS SHALL BE NO. 20 (NO.6) AT 24\" (600) CENTERS UNLESS OTHERWISE SHOWN.

IF THE AVERAGE GRADE OF PAVEMENT FOR THE DISTANCE FROM SECTION A-A TO D-D EXCEEDS 2%, THIS DISTANCE SHALL BE INCREASED 6\" (1.8 m) FOR EACH 1% INCREASE IN GRADE.

QUANTITIES

FOR SECTION A-A TO E-E AND CURTAIN WALL= 1.25 CU. YDS. (0.96 m³) CLASS SI CONCRETE (OUTLET) FOR 9\" (225) PAV'T.
1.27 CU. YDS. (0.96 m³) CLASS SI CONCRETE (OUTLET) FOR 10\" (250) PAV'T.
FOR SECTION F-F= 0.045 CU. YDS. (0.03 m³) CLASS SI CONCRETE PER FT. (M).

ALL DIMENSIONS ARE IN INCHES (MILLIMETERS) UNLESS OTHERWISE SHOWN.

REVISIONS	
NAME	DATE
M. DE YONG	8/4/86
R. SHAH	09/09/94
R. SHAH	10/25/94
E. GOMEZ	12/21/00

ILLINOIS DEPARTMENT OF TRANSPORTATION

OUTLET FOR CONCRETE CURB AND GUTTER

SCALE: VERT. NONE
HORIZ.

DRAWN BY
CHECKED BY

BD600-01 (BD-03)

PLOT DATE = 3/18/2008
FILE NAME = \\sainfrs\user\galbamb\Desk\top\bd603.dgn
PLOT SCALE = 500000 / IN.
USER NAME = galbamb

F.A.U. RTE.	SECTION	COUNTY	TOTAL SHEETS	SHEET NO.
1321	(31&72S)RS-8	DUPAGE	37	268
STA.		TO STA.		
FED. ROAD DIST. NO. 1		ILLINOIS FED. AID PROJECT		
CONTRACT NO. 62703				

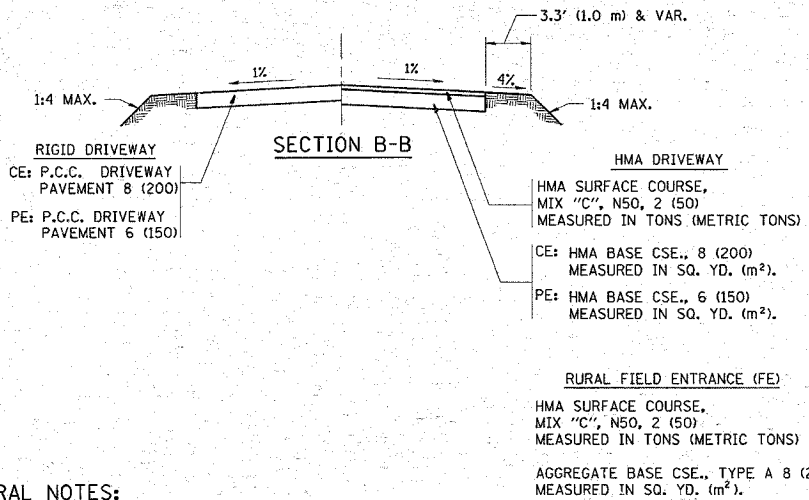
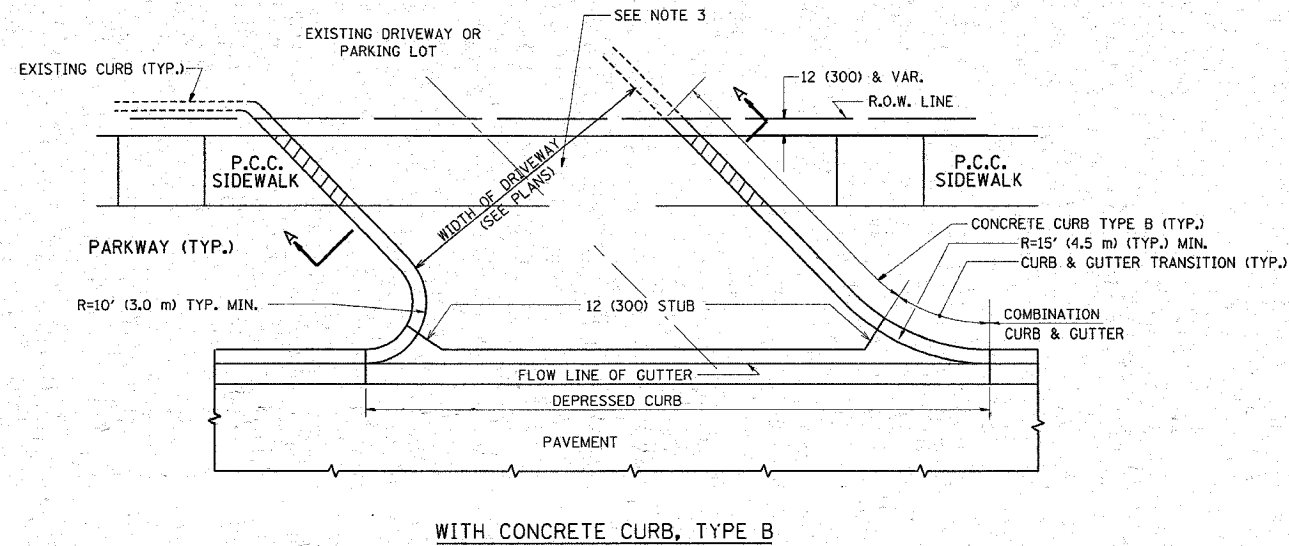
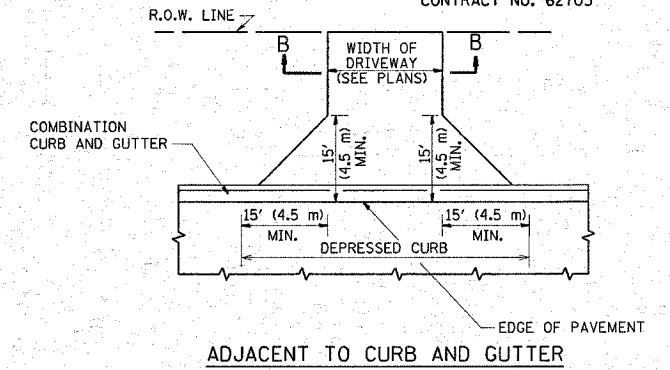
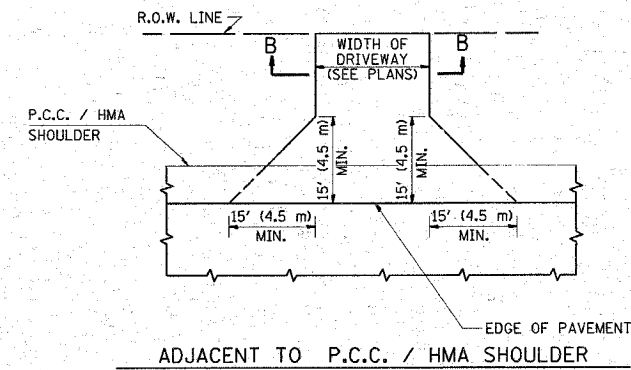
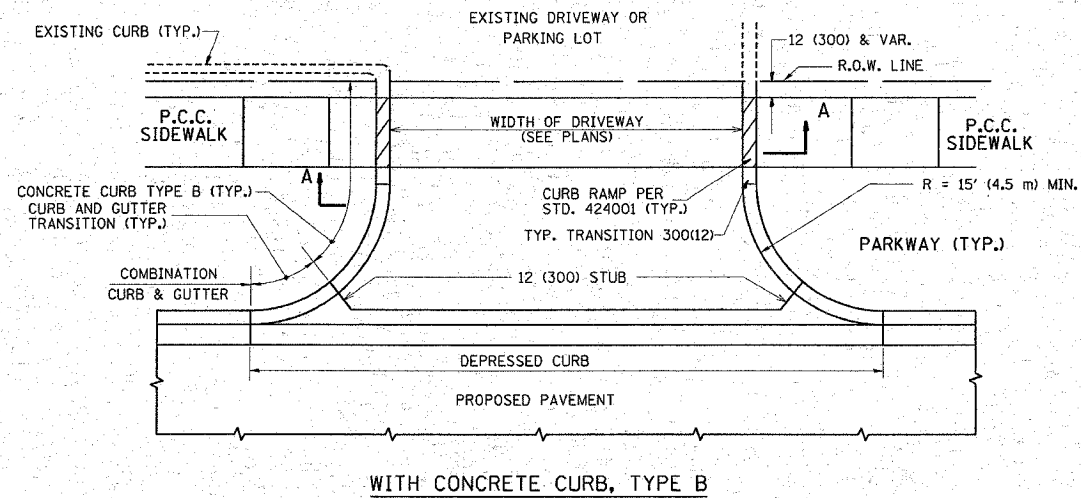

GENERAL NOTES:

DRIVEWAY SLOPES, LOCATIONS, & GEOMETRIC LAYOUT SHALL BE IN ACCORDANCE WITH THE LATEST EDITION OF THE "HANDBOOK FOR POLICY ON PERMITS FOR ACCESS DRIVEWAYS TO STATE HIGHWAYS". FOR FURTHER LAYOUT REQUIREMENTS, REFER TO ILLUSTRATIONS IN THE PERMIT HANDBOOK. DRIVEWAYS SHALL BE REPLACED IN KIND, UNLESS OTHERWISE NOTED ON THE PLANS.

COMMERCIAL DRIVEWAYS SHALL BE CONSTRUCTED WITH CONCRETE CURB, TYPE B RETURNS EXCEPT WHEN THE SIDEWALK EDGE IS 4 FEET (1.2 METERS) OR LESS FROM THE BACK OF CURB, CONSTRUCT A FLARE DRIVEWAY WITHOUT CURB.

THE RESIDENT ENGINEER SHALL CONTACT THE TRAFFIC PERMIT OFFICE AT 847/ 705-4131 FOR ANY QUESTIONS ON DRIVEWAYS SHOWN IN THE PLANS; SPECIFICALLY IN REFERENCE TO ADDITIONAL AND/OR RELOCATION/REMOVAL OF A DRIVEWAY.

COMBINATION CONCRETE CURB & GUTTER SHALL BE MEASURED STRAIGHT ACROSS THE DRIVEWAY. NO ADDITIONAL COMPENSATION WILL BE ALLOWED FOR THE CURB & GUTTER TRANSITION.

1 (25) PREFORMED EXPANSION JOINT FILLER WILL NOT BE PAID SEPARATELY, BUT SHALL BE CONSIDERED INCLUDED IN THE COST OF THE P.C.C. DRIVEWAY PAVEMENT OR P.C.C. SIDEWALK.

WHEN THE P.C.C. SIDEWALK EXTENDS THROUGH THE DRIVEWAY, THE THICKNESS OF THE SIDEWALK IN THE DRIVEWAY AREA SHALL BE THE SAME AS THE DRIVEWAY THICKNESS. SIDEWALK WILL BE PAID FOR AS P.C.C. SIDEWALK OF THE THICKNESS SPECIFIED. SIDEWALK CROSS SLOPE THRU DRIVEWAY AREA TO BE A MAXIMUM OF 1:50.

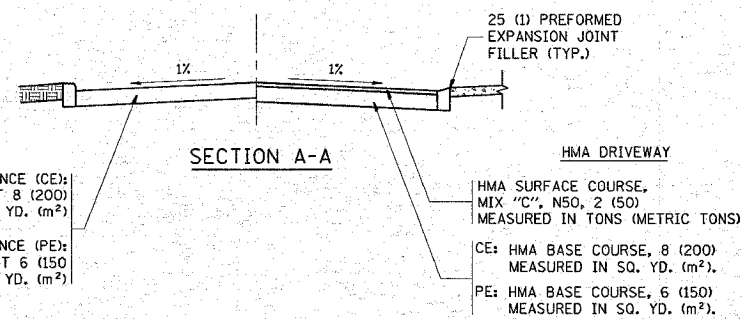

ALL DIMENSIONS ARE IN INCHES (MILLIMETERS) UNLESS OTHERWISE NOTED

REVISIONS		ILLINOIS DEPARTMENT OF TRANSPORTATION
NAME	DATE	
R. SHAH	11-04-95	DRIVEWAY DETAILS DISTANCE BETWEEN R.O.W. AND FACE OF CURB & EDGE OF SHOULDER >= 15' (4.5 m)
J. POLLASTRINI	08-12-96	
J. POLLASTRINI	12-14-96	
A. ABBAS	03-21-97	
T. HOLTZ	04-08-97	
M. GOMEZ	04-06-01	
P. LaFLEUR	04-15-03	
R. BORO	01-01-07	

SCALE: VERT. NONE
HORIZ.

DRAWN BY
CHECKED BY

PLOT DATE = 3/31/2008
FILE NAME = \\distrib\p2\users\lgabernib\Desktop\bd11.dgn
USER = lgabernib
SCALE = 3/8" = 1'-0"

F.A.U. RTE.	SECTION	COUNTY	TOTAL SHEETS	SHEET NO.
1321	(31&72)SRS-8	DUPAGE	37	26C
STA.		TO STA.		
FED. ROAD DIST. NO. 1 ILLINOIS FED. AID PROJECT				
CONTRACT NO. 62703				

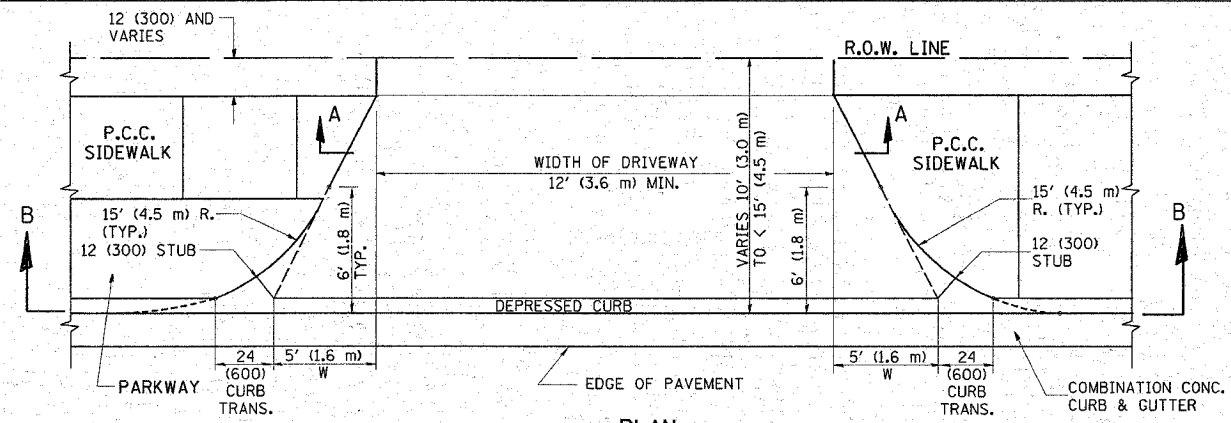

PLAN
10' (3.0 m) TO < 15' (4.5 m)

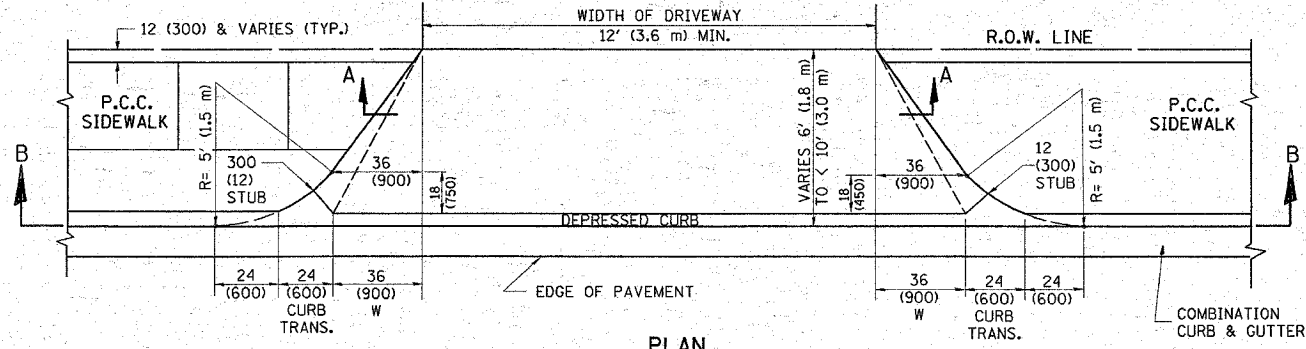

PLAN
6' (1.8 m) TO < 10' (3.0 m)

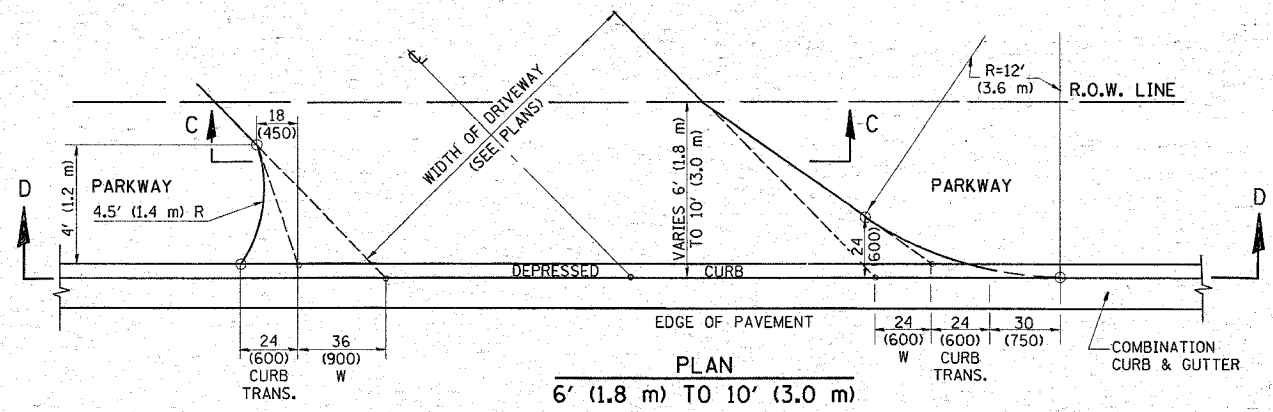

PLAN
6' (1.8 m) TO 10' (3.0 m)

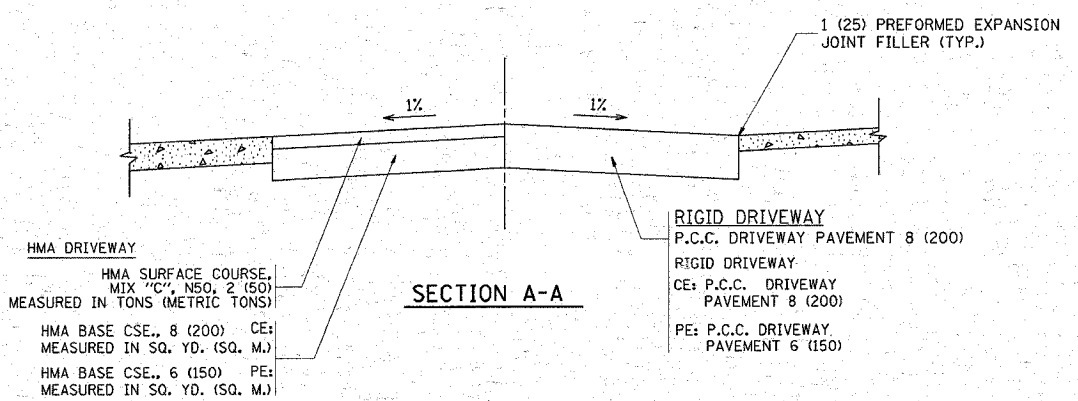

SECTION A-A

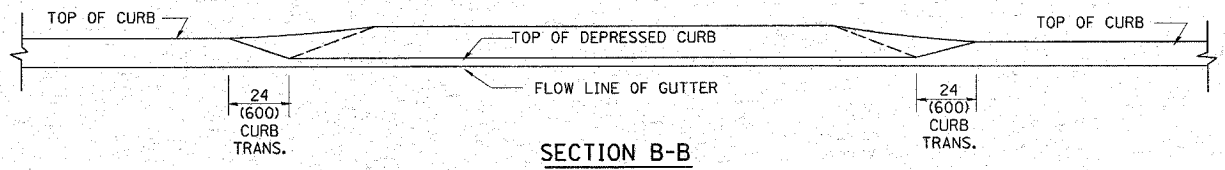

SECTION B-B

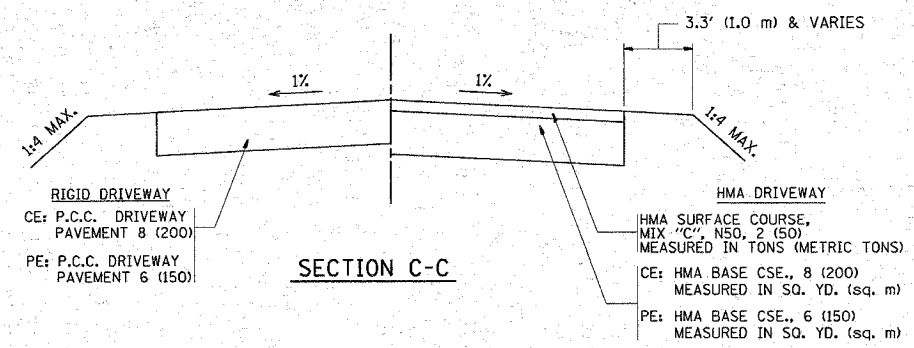

SECTION C-C

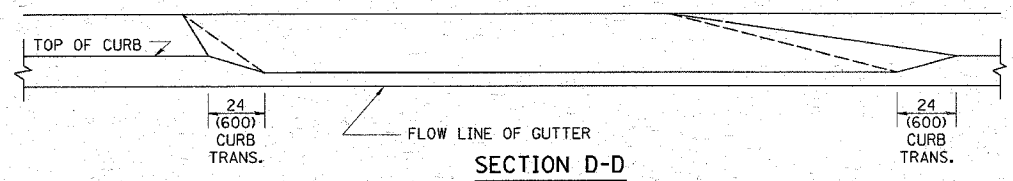

SECTION D-D

GENERAL NOTES

DRIVEWAY SLOPES, LOCATIONS, & GEOMETRIC LAYOUT SHALL BE IN ACCORDANCE WITH THE LATEST EDITION OF THE "HANDBOOK FOR POLICY ON PERMITS FOR ACCESS DRIVEWAYS TO STATE HIGHWAYS". FOR FURTHER LAYOUT REQUIREMENTS, REFER TO ILLUSTRATION 10 IN THE PERMIT HANDBOOK. WHERE SIDEWALKS EXIST, DRIVEWAYS SHALL BE REPLACED WITH RIGID PAVEMENT. WHERE NO SIDEWALKS EXIST, DRIVEWAYS SHALL BE REPLACED IN KIND. SIDEWALK CROSS SLOPE THRU DRIVEWAY AREA TO BE A MAXIMUM OF 1:50.

WHEN THE DISTANCE BETWEEN R.O.W. AND THE BACK OF CURB IS EQUAL TO OR LESS THAN 8' (2.4 m), THE P.C.C. SIDEWALK SHALL EXTEND TO THE BACK OF CURB.

THE RESIDENT ENGINEER SHALL CONTACT THE TRAFFIC PERMIT OFFICE AT 847/705-4131 FOR ANY QUESTIONS ON DRIVEWAYS SHOWN IN THE PLANS; SPECIFICALLY IN REFERENCE TO ADDITIONAL AND/OR RELOCATION/REMOVAL OF A DRIVEWAY.

COMBINATION CONCRETE CURB & GUTTER SHALL BE MEASURED STRAIGHT ACROSS THE DRIVEWAY. NO ADDITIONAL COMPENSATION WILL BE ALLOWED FOR THE CURB & GUTTER TRANSITION.

THE 1 (25) PREFORMED EXPANSION JOINT FILLER WILL NOT BE PAID SEPARATELY, BUT SHALL BE CONSIDERED INCLUDED IN THE COST OF THE P.C.C. DRIVEWAY PAVEMENT OR P.C.C. SIDEWALK.

"W" VARIES FROM 36 (900) TO 5' (1.5 m) PROPORTIONAL TO THE LENGTH (L), FROM 6' (1.8 m) TO 10' (3 m).

ALL DIMENSIONS ARE IN INCHES (MILLIMETERS) UNLESS OTHERWISE NOTED.

ILLINOIS DEPARTMENT OF TRANSPORTATION

DRIVEWAY DETAILS
DISTANCE BETWEEN ROW AND FACE OF CURB < 15' (4.5 m)

REVISIONS	
NAME	DATE
R. SHAH	11/06/95
J. POLLASTRINI	08/12/96
J. POLLASTRINI	12/14/96
A. ABBAS	03/21/97
T. HOLTZ	04/08/97
M. GOMEZ	04/06/01
P. LAFLEUR	04/15/03
R. BORO	01/01/07

SCALE: VERT. NONE
HORIZ.

DRAWN BY
CHECKED BY

PLOT DATE = 2/21/2008
FILE NAME = \\saintfrancis\users\lgallagher\Desktop\ltd82.dgn
PLOT SCALE = 3/8"=1'-0"
USER NAME = gellbenn

F.A.U. RTE.	SECTION	COUNTY	TOTAL SHEETS	SHEET NO.
1321	(31&72)SIRS-8	DUPAGE	37	27
STA.		TO STA.		
FED. ROAD DIST. NO. 1		ILLINOIS	FED. AID PROJECT	

CONTRACT NO. 62703

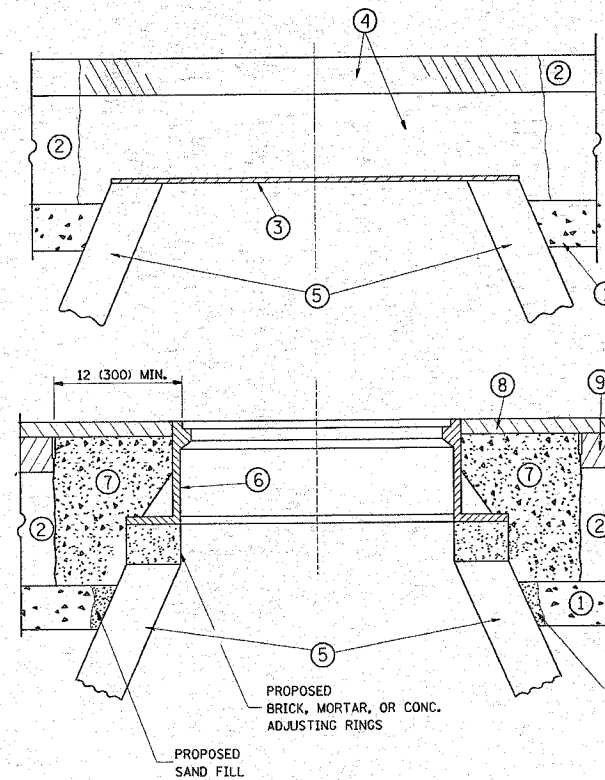

CONSTRUCTION PROCEDURES

STAGE 1 (BEFORE PAVEMENT MILLING)

- A) REMOVE A MINIMUM OF 12 (300) OF THE PAVEMENT FROM AROUND THE STRUCTURE.
- B) REMOVE THE EXISTING FRAME AND LID FROM THE STRUCTURE.
- C) COVER THE STRUCTURE OPENING WITH A 36 (900) DIAMETER METAL PLATE.
- D) BACKFILL WITH CRUSHED STONE AND A MINIMUM 1 1/2 (40) THICK HMA SURFACE MIX APPROVED BY THE ENGINEER.

STAGE 2 (AFTER PAVEMENT MILLING)

- A) REMOVE THE HMA SURFACE MIX AND CRUSHED STONE.
- B) INSTALL THE FRAME AND LID; ADJUST THE FRAME TO ITS FINAL SURFACE ELEVATION.
- C) THE SURROUNDING SPACE SHALL BE FILLED WITH CLASS SI CONCRETE, OR HMA SURFACE COURSE OR HMA BINDER COURSE TO THE ELEVATION OF THE SURFACE OF THE EXISTING BASE COURSE OR THE BINDER COURSE.

THE PROCEDURE EXPLAINED ABOVE SHALL CONFORM TO THE APPLICABLE PORTIONS OF SECTIONS 353, 406, 602, AND 603 OF THE STANDARD SPECIFICATIONS.

LEGEND

- | | |
|--|--|
| ① SUB-BASE GRANULAR MATERIAL | ⑥ FRAME AND LID (SEE NOTES) |
| ② EXISTING PAVEMENT | ⑦ CLASS SI CONCRETE, HMA SURFACE COURSE OR HMA BINDER COURSE |
| ③ 36 (900) DIAMETER METAL PLATE | ⑧ PROPOSED HMA SURFACE COURSE |
| ④ PROPOSED CRUSHED STONE AND HMA SURFACE MIX | ⑨ PROPOSED HMA BINDER COURSE |
| ⑤ EXISTING STRUCTURE | |

LOCATION OF STRUCTURES:

THE CONTRACTOR WILL BE REQUIRED TO KEEP A RECORD OF THE LOCATIONS OF THE BURIED STRUCTURES ACCORDING TO THE STATION AND DISTANCE LEFT OR RIGHT OF THE CENTERLINE OF PAVEMENT. UPON COMPLETION OF THE WORK, THE CONTRACTOR WILL DELIVER THE RECORD TO THE ENGINEER.

BASIS OF PAYMENT: THIS WORK WILL BE PAID FOR AT THE CONTRACT UNIT PRICE PER EACH FOR "FRAMES AND LIDS TO BE ADJUSTED, SPECIAL"

NEW FRAMES AND LIDS, WHEN SPECIFIED, WILL BE PAID FOR SEPARATELY.

NOTES:

EXISTING BROKEN FRAMES AND LIDS SHALL BE REMOVED AND DISPOSED OF BY THE CONTRACTOR AND SHALL BE REPLACED AS DIRECTED BY THE ENGINEER. REPLACEMENT FRAMES AND LIDS WILL BE PAID FOR IN ACCORDANCE WITH ARTICLE 109.04 OF THE STANDARD SPECIFICATIONS UNLESS A SEPARATE PAY ITEM HAS BEEN PROVIDED.

IF THE EXISTING LIDS ARE OPEN, THE FRAME WILL BE ADJUSTED TO THE ELEVATION OF THE MILLED PAVEMENT SURFACE PRIOR TO THE MILLING OPERATION. THE FRAME WILL NOT BE REMOVED AND COVERED BY THE METAL PLATE.

CITY OF CHICAGO CASTINGS ARE THE PROPERTY OF THE CITY AND THE CONTRACTOR SHALL NOTIFY THE CITY FOR REMOVAL AND DISPOSITION OF THE CASTINGS.

THE METAL PLATE USED TO COVER THE STRUCTURE SHALL REMAIN THE PROPERTY OF THE CONTRACTOR.

WHEN STRUCTURES ARE TO BE ADJUSTED OR RECONSTRUCTED, THE LOWERING AND RAISING OF THE FRAMES AND LIDS WILL NOT BE PAID FOR SEPARATELY BUT WILL BE INCLUDED IN THE COST OF THE CORRESPONDING PAY ITEM.

DETAILS FOR FRAMES AND LIDS ADJUSTMENT WITH MILLING

ALL DIMENSIONS ARE IN INCHES (MILLIMETERS) UNLESS OTHERWISE SHOWN

REVISIONS	
NAME	DATE
R. SHAH	10/25/94
R. SHAH	01/30/95
R. SHAH	03/10/95
A. ABBAS	03/21/97
R. WIEDEMAN	05/14/04
R. BORO	01/01/07

ILLINOIS DEPARTMENT OF TRANSPORTATION
DETAILS FOR FRAMES AND LIDS ADJUSTMENT WITH MILLING

SCALE: VERT. NONE
HORIZ. NONE

DRAWN BY

CHECKED BY

BD600-03 (BD-8)

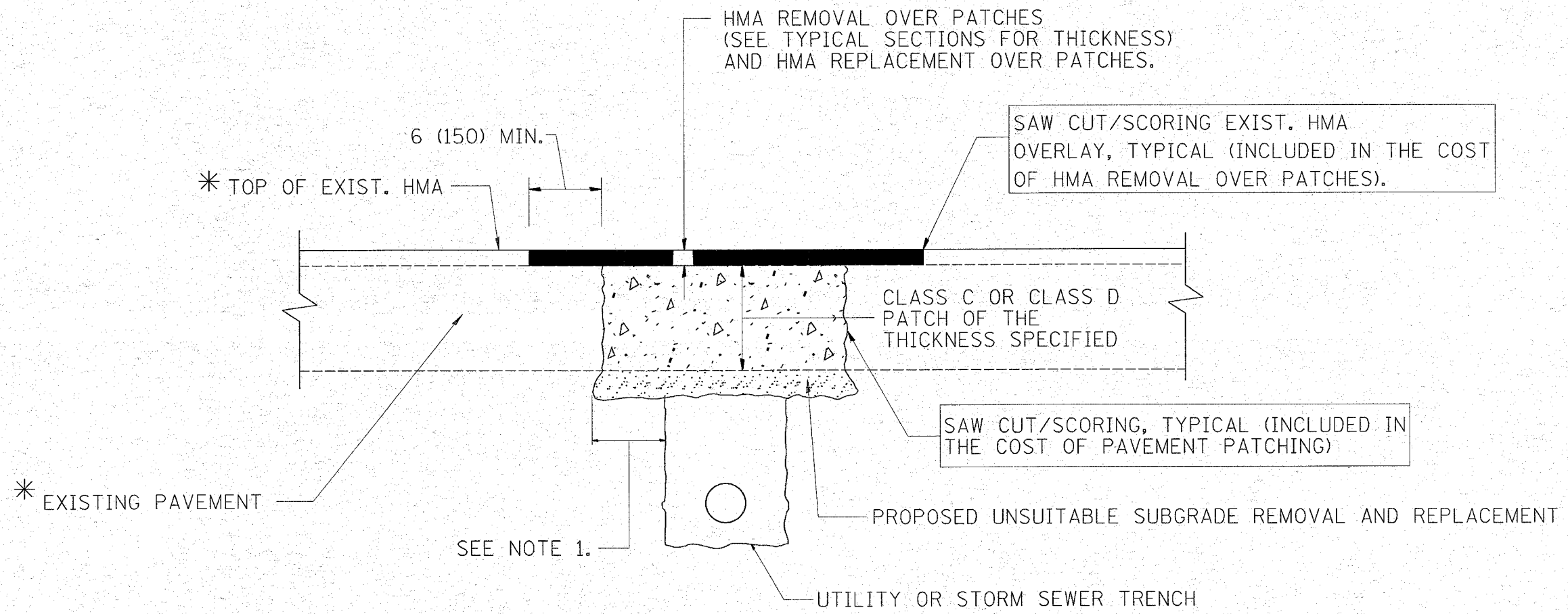

* SEE TYPICAL SECTIONS FOR THICKNESS AND MATERIALS

NOTES:

1. THE WIDTH OF THE FULL DEPTH PATCH OVER A TRENCH SHALL BE 12 (300) WIDER ON EACH SIDE OF THE TRENCH.
2. FOR METHOD OF MEASUREMENT AND BASIS OF PAYMENT, SEE RECURRING SPECIAL PROVISION "PATCHING WITH HOT-MIX ASPHALT OVERLAY REMOVAL".

SEQUENCE OF CONSTRUCTION

1. REMOVE THE EXISTING HMA MATERIAL OVER THE AREA TO BE PATCHED.
2. REMOVE AND REPLACE FULL DEPTH PATCHES
3. REPLACE HMA MATERIAL OVER THE AREA TO BE PATCHED.

ALL DIMENSIONS ARE IN INCHES (MILLIMETERS) UNLESS OTHERWISE SHOWN.

REVISIONS	
NAME	DATE
R. SHAH	10/25/94
R. SHAH	01/14/95
R. SHAH	03/23/95
R. SHAH	04/24/95
A. HOUSEH	03/15/96
A. ABBAS	03/21/97
A. ABBAS	01/20/98
ART ABBAS	04/27/98
R. BORO	01/01/07
R. BORO	09/04/07

ILLINOIS DEPARTMENT OF TRANSPORTATION

PAVEMENT PATCHING FOR HMA SURFACED PAVEMENT

SCALE: VERT. NONE
HORIZ.

DRAWN BY

CHECKED BY

BD400-04 (BD-22)

F.A.U. RTE.	SECTION	COUNTY	TOTAL SHEETS	SHEET NO.
1321	(31&72S)RS-8	DUPAGE	37	29
STA.		TO STA.		
FED. ROAD DIST. NO. 1		ILLINOIS FED. AID PROJECT		

CONTRACT NO. 62703

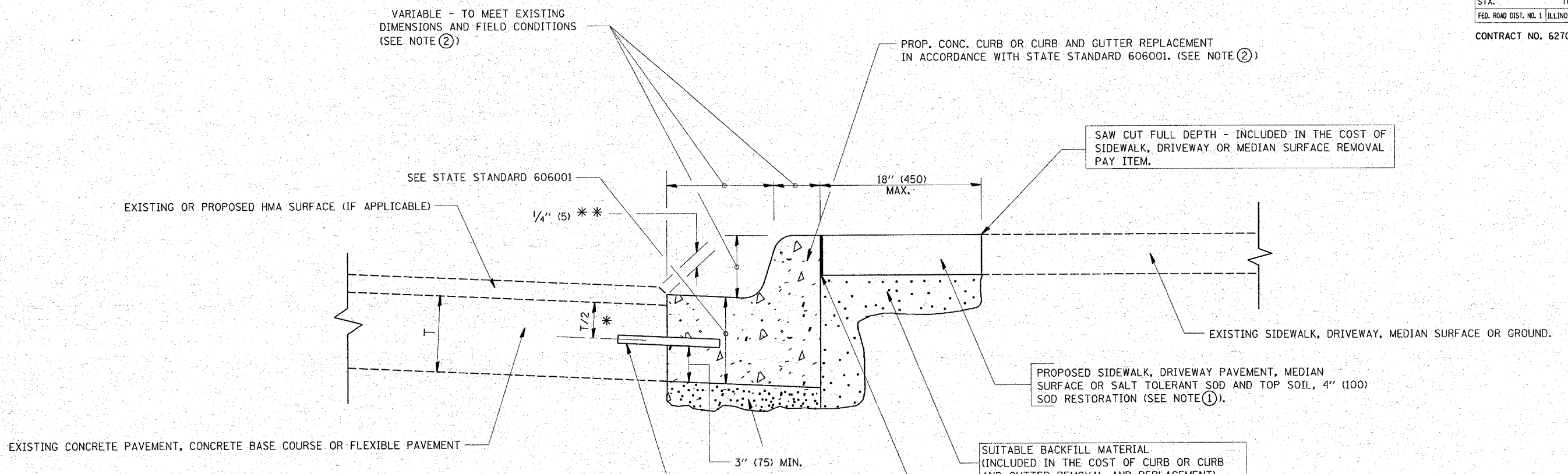

- * 3" (75) MINIMUM FROM TOP AND BOTTOM OF THE CONCRETE PAVEMENT OR BASE COURSE.
 - * * IF THE FINAL SURFACE OF THE PAVEMENT IS CONCRETE, THE GUTTER IS TO BE FLUSH WITH THE PAVEMENT.
- NOTE: ① SIDEWALK, DRIVEWAY PAVEMENT OR MEDIAN SURFACE SHALL BE SIMILAR TO THE MATERIAL BEING REMOVED AND WILL BE PAID FOR SEPARATELY.
- SALT TOLERANT SOD AND TOP SOIL, 4" (100) RESTORATION WILL NOT BE PAID FOR SEPARATELY, BUT SHALL BE INCLUDED IN THE COST OF CURB OR CURB AND GUTTER REMOVAL AND REPLACEMENT.
- ② CURB OR CURB AND GUTTER REPLACEMENT SHALL MATCH THE SHAPE OF THE EXISTING CURB OR CURB AND GUTTER UNLESS OTHERWISE SPECIFIED.
 - ③ FOR CURB OR CURB AND GUTTER REMOVAL AND REPLACEMENT ADJACENT TO FLEXIBLE PAVEMENT DELETE EPOXY COATED TIE BARS.
 - ④ LONGITUDINAL BARS, IF ENCOUNTERED IN THE EXISTING CURB OR CURB AND GUTTER, ARE NOT TO BE REPLACED. CUTTING AND REMOVING LONGITUDINAL BARS SHALL BE INCLUDED IN THE COST OF CURB OR CURB AND GUTTER REMOVAL AND REPLACEMENT.
 - ⑤ THE COST OF HMA SURFACE REMOVAL IN THE EXISTING GUTTER FLAG SHALL BE INCLUDED IN THE COST OF THE CURB AND GUTTER REMOVAL AND REPLACEMENT.
 - ⑥ THE REMOVAL AND REPLACEMENT OF THE EXISTING CURB OR CURB AND GUTTER SHALL BE DONE IN ACCORDANCE WITH THE APPLICABLE PORTIONS OF SECTION 440 AND 606 OF THE STANDARD SPECIFICATIONS.
 - ⑦ THE LOCATIONS OF REMOVAL AND REPLACEMENT OF EXISTING CURB OR CURB AND GUTTER SHALL BE DETERMINED BY THE RESIDENT ENGINEER AT THE TIME OF CONSTRUCTION.

- PROPOSED CONC. CURB OR CURB AND GUTTER REPLACEMENT IN ACCORDANCE WITH STATE STANDARD 606001. (SEE NOTE ②)
- SAW CUT FULL DEPTH - INCLUDED IN THE COST OF SIDEWALK, DRIVEWAY OR MEDIAN SURFACE REMOVAL PAY ITEM.
- EXISTING SIDEWALK, DRIVEWAY, MEDIAN SURFACE OR GROUND.
- PROPOSED SIDEWALK, DRIVEWAY PAVEMENT, MEDIAN SURFACE OR SALT TOLERANT SOD AND TOP SOIL, 4" (100) SOD RESTORATION (SEE NOTE ①).
- SUITABLE BACKFILL MATERIAL (INCLUDED IN THE COST OF CURB OR CURB AND GUTTER REMOVAL AND REPLACEMENT)
- PROPOSED 3/4" (20) PREFORMED EXPANSION JOINT AT CONCRETE SIDEWALKS, DRIVEWAYS, AND MEDIANS. (INCLUDED IN THE COST OF CURB OR CURB AND GUTTER REMOVAL AND REPLACEMENT.)
- UNSUITABLE SUB-BASE MATERIAL TO BE REMOVED, IF DIRECTED BY THE ENGINEER, SHALL BE REPLACED WITH EITHER SUB-BASE GRANULAR MATERIAL, TYPE B OR ADDITIONAL THICKNESS OF CONCRETE.
- REMOVAL AND REPLACEMENT 4" (100) OR LESS IS INCLUDED IN THE COST OF CURB OR CURB AND GUTTER REMOVAL AND REPLACEMENT.
- REMOVAL AND REPLACEMENT IN EXCESS OF 4" (100) WILL BE PAID FOR IN ACCORDANCE WITH ARTICLE 109.04 OF THE STANDARD SPECIFICATIONS.
- PROPOSED #6 (20) EPOXY COATED TIE BARS 24" (600) LONG AT 24" (600) CENTERS WILL NOT BE PAID FOR SEPARATELY. DELETE EPOXY COATED TIE BARS IF EXISTING TIE BARS ARE USUABLE AS DETERMINED BY THE ENGINEER. (SEE NOTE ③).

BASIS OF PAYMENT:
 THIS WORK WILL BE PAID FOR AT THE CONTRACT UNIT PRICE PER FOOT (METER) FOR "CURB REMOVAL AND REPLACEMENT" OR "COMBINATION CONCRETE CURB AND GUTTER REMOVAL AND REPLACEMENT".

ALL DIMENSIONS ARE IN INCHES (MILLIMETERS) UNLESS OTHERWISE SHOWN.

REVISIONS	
NAME	DATE
A. HOUSEH	03/11/94
R. SHAH	02/24/95
R. SHAH	03/02/95
R. SHAH	08/19/96
R. SHAH	09/12/96
R. SHAH	09/19/96
R. SHAH	10/03/96
A. ABBAS	03/21/97
M. GOMEZ	01/22/01
R. BORO	01/01/07

ILLINOIS DEPARTMENT OF TRANSPORTATION
 CURB OR CURB AND GUTTER REMOVAL AND REPLACEMENT
 SCALE: VERT. NONE
 HORIZ.
 DRAWN BY
 CHECKED BY
 BD600-06 (BD-24)

CURB OR CURB AND GUTTER REMOVAL AND REPLACEMENT

PLOT DATE = 3/4/2008
 FILE NAME = \\saint\c2\users\galbarr\Desk\top\bd24.dgn
 PLOT SCALE = 80.000 / IN.
 USER NAME = galbarr

F.A.U. RTE.	SECTION	COUNTY	TOTAL SHEETS	SHEET NO.
1321	(31&72SRS-8	DUPAGE	37	30
STA.		TO STA.		
FED. ROAD DIST. NO. 1		ILLINOIS FED. AID PROJECT		
CONTRACT NO. 62703				

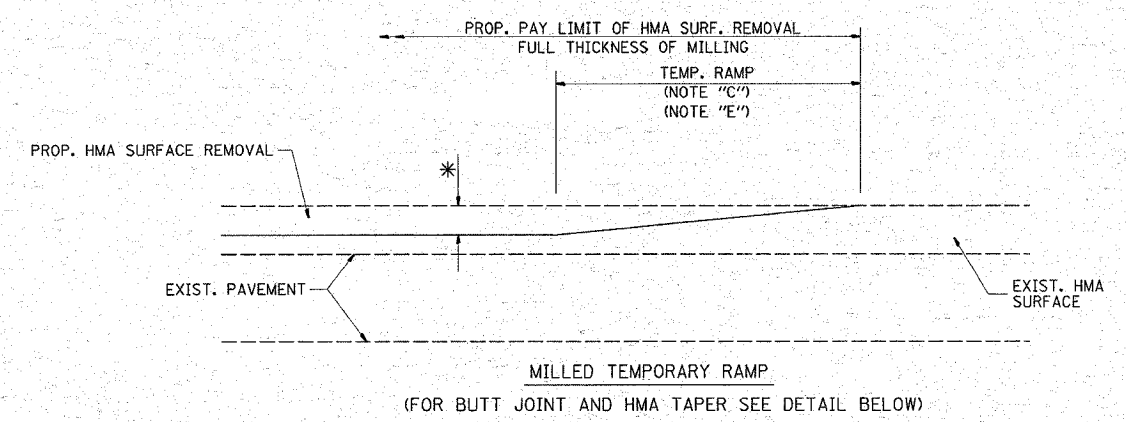

OPTION 1

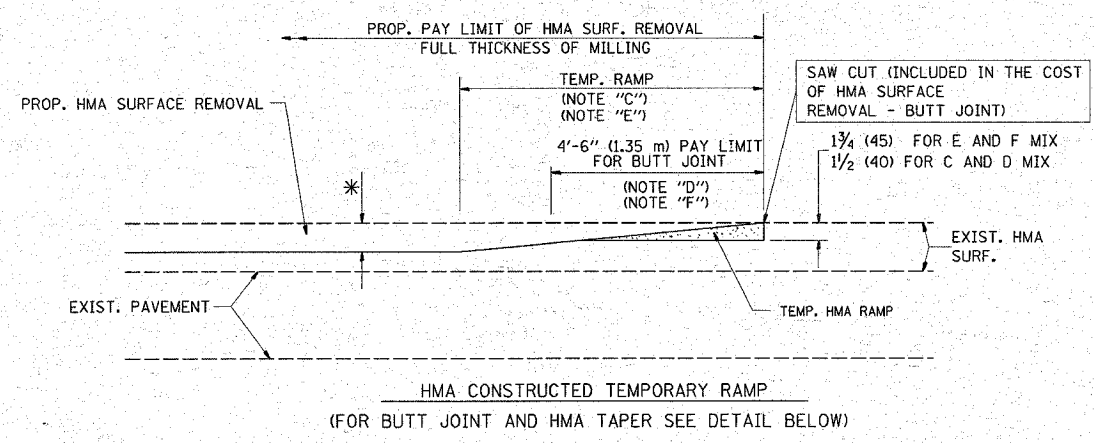

OPTION 2
TYPICAL TEMPORARY RAMP

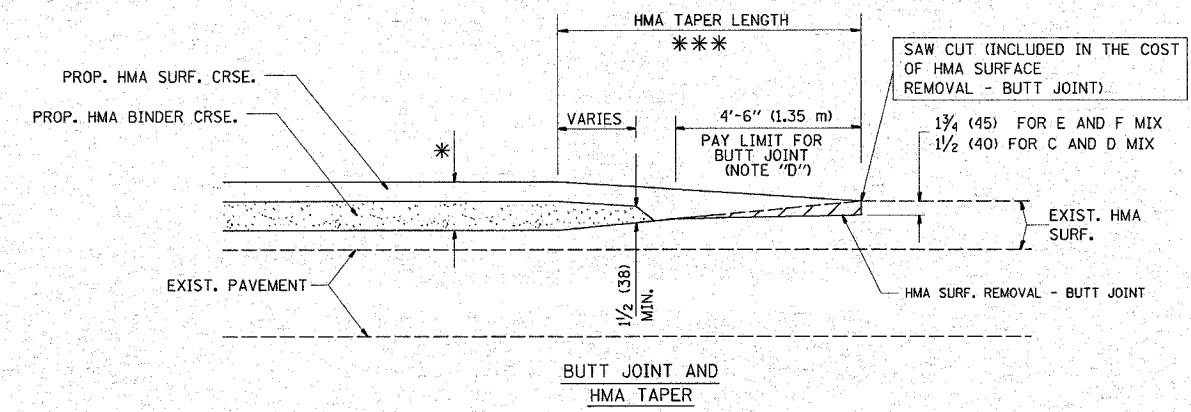

TYPICAL BUTT JOINT AND HMA TAPER FOR MILLING AND RESURFACING

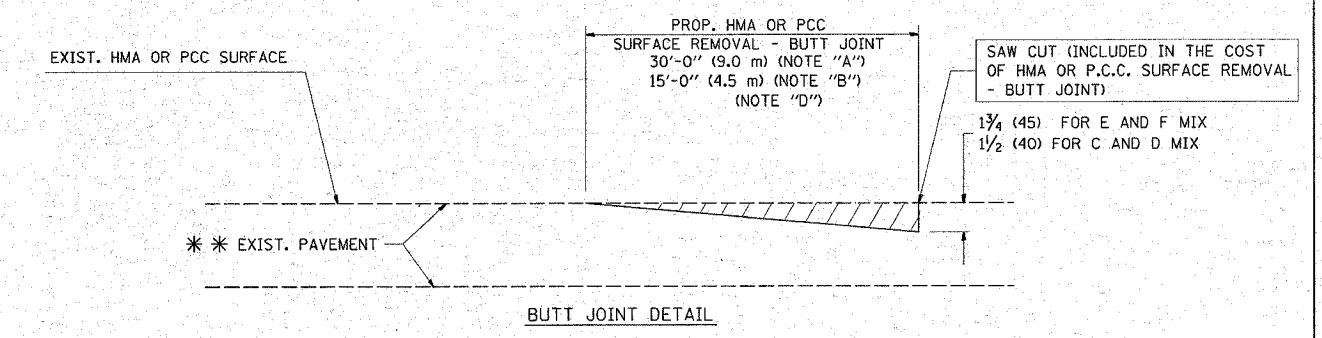

BUTT JOINT DETAIL

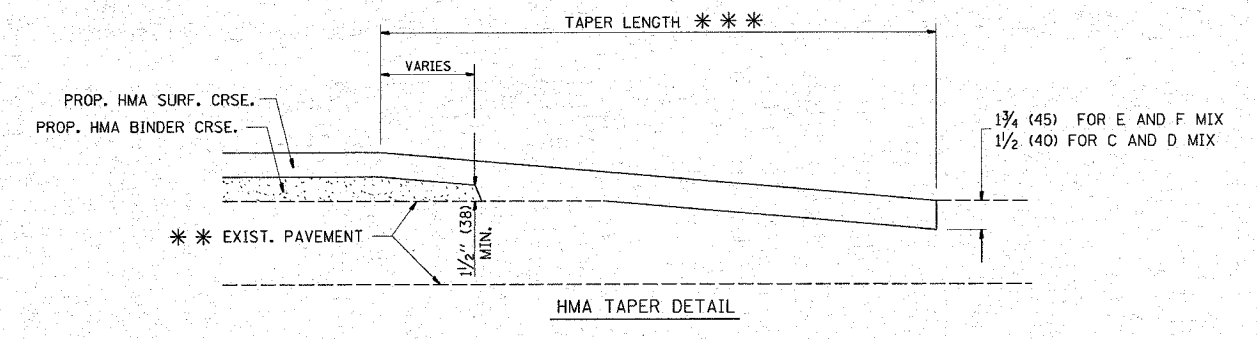

TYPICAL BUTT JOINT AND HMA TAPER FOR RESURFACING ONLY

*** PC CONCRETE, HMA OR HMA RESURFACED PAVEMENT.

NOTES

- A: MAINLINE ROADWAYS AND MAJOR SIDE ROADS.
 - B: MINOR SIDE ROADS.
 - C: THE TEMP. RAMP SHALL BE CONSTRUCTED IMMEDIATELY UPON REMOVAL OF THE EXISTING HMA SURFACE.
 - D: THE BUTT JOINT SHALL BE CONSTRUCTED IMMEDIATELY PRIOR TO PLACING THE PROPOSED HMA COURSES.
 - E: TAPER THE TEMP. RAMP AT A RATE OF 3'-0" (900 mm) PER 1 INCH (25 mm) OF MILLING THICKNESS.
 - F: INSTALLATION AND REMOVAL OF THE 4'-6" (1.35 m) TEMP. RAMP IS INCLUDED IN COST OF HMA SURFACE REMOVAL - BUTT JOINT
 - G: SEE ARTICLE 406.08 AND 406.14 OF THE STANDARD SPECIFICATIONS FOR "HMA AND/OR PCC SURFACE REMOVAL, BUTT JOINT".
- * SEE TYPICAL SECTIONS FOR MILLING THICKNESS.
- *** 20'-0" (6.1 m) PER 1 (25) RESURFACING (NOTE "A")
10'-0" (3.0 m) PER 1 (25) RESURFACING (NOTE "B")

ALL DIMENSIONS ARE IN INCHES (MILLIMETERS) UNLESS OTHERWISE SHOWN.

BASIS OF PAYMENT:

THE BUTT JOINT WILL BE PAID FOR AT THE CONTRACT UNIT PRICE PER SQUARE YARD (SQUARE METER) FOR "HOT-MIX ASPHALT SURFACE REMOVAL - BUTT JOINT" OR FOR "PORTLAND CEMENT CONCRETE SURFACE REMOVAL - BUTT JOINT".

REVISIONS	
NAME	DATE
M. DE YONG	6-13-90
M. DE YONG	7-3-90
M. DE YONG	3-27-92
R. SHAH	09/09/94
R. SHAH	10/25/94
A. ABBAS	03/21/97
M. GOMEZ	04/06/01
R. BORO	01/01/07

ILLINOIS DEPARTMENT OF TRANSPORTATION

BUTT JOINT AND HMA TAPER DETAILS

SCALE: VERT. NONE
HORIZ.

DRAWN BY
CHECKED BY

BD400-05 (VI=BD32)

PLOT DATE = 04/23/08
 FILE NAME = \\s11\pub\p2\user\gpb\work\bd32.dgn
 PLOT SCALE = 50.00000 / 1 IN.
 USER NAME = gpb\gpb

F.A.U. RTE.	SECTION	COUNTY	TOTAL SHEETS	SHEET NO.
1321	(31&72)RS-8	DUPAGE	37	31
STA.		TO STA.		
FED. ROAD DIST. NO.	ILLINOIS	FED. AID PROJECT		
CONTRACT NO. 62703				

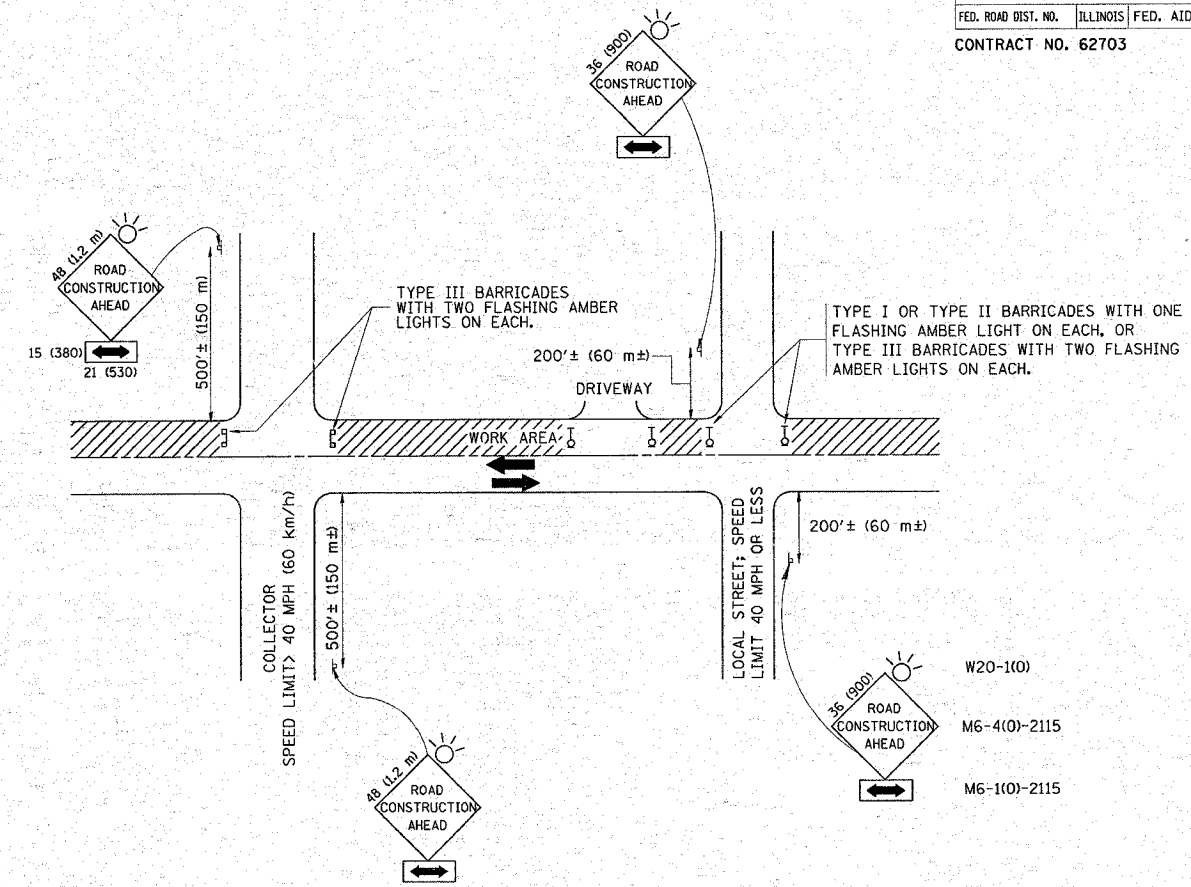

TRAFFIC CONTROL AND PROTECTION FOR SIDE ROADS, INTERSECTIONS, AND DRIVEWAYS

NOTES:

- A. FOR NO LANE RESTRICTION ON THE SIDE ROAD OR DRIVEWAYS
- SIDE ROAD WITH A SPEED LIMIT OF 40 MPH (60 km/h) OR LESS AS SHOWN ON THE DRAWING AND AS DIRECTED BY THE ENGINEER:
 - ONE **ROAD CONSTRUCTION AHEAD** SIGN 36 x 36 (900x900) WITH A FLASHER AND FLAG MOUNTED ON IT APPROXIMATELY 200' (60 m) IN ADVANCE OF THE MAIN ROUTE.
 - THE CLOSED PORTION OF THE MAIN ROUTE SHALL BE PROTECTED BY BLOCKING WITH TYPE I, TYPE II OR TYPE III BARRICADES, 1/3 OF THE CROSS SECTION OF THE CLOSED PORTION.
 - SIDE ROAD WITH A SPEED LIMIT GREATER THAN 40 MPH (60 km/h) AS SHOWN ON THE DRAWING AND AS DIRECTED BY THE ENGINEER:
 - ONE **ROAD CONSTRUCTION AHEAD** SIGN 48 x 48 (1.2 m x 1.2 m) WITH A FLASHER MOUNTED ON IT APPROXIMATELY 500' (150 m) IN ADVANCE OF THE MAIN ROUTE.
 - THE CLOSED PORTION OF THE MAIN ROUTE SHALL BE PROTECTED BY BLOCKING WITH TYPE III BARRICADES, 1/2 OF THE CROSS SECTION OF THE CLOSED PORTION.
3. WHEN THE SIDE ROAD LIES BETWEEN THE BEGINNING OF THE MAINLINE SIGNING AND THE WORK ZONE, A SINGLE HEADED ARROW (M6-1) SHALL BE USED IN LIEU OF THE DOUBLE HEADED ARROW (M6-4).
- B. FOR A LANE CLOSURE ON A SIDE ROAD OR DRIVEWAY:
- USE APPLICABLE PORTIONS OF THE TYPICAL APPLICATION OF TRAFFIC CONTROL DEVICES (STD. 701501, STD. 701606 OR THE APPROPRIATE STANDARD). THE SPACING OF SIGNS AND BARRICADES SHALL BE ADJUSTED FOR FIELD CONDITIONS AS DIRECTED BY THE ENGINEER. THE DIRECTIONAL ARROW SHALL BE COVERED OR REMOVED WHEN NO LONGER CONSISTENT WITH THE SIDE ROAD LANE CLOSURE.
- C. ADVANCE WARNING SIGNS ARE TO BE OMITTED ON DRIVEWAY UNLESS OTHERWISE NOTED.
- D. THE TRAFFIC CONTROL AND PROTECTION FOR SIDE ROADS, INTERSECTIONS, AND DRIVEWAYS SHALL BE INCIDENTAL TO THE COST OF SPECIFIED TRAFFIC CONTROL STANDARDS OR ITEMS.

All dimensions are in millimeters (inches) unless otherwise shown.

REVISIONS	
NAME	DATE
LHA	6/89
T. RAMMACHER	09/08/94
J. OBERLE	10/18/95
A. HOUSEH	03/06/96
A. HOUSEH	10/15/96
T. RAMMACHER	01/06/00

ILLINOIS DEPARTMENT OF TRANSPORTATION
**TRAFFIC CONTROL AND PROTECTION
 FOR
 SIDE ROADS, INTERSECTIONS, AND
 DRIVEWAYS**

SCALE: NONE
 DRAWN BY
 CHECKED BY
 TC-10

PLT DATE = 8/1/2008
 FILE NAME = \\nas1n1r1\p2\user\vg\lbarb\desktop\tbl\tdgn
 PLOT SCALE = 80.0000 / IN.
 USER NAME = gelbarb

F.A.U. RTE.	SECTION	COUNTY	TOTAL SHEETS	SHEET NO.
1321	(31&72SIRS-8	DUPAGE	37	32
STA.		TO STA.		
FED. ROAD DIST. NO.	ILLINOIS	FED. AID PROJECT		
CONTRACT NO. 62703				

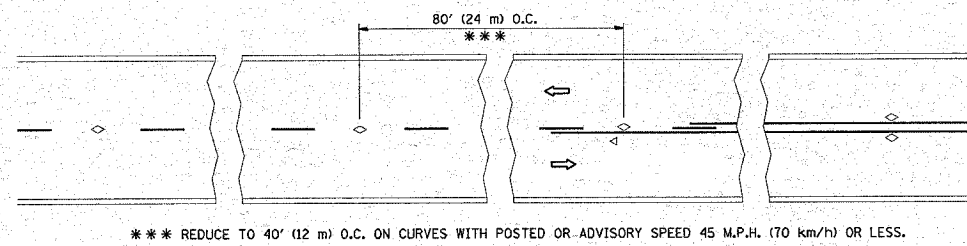

TWO-LANE/TWO-WAY

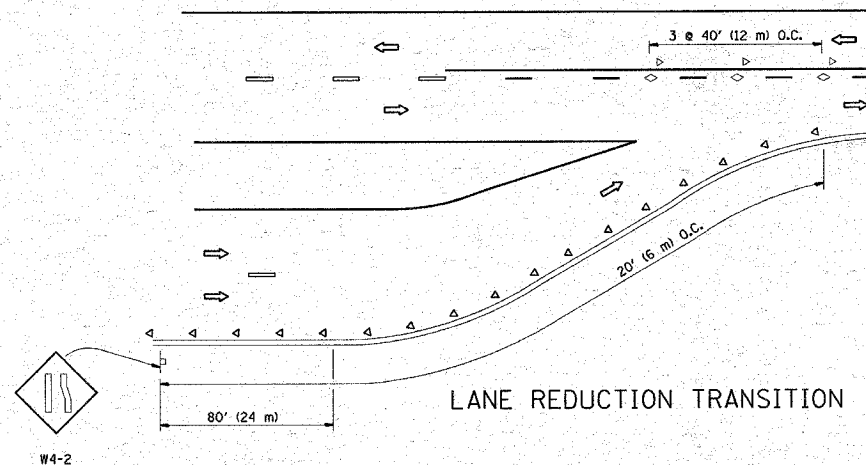

LANE REDUCTION TRANSITION

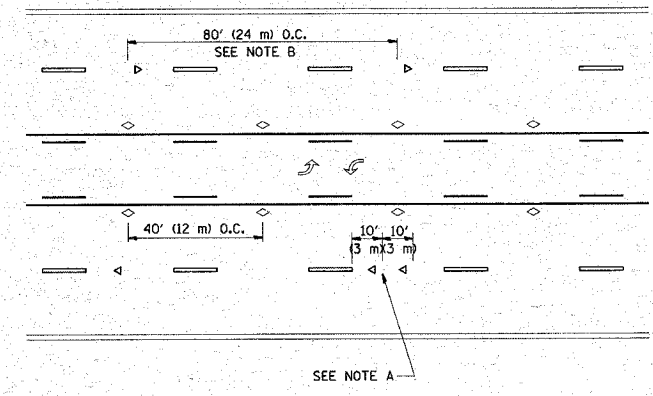

TWO-WAY LEFT TURN

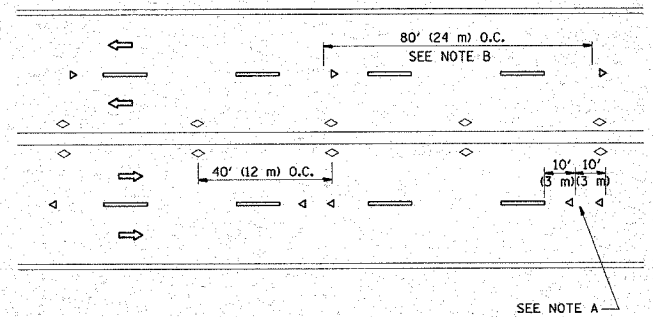

MULTI-LANE/UNDIVIDED

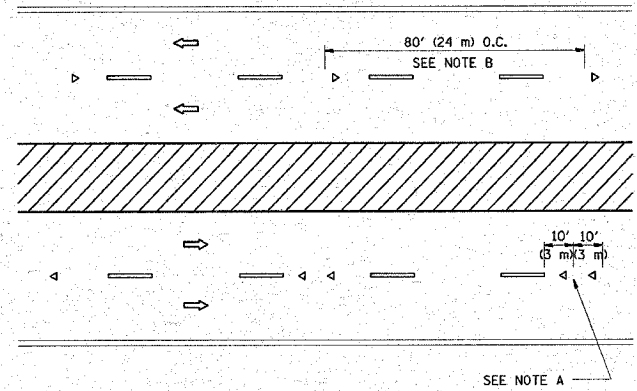

MULTI-LANE/DIVIDED

GENERAL NOTES

1. MARKERS USED WITH DASHED LINES SHALL BE CENTERED IN THE GAP BETWEEN SEGMENTS.
2. MARKERS USED ADJACENT TO SOLID LINES SHALL BE OFFSET 2 TO 3 (50 TO 75) TOWARD TRAFFIC AS SHOWN.
3. MARKERS THROUGH TANGENTS LESS THAN 500' (150 m) IN LENGTH BETWEEN CURVES SHALL BE INSTALLED AT THE LESSER OF THE TWO CURVE SPACINGS.

SYMBOLS

- YELLOW STRIPE
- WHITE STRIPE
- ◁ ONE-WAY AMBER MARKER
- ◁ ONE-WAY CRYSTAL MARKER (W/O)
- ◇ TWO-WAY AMBER MARKER

LANE MARKER NOTES

- A. USE DOUBLE LANE LINE MARKERS SPACED AS SHOWN.
- B. REDUCE TO 40' (12 m) O.C. ON CURVES WHERE ADVISORY SPEEDS ARE 10 M.P.H (20 km/h) LOWER THAN POSTED SPEEDS.

DESIGN NOTES

1. DOUBLE LANE LINE MARKERS SHALL BE USED UNLESS SPECIFIED OTHERWISE.
2. EXCEPT AS SHOWN ON THE LANE REDUCTION TRANSITION AND FREEWAY EXIT RAMP DETAIL, MARKERS ARE NOT TO BE SPECIFIED ON RIGHT EDGE LINES.
3. THE EXACT MARKER LIMITS, SPACING, AND COLOR SHOULD BE INCLUDED IN THE PLANS.
4. MARKERS SHOULD NOT BE USED ALONGSIDE CURBS EXCEPT FOR EXTREMELY SHORT SECTIONS OF CURBS WHERE NOT MORE THAN TWO MARKERS WOULD BE INVOLVED.

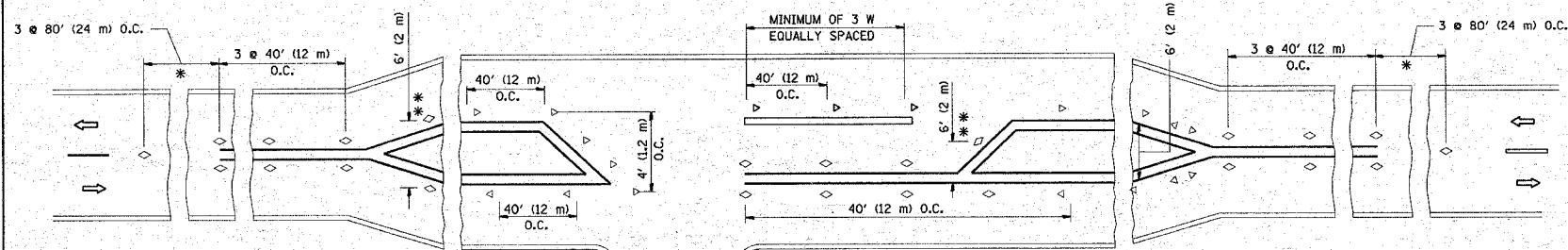

LEFT TURN

- * SEE TWO-LANE/TWO-WAY WHERE MARKERS CONTINUE
- ** WHERE THE MEDIAN WIDTH IS 6' (2 m) OR LESS USE TWO-WAY MARKERS.

All dimensions are in inches (millimeters) unless otherwise shown.

REVISIONS	
NAME	DATE
T. RAMMACHER	09-19-94
T. RAMMACHER	03-12-99
T. RAMMACHER	01-06-00

ILLINOIS DEPARTMENT OF TRANSPORTATION
TYPICAL APPLICATIONS
RAISED REFLECTIVE PAVEMENT
MARKERS (SNOW-PLow RESISTANT)

SCALE: NONE
DRAWN BY CADD
CHECKED BY
TC-11

PLOT DATE = 2/4/2000
 FILE NAME = \\distr\ref2\users\galbarr\desktop\1011.dgn
 PLOT SCALE = 800/800 / IN.
 USER NAME = galbarr

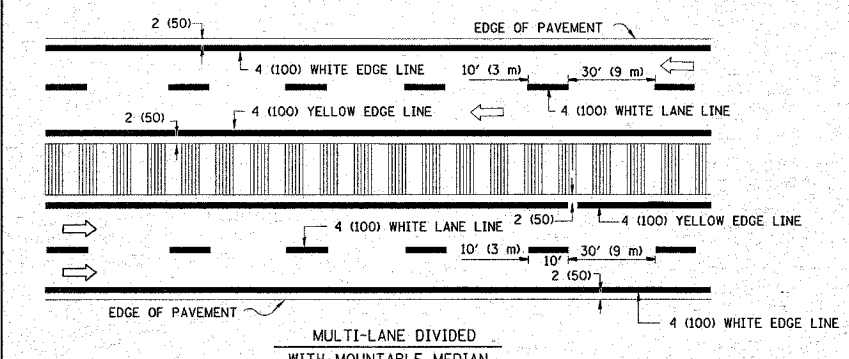
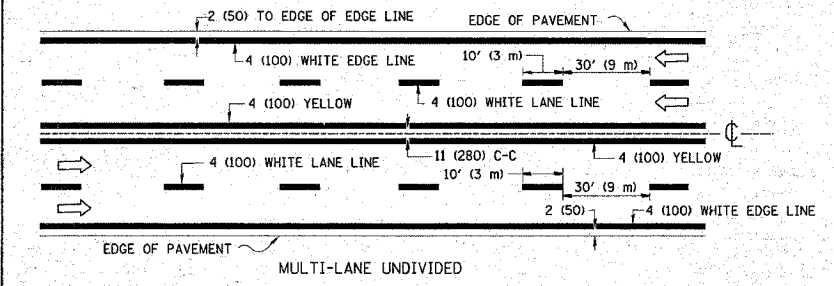
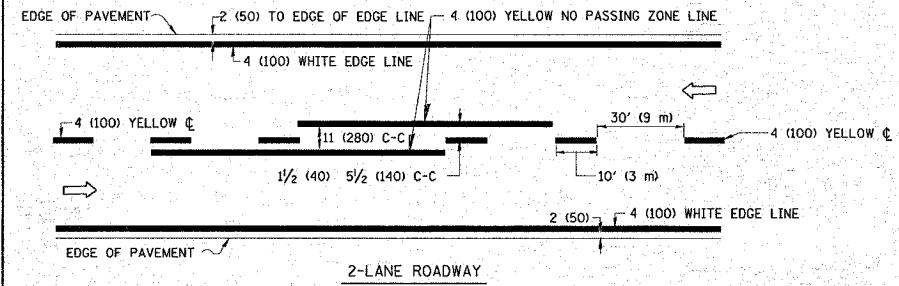

NOTE: MEDIANS WITH BARRIER CURB DO NOT REQUIRE AN EDGE LINE

TYPICAL LANE AND EDGE LINE MARKING

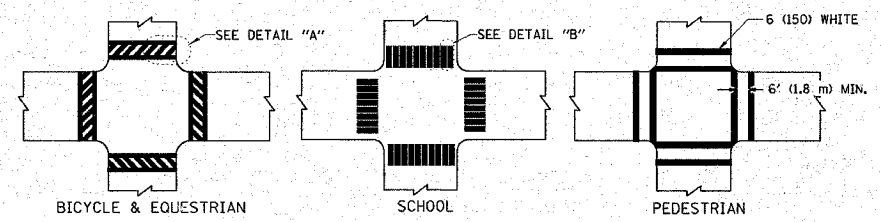

TYPICAL CROSSWALK MARKING

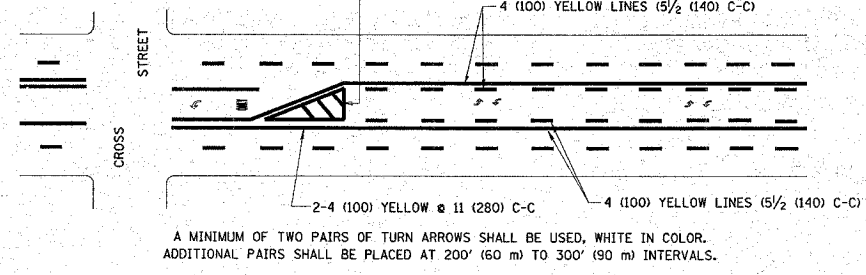
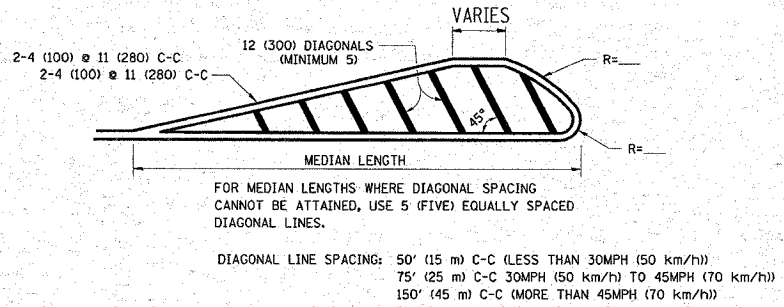
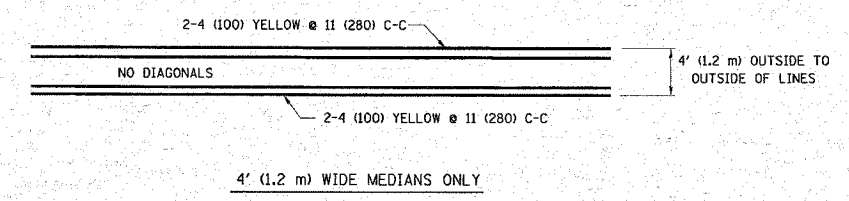

TYPICAL PAINTED MEDIAN MARKING

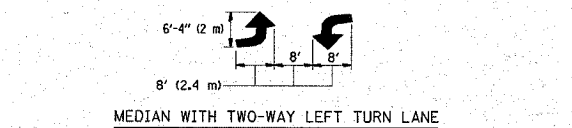

TYPICAL LEFT (OR RIGHT) TURN LANE

FULL SIZE LETTERS 8" (2.4 m) AND ARROWS SHALL BE USED.
 AREA = 15.6 SQ. FT. (1.5 m²) ONLY AREA = 20.8 SQ. FT. (1.9 m²)
 * TURN LANES IN EXCESS OF 400' (120 m) IN LENGTH MAY HAVE AN ADDITIONAL SET OF ARROW - "ONLY" INSTALLED MIDWAY BETWEEN THE OTHER TWO SETS OF ARROW - "ONLY".

TYPICAL TURN LANE MARKING

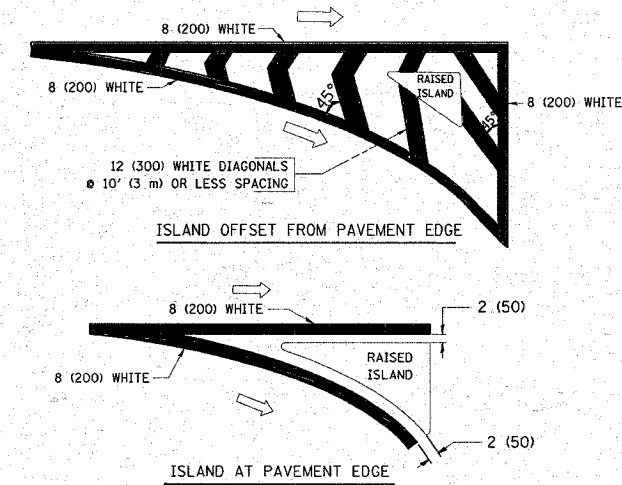

TYPICAL ISLAND MARKING

TYPE OF MARKING	WIDTH OF LINE	PATTERN	COLOR	SPACING / REMARKS
CENTERLINE ON 2 LANE PAVEMENT	4 (100)	SKIP-DASH	YELLOW	10' (3 m) LINE WITH 30' (9 m) SPACE
CENTERLINE ON MULTI-LANE UNDIVIDED PAVEMENT	2 @ 4 (100)	SOLID	YELLOW	11 (280) C-C
NO PASSING ZONE LINES: FOR ONE DIRECTION FOR BOTH DIRECTIONS	4 (100) 2 @ 4 (100)	SOLID SOLID	YELLOW YELLOW	5/2 (140) C-C FROM SKIP-DASH CENTERLINE 11 (280) C-C OMIT SKIP-DASH CENTERLINE BETWEEN
LANE LINES	4 (100) 5 (125) ON FREEWAYS	SKIP-DASH SKIP-DASH	WHITE WHITE	10' (3 m) LINE WITH 30' (9 m) SPACE
DOTTED LINES (EXTENSIONS OF CENTER, LANE OR TURN LANE MARKINGS)	SAME AS LINE BEING EXTENDED	SKIP-DASH	SAME AS LINE BEING EXTENDED	2' (600) LINE WITH 6' (1.8 m) SPACE
EDGE LINES	4 (100)	SOLID	YELLOW-LEFT WHITE-RIGHT	OUTLINE MOUNTABLE MEDIANS IN YELLOW; EDGE LINES ARE NOT USED NEXT TO BARRIER CURB
TURN LANE MARKINGS	6 (150) LINE; FULL SIZE LETTERS & SYMBOLS (8" (2.4m))	SOLID	WHITE	SEE TYPICAL TURN LANE MARKING DETAIL
TWO WAY LEFT TURN MARKING	2 @ 4 (100) EACH DIRECTION 8' (2.4m) LEFT ARROW	SKIP-DASH AND SOLID IN PAIRS	YELLOW WHITE	10' (3 m) LINE WITH 30' (9 m) SPACE FOR SKIP-DASH; 5/2 (140) C-C BETWEEN SOLID LINE AND SKIP-DASH LINE SEE TYPICAL TWO-WAY LEFT TURN MARKING DETAIL
CROSSWALK LINES (PEDESTRIAN) A. DIAGONALS (BIKE & EQUESTRIAN) B. LONGITUDINAL BARS (SCHOOL)	2 @ 6 (150) 12 (300) @ 45° 12 (300) @ 90°	SOLID SOLID SOLID	WHITE WHITE WHITE	NOT LESS THAN 6' (1.8 m) APART 2' (600) APART 2' (600) APART SEE TYPICAL CROSSWALK MARKING DETAILS.
STOP LINES	24 (600)	SOLID	WHITE	PLACE 4' (1.2 m) IN ADVANCE OF AND PARALLEL TO CROSSWALK, IF PRESENT, OTHERWISE, PLACE AT DESIRED STOPPING POINT. PARALLEL TO CROSSROAD CENTERLINE, WHERE POSSIBLE
PAINTED MEDIANS	2 @ 4 (100) WITH 12 (300) DIAGONALS @ 45° NO DIAGONALS USED FOR 4' (1.2 m) WIDE MEDIANS	SOLID	YELLOW: TWO WAY TRAFFIC WHITE: ONE WAY TRAFFIC	11 (280) C-C FOR THE DOUBLE LINE SEE TYPICAL PAINTED MEDIAN MARKING.
GORE MARKING AND CHANNELIZING LINES	8 (200) WITH 12 (300) DIAGONALS @ 45°	SOLID	WHITE	DIAGONALS: 15' (4.5 m) C-C (LESS THAN 30MPH (50 km/h)) 20' (6 m) C-C 30MPH (50 km/h) TO 45MPH (70 km/h) 30' (9 m) C-C (OVER 45MPH (70 km/h))
RAILROAD CROSSING	24 (600) TRANSVERSE LINES; "RR" IS 6' (1.8 m) LETTERS; 16 (400) LINE FOR "X"	SOLID	WHITE	SEE STATE STANDARD 780001 AREA OF: "R"=3.6 SQ. FT. (0.33 m ²) EACH "X"=54.0 SQ. FT. (5.0 m ²)
SHOULDER DIAGONALS	12 (300) @ 45°	SOLID	WHITE - RIGHT YELLOW - LEFT	50' (15 m) C-C (LESS THAN 30MPH (50 km/h)) 75' (25 m) C-C 30 MPH (50 km/h) TO 45MPH (70 km/h) 150' (45 m) C-C (OVER 45MPH (70 km/h))

FOR FURTHER DETAILS ON PAVEMENT MARKING REFER TO STANDARD SPECIFICATIONS FOR ROAD AND BRIDGE CONSTRUCTION AND STATE STANDARD 780001.

All dimensions are in inches (millimeters) unless otherwise shown.

REVISIONS	
NAME	DATE
EVERS	03-19-90
T. RAMMACHER	10-27-94
ALEX HOUSEH	10-09-96
ALEX HOUSEH	10-17-96
T. RAMMACHER	01-06-00

ILLINOIS DEPARTMENT OF TRANSPORTATION
 DISTRICT ONE
 TYPICAL PAVEMENT MARKINGS

SCALE: NONE
 DRAWN BY CADD
 CHECKED BY
 TC-13



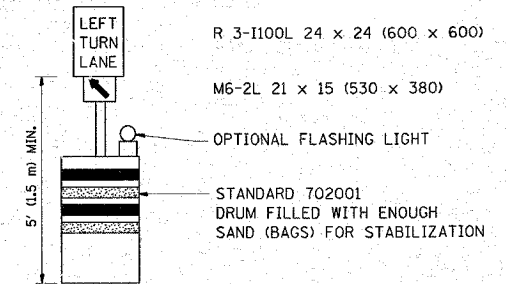
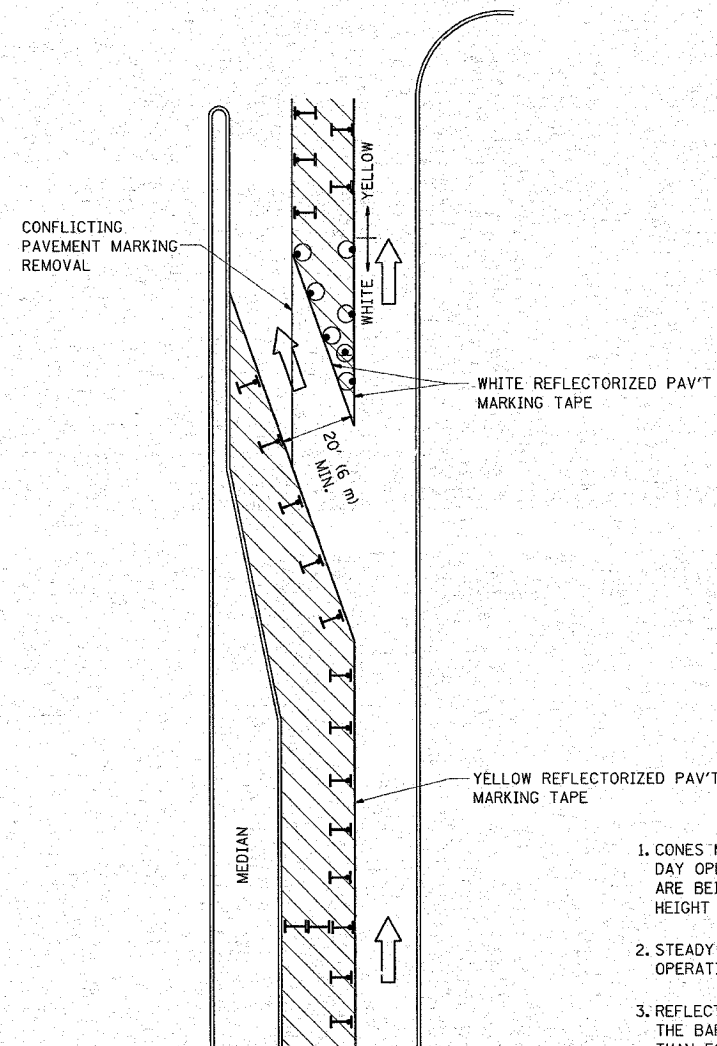



F.A.U. RTE.	SECTION	COUNTY	TOTAL SHEETS	SHEET NO.
1321	(31&72SIRS-8	DUPAGE	37	34
STA.	TO STA.			
FED. ROAD DIST. NO.	ILLINOIS	FED. AID PROJECT		
CONTRACT NO. 62703				

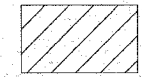

GENERAL NOTES

1. CONES MAY BE SUBSTITUTED FOR BARRICADES OR DRUMS AT HALF THE SPACING DURING DAY OPERATIONS. CONES SHALL BE A MINIMUM OF 28 (710) IN HEIGHT. WHEN CONES ARE BEING USED, THE "LEFT TURN LANE" SIGN MAY BE SKID MOUNTED AT A MINIMUM HEIGHT OF 5' (1.5 m).
2. STEADY BURNING LIGHTS WILL NOT BE REQUIRED ON BARRICADES OR DRUMS FOR DAY OPERATIONS. ALL LIGHTS SHALL BE MONODIRECTIONAL.
3. REFLECTORIZED TEMPORARY PAVEMENT MARKING TAPE SHALL BE PLACED THROUGHOUT THE BARRICADED AREA OF EACH TURN BAY WHERE THE CLOSURE TIME IS GREATER THAN FOURTEEN DAYS.
4. THIS APPLICATION ALSO APPLIES WHEN WORK IS BEING PERFORMED IN THE RIGHT LANE(S) AND THE RIGHT TURN BAY IS TO REMAIN OPEN. UNDER THIS CONDITION, "RIGHT TURN LANE" R3-100 24 x 24 (600 x 600) AND M6-2R 21 x 15 (530 x 380) SHALL BE USED.
5. THESE CONTROLS SHALL SUPPLEMENT MAINLINE TRAFFIC CONTROL FOR LANE CLOSURES.
6. LONGITUDINAL DIMENSIONS MAY BE ADJUSTED TO FIT FIELD CONDITIONS.
7. FORM BT 725 IS REQUIRED.
8. TRAFFIC CONTROL AND PROTECTION AT TURN BAYS (TO REMAIN OPEN TO TRAFFIC) SHALL BE INCLUDED IN THE COST SPECIFIED TRAFFIC CONTROL STANDARDS OR ITEMS.

LEGEND

-  WORK AREA
-  LANE OPEN TO TRAFFIC
-  TYPE I OR II BARRICADE WITH STEADY BURN LIGHT
-  DRUM WITH STEADY BURN LIGHT
-  DRUM WITH SIGN (WITH OPTIONAL FLASHING LIGHT) SEE DETAIL
-  TYPE I OR II CHECK BARRICADE WITH FLASHING LIGHT

All dimensions are in Inches (millimeters) unless otherwise shown.

REVISIONS	
NAME	DATE
T. RAMMACHER	09/08/94
A. HOUSEH	11/07/95
A. HOUSEH	10/12/96
T. RAMMACHER	01/06/00

ILLINOIS DEPARTMENT OF TRANSPORTATION
**TRAFFIC CONTROL AND PROTECTION
 AT TURN BAYS
 (TO REMAIN OPEN TO TRAFFIC)**

SCALE: NONE

DRAWN BY
 CHECKED BY LHA

TC-14

PLOT DATE = 3/1/2008
 FILE NAME = \\netstf2\user\galbamba\Desktop\to14.dgn
 PLOT SCALE = 50.0000 / 1"
 USER NAME = galbamba

F.A.U. RTE.	SECTION	COUNTY	TOTAL SHEETS	SHEET NO.
1321	(31&72S)RS-8	DUPAGE	37	35
STA.		TO STA.		
FED. ROAD DIST. NO.		ILLINOIS FED. AID PROJECT		
CONTRACT NO. 62703				

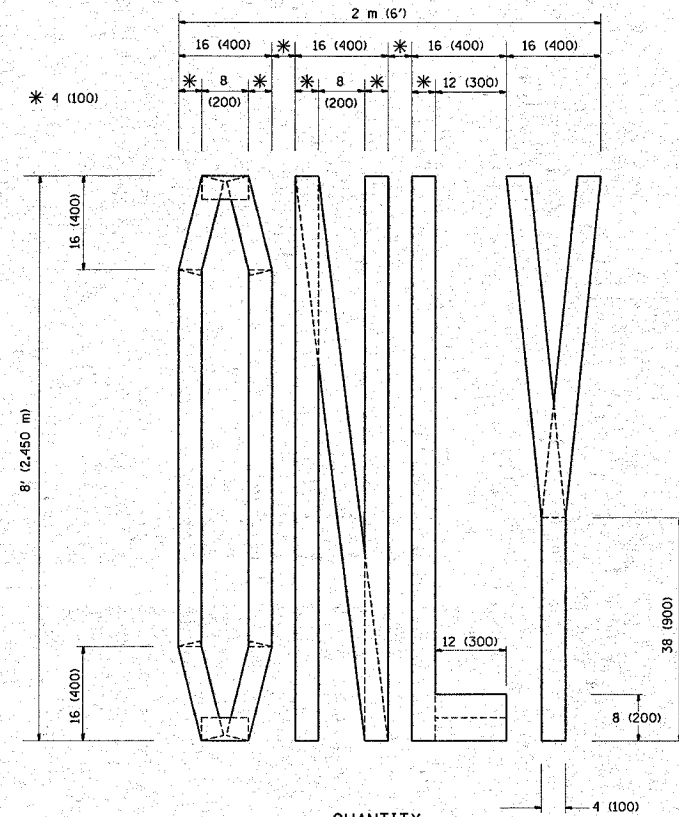

QUANTITY
 4 (100) LINE = 64.1 ft. (19.7 m)
 21.1 sq. ft. (1.97 sq. m)

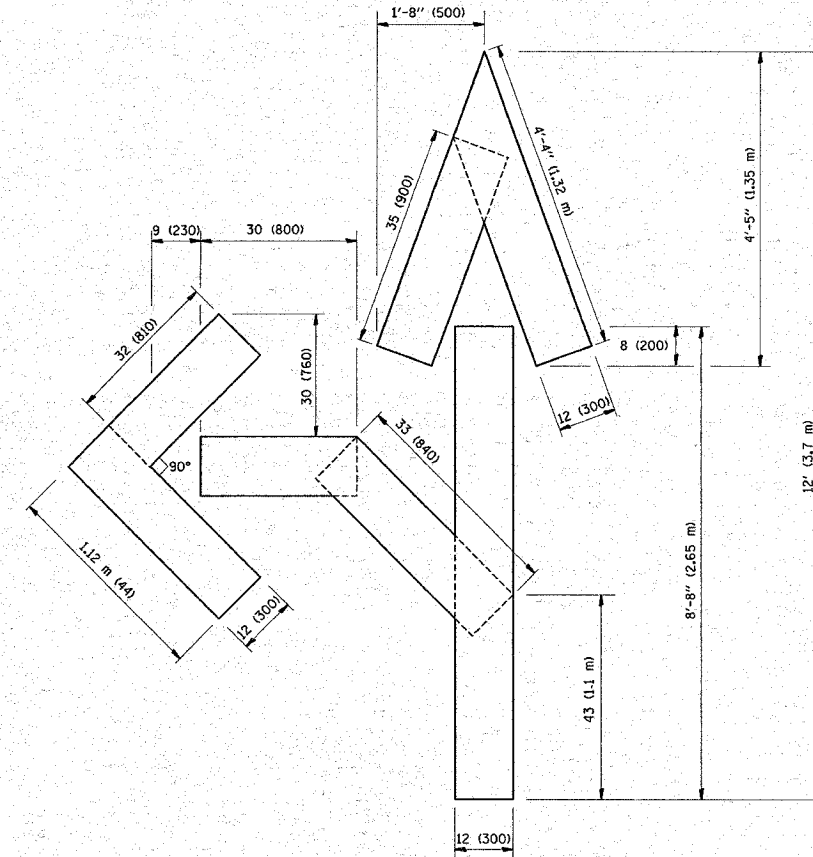

QUANTITY
 4 (100) LINE = 82.5 ft. (25.3 m)
 27.5 sq. ft. (2.53 sq. m)

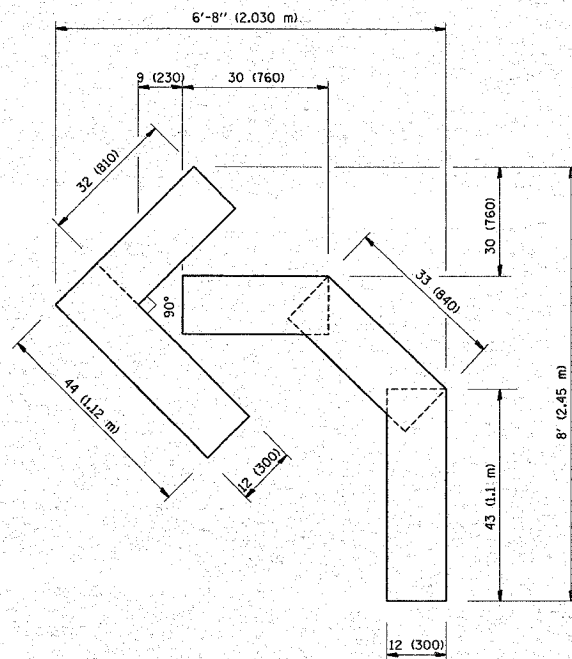

QUANTITY
 4 (100) LINE = 45.5 ft. (13.9 m)
 15.2 sq. ft. (1.39 sq. m)

All dimensions are in inches (millimeters) unless otherwise shown.

REVISIONS	
NAME	DATE
T. RAMMACHER	09/18/94
J. OBERLE	06/01/96
T. RAMMACHER	06/05/96
T. RAMMACHER	11/04/97
T. RAMMACHER	03/02/98
E. GOMEZ	08/28/00

ILLINOIS DEPARTMENT OF TRANSPORTATION

PAVEMENT MARKING
 LETTERS AND SYMBOLS
 FOR TRAFFIC STAGING

SCALE: NONE

DRAWN BY CADD

CHECKED BY

TC-16

F.A.U. RTE.	SECTION	COUNTY	TOTAL SHEETS	SHEET NO.
1321	(31&72)RS-B	DUPAGE	37	36
STA.		TO STA.		
FED. ROAD DIST. NO.		ILLINOIS FED. AID PROJECT		

CONTRACT NO. 62703

LOOPS NEXT TO SHOULDERS

PROVIDE A PAVEMENT REPLACEMENT NOTE WHICH SHOULD EQUAL 3' (900 mm) X WIDTH OF PAVED SHOULDER.

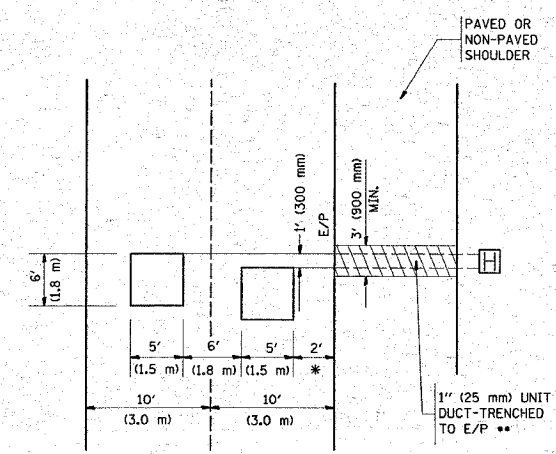

* = (600 mm)
 ** UNIT DUCT IS TO BE SHOWN ON PLAN SHEETS BUT SHALL NOT BE INCLUDED IN THE PAY ITEMS.

**LEFT TURN LANES WITH MEDIANS
 VOLUME DENSITY ("FAR OUT" DETECTION)
 ON SAME APPROACH
 (PROTECTED / PERMITTED LEFT TURN PHASING)**

HANDHOLE LOCATION MAY VARY DEPENDING ON GEOMETRICS AND DESIGN OF TRAFFIC SIGNALS. HEAVY-DUTY HANDHOLES TO BE USED WHEN THE MEDIAN IS MOUNTABLE. REFER TO STANDARD 814001 TO ENSURE THAT HANDHOLE FITS IN MEDIAN.

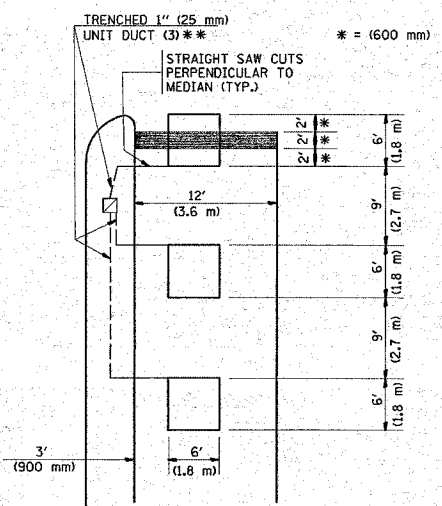

* = (600 mm)
 ** UNIT DUCT IS TO BE SHOWN ON PLAN SHEETS BUT SHALL NOT BE INCLUDED IN THE PAY ITEMS.
 NOTE: DUAL LEFT TURNS NOT SHOWN REFER TO PLAN SHEET FOR DETECTOR LOOP REPLACEMENT.

**LEFT TURN LANES WITHOUT MEDIANS
 VOLUME DENSITY ("FAR OUT" DETECTION)
 ON SAME APPROACH
 (PROTECTED / PERMITTED LEFT TURN PHASING)**

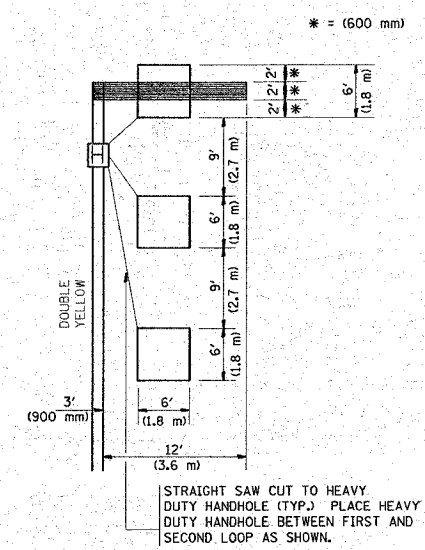

NOTE: DUAL LEFT TURNS NOT SHOWN REFER TO PLAN SHEET FOR DETECTOR LOOP REPLACEMENT

NOTES:

- VEHICLES LOOP DETECTORS**
- * ALL LEAD IN CABLE SHALL BE TWO CONDUCTOR NO. 14 TWISTED, SHIELDED.
 - * EACH DETECTOR LOOP SHALL HAVE ITS OWN SAW CUT FROM THE LOOP TO THE EDGE OF PAVEMENT OR TO A HANDHOLE IN THE PAVEMENT.
 - * EACH DETECTOR LOOP SHALL HAVE ITS OWN ONE INCH (25 mm) UNIT DUCT BETWEEN THE EDGE OF PAVEMENT AND THE FIRST HANDHOLE OR JUNCTION BOX. EACH UNIT DUCT RUN SHALL BE SHOWN ON THE PLANS BY THE DESIGNER, BUT SHALL NOT BE PAID FOR SEPARATELY. THIS ITEM IS INCIDENTAL TO THE PAY ITEM FOR DETECTOR LOOPS.
 - * ONE DIMENSION OF ALL DETECTOR LOOPS SHALL BE SIX FEET (1.8 m)
 - * EACH LANE OF NON-LOCKING, PRESENCE DETECTION AND EACH LANE OF A DOUBLE LEFT TURN LANE REQUIRES A SEPARATE INDUCTIVE LOOP DETECTOR AND LEAD IN CABLE.
 - * WHEN NON-LOCKING, PRESENCE DETECTION IS USED, MORE THAN ONE LOOP PER LANE IS REQUIRED BEHIND THE STOP BAR (i.e. 1-1/2, 1-3/4, 2).
 - * WHEN SYSTEM LOOPS ARE REQUIRED ON AN APPROACH OF AN INTERSECTION, THE LOOPS USED FOR VOLUME DENSITY AND INTERSECTION TIMING SHALL ALSO BE USED AS SYSTEM DETECTORS. EACH ONE OF THESE TYPE OF LOOPS REQUIRES A SEPARATE TWO CONDUCTOR NO. 14 TWISTED SHIELDED CABLE AND A SEPARATE INDUCTIVE LOOP DETECTOR WHEN NEW CONTROLLERS ARE UTILIZED. THE DESIGNER SHALL LABEL THESE TYPES OF LOOPS AS "INTERSECTION AND SAMPLING (SYSTEM) DETECTORS" ON THE SIGNAL LAYOUT, THE INTERCONNECT PLAN AND THE SYSTEM CABLE PLAN. WHEN AN EXISTING CONTROLLER IS UTILIZED FOR THIS TYPE OF DETECTION, THE PAY ITEM "INDUCTIVE LOOP DETECTOR WITH SYSTEM OUTPUT" SHOULD BE USED.

**ARTERIAL-VOLUME DENSITY ("FAR OUT" DETECTION)
 CROSS STREET-VOLUME DENSITY ("FAR OUT" DETECTION)**

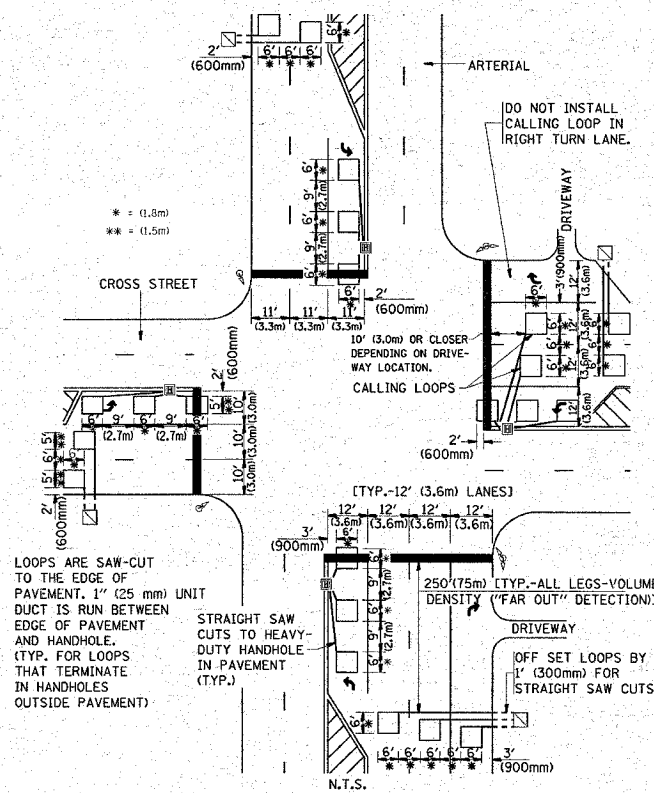

LOOPS ARE SAW-CUT TO THE EDGE OF PAVEMENT. 1" (25 mm) UNIT DUCT IS RUN BETWEEN EDGE OF PAVEMENT AND HANDHOLE. (TYP. FOR LOOPS THAT TERMINATE IN HANDHOLES OUTSIDE PAVEMENT)
 STRAIGHT SAW CUTS TO HEAVY-DUTY HANDHOLE IN PAVEMENT (TYP.)
 OFF SET LOOPS BY 1' (300mm) FOR STRAIGHT SAW CUTS.
 N.T.S.

DETAIL 1
 N.T.S.

**ARTERIAL-VOLUME DENSITY ("FAR OUT" DETECTION)
 CROSS STREET-NON VOLUME DENSITY ("UPTIGHT" PRESENCE DETECTION)**

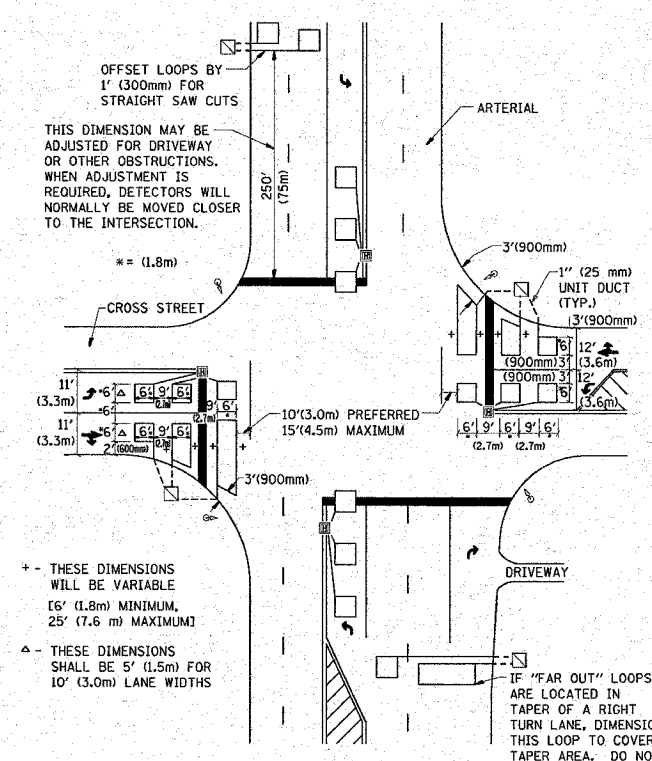

OFFSET LOOPS BY 1' (300mm) FOR STRAIGHT SAW CUTS
 THIS DIMENSION MAY BE ADJUSTED FOR DRIVEWAY OR OTHER OBSTRUCTIONS. WHEN ADJUSTMENT IS REQUIRED, DETECTORS WILL NORMALLY BE MOVED CLOSER TO THE INTERSECTION.
 * = (1.8m)
 ** = (1.5m)
 + - THESE DIMENSIONS WILL BE VARIABLE [6' (1.8m) MINIMUM, 25' (7.6 m) MAXIMUM]
 ^ - THESE DIMENSIONS SHALL BE 5' (1.5m) FOR 10' (3.0m) LANE WIDTHS
 IF "FAR OUT" LOOPS ARE LOCATED IN TAPER OF A RIGHT TURN LANE, DIMENSION THIS LOOP TO COVER TAPER AREA. DO NOT COVER THE LEFT TURN LANE OR LEFT TURN LANE TAPER.

DETAIL 2
 N.T.S.

PLACEMENT OF DETECTORS

THE FOLLOWING FIGURES REPRESENT THE MOST COMMON DETECTOR LOOP LOCATIONS AND SIZES. ADJUSTMENTS WILL BE NECESSARY FOR SPECIFIC GEOMETRIC CONSIDERATIONS.

LOCATIONS AND DEMENSIONS OF DETECTOR LOOPS ARE REQUIRED ON ALL SIGNAL LAYOUT PLAN SHEETS.

"FAR OUT" DETECTION REFERS TO LOCKING, PRESENCE TYPE DETECTION LOCATED IN THRU LANES, RIGHT TURN LANES, AND RIGHT TURN LANE TAPER AREAS (IF APPLICABLE), USUALLY 250' (75 m) IN ADVANCE OF STOP BARS. "UPTIGHT" DETECTION REFERS TO NON-LOCKING PRESENCE TYPE DETECTION LOCATED IN ALL LANES AND 10'-15' (3.0 m-4.5 m) BEHIND THE CROSSING STREET'S EDGE OF PAVEMENT EXTENDED.

NOTE:
 ALL DETAILS AND NOTES SHOWN ARE FROM THE I.D.O.T. DISTRICT 1 TRAFFIC SIGNAL DESIGN GUIDELINES DATED JANUARY 1995

THIS DRAWING HAS BEEN PREPARED TO ASSIST THE RESIDENT ENGINEER FOR ALL ROADWAY RESURFACING OR S.M.A.R.T. PROJECTS WHERE THE DIMENSIONS ARE NOT SHOWN ON THE PLANS AND THE FINAL LOCATIONS FOR CROSSWALKS OR STOP BARS ARE NOT DETERMINED.

REVISIONS	
NAME	DATE

ILLINOIS DEPARTMENT OF TRANSPORTATION
 DISTRICT 1
 DETECTOR LOOP
 INSTALLATION DETAILS
 FOR ROADWAY RESURFACING
 DESIGNED BY
 DRAWN BY CADD
 CHECKED BY R.K.F.
 TS07

DATE = 3/1/2008
 FILE NAME = \\nct\cadd\2\Users\gabernb\work\top\1487.dgn
 PLOT SCALE = 50:0000 / IN.
 USER NAME = gabernb

F.A.U. RTE.	SECTION	COUNTY	TOTAL SHEETS	SHEET NO.
1321	(31&725)RS-8	DUPAGE	37	37
STA.		TO STA.		
FED. ROAD DIST. NO.		ILLINOIS FED. AID PROJECT		
CONTRACT NO. 62703				

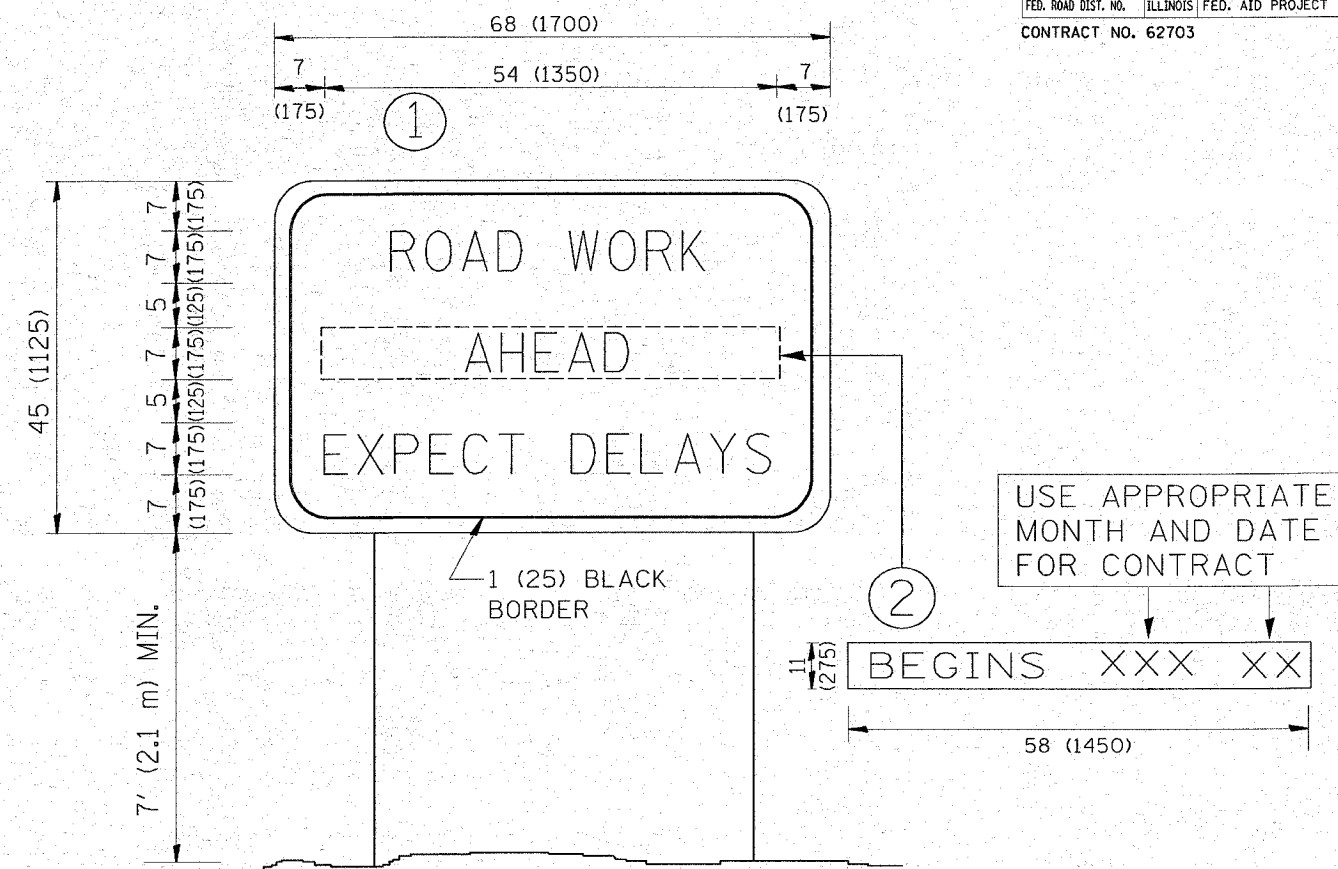

NOTES:

1. USE BLACK LETTERING ON ORANGE BACKGROUND.
2. ERECT SIGNS IN ADVANCE OF THE LOCATION FOR THE "ROAD CONSTRUCTION AHEAD" SIGN AT LOCATIONS AS DIRECTED BY THE ENGINEER.
3. ERECT SIGN ① WITH INSTALLED PANEL ② ONE WEEK PRIOR TO THE START OF CONSTRUCTION.
4. REMOVE PANEL ② SOON AFTER THE START OF CONSTRUCTION.
5. SEE SPECIAL PROVISION FOR "TEMPORARY INFORMATION SIGNING" FOR ADDITIONAL INFORMATION.
6. ONE SIGN ASSEMBLY EQUALS 25.70 SQ. FT. (2.3 SQ. M.)
7. SHALL BE PAID FOR AS TEMPORARY INFORMATION SIGNING.

ALL DIMENSIONS ARE IN INCHES (MILLIMETERS) UNLESS OTHERWISE SHOWN.

REVISIONS		ILLINOIS DEPARTMENT OF TRANSPORTATION
NAME	DATE	
R. MIRS	9-15-97	ARTERIAL ROAD INFORMATION SIGN
R. MIRS	12-11-97	
T. RAMMACHER	2-2-99	
C. JUCIUS	1-31-07	

SCALE: NONE

DRAWN BY DESIGN
CHECKED BY
TC22