

FAU RTE.	SECTION	COUNTY	TOTAL SHEETS	SHEET NO.
2826, 3601	*	COOK	16	1
STA.		TO STA.		
FED. ROAD DIST. NO.		ILLINOIS		
* 07-00071-00-RS				

INDEX OF SHEETS

SHEET NO.	SHEET NAME
1	COVER
2	GENERAL NOTES & LIST OF HIGHWAY STANDARDS
3	SUMMARY OF QUANTITIES
4	TYPICAL CROSS SECTIONS AND DETAILS
5-7	APPLE DRIVE PLANS
8	APPLE TREE DRIVE & LAUREL LANE PLAN
9-13	LAUREL LANE PLANS
14	CURB AND GUTTER REMOVAL AND REPLACEMENT, BD-24, DISTRICT 1
15	BUTT JOINT AND HMA TAPER DETAIL, BD-32, DISTRICT 1
16	DISTRICT ONE, TYPICAL PAVEMENT MARKING, TC-13

**STATE OF ILLINOIS
DEPARTMENT OF TRANSPORTATION
DIVISION OF HIGHWAYS**

**PLANS FOR PROPOSED
FEDERAL AID HIGHWAY**

VILLAGE OF HAZEL CREST

FAU RTE. 2826 (APPLE TREE DRIVE), 175TH STREET TO LAUREL LANE

FAU RTE. 3601 (LAUREL LANE), APPLE TREE DRIVE TO ELM DRIVE

LOCAL AGENCY PAVEMENT PRESERVATION - RESURFACING

COOK COUNTY

SECTION 07-00071-00-RS

PROJECT M-8003 (953)

C-91-195-08



LOCATION OF SECTION INDICATED THIS: - [black rectangle] -

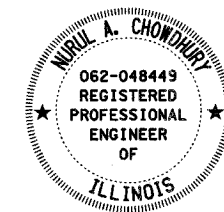

LICENSE EXPIRATION DATE: 11/30/09

TRAFFIC DATA:
ADT=375

SPEED LIMIT ON APPLE TREE DRIVE - 25 MPH
SPEED LIMIT ON LAUREL LANE - 20 MPH

STATE OF ILLINOIS
DEPARTMENT OF TRANSPORTATION
DIVISION OF HIGHWAYS

Approved: *Robert B. Donaldson* 3/25/08 DATE
Village President, Village of Hazel Crest SIGNATURE

Passed: *APRIL 11, 2008* DATE
Christopher Holt SIGNATURE
District #1 Engineer of Local Roads & Streets

Releasing for Bid
Based on Limited
Review: *APRIL 14, 2008* DATE
Diana M. O'Keefe SIGNATURE
Deputy Director of Highways, Region #1 Engineer

PRINTED BY AUTHORITY OF THE STATE OF ILLINOIS

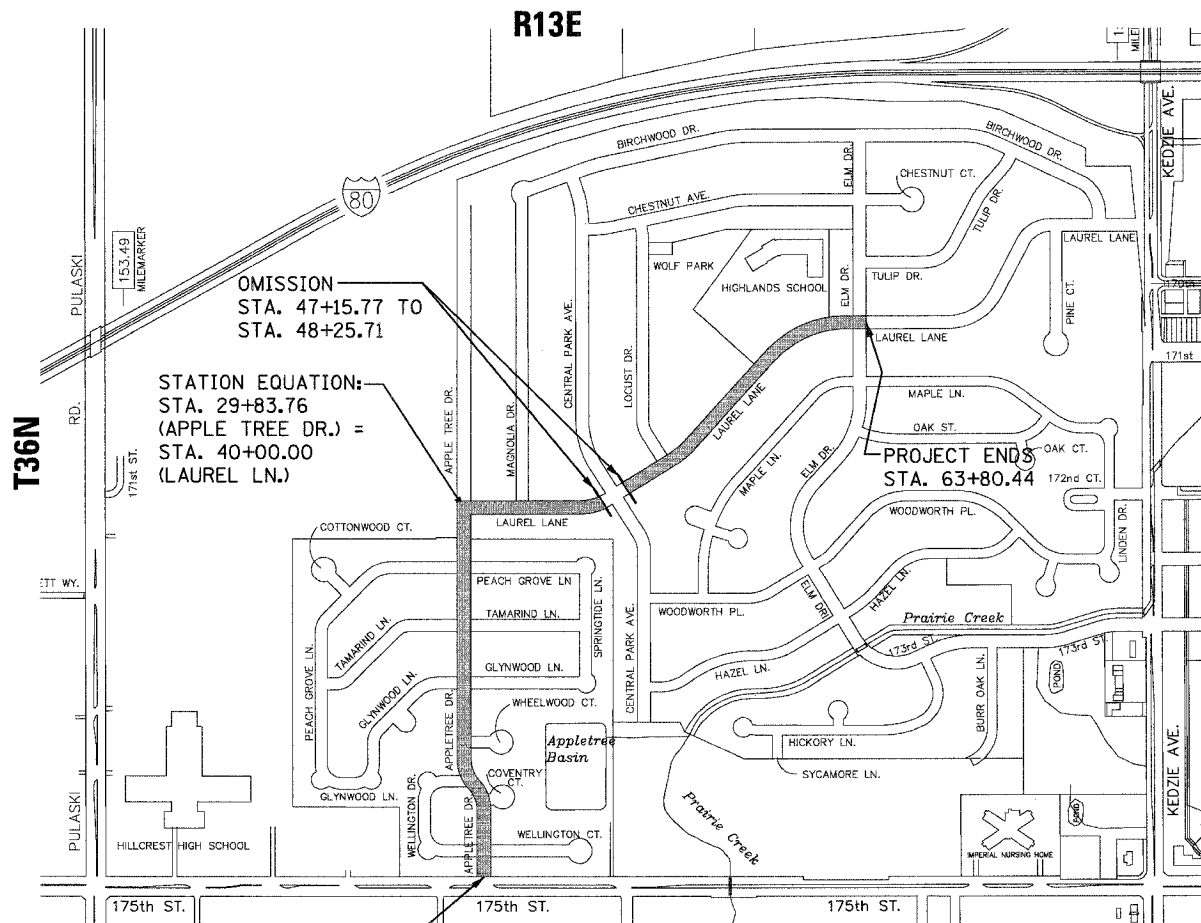

LOCATION MAP

N.T.S.

GROSS LENGTH OF PROJECT = 4,257.00 FT = 0.81 MILE
NET LENGTH OF PROJECT = 4,147.00 FT = 0.79 MILE

PROJECT LOCATED IN
VILLAGE OF HAZEL CREST

DESIGN DESIGNATION:
390(28) COLLECTOR 2.51 (HMA8)

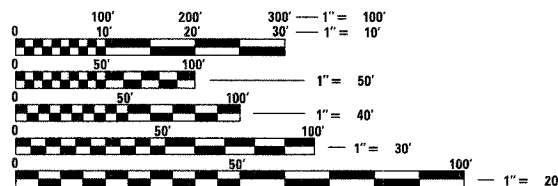

FULL SIZE PLANS HAVE BEEN PREPARED USING STANDARD ENGINEERING SCALES. REDUCED SIZED PLANS WILL NOT CONFORM TO STANDARD SCALES. IN MAKING MEASUREMENTS ON REDUCED PLANS, THE ABOVE SCALES MAY BE USED.

J.U.L.I.E.
JOINT UTILITY LOCATION INFORMATION FOR EXCAVATION
1-800-892-0123

CONTRACT NO. 63019

GLOBETROTTERS ENGINEERING CORP.: CHANDRA S. TRIVEDI (312)697-3580

FIELD ENGINEER : MEL MANGOBA (847) 705-4408

FAU RTE.	SECTION	COUNTY	TOTAL SHEETS	SHEET NO.
285-3501	*	COOK	16	2
STA. N/A		TO STA. N/A		
FED. ROAD DIST. NO.		ILLINOIS		

* 07-00071-00-RS

GENERAL NOTES:

1. THIS PROJECT WILL BE CONSTRUCTED IN ACCORDANCE WITH THE ILLINOIS DEPARTMENT OF TRANSPORTATION "STANDARD SPECIFICATIONS FOR ROAD AND BRIDGE CONSTRUCTION, ADOPTED JANUARY 1, 2007", THE LATEST EDITION OF THE "MANUAL ON UNIFORM TRAFFIC CONTROL DEVICES FOR STREETS AND HIGHWAYS", THE "MANUAL OF TEST PROCEDURES OF MATERIALS" IN EFFECT ON THE DATE OF INVITATION OF BIDS, AND THE "SUPPLEMENTAL SPECIFICATIONS AND RECURRING SPECIAL PROVISIONS" INDICATED ON THE CHECK SHEET INCLUDED IN THE CONTRACT'S SPECIFICATIONS, WHICH APPLY TO AND GOVERN THE CONSTRUCTION OF MFT 07-00071-00-RS.
 2. THE TERM "VILLAGE" IS USED HEREIN IN REFERENCE TO NOTIFICATION(S) BY OR PERMIT(S)/PERMISSION(S) TO BE OBTAINED BY THE CONTRACTOR SHALL MEAN THE MUNICIPAL OFFICIAL DULY DESIGNATED BY THE VILLAGE BOARD FOR THE PURPOSE. THE CONTRACTOR SHALL CONTACT THE VILLAGE MANAGER'S OFFICE AT (708) 335-9600 TO GET THE NAME(S) AND CONTACT INFORMATION OF SUCH DESIGNATED OFFICIALS/STAFF.
 3. A MINIMUM OF TWO (2) WORKING DAYS BEFORE STARTING EXCAVATION, THE CONTRACTOR SHALL CONTACT JULIE (1-800-892-0123) TO HAVE THE LOCATION OF
4. IF AND WHEN EXISTING DRAINAGE FACILITIES ARE DISTURBED BY PROPOSED CONSTRUCTION, THE CONTRACTOR SHALL PROVIDE AND MAINTAIN TEMPORARY OUTLETS AND CONNECTIONS FOR ALL PRIVATE AND PUBLIC DRAINS, SEWERS OR CATCH BASINS, AND PROVIDE ADEQUATE FACILITIES TO TAKE IN ALL STORM WATER INCLUDING PUMPING AND A TEMPORARY OUTLET, IF NECESSARY. THIS WORK SHALL NOT BE PAID FOR DIRECTLY, BUT WILL BE CONSIDERED INCIDENTAL TO THE CONTRACT.
 5. ALL UTILITIES AND THE ASSOCIATED DATA SHOWN ON THE PLANS ARE FROM THE AVAILABLE RECORDS AND REPRESENT THE BEST AVAILABLE INFORMATION. HOWEVER, THEIR ACCURACY OR COMPLETENESS IS NOT GUARANTEED. IT SHALL REMAIN THE CONTRACTOR'S RESPONSIBILITY TO CONTACT JULIE (1-800-892-0123) AND VARIOUS UTILITY FIRMS AND/OR ORGANIZATIONS HAVING FACILITIES AT THE SITE TO DETERMINE THEIR ACTUAL LOCATIONS, AND OTHER DETAILS, AND DETERMINE WHETHER THEY ARE IN CONFLICT WITH THE PROPOSED WORK. THE CONTRACTOR SHALL BRING ALL SUCH CONFLICTS TO THE ENGINEER'S ATTENTION AND SHALL NOT PROCEED WITH THE PORTION OF THE WORK IN CONFLICT UNTIL THE RESOLUTION OF THE CONFLICT(S) AND THE AUTHORIZATION TO PROCEED.
 6. THE CONTRACTOR SHALL BE RESPONSIBLE FOR THE PROTECTION OF ALL EXISTING UNDERGROUND UTILITIES WITHIN THE PROJECT LIMITS, WHETHER OR NOT SUCH UTILITIES ARE SHOWN ON THE PLANS. ANY UTILITY DAMAGED DURING CONSTRUCTION, SHALL BE REPAIRED OR REPLACED TO THE SATISFACTION OF THE RESPECTIVE UTILITY, BY THE CONTRACTOR WITHOUT ANY ADDITIONAL COMPENSATION.
 7. THE CONTRACTOR SHALL MAKE EVERY POSSIBLE EFFORT TO PREVENT CONSTRUCTION DEBRIS FROM ENTERING EXISTING MANHOLES, CATCH BASINS, INLETS OR DRAINAGE DITCHES. ANY SUCH DEBRIS, DETERMINED BY THE VILLAGE TO BE PRESENT IN SUCH STRUCTURES DUE TO THE CONTRACTOR'S OPERATIONS SHALL BE PROMPTLY REMOVED AND DISPOSED OFF BY THE CONTRACTOR TO THE VILLAGE'S SATISFACTION AT NO ADDITIONAL COMPENSATION.
 8. ALL REMOVAL OF CURB AND GUTTER, SIDEWALK, DRIVEWAYS AND PAVEMENT ETC. SHALL BE BY SAWCUTTING TO ENSURE A CLEAN REMOVAL WITHOUT DAMAGING OR GAUGING THE PORTION(S) TO REMAIN. ALL SUCH DAMAGE OR GAUGING SHALL BE REPAIRED BY THE CONTRACTOR TO THE VILLAGE'S SATISFACTION WITHOUT ANY ADDITIONAL COMPESATION. THE SAWCUTTING SHALL NOT BE COMPENSATED FOR SEPARATELY BUT SHALL BE INCLUDED IN THE CONTRACT UNIT PRICE FOR THE REMOVAL OF THE ITEM INVOLVED.
 9. THE CONTRACTOR SHALL MAINTAIN AT ALL TIMES ADEQUATE ACCESS TO ALL PROPERTIES ADJACENT TO THE PROPOSED IMPROVEMENT. THE COST OF THIS WORK SHALL NOT BE COMPENSATED FOR SEPARATELY BUT SHALL BE INCLUDED IN THE UNIT BID PRICE FOR VARIOUS REMOVAL ITEMS.

EXISTING UNDERGROUND UTILITIES STAKED OR OTHERWISE MARKED AT THE SITE.

10. THE CONTRACTOR SHALL PROVIDE ADEQUATE PROVISIONS FOR PEDESTRIAN TRAFFIC THROUGH THE CONSTRUCTION AREA AT ALL TIMES AND SEEK THE VILLAGE'S PERMISSION FOR ANY UNAVOIDABLE OBSTRUCTION(S) TO SUCH TRAFFIC.
11. LOCAL ACCESS ON ALL SECONDARY STREETS MUST BE MAINTAINED AT ALL TIMES BY THE CONTRACTOR WHEN CONSTRUCTION IS NOT TAKING PLACE AT SUCH LOCATION. ALL TRAFFIC OBSTRUCTIONS TO SUCH STREETS SHALL BE REMOVED ON WEEKENDS, HOLIDAYS AND OVERNIGHT, UNLESS SPECIFICALLY AND EXPLICITLY PERMITTED BY THE VILLAGE.
12. REMOVAL AND STABILIZATION OF UNSTABLE MATERIAL:
THIS WORK, IF REQUIRED, SHALL BE DONE IN ACCORDANCE WITH THE SPECIAL PROVISION TITLED POROUS GRANULAR EMBANKMENT, SUBGRADE INCLUDED IN THE CONTRACT, SUBJECT TO THE FOLLOWING:
"POROUS GRANULAR EMBANKMENT, SUBGRADE" (PGES) HAS BEEN PROVIDED FOR THE USE AT THE LOCATIONS INDICATED FOR SOILS THAT TEND TO BE UNSTABLE. THE ACTUAL NEED FOR REMOVAL AND REPLACEMENT WITH PGES WILL BE DETERMINED IN THE FIELD AT THE TIME OF CONSTRUCTION BY THE GEOTECHNICAL ENGINEER. ALL POTENTIALLY UNSTABLE SOILS SHOULD BE TESTED WITH STATIC CONE PENETROMETER AND TREATED IN ACCORDANCE WITH ARTICLE 301.03 AND THE UNDERCUT GUIDELINES IN THE IDOT SUBGRADE STABILITY MANUAL. IF UNSTABLE MATERIAL IS NOT ENCOUNTERED AT THE SITE, THEN THE QUANTITY OF THIS ITEM WILL BE DEDUCTED FROM THE CONTRACT AND NO COMPENSATION FOR THIS ITEM WILL BE DUE TO THE CONTRACTOR.

LIST OF IDOT STANDARDS

STANDARD NO.	NAME OF STANDARD
000001-05	STANDARD SYMBOLS
424001-05	CURB RAMPS FOR SIDEWALKS
442201-03	CLASS C & D PATCHES
606001-03	CONCRETE CURB TYPE B AND COMBINATION CONCRETE CURB AND GUTTER
701301-02	LANE CLOSURE, 2L, 2W, SHORT TIME OPERATIONS
701501-04	URBAN LANE CLOSURE, 2L, 2W, UNDIVIDED
701801-03	URBAN LANE CLOSURE, MULTILANE 1W OR 2W CROSSWALK OR SIDEWALK CLOSURE
701901	TRAFFIC CONTROL DEVICES

CIVIL / STRUCTURAL ENGINEERS



GLOBETROTTERS INTERNATIONAL.
300 SOUTH WACKER DRIVE, SUITE 200
CHICAGO, IL. 60606

REVISIONS	
NAME	DATE
IDOT COMMENTS	02/25/08
IDOT COMMENTS	03/18/08

MFT 07-00071-00-RS
GENERAL NOTES

HAZEL CREST, IL
PROJECT NO. 05726-010

SCALE: VERT. NONE
HORIZ. NONE
DATE 12/18/07

DRAWN BY BS
CHECKED BY NC

FAU RTE. 285 3501	SECTION •	COUNTY COOK	TOTAL SHEETS 16	SHEET NO. 3
STA. N/A	TO STA. N/A		N/A	
FED. ROAD DIST. NO. ILLINOIS • 07-00071-00-RS				

SUMMARY OF QUANTITIES

ITEM NUMBER	CODED ITEM NUMBER	ITEM DESCRIPTION	UNIT	QUANTITY 1000
1	20700420	POROUS GRANULAR EMBANKMENT, SUBGRADE	CU YD	40
2	21101615	TOPSOIL FURNISH AND PLACE, 4"	SQ YD	435
3	25200200	SUPPLEMENTAL WATERING	UNIT	5
4	25200700	SODDING, SPECIAL	SQ YD	435
5	40600100	BITUMINOUS MATERIALS (PRIME COAT)	GALLON	1,900
6	40600982	HOT-MIX ASPHALT SURFACE REMOVAL - BUTT JOINT	SQ YD	1,400
7	40603310	HOT-MIX ASPHALT SURFACE COURSE, MIX "C", N50	TON	1,750
8	42400200	PORTLAND CEMENT CONCRETE SIDEWALK 5 INCH	SQ FT	2,200
9	42400800	DETECTABLE WARNINGS	SQ FT	440
10	44000198	HOT-MIX ASPHALT SURFACE REMOVAL - VARIABLE DEPTH	SQ YD	6,000
11	44000600	SIDEWALK REMOVAL	SQ FT	2,200
12	44001700	COMBINATION CONCRETE CURB AND GUTTER REMOVAL AND REPLACEMENT	FOOT	200
13	44201721	CLASS D PATCHES, TYPE III, 6 INCH	SQ YD	50
14	44201723	CLASS D PATCHES, TYPE IV, 6 INCH	SQ YD	950
15	60255500	MANHOLES TO BE ADJUSTED	EACH	6
16	60265700	VALVE VAULTS TO BE ADJUSTED	EACH	3
17	60266600	VALVE BOXES TO BE ADJUSTED	EACH	2
18	60300310	FRAMES AND LIDS TO BE ADJUSTED (SPECIAL)	EACH	6
19	67100100	MOBILIZATION	L SUM	1
20	70102620	TRAFFIC CONTROL AND PROTECTION, STANDARD 701501	L SUM	1
21	70102640	TRAFFIC CONTROL AND PROTECTION, STANDARD 701801	L SUM	1
*	22	78000400	THERMOPLASTIC PAVEMENT MARKING - LINE 6"	FOOT 1,370
*	23	78000600	THERMOPLASTIC PAVEMENT MARKING - LINE 12"	FOOT 400
*	24	78000650	THERMOPLASTIC PAVEMENT MARKING - LINE 24"	FOOT 108
25	X0322052	ASPHALT REJUVENATING AGENT	GALLON	2,500
26	X0324096	HOT IN-PLACE RECYCLING	SQ YD	19,000

* DENOTES SPECIALTY ITEMS

HOT-MIX ASPHALT MIXTURE REQUIREMENTS

MIXTURE TYPE	AC TYPE	AIR VOIDS
HOT-MIX ASPHALT SURFACE COURSE, MIX "C", N50 (IL-9.5mm)	PG 64-22	4% @ 50 GYR
CLASS D PATCHES, TYPE III, 6 INCH (BINDER IL-19 mm)	PG 64-22 **	4% @ 70 GYR
CLASS D PATCHES, TYPE IV, 6 INCH (BINDER IL-19 mm)	PG 64-22 **	4% @ 70 GYR

NOTES:

1. UNIT WEIGHT USED TO MEASURE ALL HOT-MIX ASPHALT SURFACE COURSE QUANTITY IS 112 LBS/SQ. YD./INCH
2. **WHEN RAP EXCEEDS 20%, THE NEW ASPHALT BINDER IN THE MIX SHALL BE PG 58-22

POROUS GRANULAR EMBANKMENT:

POROUS GRANULAR EMBANKMENT, SUBGRADE HAS BEEN PROVIDED IN THIS CONTRACT FOR USE AT THE LOCATIONS WHERE UNSUITABLE OR UNSTABLE SOILS MIGHT BE ENCOUNTERED DURING CONSTRUCTION AND SHALL NEED TO BE REMOVED AND REPLACED BY THIS MATERIAL. THE ACTUAL NEED FOR THIS WORK SHALL BE DETERMINED BY THE ENGINEER AT THE SITE(S). THE REQUIRED MATERIAL, METHOD OF MEASUREMENT AND BASIS OF PAYMENT FOR THIS WORK IS DESCRIBED ELSEWHERE IN THE CONTRACT AND PAYMENT WILL BE MADE FOR ONLY THE ACTUAL QUANTITY USED IN THE PROJECT WITHOUT ANY PRICE ADJUSTMENT FOR A CHANGE IN ITS QUANTITY. IF UNSUITABLE OR UNSTABLE SOILS ARE NOT ENCOUNTERED THEN THE QUANTITY OF THIS MATERIAL WILL BE DELETED FROM THE CONTRACT WITHOUT ANY PAYMENT DUE TO THE CONTRACTOR.

CIVIL / STRUCTURAL ENGINEERS



GLOBETROTTERS INTERNATIONAL,
300 SOUTH WACKER DRIVE, SUITE 200
CHICAGO, IL. 60606

REVISIONS	
NAME	DATE
IDOT COMMENTS	02/25/08
IDOT COMMENTS	03/18/08

MFT 07-00071-00-RS
SUMMARY OF QUANTITIES

HAZEL CREST, IL
PROJECT NO. 05726-010

SCALE: VERT. NONE
HORIZ. NONE
DATE 12/18/07

DRAWN BY BS
CHECKED BY NC

FAU RTE.	SECTION	COUNTY	TOTAL SHEETS	SHEET NO.
288-3601		COOK	16	4
STA.	TO STA.			

FED. ROAD DIST. NO. ILLINOIS
 • 07-00071-00-RS
 • STA 11+06.03 TO STA 30+24.55 @ APPLE TREE DR. AND
 STA 40+00 TO STA 63+60 @ LAUREL LN.

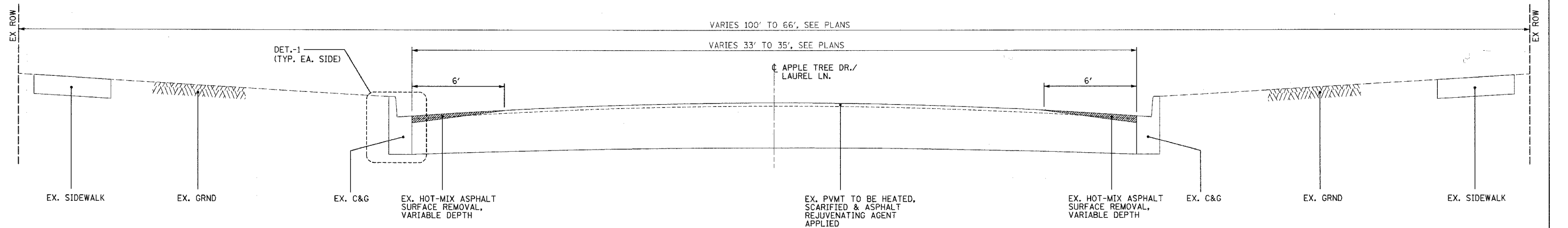

EXISTING TYP. X-SECTION
 APPLE TREE DR. (STA 11+06.03 TO STA 30+24.55)
 AND
 LAUREL LN. (STA 40+00 TO STA 63+60)

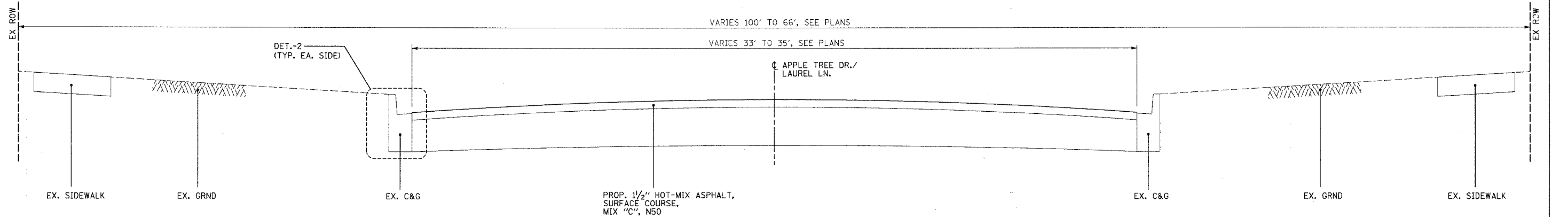

PROPOSED TYP. X-SECTION
 APPLE TREE DR. (STA 11+06.03 TO STA 30+24.55)
 AND
 LAUREL LN. (STA 40+00 TO STA 63+60)

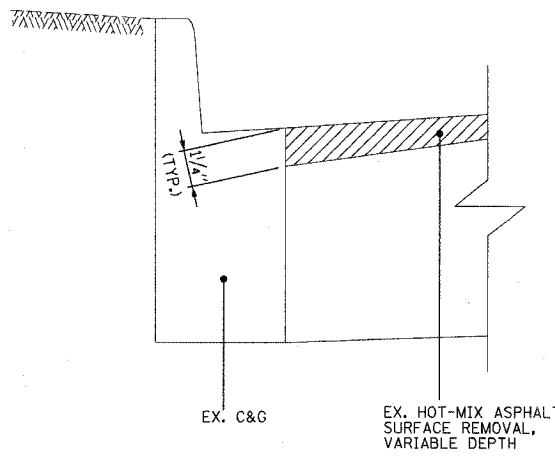

DETAIL-1

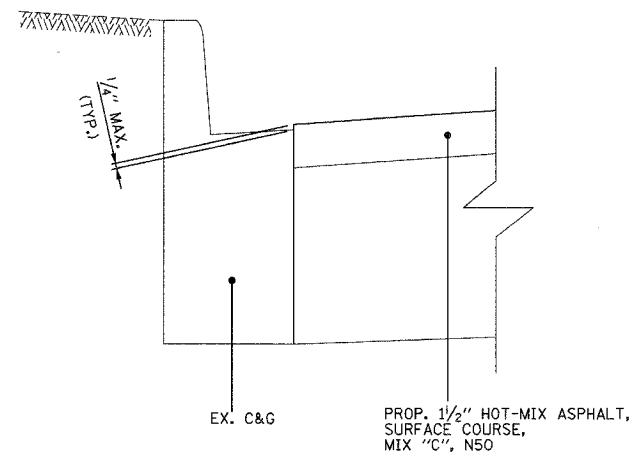

DETAIL-2

CIVIL / STRUCTURAL ENGINEERS

 GLOBETROTTERS INTERNATIONAL
 300 SOUTH WACKER DRIVE, SUITE 200
 CHICAGO, IL. 60606

REVISIONS	
NAME	DATE
DDOT COMMENTS	02/25/08
DDOT COMMENTS	03/18/08

MFT 07-00071-00-RS
 TYPICAL CROSS SECTIONS
 HAZEL CREST, IL
 PROJECT NO. 05726-010
 SCALE: VERT. NONE
 HORIZ. NONE
 DATE 12/18/07
 DRAWN BY BS
 CHECKED BY NC

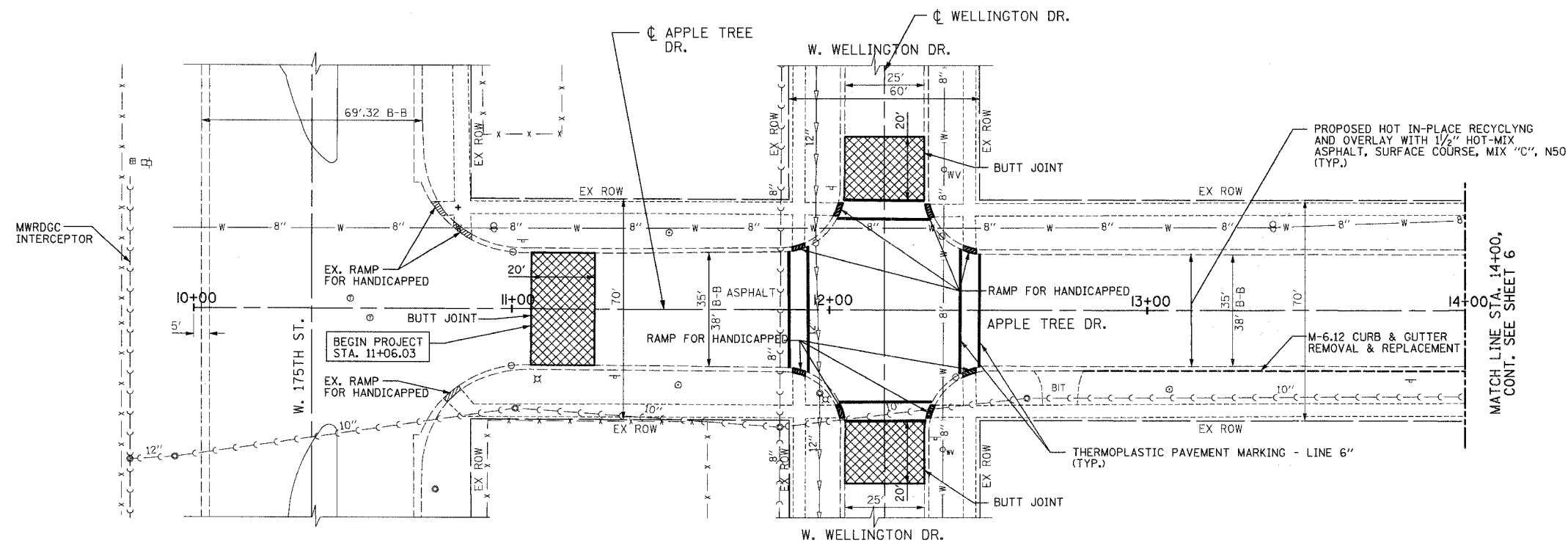
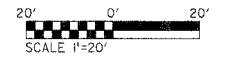
FAU RTE.	SECTION	COUNTY	TOTAL SHEETS	SHEET NO.
2826		COOK	16	5
STA. 10+00.00		TO STA. 14+00		
FED. ROAD DIST. NO.		ILLINOIS		
• 07-00071-00-RS				



MATCH LINE STA. 14+00. CONT. SEE SHEET 6

EXISTING LEGEND:		PROPOSED LEGEND:	
	- STORM SEWER		- WATER VALVE
	- SANITARY SEWER		- VALVE VAULT
	- WATER LINE		- FIRE HYDRANT
	- GAS LINE		- GAS VALVE
	- TELEPHONE LINE		- GAS VAULT
	- COMED LINE		- LIGHT POLE
	- CABLE LINE		- POWER POLE
	- CATCH BASIN		- GUY
	- SEWER MANHOLE		- STRUCTURE TO INLET
	- TELEPHONE MANHOLE		
			- BUTT JOINT
			- PAVEMENT PATCH
			- RAMP FOR HANDICAF
			- CROSSWALK

NOTE:
THE REPLACEMENT CURB & GUTTER SHALL BE CONSTRUCTED IN ACCORDANCE WITH SEC. 606 OF THE STANDARD SPECIFICATIONS, CONFORM WITH IDOT HIGHWAY STANDARD #606001, AND BE OF THE TYPE AND DIMENSIONS OF THAT EXISTING AT EACH LOCATION, EXCEPT THAT A DEPRESSED CURB SECTION SHALL BE CONSTRUCTED AT SIDEWALK.

NOTE:
AFTER A SATISFACTORY COMPLETION OF HOT-MIX SURFACE REMOVAL ^{1 1/2}/₂ BUTT JOINT AND VARIABLE DEPTH, AND HOT IN-PLACE RECYCLING OPERATIONS, AN OVERLAY OF 1 3/4 INCH HOT-MIX ASPHALT SURFACE COURSE, MIX 1/2 C 3/2 N50 SHALL BE CONSTRUCTED OVER THE ENTIRE PAVEMENT WIDTH.

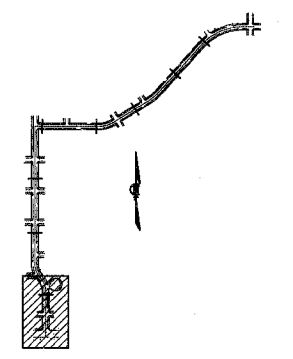

KEY PLAN

CIVIL / STRUCTURAL ENGINEERS



GLOBETROTTERS INTERNATIONAL,
300 SOUTH WACKER DRIVE, SUITE 200
CHICAGO, IL. 60606

REVISIONS	
NAME	DATE
IDOT COMMENTS	02/25/08
IDOT COMMENTS	03/18/08

MFT 07-00071-00-RS
APPLE TREE DRIVE (FAU 2826)
175TH ST. TO LAUREL LN.

HAZEL CREST, IL
PROJECT NO. 05726-010

SCALE: VERT. NONE
HORIZ. 1" = 20'
DATE 12/18/07

DRAWN BY BS
CHECKED BY NC

FAU RTE. 2826, 3801	SECTION	COUNTY COOK	TOTAL SHEETS 16	SHEET NO. 6
STA. 14+00		TO STA. 20+00		
FED. ROAD DIST. NO.		ILLINOIS		
• 07-00071-00-RS				

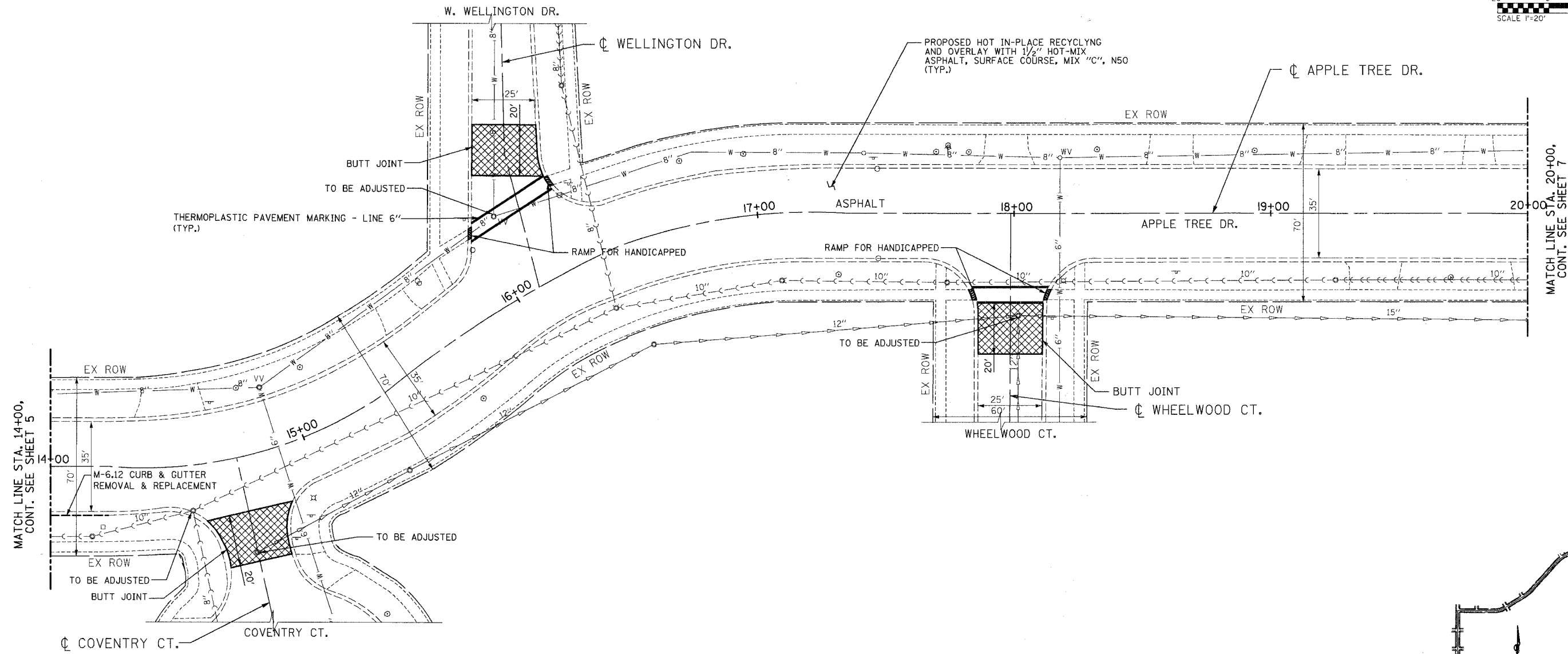
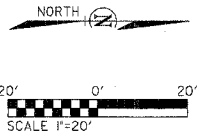

MATCH LINE STA. 14+00, CONT. SEE SHEET 5

MATCH LINE STA. 20+00, CONT. SEE SHEET 7

EXISTING LEGEND:		PROPOSED LEGEND:	
	- STORM SEWER		- WATER VALVE
	- SANITARY SEWER		- VALVE VAULT
	- WATER LINE		- FIRE HYDRANT
	- GAS LINE		- GAS VALVE
	- TELEPHONE LINE		- GAS VAULT
	- COMED LINE		- LIGHT POLE
	- CABLE LINE		- POWER POLE
	- CATCH BASIN		- GUY
	- SEWER MANHOLE		- STRUCTURE TO
	- INLET		
	- TELEPHONE MANHOLE		
			- BUTT JOINT
			- PAVEMENT PATCH
			- RAMP FOR HANDICAP
			- CROSSWALK

NOTE:
THE REPLACEMENT CURB & GUTTER SHALL BE CONSTRUCTED IN ACCORDANCE WITH SEC. 606 OF THE STANDARD SPECIFICATIONS, CONFORM WITH IDOT HIGHWAY STANDARD #606001, AND BE OF THE TYPE AND DIMENSIONS OF THAT EXISTING AT EACH LOCATION, EXCEPT THAT A DEPRESSED CURB SECTION SHALL BE CONSTRUCTED AT SIDEWALK.

NOTE:
AFTER A SATISFACTORY COMPLETION OF HOT-MIX SURFACE REMOVAL $\frac{1}{2}$ " BUTT JOINT AND VARIABLE DEPTH, AND HOT IN-PLACE RECYCLING OPERATIONS, AN OVERLAY OF $\frac{1}{2}$ " INCH HOT-MIX ASPHALT SURFACE COURSE, MIX $\frac{1}{2}$ C $\frac{1}{2}$ N50 SHALL BE CONSTRUCTED OVER THE ENTIRE PAVEMENT WIDTH.

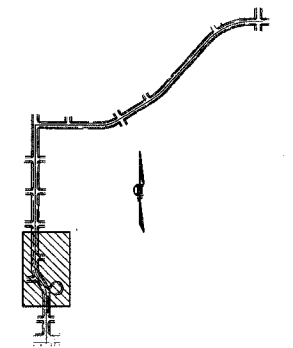

KEY PLAN

CIVIL / STRUCTURAL ENGINEERS



GLOBETROTTERS INTERNATIONAL.
300 SOUTH WACKER DRIVE, SUITE 200
CHICAGO, IL. 60606

REVISIONS	
NAME	DATE
IDOT COMMENTS	02/25/08
IDOT COMMENTS	03/18/08

MFT 07-00071-00-RS
APPLE TREE DRIVE (FAU 2826)
175TH ST. TO LAUREL LN.
HAZEL CREST, IL
PROJECT NO. 05726-010

SCALE: VERT. NONE
HORIZ. 1" = 20'
DATE 12/18/07

DRAWN BY BS
CHECKED BY NC

FAU RTE.	SECTION	COUNTY	TOTAL SHEETS	SHEET NO.
2826		COOK	16	7
STA. 20+00		TO STA. 25+00		
FED. ROAD DIST. NO.		ILLINOIS		
• 07-00071-00-RS				

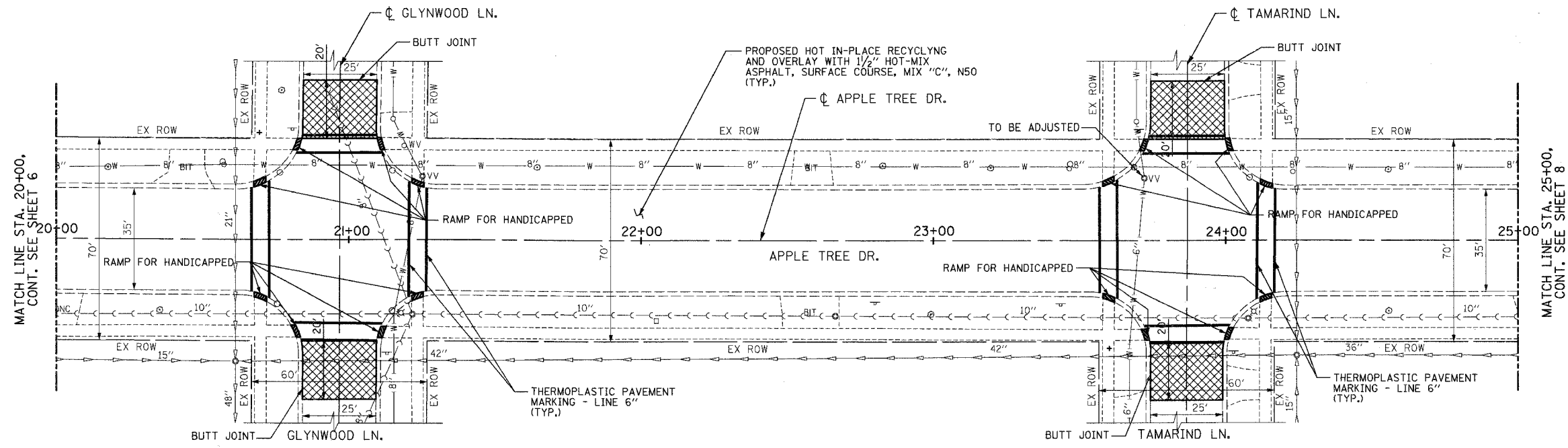
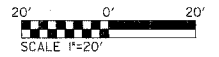
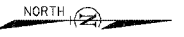

MATCH LINE STA. 20+00.
CONT. SEE SHEET 6

MATCH LINE STA. 25+00.
CONT. SEE SHEET 8

EXISTING LEGEND:		PROPOSED LEGEND:	
	- STORM SEWER		- WATER VALVE
	- SANITARY SEWER		- VALVE VAULT
	- WATER LINE		- FIRE HYDRANT
	- GAS LINE		- GAS VALVE
	- TELEPHONE LINE		- GAS VAULT
	- COMED LINE		- LIGHT POLE
	- CABLE LINE		- POWER POLE
	- CATCH BASIN		- GUY
	- SEWER MANHOLE		- STRUCTURE TO
	- INLET		
	- TELEPHONE MANHOLE		- BUTT JOINT
			- PAVEMENT PATCH
			- RAMP FOR HANDICAPP
			- CROSSWALK

NOTE:
AFTER A SATISFACTORY COMPLETION OF HOT-MIX SURFACE REMOVAL $\frac{1}{2}$ BUTT JOINT AND VARIABLE DEPTH, AND HOT IN-PLACE RECYCLING OPERATIONS, AN OVERLAY OF $1\frac{1}{2}$ INCH HOT-MIX ASPHALT SURFACE COURSE, MIX $\frac{1}{2}$ C $\frac{1}{2}$ N50 SHALL BE CONSTRUCTED OVER THE ENTIRE PAVEMENT WIDTH.

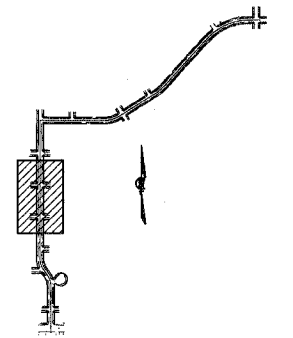

KEY PLAN

CIVIL / STRUCTURAL ENGINEERS



GLOBETROTTERS INTERNATIONAL.
300 SOUTH WACKER DRIVE, SUITE 200
CHICAGO, IL. 60606

REVISIONS	
NAME	DATE
DOT COMMENTS	02/25/08
DOT COMMENTS	03/18/08

MFT 07-00071-00-RS
APPLE TREE DRIVE (FAU 2826)
175TH ST. TO LAUREL LN.

HAZEL CREST, IL
PROJECT NO. 05726-010

SCALE: VERT. NONE
HORIZ. 1" = 20'
DATE 12/18/07

DRAWN BY BS
CHECKED BY NC

FAU RTE.	SECTION	COUNTY	TOTAL SHEETS	SHEET NO.
2826		COOK	16	8
STA. 25+00		TO STA. 30+50		
FED. ROAD DIST. NO.		ILLINOIS		
• 07-00071-00-RS				

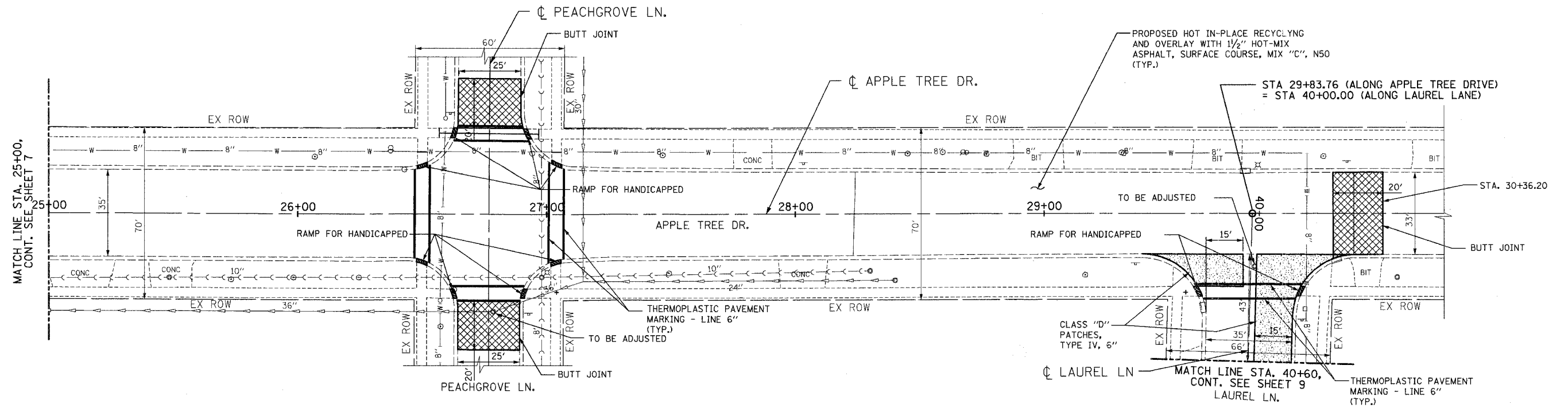
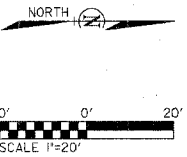

EXISTING LEGEND:		PROPOSED LEGEND:	
	- STORM SEWER		- BUTT JOINT
	- SANITARY SEWER		- PAVEMENT PATCH
	- WATER LINE		- RAMP FOR HANDICAPPED
	- GAS LINE		- CROSSWALK
	- TELEPHONE LINE		
	- COMED LINE		
	- CABLE LINE		
	- CATCH BASIN		
	- SEWER MANHOLE		
	- INLET		
	- TELEPHONE MANHOLE		
	- WATER VALVE		
	- VALVE VAULT		
	- FIRE HYDRANT		
	- GAS VALVE		
	- GAS VAULT		
	- LIGHT POLE		
	- POWER POLE		
	- GUY		
	- STRUCTURE TO		

NOTE:

AFTER A SATISFACTORY COMPLETION OF HOT-MIX SURFACE REMOVAL $\frac{1}{2}$ BUTT JOINT AND VARIABLE DEPTH, AND HOT IN-PLACE RECYCLING OPERATIONS, AN OVERLAY OF $1\frac{1}{2}$ INCH HOT-MIX ASPHALT SURFACE COURSE, MIX $\frac{1}{2}$ C $\frac{1}{2}$ N50 SHALL BE CONSTRUCTED OVER THE ENTIRE PAVEMENT WIDTH.

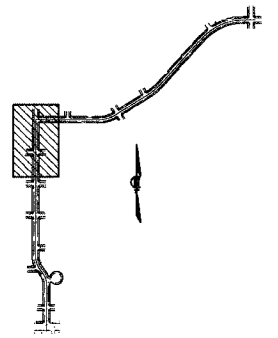

KEY PLAN

REVISIONS	
NAME	DATE
DDOT COMMENTS	02/25/08
DDOT COMMENTS	03/18/08

MFT 07-00071-00-RS
APPLE TREE DRIVE (FAU 2826)
175TH ST. TO LAUREL LN.

HAZEL CREST, IL
PROJECT NO. 05726-010

SCALE: VERT. NONE
HORIZ. 1" = 20'
DATE 12/18/07

DRAWN BY BS
CHECKED BY NC

CIVIL / STRUCTURAL ENGINEERS



GLOBETROTTERS INTERNATIONAL.
300 SOUTH WACKER DRIVE, SUITE 200
CHICAGO, IL. 60606

FAU RTE.	SECTION	COUNTY	TOTAL SHEETS	SHEET NO.
360		COOK	16	9
STA. 30+50		TO STA. 35+50		
FED. ROAD DIST. NO.		ILLINOIS		
• 07-00071-00-RS				

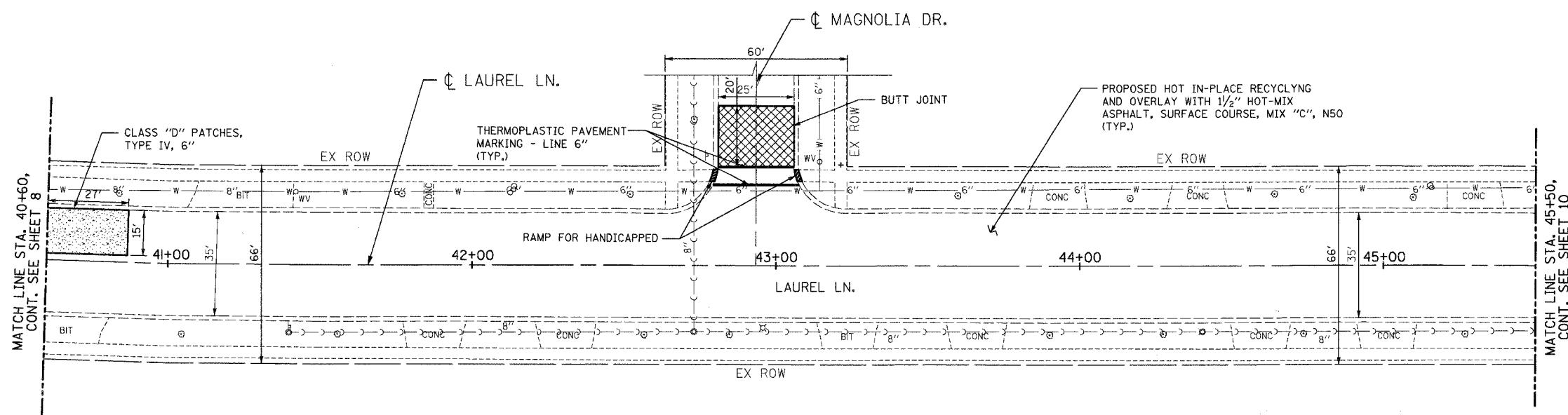
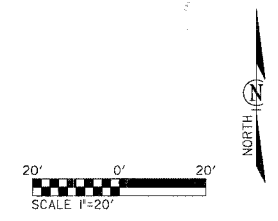

EXISTING LEGEND:		PROPOSED LEGEND:	
	- STORM SEWER		- WATER VALVE
	- SANITARY SEWER		- VALVE VAULT
	- WATER LINE		- FIRE HYDRANT
	- GAS LINE		- GAS VALVE
	- TELEPHONE LINE		- GAS VAULT
	- COMED LINE		- LIGHT POLE
	- CABLE LINE		- POWER POLE
	- CATCH BASIN		- GUY
	- SEWER MANHOLE		- STRUCTURE TO
	- INLET		
	- TELEPHONE MANHOLE		- BUTT JOINT
			- PAVEMENT PATCH
			- RAMP FOR HANDICAPP
			- CROSSWALK

NOTE:
 AFTER A SATISFACTORY COMPLETION OF HOT-MIX SURFACE REMOVAL $\frac{3}{4}$ BUTT JOINT AND VARIABLE DEPTH, AND HOT IN-PLACE RECYCLING OPERATIONS, AN OVERLAY OF $1\frac{1}{4}$ INCH HOT-MIX ASPHALT SURFACE COURSE, MIX $\frac{7}{32}$ C $\frac{1}{32}$ N50 SHALL BE CONSTRUCTED OVER THE ENTIRE PAVEMENT WIDTH.

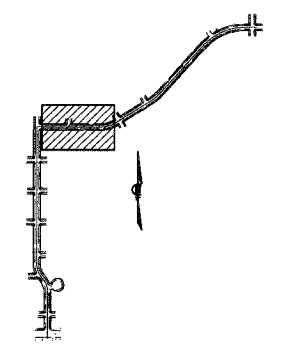

KEY PLAN

CIVIL / STRUCTURAL ENGINEERS



GLOBETROTTERS INTERNATIONAL
 300 SOUTH WACKER DRIVE, SUITE 200
 CHICAGO, IL. 60606

REVISIONS	
NAME	DATE
DDOT COMMENTS	02/25/08
DDOT COMMENTS	03/18/08

MFT 07-00071-00-RS
 LAUREL LANE (FAU 3601)
 APPLE TREE DR. TO ELM DR.
 HAZEL CREST, IL
 PROJECT NO. 05726-010

SCALE: VERT. NONE
 HORIZ. 1" = 20'
 DATE 12/18/07
 DRAWN BY BS
 CHECKED BY NC

FAU R.T.E. 2826-3601	SECTION	COUNTY	TOTAL SHEETS	SHEET NO.
		COOK	16	10
STA. 35+50		TO STA. 39+50		
FED. ROAD DIST. NO.		ILLINOIS		
• 07-00071-00-RS				

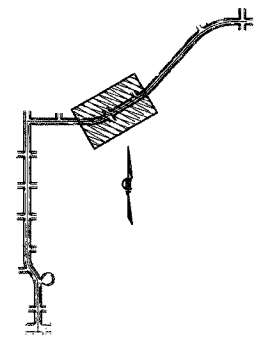
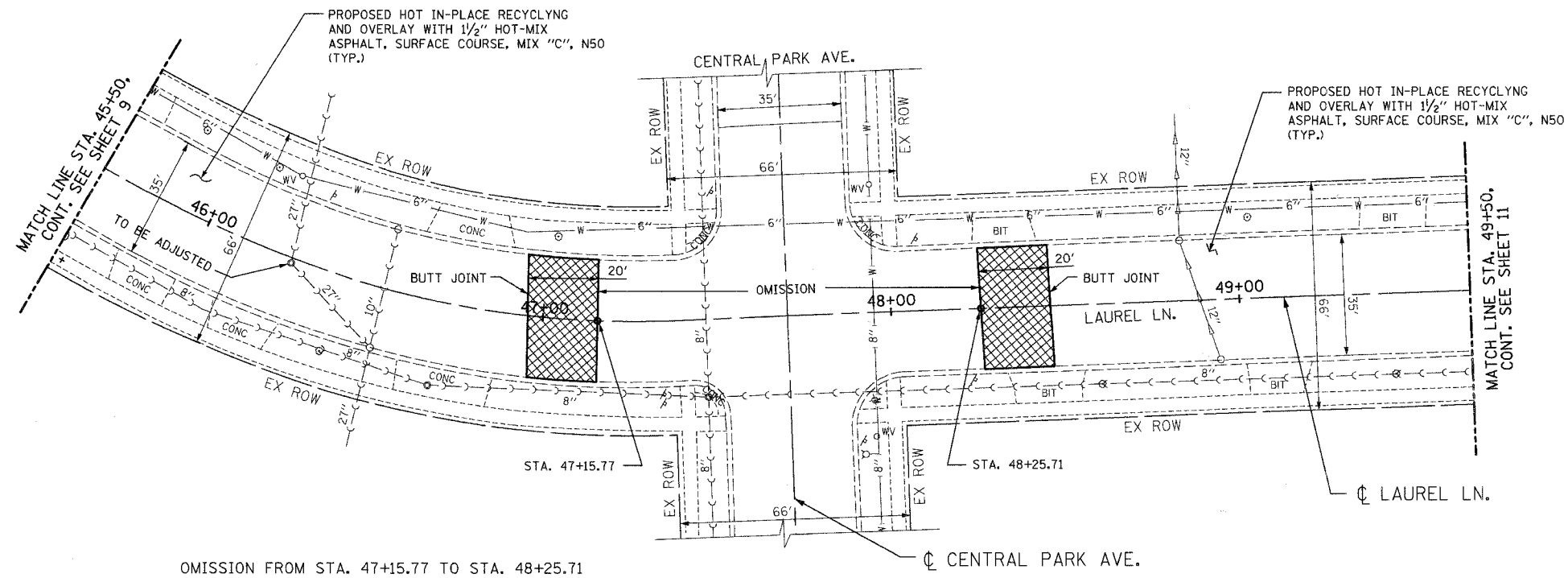
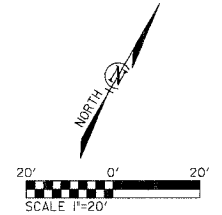

KEY PLAN

NOTE:

AFTER A SATISFACTORY COMPLETION OF HOT-MIX SURFACE REMOVAL 3/4" BUTT JOINT AND VARIABLE DEPTH, AND HOT IN-PLACE RECYCLING OPERATIONS, AN OVERLAY OF 1 1/2" INCH HOT-MIX ASPHALT SURFACE COURSE, MIX 1/2" C 1/2" N50 SHALL BE CONSTRUCTED OVER THE ENTIRE PAVEMENT WIDTH.

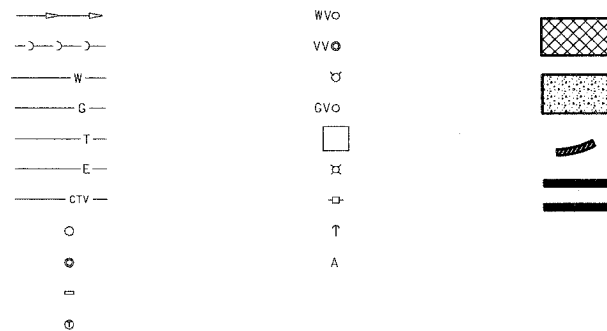

CIVIL / STRUCTURAL ENGINEERS



GLOBETROTTERS INTERNATIONAL,
300 SOUTH WACKER DRIVE, SUITE 200
CHICAGO, IL. 60606

REVISIONS	
NAME	DATE
DDOT COMMENTS	12/25/08
DDOT COMMENTS	03/18/08

MFT 07-00071-00-RS
LAUREL LANE (FAU 3601)
APPLE TREE DR. TO ELM DR.

HAZEL CREST, IL
PROJECT NO. 05726-010

SCALE: VERT. NONE
HORIZ. 1" = 20'
DATE 12/18/07

DRAWN BY BS
CHECKED BY NC

FAU R.T.E.	SECTION	COUNTY	TOTAL SHEETS	SHEET NO.
3601		COOK	16	11
STA. 39+50		TO STA. 44+50		
FED. ROAD DIST. NO.		ILLINOIS		
• 07-00071-00-RS				

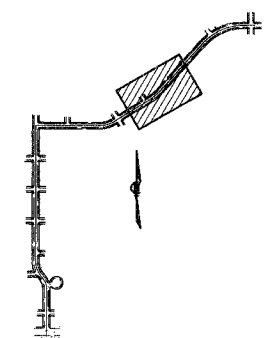
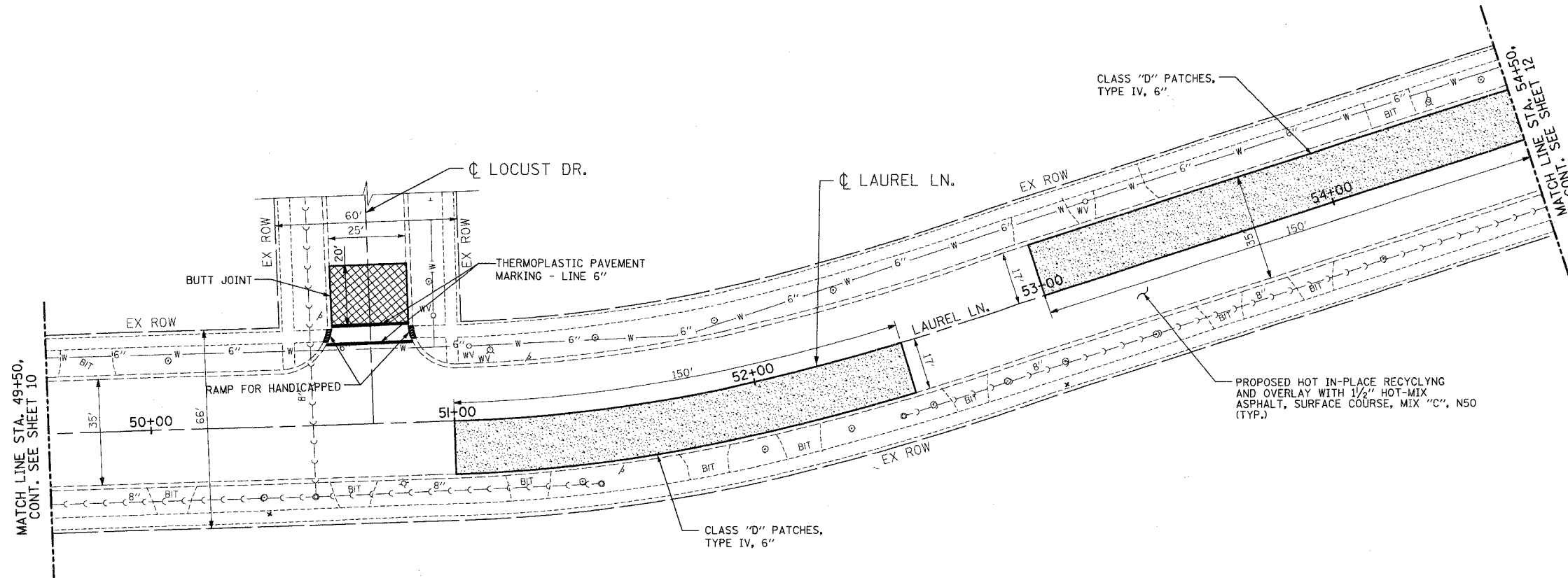
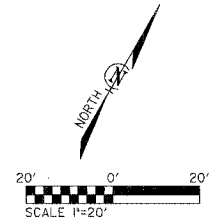

KEY PLAN

EXISTING LEGEND:		PROPOSED LEGEND:	
	- STORM SEWER		- BUTT JOINT
	- SANITARY SEWER		- PAVEMENT PATCH
	- WATER LINE		- RAMP FOR HANDICAPPED
	- GAS LINE		- CROSSWALK
	- TELEPHONE LINE		
	- COMED LINE		
	- CABLE LINE		
	- CATCH BASIN		
	- SEWER MANHOLE		
	- INLET		
	- TELEPHONE MANHOLE		
	- WATER VALVE		
	- VALVE VAULT		
	- FIRE HYDRANT		
	- GAS VALVE		
	- GAS VAULT		
	- LIGHT POLE		
	- POWER POLE		
	- GUY		
	- STRUCTURE TO		

NOTE:

AFTER A SATISFACTORY COMPLETION OF HOT-MIX SURFACE REMOVAL 1/2" BUTT JOINT AND VARIABLE DEPTH, AND HOT IN-PLACE RECYCLING OPERATIONS, AN OVERLAY OF 1 1/2" INCH HOT-MIX ASPHALT SURFACE COURSE, MIX 1/2" C 1/2" N50 SHALL BE CONSTRUCTED OVER THE ENTIRE PAVEMENT WIDTH.

CIVIL / STRUCTURAL ENGINEERS



GLOBETROTTERS INTERNATIONAL.
300 SOUTH WACKER DRIVE, SUITE 200
CHICAGO, IL. 60606

REVISIONS	
NAME	DATE
IDOT COMMENTS	02/28/08
IDOT COMMENTS	03/18/08

MFT 07-00071-00-RS
LAUREL LANE (FAU 3601)
APPLE TREE DR. TO ELM DR.
HAZEL CREST, IL
PROJECT NO. 05726-010

SCALE: VERT. NONE
HORIZ. 1" = 20'
DATE 12/18/07

DRAWN BY BS
CHECKED BY NC

FAU RTE.	SECTION	COUNTY	TOTAL SHEETS	SHEET NO.
2826 3601		COOK	16	12
STA. 44+50		TO STA. 48+50		
FED. ROAD DIST. NO.		ILLINOIS		
• 07-00071-00-R5				

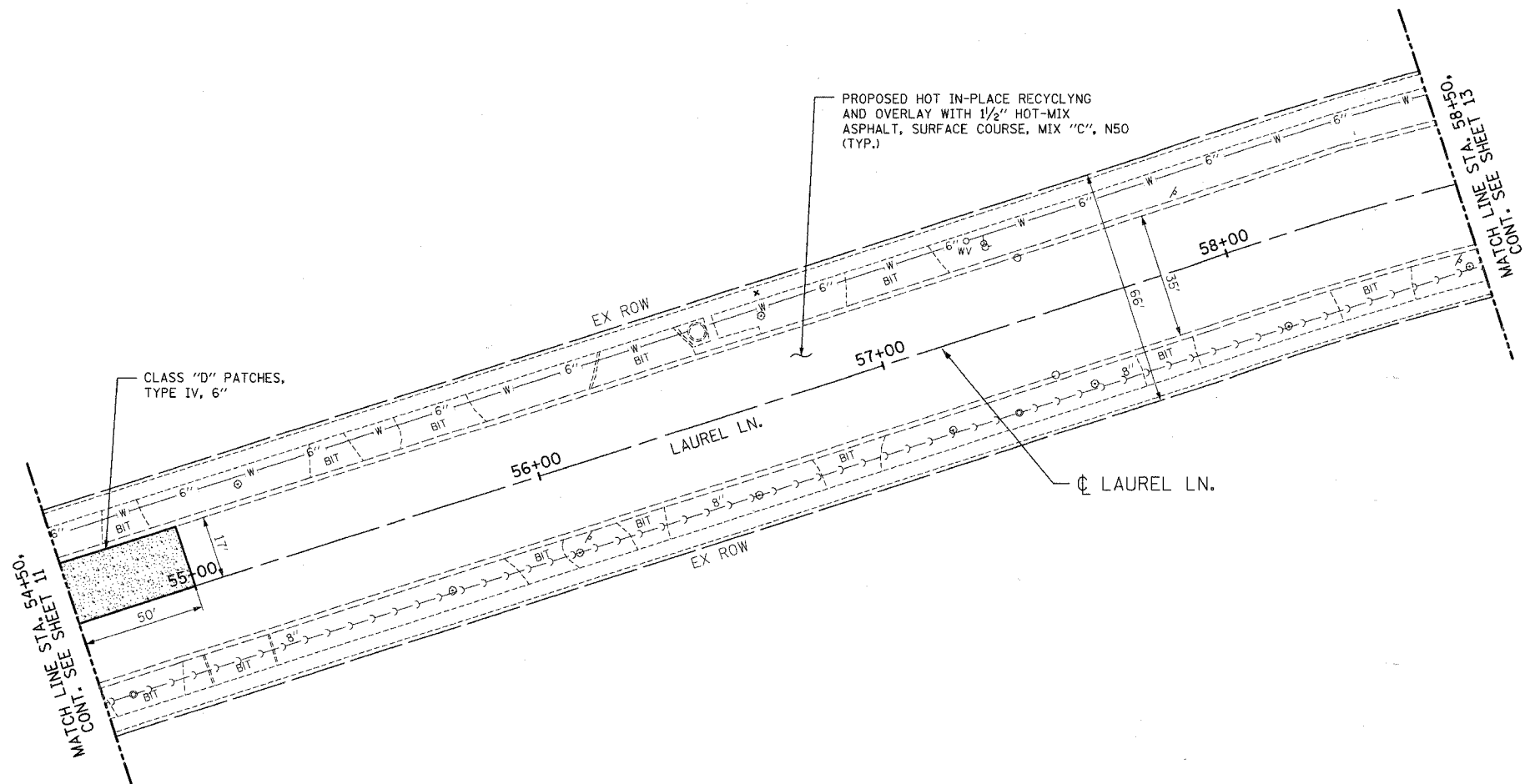
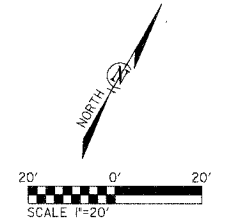

EXISTING LEGEND:		PROPOSED LEGEND:	
	- STORM SEWER		- WATER VALVE
	- SANITARY SEWER		- VALVE VAULT
	- WATER LINE		- FIRE HYDRANT
	- GAS LINE		- GAS VALVE
	- TELEPHONE LINE		- GAS VAULT
	- COMED LINE		- LIGHT POLE
	- CABLE LINE		- POWER POLE
	- CATCH BASIN		- GUY
	- SEWER MANHOLE		- STRUCTURE TO
	- INLET		
	- TELEPHONE MANHOLE		- BUTT JOINT
			- PAVEMENT PATCH
			- RAMP FOR HANDICAPPED
			- CROSSWALK

NOTE:
 AFTER A SATISFACTORY COMPLETION OF HOT-MIX SURFACE REMOVAL 1/2" BUTT JOINT AND VARIABLE DEPTH, AND HOT IN-PLACE RECYCLING OPERATIONS, AN OVERLAY OF 1 1/2" INCH HOT-MIX ASPHALT SURFACE COURSE, MIX 1/2" C 1/2" N50 SHALL BE CONSTRUCTED OVER THE ENTIRE PAVEMENT WIDTH.

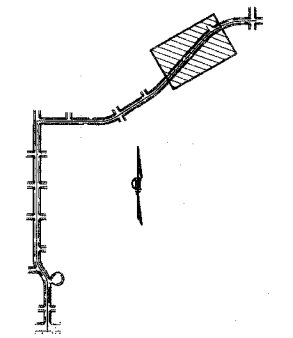

KEY PLAN

REVISIONS	
NAME	DATE
DDOT COMMENTS	02/25/08
DDOT COMMENTS	03/28/08

MFT 07-00071-00-RS
 LAUREL LANE (FAU 3601)
 APPLE TREE DR. TO ELM DR.
 HAZEL CREST, IL
 PROJECT NO. 05726-010
 SCALE: VERT. NONE
 HORIZ. 1" = 20'
 DATE 12/18/07
 DRAWN BY BS
 CHECKED BY NC

CIVIL / STRUCTURAL ENGINEERS

 GLOBETROTTERS INTERNATIONAL.
 300 SOUTH WACKER DRIVE, SUITE 200
 CHICAGO, IL. 60606

FAU RTE. 3601	SECTION	COUNTY	TOTAL SHEETS	SHEET NO.
		COOK	16	13
STA. 48+50		TO STA. 53+46		
FED. ROAD DIST. NO. ILLINOIS				
• 07-00071-00-RS				

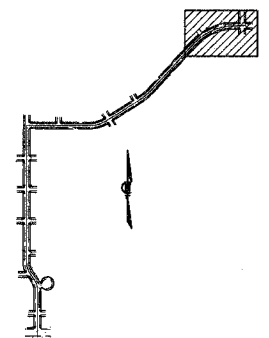
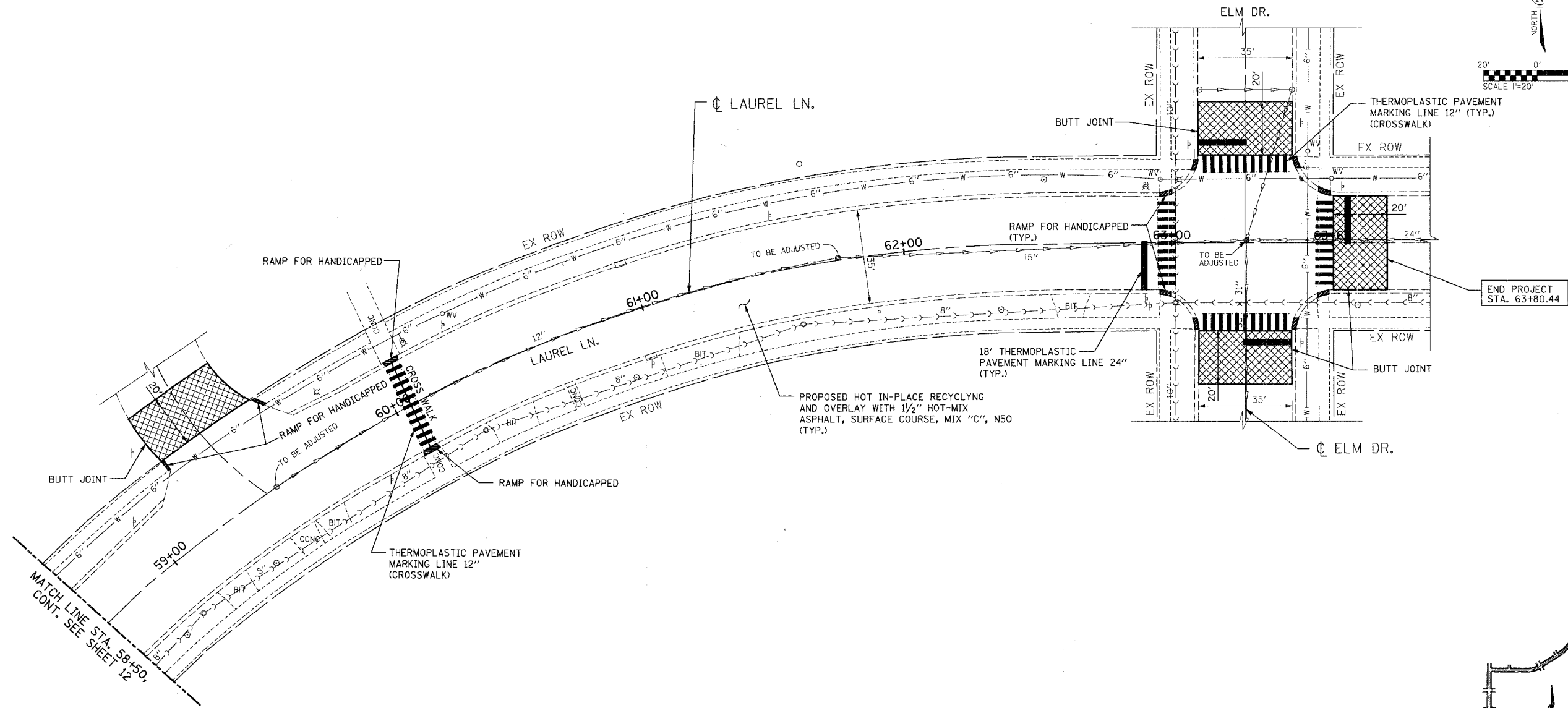
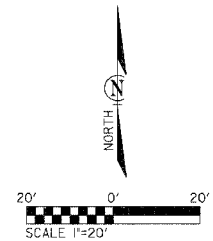

KEY PLAN

EXISTING LEGEND:		PROPOSED LEGEND:	
	- STORM SEWER		- WATER VALVE
	- SANITARY SEWER		- VALVE VAULT
	- WATER LINE		- FIRE HYDRANT
	- GAS LINE		- GAS VALVE
	- TELEPHONE LINE		- GAS VAULT
	- COMED LINE		- LIGHT POLE
	- CABLE LINE		- POWER POLE
	- CATCH BASIN		- GUY
	- SEWER MANHOLE		- STRUCTURE TO
	- INLET		
	- TELEPHONE MANHOLE		- BUTT JOINT
			- PAVEMENT PATCH
			- RAMP FOR HANDICAPPED
			- CROSSWALK

NOTE:

AFTER A SATISFACTORY COMPLETION OF HOT-MIX SURFACE REMOVAL ^{3/4}/₂, BUTT JOINT AND VARIABLE DEPTH, AND HOT IN-PLACE RECYCLING OPERATIONS, AN OVERLAY OF 1 ^{3/4}/₂ INCH HOT-MIX ASPHALT SURFACE COURSE, MIX ^{1/2}/₂ C³² N50 SHALL BE CONSTRUCTED OVER THE ENTIRE PAVEMENT WIDTH.

CIVIL / STRUCTURAL ENGINEERS



GLOBETROTTERS INTERNATIONAL.
300 SOUTH WACKER DRIVE, SUITE 200
CHICAGO, IL. 60606

REVISIONS	
NAME	DATE
DOT COMMENTS	02/25/08
DOT COMMENTS	03/18/08

MFT 07-00071-00-RS
LAUREL LANE (FAU 3601)
APPLE TREE DR. TO ELM DR.
HAZEL CREST, IL
PROJECT NO. 05726-010

SCALE: VERT. NONE
HORIZ. 1" = 20'
DATE 12/18/07

DRAWN BY BS
CHECKED BY NC

FAU RTE.	SECTION	COUNTY	TOTAL SHEETS	SHEET NO.
2825 SB01		COOK	16	14
STA. 48+50		TO STA. 53+46		
FED. ROAD DIST. NO.		ILLINOIS		
• 07-00071-00-RS				

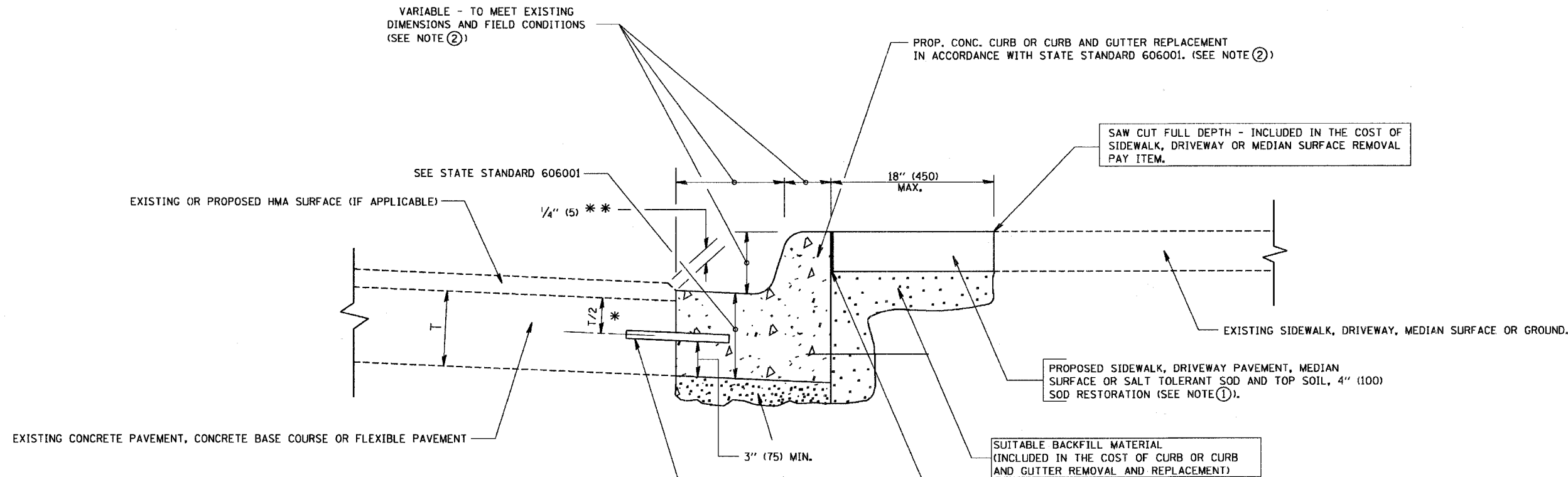

- * 3" (75) MINIMUM FROM TOP AND BOTTOM OF THE CONCRETE PAVEMENT OR BASE COURSE.
- * * IF THE FINAL SURFACE OF THE PAVEMENT IS CONCRETE, THE GUTTER IS TO BE FLUSH WITH THE PAVEMENT.

NOTE: ① SIDEWALK, DRIVEWAY PAVEMENT OR MEDIAN SURFACE SHALL BE SIMILAR TO THE MATERIAL BEING REMOVED AND WILL BE PAID FOR SEPARATELY.

SALT TOLERANT SOD AND TOP SOIL, 4" (100) RESTORATION WILL NOT BE PAID FOR SEPARATELY, BUT SHALL BE INCLUDED IN THE COST OF CURB OR CURB AND GUTTER REMOVAL AND REPLACEMENT.

- ② CURB OR CURB AND GUTTER REPLACEMENT SHALL MATCH THE SHAPE OF THE EXISTING CURB OR CURB AND GUTTER UNLESS OTHERWISE SPECIFIED.
- ③ FOR CURB OR CURB AND GUTTER REMOVAL AND REPLACEMENT ADJACENT TO FLEXIBLE PAVEMENT DELETE EPOXY COATED TIE BARS.
- ④ LONGITUDINAL BARS, IF ENCOUNTERED IN THE EXISTING CURB OR CURB AND GUTTER, ARE NOT TO BE REPLACED. CUTTING AND REMOVING LONGITUDINAL BARS SHALL BE INCLUDED IN THE COST OF CURB OR CURB AND GUTTER REMOVAL AND REPLACEMENT.
- ⑤ THE COST OF HMA SURFACE REMOVAL IN THE EXISTING GUTTER FLAG SHALL BE INCLUDED IN THE COST OF THE CURB AND GUTTER REMOVAL AND REPLACEMENT.
- ⑥ THE REMOVAL AND REPLACEMENT OF THE EXISTING CURB OR CURB AND GUTTER SHALL BE DONE IN ACCORDANCE WITH THE APPLICABLE PORTIONS OF SECTION 440 AND 606 OF THE STANDARD SPECIFICATIONS.
- ⑦ THE LOCATIONS OF REMOVAL AND REPLACEMENT OF EXISTING CURB OR CURB AND GUTTER SHALL BE DETERMINED BY THE RESIDENT ENGINEER AT THE TIME OF CONSTRUCTION.

PROPOSED 3/4" (20) PREFORMED EXPANSION JOINT AT CONCRETE SIDEWALKS, DRIVEWAYS, AND MEDIANS. (INCLUDED IN THE COST OF CURB OR CURB AND GUTTER REMOVAL AND REPLACEMENT.)

UNSUITABLE SUB-BASE MATERIAL TO BE REMOVED, IF DIRECTED BY THE ENGINEER, SHALL BE REPLACED WITH EITHER SUB-BASE GRANULAR MATERIAL, TYPE B OR ADDITIONAL THICKNESS OF CONCRETE.

REMOVAL AND REPLACEMENT 4" (100) OR LESS IS INCLUDED IN THE COST OF CURB OR CURB AND GUTTER REMOVAL AND REPLACEMENT.

REMOVAL AND REPLACEMENT IN EXCESS OF 4" (100) WILL BE PAID FOR IN ACCORDANCE WITH ARTICLE 109.04 OF THE STANDARD SPECIFICATIONS.

PROPOSED #6 (20) EPOXY COATED TIE BARS 24" (600) LONG AT 24" (600) CENTERS WILL NOT BE PAID FOR SEPARATELY. DELETE EPOXY COATED TIE BARS IF EXISTING TIE BARS ARE USUABLE AS DETERMINED BY THE ENGINEER. (SEE NOTE ③).

BASIS OF PAYMENT:
THIS WORK WILL BE PAID FOR AT THE CONTRACT UNIT PRICE PER FOOT (METER) FOR "CURB REMOVAL AND REPLACEMENT" OR "COMBINATION CONCRETE CURB AND GUTTER REMOVAL AND REPLACEMENT".

CURB OR CURB AND GUTTER REMOVAL AND REPLACEMENT

ALL DIMENSIONS ARE IN INCHES (MILLIMETERS) UNLESS OTHERWISE SHOWN.

FILE NAME = W:\distest\22\34\bd24.dgn	USER NAME = geglennob	DESIGNED - A. HOUSEH	REVISED - R. SHAH 10-03-96	STATE OF ILLINOIS DEPARTMENT OF TRANSPORTATION	CURB OR CURB AND GUTTER REMOVAL AND REPLACEMENT	F.A. RTE. SECTION COUNTY TOTAL SHEETS SHEET NO.
		DRAWN -	REVISED - A. ABBAS 03-21-97			
		CHECKED -	REVISED - M. GOMEZ 01-22-01			
		DATE - 03-11-94	REVISED - R. BORO 01-01-07			
				SCALE: NONE	SHEET NO. 1 OF 1 SHEETS	STA. TO STA.
						BD600-06 (BD-24) CONTRACT NO.
						FED. ROAD DIST. NO. 1 ILLINOIS FED. AID PROJECT

FAU RTE.	SECTION	COUNTY	TOTAL SHEETS	SHEET NO.
2826 3901		COOK	16	15
STA. 48+50		TO STA. 53+46		
FED. ROAD DIST. NO.		ILLINOIS		
* 07-00071-00-RS				

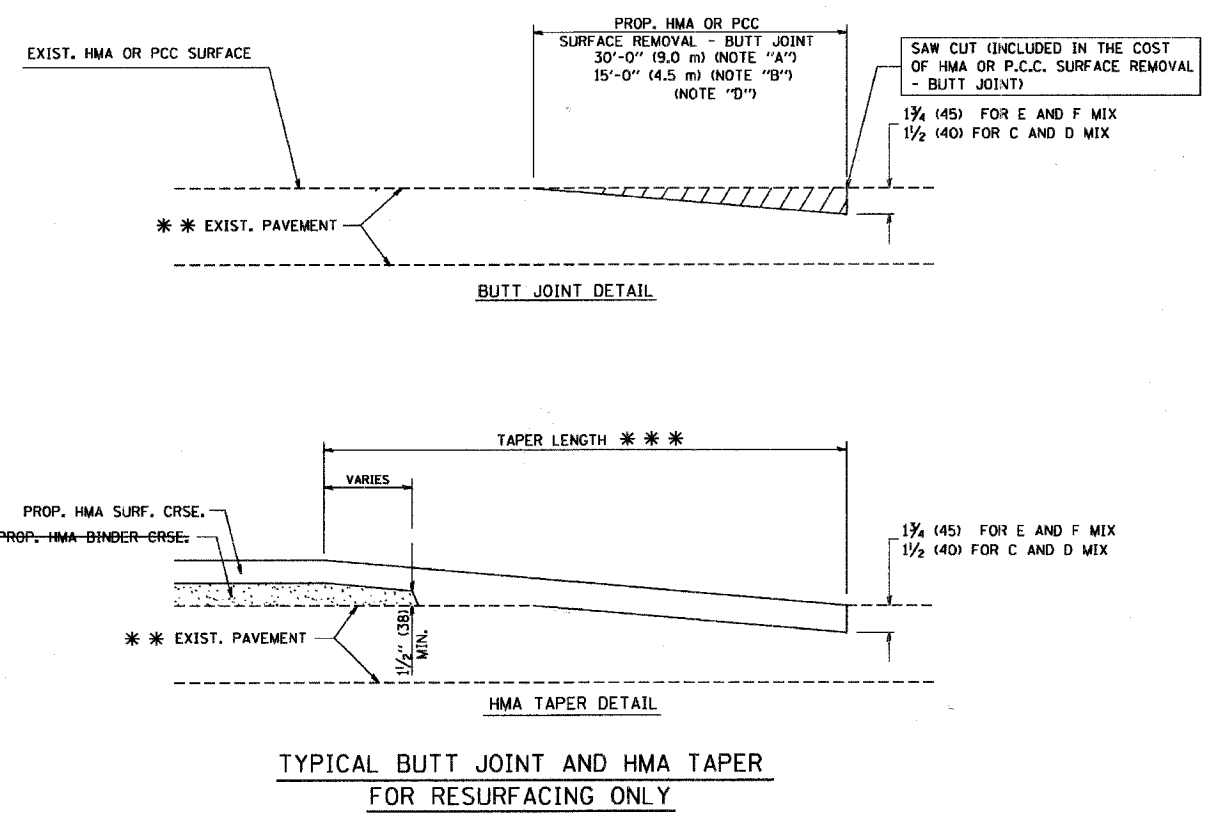
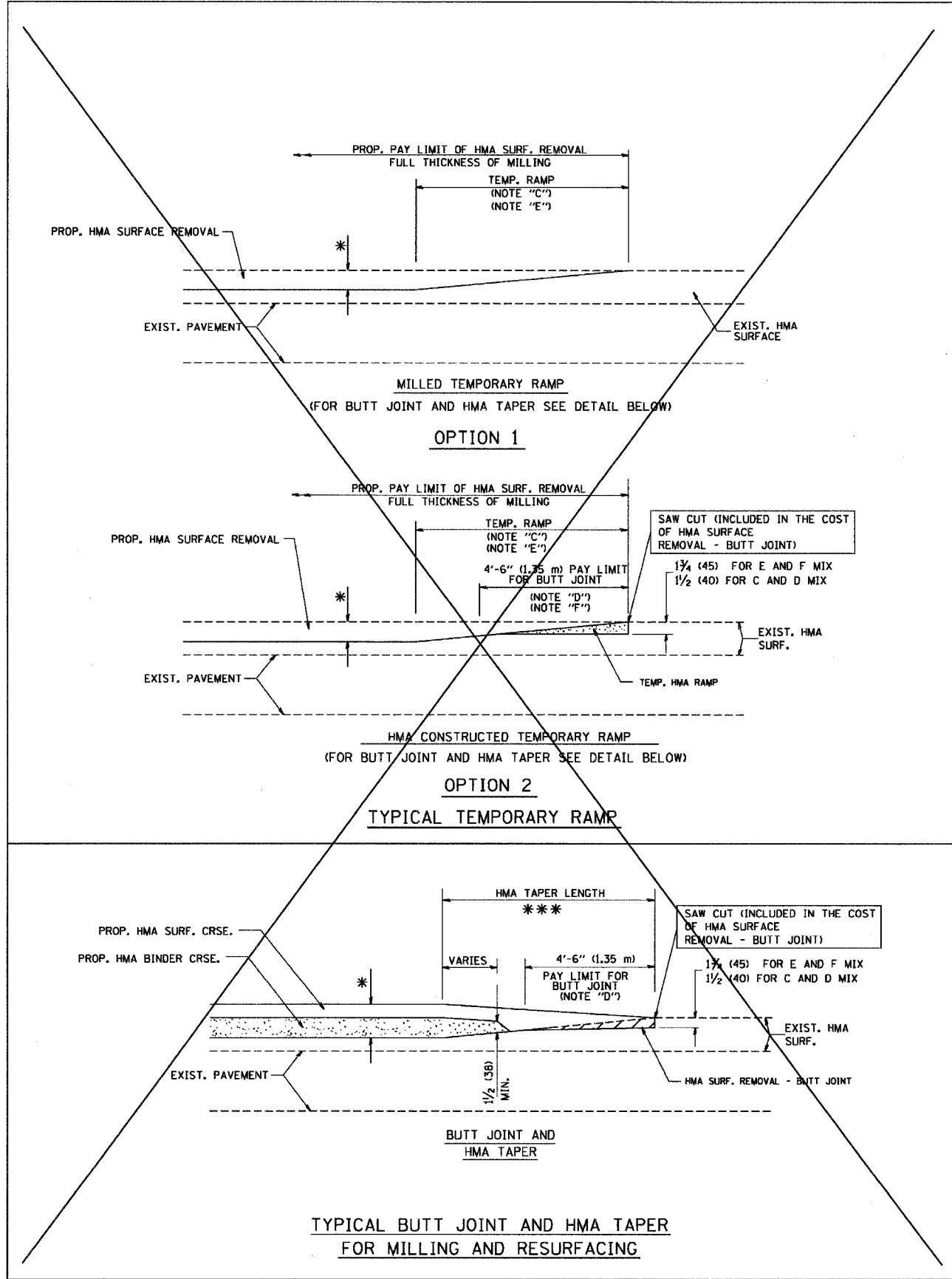

*** PC CONCRETE, HMA OR HMA RESURFACED PAVEMENT.

NOTES

- A: MAINLINE ROADWAYS AND MAJOR SIDE ROADS.
 - B: MINOR SIDE ROADS.
 - C: THE TEMP. RAMP SHALL BE CONSTRUCTED IMMEDIATELY UPON REMOVAL OF THE EXISTING HMA SURFACE.
 - D: THE BUTT JOINT SHALL BE CONSTRUCTED IMMEDIATELY PRIOR TO PLACING THE PROPOSED HMA COURSES.
 - E: TAPER THE TEMP. RAMP AT A RATE OF 3'-0" (900 mm) PER 1 INCH (25 mm) OF MILLING THICKNESS.
 - F: INSTALLATION AND REMOVAL OF THE 4'-6" (1.35 m) TEMP. RAMP IS INCLUDED IN COST OF HMA SURFACE REMOVAL - BUTT JOINT
 - G: SEE ARTICLE 406.08 AND 406.14 OF THE STANDARD SPECIFICATIONS FOR "HMA AND/OR PCC SURFACE REMOVAL, BUTT JOINT".
- * SEE TYPICAL SECTIONS FOR MILLING THICKNESS.
- *** 20'-0" (6.1 m) PER 1 (25) RESURFACING (NOTE "A")
 10'-0" (3.0 m) PER 1 (25) RESURFACING (NOTE "B")

BASIS OF PAYMENT:
 THE BUTT JOINT WILL BE PAID FOR AT THE CONTRACT UNIT PRICE PER SQUARE YARD (SQUARE METER) FOR "HOT-MIX ASPHALT SURFACE REMOVAL - BUTT JOINT" OR FOR "PORTLAND CEMENT CONCRETE SURFACE REMOVAL - BUTT JOINT".

ALL DIMENSIONS ARE IN INCHES (MILLIMETERS) UNLESS OTHERWISE SHOWN.

FILE NAME = W:\data\22x34\bd32.dgn	USER NAME = gagliemobt	DESIGNED - M. DE YONG	REVISED - R. SHAH 10-25-94
		DRAWN -	REVISED - A. ABBAS 03-21-97
		CHECKED -	REVISED - M. GOMEZ 04-06-01
		DATE - 06-13-90	REVISED - R. BORO 01-01-07

**STATE OF ILLINOIS
 DEPARTMENT OF TRANSPORTATION**

BUTT JOINT AND HMA TAPER DETAILS	
SCALE: NONE	SHEET NO. 1 OF 1 SHEETS STA. TO STA.

F.A. RTE.	SECTION	COUNTY	TOTAL SHEETS	SHEET NO.
	BD400-05 BD32			
FED. ROAD DIST. NO. 1		ILLINOIS FED. AID PROJECT		

FAU RTE. 2826-3601	SECTION *	COUNTY COOK	TOTAL SHEETS 16	SHEET NO. 16
STA. 48+50		TO STA. 53+46		
FED. ROAD DIST. NO.		ILLINOIS		
• 07-00071-00-RS				

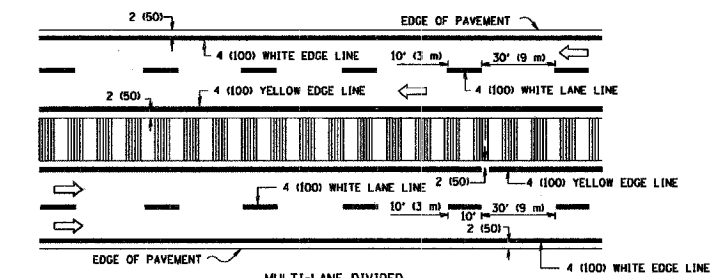
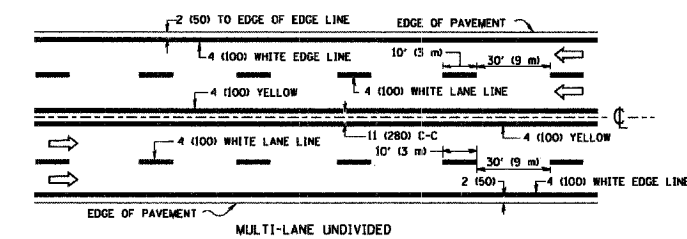
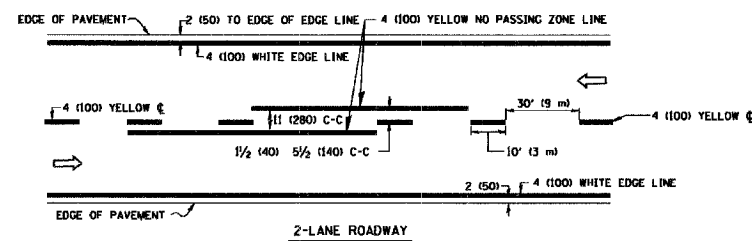

NOTE: MEDIANS WITH BARRIER CURB DO NOT REQUIRE AN EDGE LINE

TYPICAL LANE AND EDGE LINE MARKING

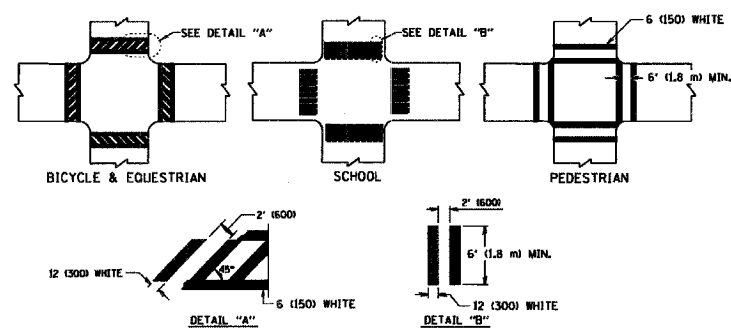

TYPICAL CROSSWALK MARKING

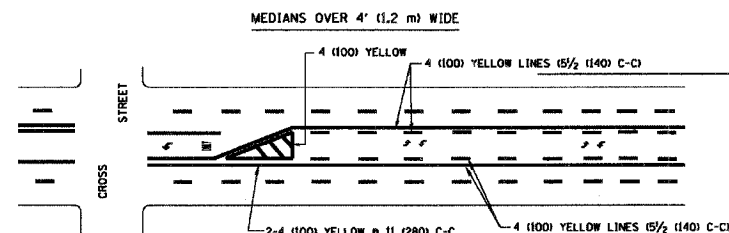
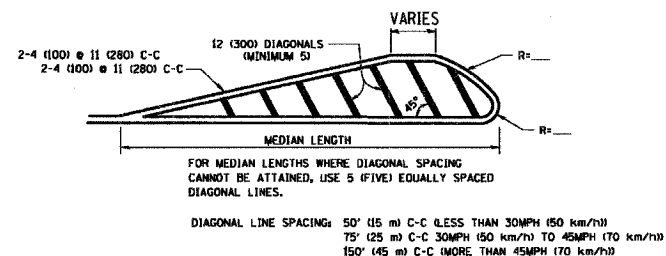
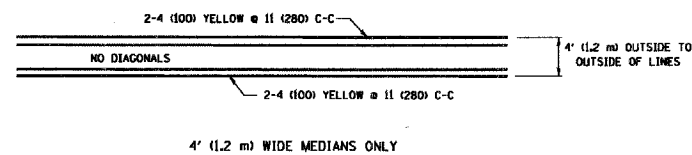

TYPICAL PAINTED MEDIAN MARKING

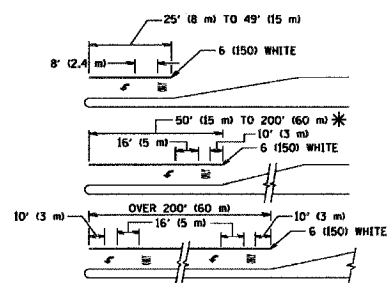

FULL SIZE LETTERS 8" (2.4 m) AND ARROWS SHALL BE USED.
 * TURN LANES IN EXCESS OF 400' (120 m) IN LENGTH MAY HAVE AN ADDITIONAL SET OF ARROW - "ONLY" INSTALLED MIDWAY BETWEEN THE OTHER TWO SETS OF ARROW - "ONLY".

TYPICAL LEFT (OR RIGHT) TURN LANE

TYPICAL TURN LANE MARKING

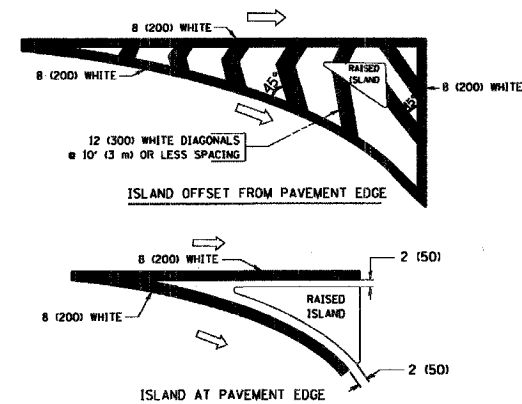

TYPICAL ISLAND MARKING

TYPE OF MARKING	WIDTH OF LINE	PATTERN	COLOR	SPACING / REMARKS
CENTERLINE ON 2 LANE PAVEMENT	4 (100)	SKIP-DASH	YELLOW	10' (3 m) LINE WITH 30' (9 m) SPACE
CENTERLINE ON MULTI-LANE UNDIVIDED PAVEMENT	2 @ 4 (100)	SOLID	YELLOW	11 (280) C-C
NO PASSING ZONE LINES FOR ONE DIRECTION FOR BOTH DIRECTIONS	4 (100) 2 @ 4 (100)	SOLID SOLID	YELLOW YELLOW	5/2 (140) C-C FROM SKIP-DASH CENTERLINE 11 (280) C-C ONLY SKIP-DASH CENTERLINE BETWEEN
LANE LINES	4 (100) 5 (125) ON FREEWAYS	SKIP-DASH SKIP-DASH	WHITE WHITE	10' (3 m) LINE WITH 30' (9 m) SPACE
DOTTED LINES (EXTENSIONS OF CENTER, LANE OR TURN LANE MARKINGS)	SAME AS LINE BEING EXTENDED	SKIP-DASH	SAME AS LINE BEING EXTENDED	2' (600) LINE WITH 6' (1.8 m) SPACE
EDGE LINES	4 (100)	SOLID	YELLOW-LEFT WHITE-RIGHT	OUTLINE MOUNTABLE MEDIANS IN YELLOW; EDGE LINES ARE NOT USED NEXT TO BARRIER CURB
TURN LANE MARKINGS	6 (150) LINE; FULL SIZE LETTERS & SYMBOLS (8" (2.4m))	SOLID	WHITE	SEE TYPICAL TURN LANE MARKING DETAIL
TWO WAY LEFT TURN MARKING	2 @ 4 (100) EACH DIRECTION 8' (2.4m) LEFT ARROW	SKIP-DASH AND SOLID IN PAIRS	YELLOW WHITE	10' (3 m) LINE WITH 30' (9 m) SPACE FOR SKIP-DASH; 5/2 (140) C-C BETWEEN SOLID LINE AND SKIP-DASH LINE SEE TYPICAL TWO-WAY LEFT TURN MARKING DETAIL
CROSSWALK LINES (PEDESTRIAN A. DIAGONALS (BIKE & EQUESTRIAN) B. LONGITUDINAL BARS (SCHOOL))	2 @ 6 (150) 12 (300) @ 45° 12 (300) @ 90°	SOLID SOLID SOLID	WHITE WHITE WHITE	NOT LESS THAN 6' (1.8 m) APART 2' (600) APART SEE TYPICAL CROSSWALK MARKING DETAILS.
STOP LINES	24 (600)	SOLID	WHITE	PLACE 4' (1.2 m) IN ADVANCE OF AND PARALLEL TO CROSSWALK, IF PRESENT. OTHERWISE, PLACE AT DESIRED STOPPING POINT. PARALLEL TO CROSSROAD CENTERLINE, WHERE POSSIBLE
PAINTED MEDIANS	2 @ 4 (100) WITH 12 (300) DIAGONALS @ 45° NO DIAGONALS USED FOR 4' (1.2 m) WIDE MEDIANS	SOLID	YELLOW; TWO WAY TRAFFIC WHITE; ONE WAY TRAFFIC	11 (280) C-C FOR THE DOUBLE LINE SEE TYPICAL PAINTED MEDIAN MARKING.
CORE MARKING AND CHANNELIZING LINES	8 (200) WITH 12 (300) DIAGONALS @ 45°	SOLID	WHITE	DIAGONALS: 15' (4.5 m) C-C (LESS THAN 30MPH (50 km/h)) 20' (6 m) C-C 30MPH (50 km/h) TO 45MPH (70 km/h) 30' (9 m) C-C (OVER 45MPH (70 km/h))
RAILROAD CROSSING	24 (600) TRANSVERSE LINES; "RR" 15 6" (1.8 m) LETTERS; 16 (400) LINE FOR "X"	SOLID	WHITE	SEE STATE STANDARD 780001 AREA OF: "R"-3.6 SQ. FT. (10.33 m ²) EACH "X"-34.0 SQ. FT. (5.0 m ²)
SHOULDER DIAGONALS	12 (300) @ 45°	SOLID	WHITE - RIGHT YELLOW - LEFT	50' (15 m) C-C (LESS THAN 30MPH (50 km/h)) 75' (25 m) C-C (30 MPH (50 km/h) TO 45MPH (70 km/h)) 150' (45 m) C-C (OVER 45MPH (70 km/h))

FOR FURTHER DETAILS ON PAVEMENT MARKING REFER TO STANDARD SPECIFICATIONS FOR ROAD AND BRIDGE CONSTRUCTION AND STATE STANDARD 780001.

All dimensions are in inches (millimeters) unless otherwise shown.

FILE NAME M:\projects\22234\1\c13.dgn	USER NAME gagliardi	DESIGNED EVERS	REVISED -T. RAMMACHER 10-27-94
PLOT SCALE = 3/8" = 1' IN.	CHECKED -A. HOUSEH 10-17-96	DRAWN -	REVISED -A. HOUSEH 10-09-96
PLOT DATE = 1/4/2008	DATE = 03-19-90		REVISED -T. RAMMACHER 01-06-00

**STATE OF ILLINOIS
DEPARTMENT OF TRANSPORTATION**

DISTRICT ONE TYPICAL PAVEMENT MARKINGS			
SCALE: NONE	SHEET NO. 1 OF 1 SHEETS	STA.	TO STA.

SECTION TC-13	COUNTY ILLINOIS	TOTAL SHEETS 16	SHEET NO. 16
CONTRACT NO.		FED. ROAD DIST. NO. 1 ILLINOIS FED. AID PROJECT	