

ELEVATION

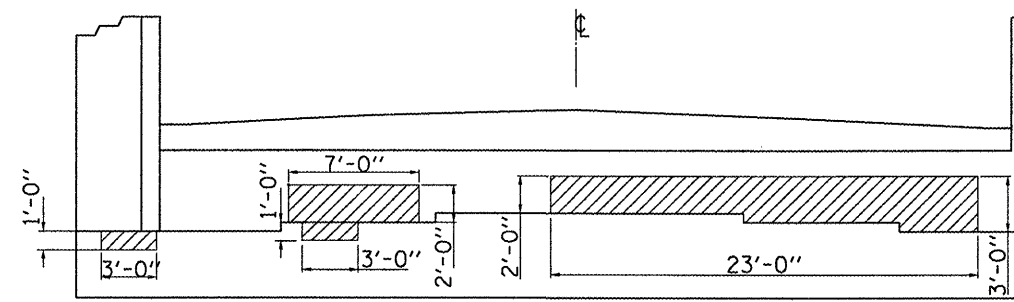

ELEVATION

NOTE:

DIMENSIONS SHOWN ARE APPROXIMATE, THE ENGINEER SHALL SOUND THE REPAIR AREAS AS SHOWN TO DETERMINE EXACT LIMITS OF STRUCTURAL REPAIR OF CONCRETE.

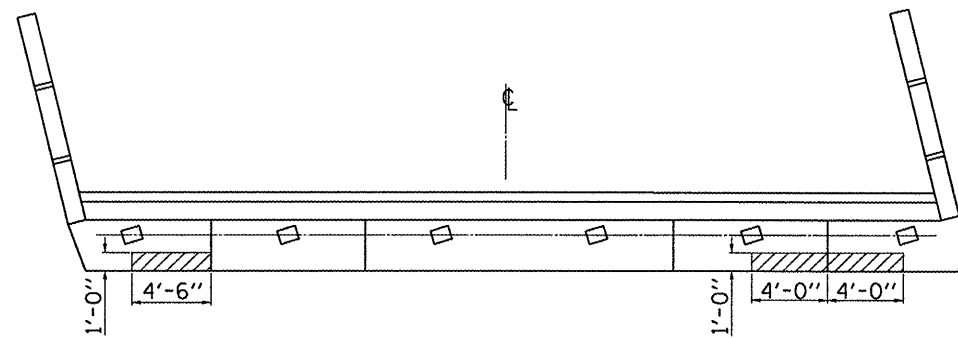

PLAN

NORTH ABUTMENT

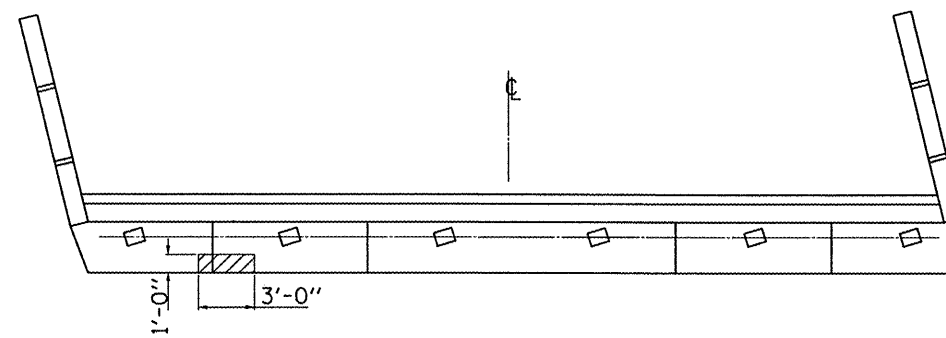

PLAN

SOUTH ABUTMENT

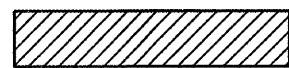

STRUCTURAL REPAIR OF CONCRETE
(DEPTH EQUAL TO OR LESS THAN 5")

BILL OF MATERIAL

ITEM	UNIT	TOTAL
STRUCTURAL REPAIR OF CONCRETE (DEPTH EQUAL TO OR LESS THAN 5")	SQ FT	190

FILE NAME =	USER NAME = woodshankr1	DESIGNED - RON WOODSHANK	REVISED - 03/21/2008
c:\projects\cm305\cm305\deta11s.dgn		DRAWN - RON WOODSHANK	REVISED - 03/21/2008
PLOT SCALE = 41.3612' / IN.		CHECKED -	REVISED -
PLOT DATE = Apr 02, 2008 - 11:03:20 AM		DATE -	REVISED -

STATE OF ILLINOIS
DEPARTMENT OF TRANSPORTATION

STRUCTURAL REPAIR OF CONCRETE

SCALE: SHEET NO. 2 OF 3 SHEETS STA. 571+00.67 TO STA. 573+01.17

F.A.P. RTE. 846	SECTION 66B-1J1	COUNTY GRUNDY	TOTAL SHEETS 29	SHEET NO. 27
CONTRACT NO. 66728				FED. ROAD DIST. NO. ILLINOIS FED. AID PROJECT