

MATERIAL: CAST GRAY IRON ASTM A-48,
CLASS 35B
FINISH: NC PAINT
WEIGHT: 167 (76)

GENERAL NOTES

- NEENAH R-4808-A TYPE P GRATE OR EQUIVALENT SHALL BE USED.
- NEENAH R-3210-AL FRAME OR EQUIVALENT SHALL BE USED WITH THIS GRATE.
- THIS WORK SHALL BE PERFORMED IN ACCORDANCE WITH SECTION 602 OF THE STANDARD SPECIFICATIONS.
- THIS WORK WILL BE PAID FOR AT THE CONTRACT UNIT PRICE EACH FOR INLETS TO BE ADJUSTED WITH NEW FRAME AND GRATE (SPECIAL).

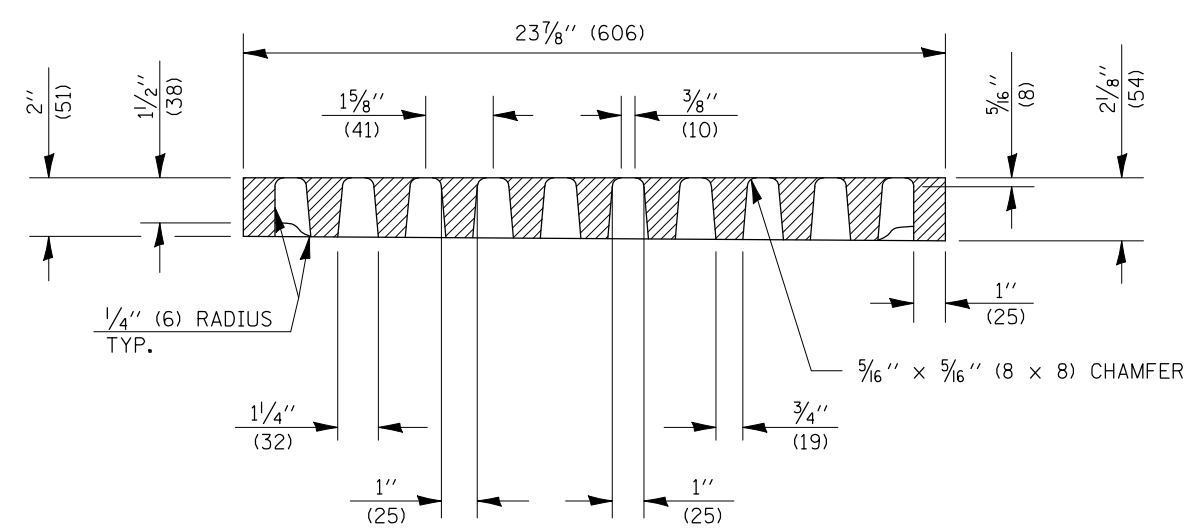

Note: All dimensions are in INCHES (millimeters) unless otherwise shown.

DISTRICT 5 DETAIL NO. 60262510

FILE NAME =	USER NAME = craige	DESIGNED -	REVISED - 11/06
ct:\projects\d503606 (v8)\70516-details.dgn		DRAWN -	REVISED -
	PLOT SCALE = 40.0000 ' / IN.	CHECKED -	REVISED -
	PLOT DATE = 3/25/2008	DATE -	REVISED -

**STATE OF ILLINOIS
DEPARTMENT OF TRANSPORTATION**

INLETS TO BE ADJUSTED WNEW FRAME AND GRATE (SPECIAL)

SCALE:	SHEET NO.	OF	SHEETS	STA.	TO	STA.
--------	-----------	----	--------	------	----	------

F.A.P. RTE.	SECTION	COUNTY	TOTAL SHEETS	SHEET NO.
730	(56)RS-2	MCLEAN	51	35
CONTRACT NO. 70516				
FED. ROAD DIST. NO. ILLINOIS FED. AID PROJECT				