

FAU ROUTE	SECTION	COUNTY	TOTAL SHEETS	SHEET NO.
8071	*	SANGAMON	425	283
STA. TO STA.		ILLINOIS FED. AID PROJECT		
FED. ROAD DIST. NO.		(84-9) RS-6; (G)Z *		

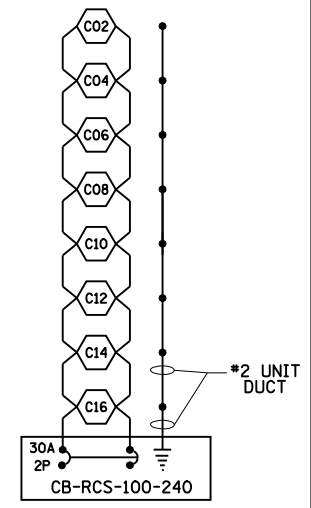

CONTROLLER 1 CKT A
ALL *4 UNIT DUCT UNLESS OTHERWISE NOTED

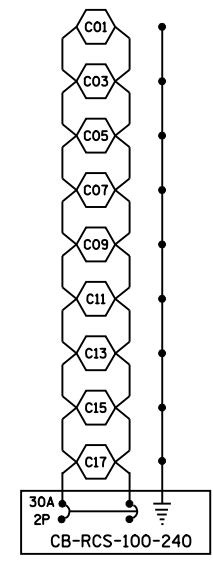

CONTROLLER 1 CKT B
ALL *2 UNIT DUCT

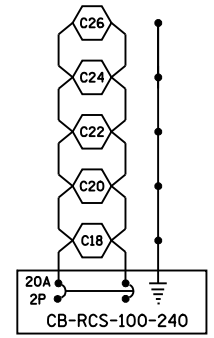

CONTROLLER 1 CKT D
ALL *6 UNIT DUCT

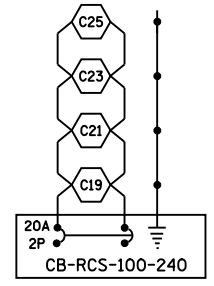

CONTROLLER 1 CKT C
ALL *8 UNIT DUCT

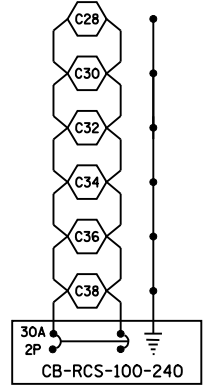

CONTROLLER 2 CKT A
ALL *6 UNIT DUCT

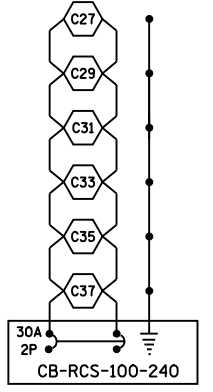

CONTROLLER 2 CKT B
ALL *6 UNIT DUCT

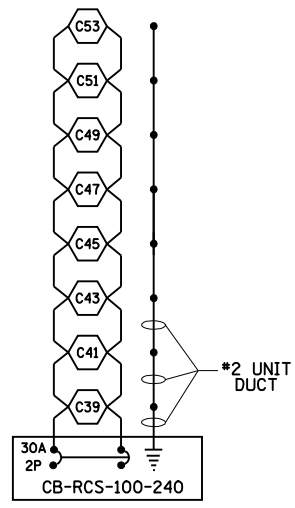

CONTROLLER 2 CKT C
ALL *4 UNIT DUCT UNLESS OTHERWISE NOTED

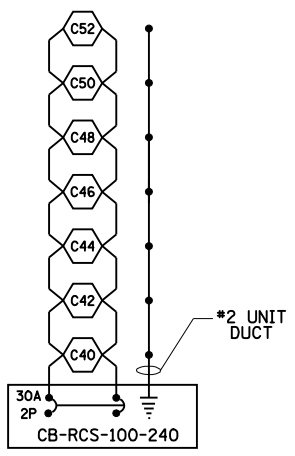

CONTROLLER 2 CKT D
ALL *4 UNIT DUCT UNLESS OTHERWISE NOTED

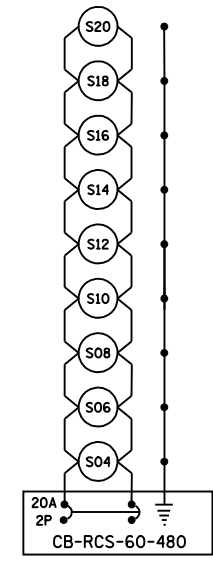

CONTROLLER 3 CKT A
ALL *8 UNIT DUCT

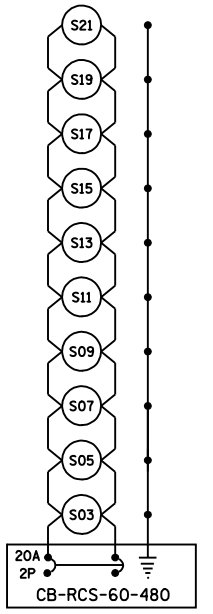

CONTROLLER 3 CKT B
ALL *8 UNIT DUCT

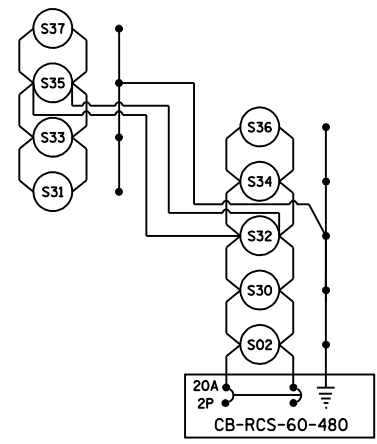

CONTROLLER 3 CKT C
ALL *8 UNIT DUCT

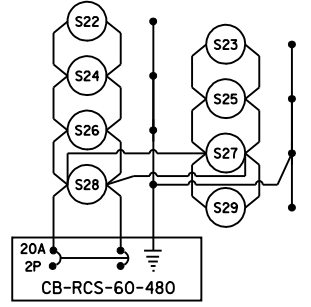

CONTROLLER 3 CKT D
ALL *8 UNIT DUCT

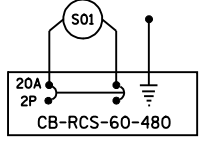

CONTROLLER 3 CKT E
ALL *8 UNIT DUCT

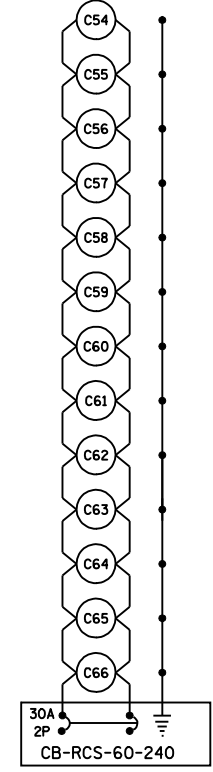

CONTROLLER 4 CKT A
ALL *2 UNIT DUCT

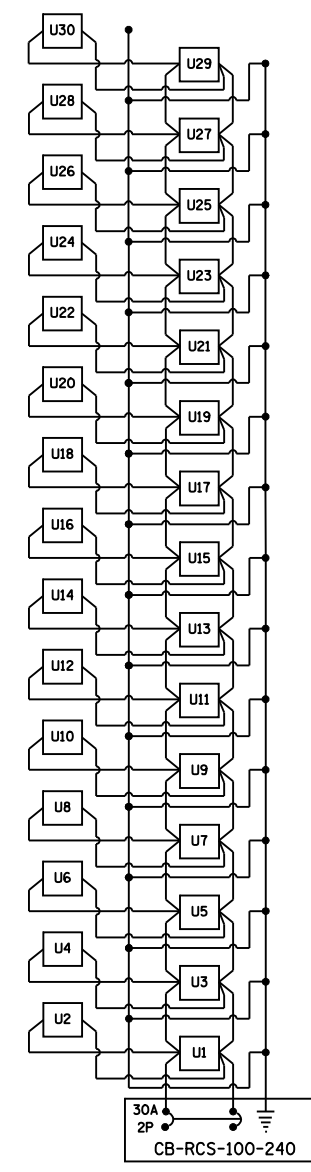

CONTROLLER 2 CKT E
ALL *4 UNIT DUCT

- LEGEND**
- 400 WATT HPS FIXTURE
 - 250 WATT HPS FIXTURE
 - EXISTING PEDESTRIAN UNDERPASS LUMINAIRE 70 WATT

REVISIONS	
NAME	DATE

ILLINOIS DEPARTMENT OF TRANSPORTATION
LIGHTING DETAILS -1
 MACARTHUR BOULVARD SECTION
 (84-9) RS-6; (G)Z
 SANGAMON COUNTY, ILLINOIS

SCALE: VERT. HORIZ. DATE: Apr-30-2008 01:57:31PM

DRAWN BY: JAP
 CHECKED BY: JWM