

F.A. RTE.	SECTION	COUNTY	TOTAL SHEETS	SHEET NO.
•	••	SANGAMON	425	393

STA.	TO STA.
FED. ROAD DIST. NO. - ILLINOIS	FED. AID PROJECT

- FAI 72 (I-72) AND FAU 8071 (MACARTHUR BOULEVARD)
- SECTION (84-9) RS-6; (G)Z

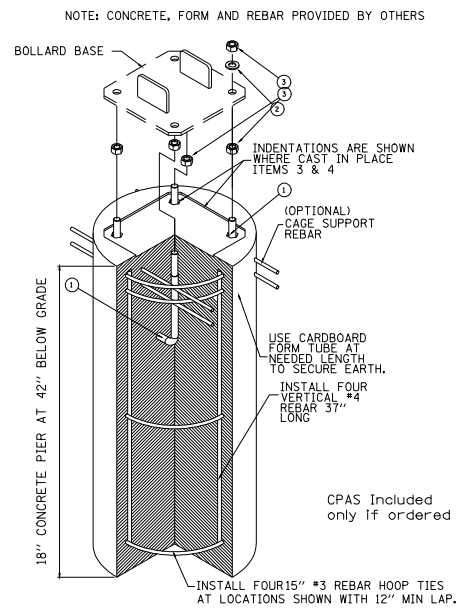
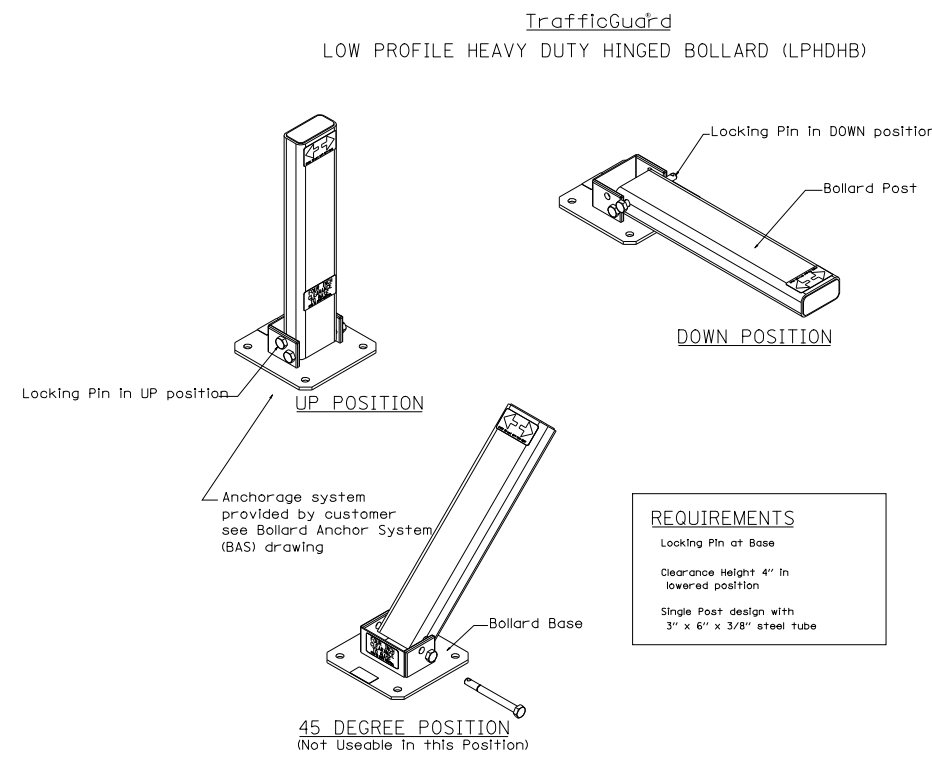

CONCRETE PIER ANCHOR SYSTEM FOR DROP GATE

DROP GATE SPECIFICATIONS

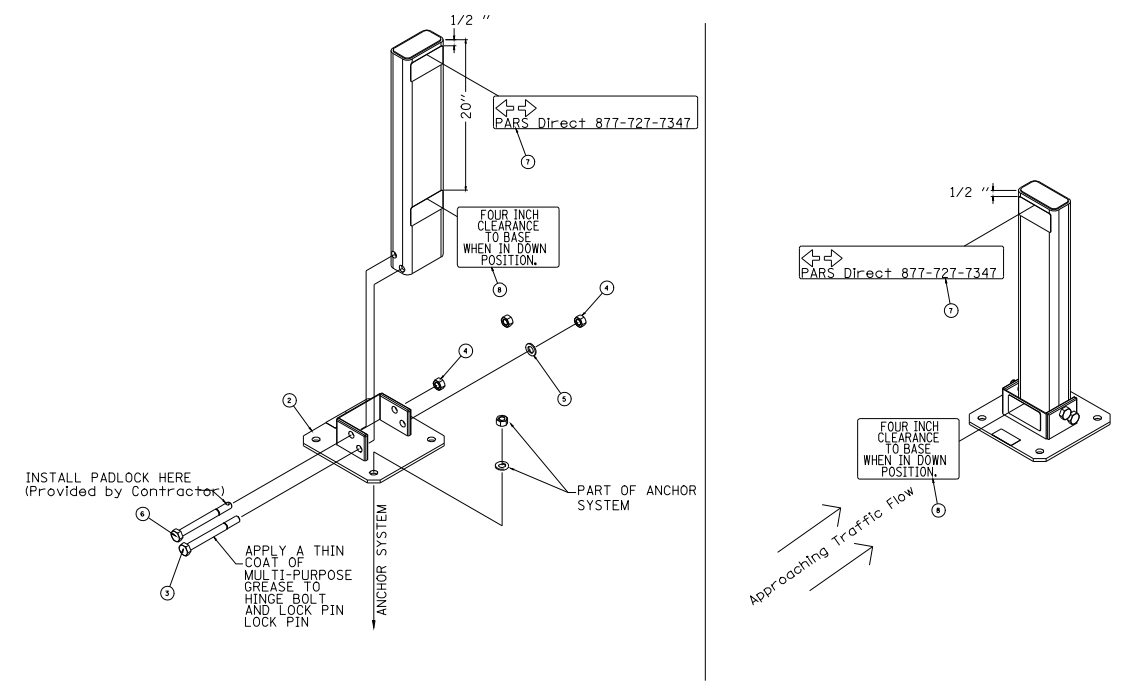

DROP GATE INSTALLATION DETAIL

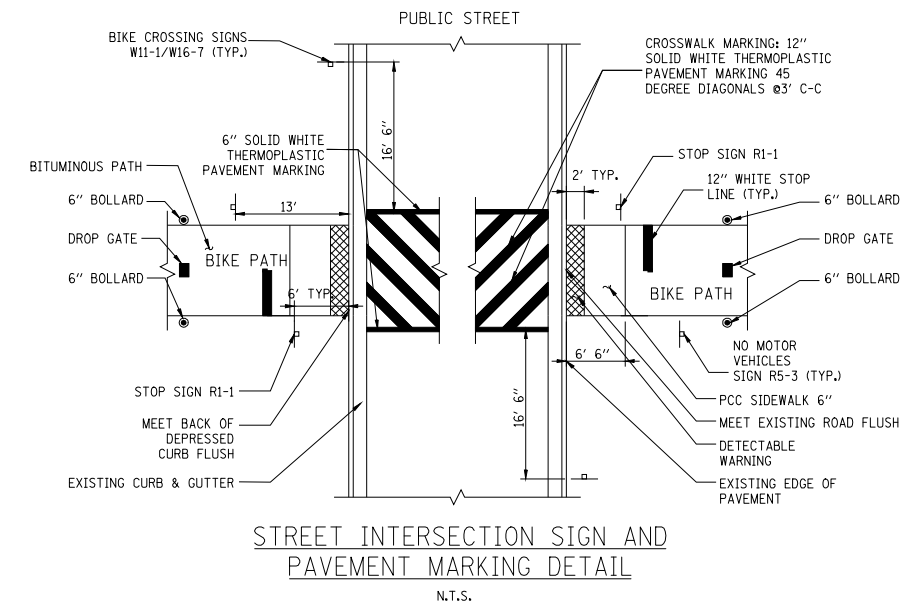

STREET INTERSECTION SIGN AND PAVEMENT MARKING DETAIL

SHIVE HATTERY
Cedar Rapids, IA \ Iowa City, IA \ Des Moines, IA
Moline, IL \ Bloomington, IL \ Chicago, IL
SHIVE-HATTERY, INC. 228 BAYLAND DRIVE BLOOMINGTON, ILLINOIS 62506
PHONE (309) 663-8888 FAX (309) 663-8888
http://www.shive-hattery.com
ILLINOIS PERM. WORKER 38-00054

REVISIONS	
NAME	DATE

ILLINOIS DEPARTMENT OF TRANSPORTATION
LEGACY POINTE SHARED USE PATH
STREET CROSSING DETAIL

SCALE: VERT. NONE
HORIZ. NONE
DATE: 9/08

DRAWN BY: JAB
CHECKED BY: DWS

PLOT DATE = Mar-09-2008 15:44:50AM
 PLOT NAME = C:\Projects\6865007\shive-hattery.dwg
 PLOT SCALE = 1:1
 USER NAME = jhughes