

GREENBRIAR DR

GREENBRIAR DR

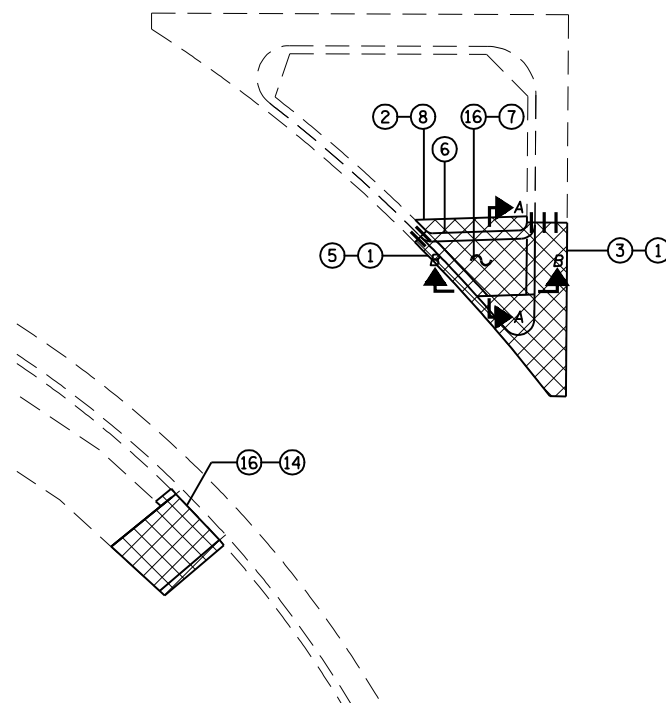

SB IL 4

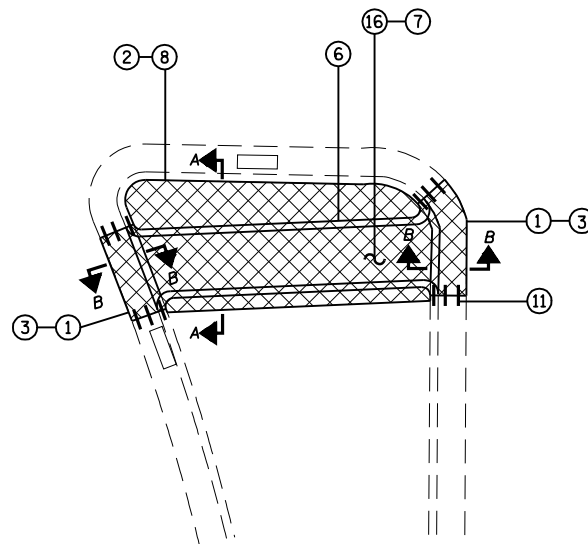

NB IL 4

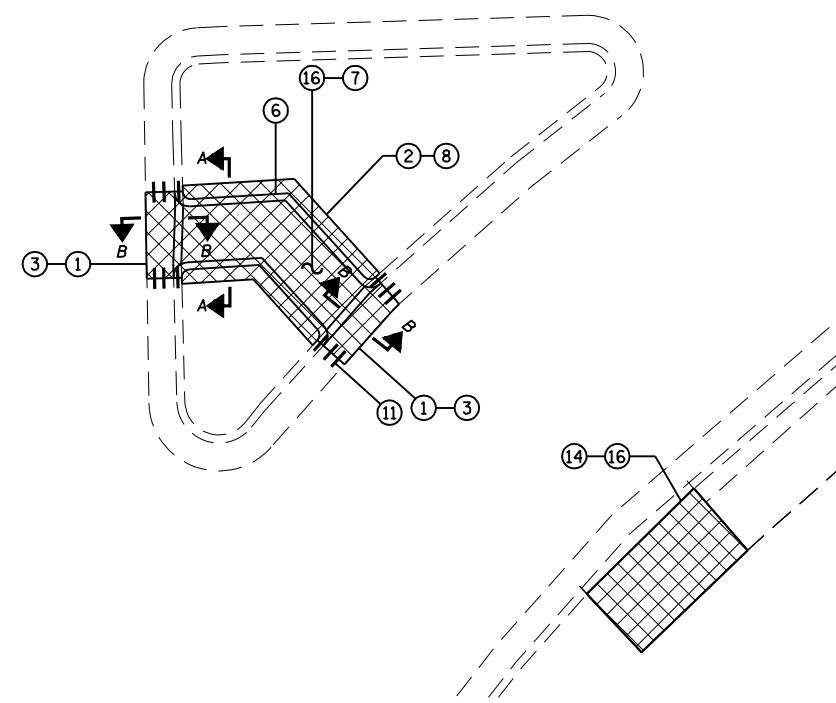

GREENBRIAR DR SIDEWALK PLAN

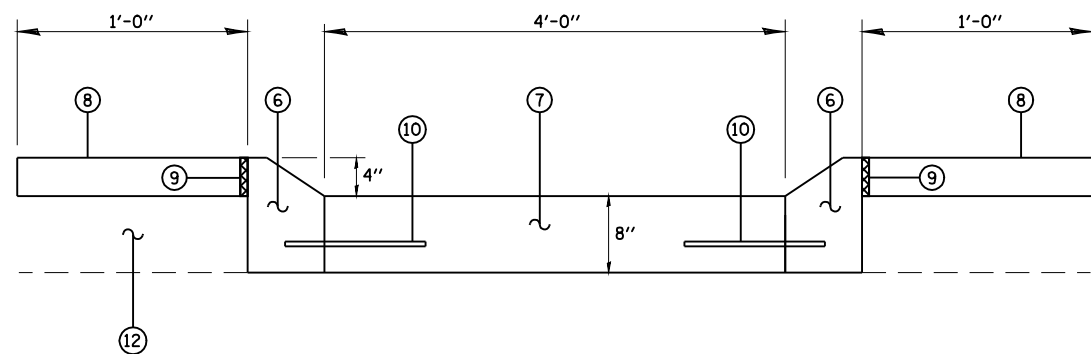

SECTION A-A

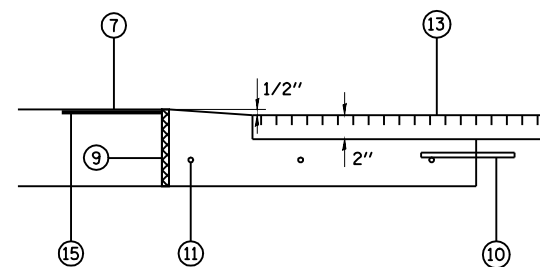

SECTION B-B

LEGEND

- ① EXIST. COMBINATION CURB AND GUTTER TBR
 - ② EXIST. 4" CONCRETE MEDIAN SURFACE TBR
 - ③ PROP. COMBINATION CURB AND GUTTER TYPE M-6.24
 - ④ PROP. COMBINATION CURB AND GUTTER TYPE B-6.24
 - ⑤ PROP. COMBINATION CURB AND GUTTER TYPE M-6.06
 - ⑥ PROP. CONCRETE CURB TYPE M (SPECIAL)
 - ⑦ PROP. P.C.C. SIDEWALK 8"
 - ⑧ PROP. CONCRETE MEDIAN SURFACE 4"
 - ⑨ PROP. 3/4" PREFORMED EXPANSION JOINT FILLER (TYP.)
 - ⑩ PROP. TIE BAR
 - ⑪ PROP. DOWEL BAR
 - ⑫ PROP. SUB BASE GRANULAR MATERIAL MATERIAL TYPE B
 - ⑬ PROP. HMA RESURFACING
 - ⑭ PROP. P.C.C. SIDEWALK 4"
 - ⑮ PROP. DETECTABLE WARNINGS
 - ⑯ SIDEWALK REMOVAL
 - Ⓗ REBUILD EXISTING SIDEWALKS
- ▨ INDICATES PCC SURFACE REMOVAL-BUTT JOINT OR HOT-MIX ASPHALT SURFACE REMOVAL-BUTT JOINT

NOTE:

1. FOR ADDITIONAL INFORMATION ABOUT CURB AND GUTTER, MEDIAN AND SIDEWALK SEE STD. 424001, 606001, & 606301
2. UNLESS OTHERWISE SHOWN ALL RADII ARE 1'

CUMMINS ENGINEERING CORPORATION

| | |
|----------|--------------------|
| JOB | - 2200 |
| FILE | - sht-details4.dgn |
| DESIGNED | - NAK |
| DRAWN | - AJH |
| CHECKED | - NAK |
| DATE | - 3/15/2008 |

| | |
|-----------|-----------|
| REVISIONS | REVISIONS |
| REVISIONS | REVISIONS |
| REVISIONS | REVISIONS |
| REVISIONS | REVISIONS |

STATE OF ILLINOIS
DEPARTMENT OF TRANSPORTATION

CROSSWALK & ISLAND DETAILS

SCALE: SHEET NO. OF SHEETS STA. TO STA.

| F.A.P. RTE. | SECTION | COUNTY | TOTAL SHEETS | SHEET NO. |
|---------------------|-------------------------------|----------|---------------------------|-----------|
| 662 | 2-2(RS) & 3-1, 2(RS-10, TS-5) | SANGAMON | 181 | 120 |
| FED. ROAD DIST. NO. | | | ILLINOIS FED. AID PROJECT | |
| | | | CONTRACT NO. 72889 | |

| | |
|---|------------------------|
| FILE NAME = | USER NAME = laughlinr1 |
| C:\Projects\d652204\cummins_final\d67289-sht-details4.dgn | |
| PLOT SCALE = 40.0000' / IN. | |
| PLOT DATE = Mar-18-2008 11:43:02AM | |