

(TYPICAL) PROPOSED LONGITUDINAL JOINT REPAIR DETAIL

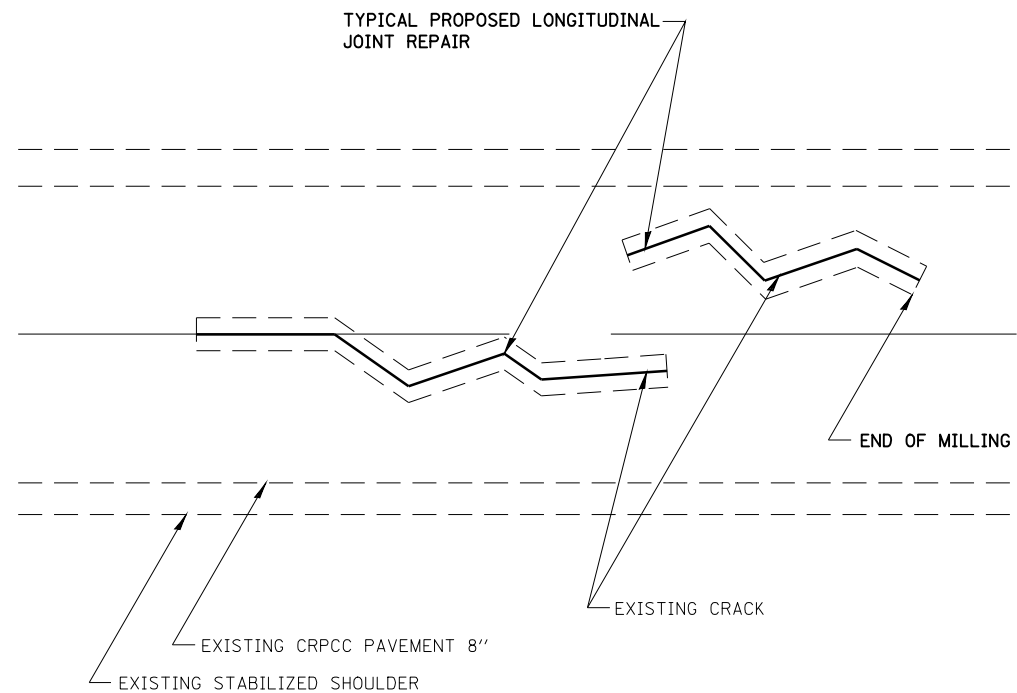

PROPOSED LONGITUDINAL JOINT REPAIR PLAN VIEW

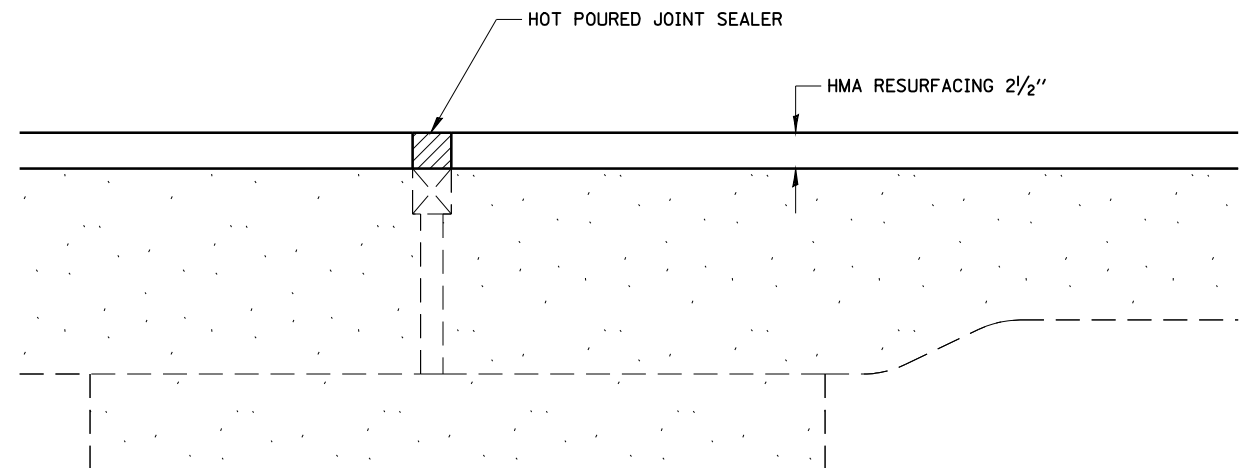

PREFORMED JOINT SEAL TREATMENT SECTION A-A (AT PREFORMED JOINT)

NOTE:

CONTRACTOR TO SURFACE OVER EXISTING PREFORMED JOINT SEALER. UPON COMPLETION OF RESURFACING, CONTRACTOR IS TO SAW CUT AT THE EDGE OF THE PJS AND REMOVE THE BITUMINOUS MATERIAL, COST TO BE INCLUDED WITH HMA RESURFACING ITEMS.

CONTRACTOR TO PLACE HOT POURED JOINT SEALER PER STANDARD SPECIFICATION 1050.02 OVER PJS, COST TO BE INCLUDED IN HMA RESURFACING ITEMS.

CONTRACTOR IS TO NOTE LOCATION OF PREFORMED JOINT SEAL PRIOR TO RESURFACING TO ALLOW EDGES TO BE IDENTIFIED FOR SAW CUT LOCATION.

CUMMINS ENGINEERING CORPORATION		JOB - 2200	
FILE NAME =	USER NAME = laughlinr1	FILE - sht-details3.dgn	
C:\Projects\d652204\cummins_final\d67289-sht-details3.dgn		DESIGNED - NAK	REVISED -
		DRAWN - AJH	REVISED -
		CHECKED - NAK	REVISED -
		DATE - 3/15/2008	REVISED -
	PLOT SCALE = 100.0000' / IN.		
	PLOT DATE = Mar-18-2008 11:43:13AM		

**STATE OF ILLINOIS
DEPARTMENT OF TRANSPORTATION**

**LONGITUDINAL JOINT REPAIR
PREFORMED JOINT SEAL TREATMENT**

SCALE: SHEET NO. OF SHEETS STA. TO STA.

F.A.P. RTE.	SECTION	COUNTY	TOTAL SHEETS	SHEET NO.
662	2-2(RS) & 3-1, 2(RS-10, TS-5)	SANGAMON	181	125
CONTRACT NO. 72889				
FED. ROAD DIST. NO.		ILLINOIS FED. AID PROJECT		