

STATE OF ILLINOIS
 DEPARTMENT OF TRANSPORTATION
 DIVISION OF HIGHWAYS
**PROPOSED
 HIGHWAY PLANS**

FOR INDEX OF SHEETS, SEE SHEET NO. 2

F.A.I. ROUTE 72
 SECTION (58,74)(66,67)RS-1
 PROJECT: IM-072-1(073)150
 MACON COUNTY
 C-97-082-06

F.A.I. RTE.	SECTION	COUNTY	TOTAL SHEETS	SHEET NO.
72	(58,74)(66,67)RS-1	MACON	88	1
FED. ROAD DIST. NO.	ILLINOIS	CONTRACT NO. 74171		

D-97-044-06

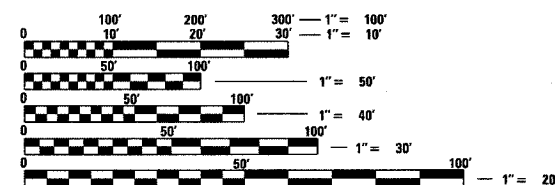
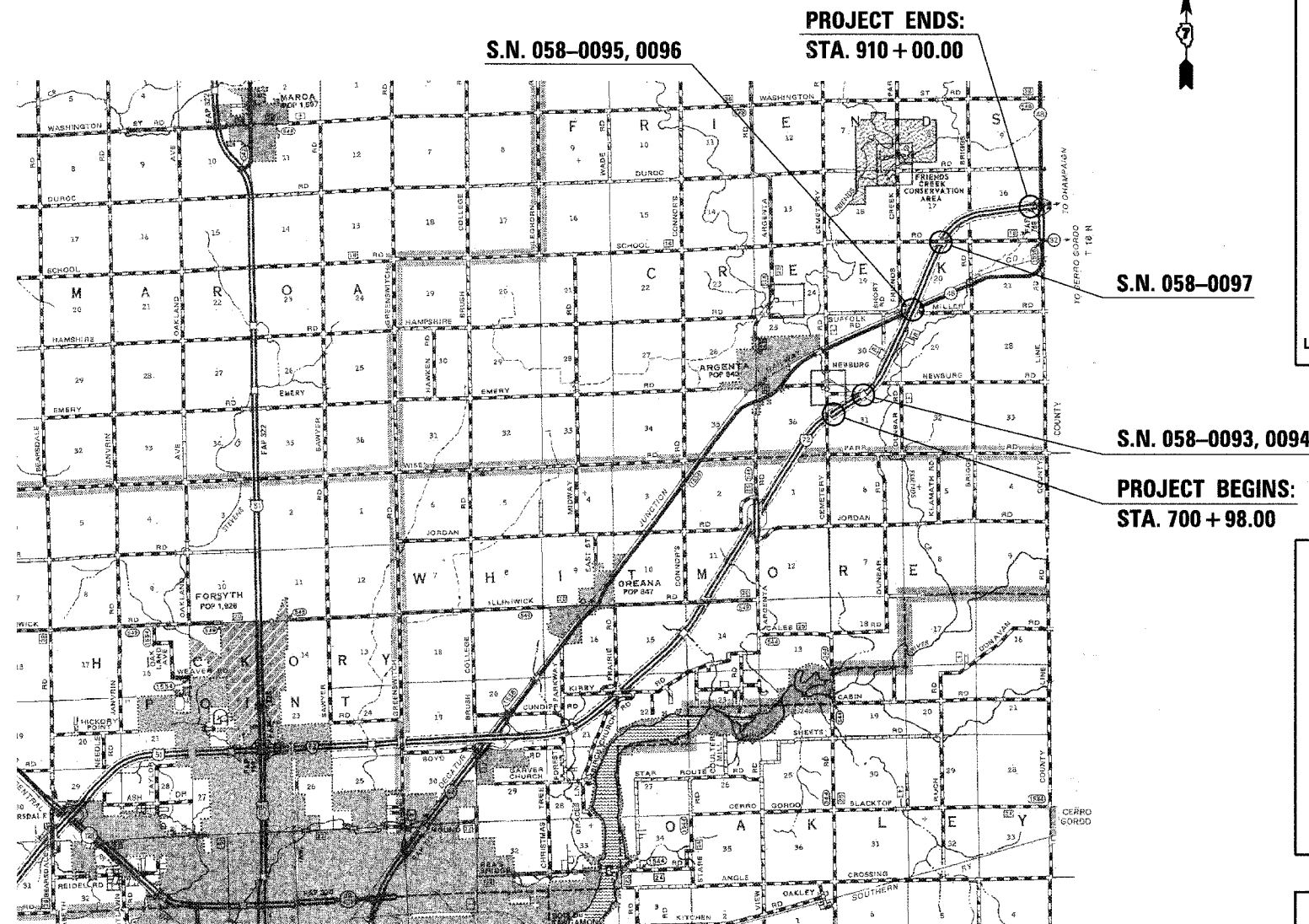

FULL SIZE PLANS HAVE BEEN PREPARED USING STANDARD ENGINEERING SCALES. REDUCED SIZED PLANS WILL NOT CONFORM TO STANDARD SCALES. IN MAKING MEASUREMENTS ON REDUCED PLANS, THE ABOVE SCALES MAY BE USED.

J.U.L.I.E.
 JOINT UTILITY LOCATION INFORMATION FOR EXCAVATION
 1-800-892-0123
 OR 811

TOWNSHIP: FRIENDS CREEK
 PROJECT ENGINEER - TOM RONAN
 PROJECT MANAGER - JEFF DAVISON
 ADT = 10,533
 CONTRACT NO. 74171

GROSS LENGTH = 20,902 FT. = 3.96 MI.
 NET LENGTH = 20,902 FT. = 3.96 MI.

STATE OF ILLINOIS
 DEPARTMENT OF TRANSPORTATION
 DIVISION OF HIGHWAYS

SUBMITTED March 21, 2008
Christina M. Reed
 DEPUTY DIRECTOR OF HIGHWAYS, REGION ENGINEER

May 9, 2008
Eric E. Harrel
 INTERIM ENGINEER OF DESIGN AND ENVIRONMENT

May 9, 2008
Christina M. Reed
 DIRECTOR OF HIGHWAYS, CHIEF ENGINEER

PRINTED BY THE AUTHORITY
 OF THE STATE OF ILLINOIS

INDEX OF SHEETS

1	COVER SHEET
2	INDEX OF SHEETS & STANDARDS
3	GENERAL NOTES
4-5	SUMMARY OF QUANTITIES
6-8	TYPICAL SECTIONS
9-16	SCHEDULE OF QUANTITIES
17-25	ROADWAY PLAN SHEETS
26-77	BRIDGE REPAIR PLANS
78	PAVEMENT MARKING DETAILS
79-82	DETAIL SHEETS
83-88	CROSS SECTION SHEETS

STANDARDS IN THE PLANS

000001-05	STANDARD SYMBOLS, ABBREVIATIONS AND PATTERNS
001001-01	AREAS OF REINFORCEMENT BARS
001006	DECIMAL OF AN INCH AND OF A FOOT
420401-06	BRIDGE APPROACH PAVEMENT
442001-04	CLASS A PATCHES
442006-07	CLASS B PATCHES
442201-03	CLASS C AND D PATCHES
482006-03	HMA SHOULDER ADJACENT TO RIGID PAVEMENT
601001-02	SUB-SURFACE DRAINS
601101	CONCRETE HEADWALL FOR PIPE DRAIN
630001-07	STEEL PLATE BEAM GUARDRAIL
630301-04	SHOULDER WIDENING FOR TYPE 1 (SPECIAL) GUARDRAIL TERMINALS
631031-06	TRAFFIC BARRIER TERMINAL, TYPE 6
635001	DELINEATORS
635006-02	REFLECTOR AND TERMINAL MARKER PLACEMENT
635011-01	REFLECTOR MARKER AND MOUNTING DETAILS
642001	SHOULDER RUMBLE STRIPS
701101-01	OFF-ROAD OPERATIONS, MULTILANE, 4.5m (15*) TO 600mm (24*)
701316-03	LANE CLOSURE, 2L, 2W, BRIDGE REPAIR FOR SPEEDS >45 MPH
701400-02	APPROACH TO LANE CLOSURE, FREEWAY/EXPRESSWAY
701401-04	LANE CLOSURE, FREEWAY/EXPRESSWAY
701402-06	LANE CLOSURE, FREEWAY/EXPRESSWAY WITH BARRIER
701406-04	LANE CLOSURE, FREEWAY/EXPRESSWAY, DAY OPERATIONS ONLY
701411-04	LANE CLOSURE, MULTILANE, AT ENTRANCE OR EXIT RAMP FOR SPEEDS >45 MPH
701426-02	LANE CLOSURE, MULTILANE, INTERMITTENT OR MOVING OPERATIONS FOR SPEEDS >45 MPH
701901	TRAFFIC CONTROL DEVICES
704001-04	TEMPORARY CONCRETE BARRIER

FILE NAME = c:\projects\74171d\shindex.74171.dgn	USER NAME = swartzw	DESIGNED -	REVISED -	STATE OF ILLINOIS DEPARTMENT OF TRANSPORTATION	INDEX OF SHEETS & GENERAL NOTES	F.A.I RTE. 72	SECTION (58,74)(66,67)RS-1	COUNTY MACON	TOTAL SHEETS 88	SH N
	PLOT SCALE = 20.0000' / IN.	CHECKED -	REVISED -		SCALE: NA	SHEET NO. OF SHEETS STA. TO STA.		CONTRACT NO. 741		
	PLOT DATE = 3/28/2008	DATE -	REVISED -				FED. ROAD DIST. NO.		ILLINOIS FED. AID PROJECT	

GENERAL NOTES

THIS SECTION SHALL BE CONSTRUCTED IN ACCORDANCE WITH THE PLANS, THE "STANDARD SPECIFICATIONS FOR ROAD AND BRIDGE CONSTRUCTION", ADOPTED JANUARY 1, 2007; THE "SUPPLEMENTAL SPECIFICATIONS AND RECURRING SPECIAL PROVISIONS" INDICATED ON THE CHECK SHEET, AND "THE SPECIAL PROVISIONS" INCLUDED IN THE PROPOSAL.

THE WORK IN SECTION (58,74)(66,67)RS-1 INCLUDES PATCHING AND RESURFACING THE EXISTING PAVEMENT, AGGREGATE AND BITUMINOUS SHOULDERS, AND OTHER WORK NECESSARY TO COMPLETE THIS SECTION.

PLAN DIMENSIONS AND DETAILS RELATIVE TO THE EXISTING STRUCTURE HAVE BEEN TAKEN FROM EXISTING PLANS AND ARE SUBJECT TO NOMINAL CONSTRUCTION VARIATIONS. IT SHALL BE THE CONTRACTOR RESPONSIBILITY TO VERIFY SUCH DIMENSIONS AND DETAILS IN THE FIELD AND MAKE NECESSARY APPROVED ADJUSTMENTS PRIOR TO THE CONSTRUCTION OR ORDERING OF MATERIAL. SUCH VARIATIONS SHALL NOT BE CAUSE FOR ADDITIONAL COMPENSATION OR A CHANGE IN THE SCOPE OF THE WORK. THE CONTRACTOR WILL BE PAID FOR THE QUANTITY ACTUALLY FURNISHED AT THE UNIT PRICE BID FOR THE WORK.

THE PROPOSED PROJECT BEGINS APPROXIMATELY 1.8 MILES EAST OF ARGENTA AND EXTENDS IN AN EASTERLY DIRECTION A DISTANCE OF 3.80 MILES.

SHORT TERM PAVEMENT MARKING ON THE MILLED SURFACE SHALL BE PAINT. ALL OTHER SHORT TERM PAVEMENT MARKINGS SHALL BE TAPE.

THE QUANTITIES ALLOWED FOR MIXTURE FOR CRACKS, JOINTS AND FLANGEWAYS AND PAVEMENT PATCHING ARE ESTIMATES. THE ACTUAL LOCATIONS AND QUANTITIES SHALL BE DETERMINED BY THE ENGINEER IN THE FIELD.

ALL ELEVATIONS SHOWN IN PLANS ARE BASED ON U. S. G. S. DATUM.

ALL DISTURBED AREAS WITHIN THE CONSTRUCTION LIMITS SHALL BE FERTILIZED AND SEEDED. SEEDING SHALL BE CLASS 2 (SPECIAL) IN ACCORDANCE WITH THE SPECIAL PROVISIONS AND THE APPLICABLE ARTICLES OF SECTION 250 OF THE STANDARD SPECIFICATIONS.

THE PAVEMENT SHALL BE CLEANED IN ACCORDANCE WITH SECTION 406 OF THE STANDARD SPECIFICATIONS PRIOR TO THE PLACING OF THE BITUMINOUS OVERLAYS. AREAS TO BE PREPARED SHALL BE DETERMINED BY THE ENGINEER AND WILL INCLUDE:

1. BROKEN OR DELAMINATED CONCRETE
2. PATCHES OF TAR OR COLD MIX
3. EXISTING UNSTABLE PATCHES
4. DETERIORATED AREAS BEYOND EXISTING PATCHES
5. CENTERLINE JOINT

THE CONTRACTOR SHALL PROVIDE INTERNET ACCESS TO THE BITUMINOUS PLANT QUALITY CONTROL LAB SO THAT BITUMINOUS PLANT REPORTS CAN BE E-MAILED TO THE DISTRICT HEADQUARTERS. THIS WORK WILL NOT BE PAID FOR SEPARATELY BUT SHALL BE INCLUDED IN THE UNIT PRICES FOR OTHER ITEMS IN THE CONTRACT.

IN ADDITIONAL TO THE REQUIREMENTS FOR PORTABLE CHANGEABLE MESSAGE SIGNS IN ARTICLE 701.15(I), A LAPTOP COMPUTER SHALL ALSO BE SUPPLIED BY THE CONTRACTOR.

BASE COURSE WIDENING SHALL INCLUDE ALL EXCAVATION FOR CONSTRUCTION OF THE WIDENING. THE WIDENING SHALL, AT THE CONTRACTOR'S OPTION BE CONSTRUCTED OF EITHER PORTLAND CEMENT CONCRETE 8" THICK, OR HOT-MIX ASPHALT, 10" THICK. THE WIDENING SHALL REMAIN IN PLACE AT THE CONCLUSION OF THE JOB.

THE RESIDENT ENGINEER SHALL BE THE SOLE JUDGE CONCERNING THE CURING TIME FOR THE BITUMINOUS SURFACE COURSE.

BITUMINOUS MATERIALS (PRIME COAT) SHALL BE EITHER RC-70 OR SS-1HP.

AGGREGATE FOR AGGREGATE SHOULDERS ON INTERSTATE ROUTES SHALL BE CRUSHED STONE, CRUSHED CONCRETE, OR RAP.

COST OF REMOVAL OF TEMPORARY RAMP SHALL BE INCLUDED IN THE UNIT PRICE FOR TEMPORARY RAMP.

THE FOLLOWING MIXTURE REQUIREMENTS ARE APPLICABLE TO THIS PROJECT:

APPLICATION	AC/PG	DESIGN AIR VOIDS	MIXTURE COMPOSITION	FRICTION AGGREGATE
BINDER COURSE (2**)				
POLYMERIZED HOT MIX ASPHALT BINDER COURSE, IL-19.0, N105	SBS PG 70-22	4.0% @ N=105	IL-19.0	N/A
SURFACE COURSE & CROSS OVERS (1**)				
POLYMERIZED HOT MIX ASPHALT SURFACE COURSE, MIX *D*, N105	SBS PG 70-22	4.0% @ N=105	IL-9.5	MIXTURE D
HMA SHOULDERS (1**)				
HOT MIX ASPHALT SHOULDERS	PG 58-22	2.0% @ N=30	IL-9.5	N/A
PARTIAL DEPTH PATCHING				
HOT MIX ASPHALT BINDER COURSE, SUPERPAVE IL-19.0, N90	PG 64-22	4.0% @ N=105	IL-19.0	N/A
SHOULDER MIX (WIDENING)				
HOT MIX ASPHALT BINDER COURSE, SUPERPAVE IL-19.0, N90	PG 64-22	4.0% @ N=90	IL-19.0	N/A

ONCE THE FINAL SURFACE MIX IS PLACED ON THE HOT MIX ASPHALT SHOULDERS, THE LOCATIONS OF THE PIPE UNDERDRAIN OUTLETS SHALL BE RE-ESTABLISHED WITH A *T* PAINTED ON THE OUTSIDE EDGE OF THE SHOULDERS. THE COST OF RE-ESTABLISHING THE OUTLET LOCATIONS SHALL BE CONSIDERED INCLUDED IN THE COST OF THE PAVEMENT MARKING.

THE TYPE E AND TYPE F SHOULDER INLETS FROM STATIONS LT. 707+50 TO LT. 718+19.60 AND FROM STATION RT. 715+00 TO RT. 718+82.60, SHALL BE PROTECTED FROM STAGE TRAFFIC IN A MANNER APPROVED BY THE ENGINEER.

FILE NAME = c:\projects\74171d\shindex_74171.dgn	USER NAME = swartzw	DESIGNED -	REVISED -	STATE OF ILLINOIS DEPARTMENT OF TRANSPORTATION	INDEX OF SHEETS & GENERAL NOTES	F.A.I. RTE. 72	SECTION (58,74)(66,67)RS-1	COUNTY MACON	TOTAL SHEETS 88	SHEET NO. 3
	PLOT SCALE = 20,000' / 1" IN.	CHECKED -	REVISED -		SCALE: NA	SHEET NO.	OF	SHEETS	STA.	TO STA.
	PLOT DATE = 3/25/2006	DATE -	REVISED -							
						FED. ROAD DIST. NO. ILLINOIS FED. AID PROJECT				

SUMMARY OF QUANTITIES				CONSTRUCTION TYPE CODES					
				FAI 72 ROADWAY 4 LANE 90% FED 10% STATE	FAI 72 BRIDGE SN 058-0093 90% FED 10% STATE	FAI 72 BRIDGE SN 058-0094 90% FED 10% STATE	FAI 72 BRIDGE SN 058-0095 90% FED 10% STATE	FAI 72 BRIDGE SN 058-0096 90% FED 10% STATE	FAI 72 BRIDGE SN 058-0097 90% FED 10% STATE
CODE NO	ITEM	UNIT	TOTAL QUANTITIES	I000	X031-2A	X031-2A	X531-2A	X531-2A	X231-2A
20200100	EARTH EXCAVATION	CU YD	1232	1232					
25001000	SEEDING, CLASS 2 (SPECIAL)	ACRE	0.81	0.81					
25100115	MULCH, METHOD 2	ACRE	0.81	0.81					
28000250	TEMPORARY EROSION CONTROL SEEDING	POUND	81	81					
31100300	SUB-BASE GRANULAR MATERIAL, TYPE A 4"	SQ YD	4013	4013					
35650500	BASE COURSE WIDENING 10"	SQ YD	174	174					
40600100	BITUMINOUS MATERIALS (PRIME COAT)	GALLON	19053	19053					
40600300	AGGREGATE (PRIME COAT)	TON	380	380					
40600895	CONSTRUCTING TEST STRIP	EACH	1	1					
40600982	HOT-MIX ASPHALT SURFACE REMOVAL - BUTT JOINT	SQ YD	44	44					
40600985	PORTLAND CEMENT CONCRETE SURFACE REMOVAL - BUTT JOINT	SQ YD	71	71					
40600990	TEMPORARY RAMP	SQ YD	1733	1733					
40603245	POLYMERIZED HOT-MIX ASPHALT BINDER COURSE, 1L-19.0, N105	TON	13890	13890					
40603550	POLYMERIZED HOT-MIX ASPHALT SURFACE COURSE, MIX "D", N105	TON	9541	9541					
42001165	BRIDGE APPROACH PAVEMENT	SQ YD	203	203					
44213100	PAVEMENT FABRIC	SQ YD	18	18					
42001430	BRIDGE APPROACH PAVEMENT CONNECTOR (FLEXIBLE)	SQ YD	129	129					
44000100	PAVEMENT REMOVAL	SQ YD	163	163					
44000153	HOT-MIX ASPHALT SURFACE REMOVAL, 1"	SQ YD	55146	55146					
44000155	HOT-MIX ASPHALT SURFACE REMOVAL, 1 1/2"	SQ YD	960	960					
44000162	HOT-MIX ASPHALT SURFACE REMOVAL, 3 1/4"	SQ YD	115402	115402					
44000198	HOT-MIX ASPHALT SURFACE REMOVAL, VARIABLE DEPTH	SQ YD	17883	17883					
44000915	HOT-MIX ASPHALT SURFACE REMOVAL (DECK)	SQ YD	7400		1740	1749	1506	1506	899
44004250	PAVED SHOULDER REMOVAL	SQ YD	3333	3333					
44200525	CLASS A PATCHES, TYPE I, 8 INCH	SQ YD	429	429					
44200529	CLASS A PATCHES, TYPE II, 8 INCH	SQ YD	558	558					
44200533	CLASS A PATCHES, TYPE III, 8 INCH	SQ YD	107	107					
44200535	CLASS A PATCHES, TYPE IV, 8 INCH	SQ YD	137	137					
44200559	CLASS A PATCHES, TYPE IV, 10 INCH	SQ YD	2240	2240					
44200934	CLASS B PATCHES, TYPE II, 8 INCH	SQ YD	41	41					
44200942	CLASS B PATCHES, TYPE III, 8 INCH	SQ YD	18	18					
44201741	CLASS D PATCHES, TYPE II, 8 INCH	SQ YD	85	85					
44213000	PATCHING REINFORCEMENT	SQ YD	3471	3471					
44213200	SAW CUTS	FOOT	10466	10466					
48101200	AGGREGATE SHOULDERS, TYPE B	TON	1352	1352					
48203043	HOT-MIX ASPHALT SHOULDERS, 11 1/2"	SQ YD	3406	3406					
48203100	HOT-MIX ASPHALT SHOULDERS	TON	5992	5992					
50102400	CONCRETE REMOVAL	CU YD	137.7		11.6	11.6	49.2	53.3	12
50157300	PROTECTIVE SHIELD	SQ YD	3284				1124	1124	1036
50300100	FLOOR DRAINS	EACH	156		30	30	40	40	16
50300255	CONCRETE SUPERSTRUCTURE	CU YD	155.9		13.8	14.1	55.3	59.4	13.3
50300260	BRIDGE DECK GROOVING	SQ YD	7400		1740	1749	1506	1506	899
50300300	PROTECTIVE COAT	SQ YD	7603	203	1740	1749	1506	1506	899
50500405	FURNISHING AND ERECTING STRUCTURAL STEEL	POUND	10030		2355	2355	1710	1710	1900
50500715	JACK AND REMOVE EXISTING BEARINGS	EACH	56		12	12	12	12	8
50800205	REINFORCEMENT BARS, EPOXY COATED	POUND	24110		3490	3530	7040	7040	3010
50800515	BAR SPLICERS	EACH	224		28	28	72	72	24
51500200	RELOCATING NAME PLATES	EACH	2				1	1	
52000110	PREFORMED JOINT STRIP SEAL	FOOT	658		96	96	192	192	82

FILE NAME = c:\projects\74171\d\shstsq.74171.dgn	USER NAME = swartzu	DESIGNED - JLD	REVISED -	STATE OF ILLINOIS DEPARTMENT OF TRANSPORTATION	SUMMARY OF QUANTITIES (1 OF 2)			F.A.I RTE.	SECTION	COUNTY	TOTAL SHEETS	SHEET NO.	
		DRAWN - RWS	REVISED -		SCALE: NA	SHEET NO. 1 OF 2 SHEETS	STA.	TO STA.	72	(58,74)(66,67)RS-1	MACON	88	4
		CHECKED - WES	REVISED -		CONTRACT NO. 74171								
		DATE - 10-07	REVISED -		ILLINOIS FED. AID PROJECT								

EXISTING TYPICAL CROSS SECTION

STA. 700+98 TO STA. 910+00

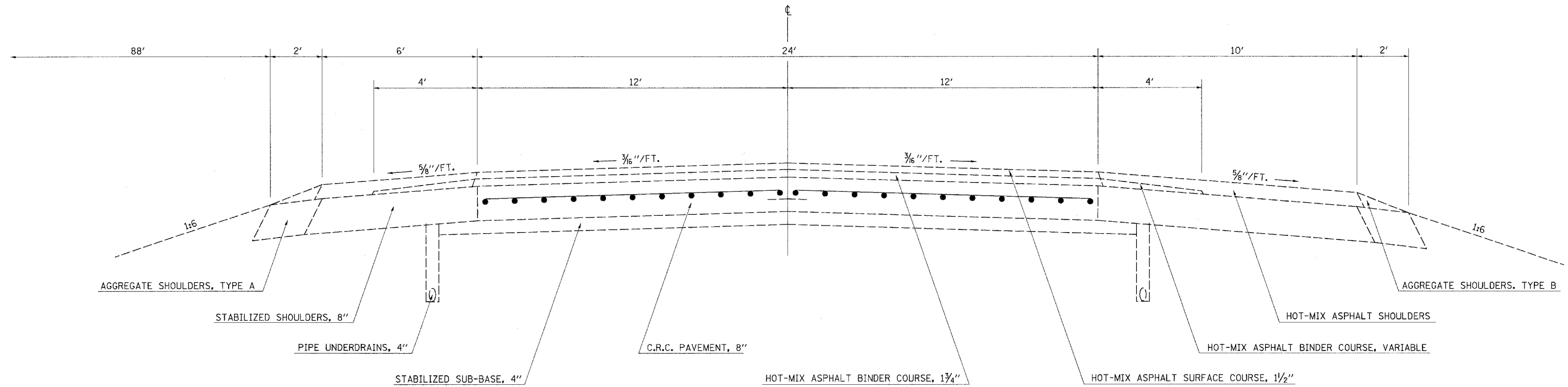

EXISTING SHOULDER DETAIL

RT. STA. 715+00 TO RT. STA. 718+82.60
 LT. STA. 707+50 TO LT. STA. 718+19.60

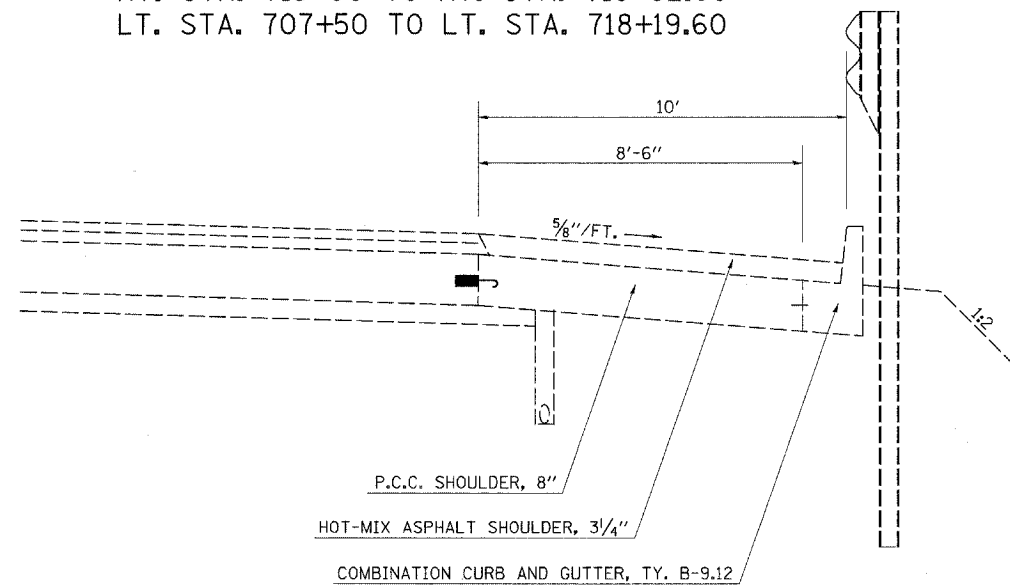

SHOULDER DETAIL

RT. STA. 711+00 TO RT. STA. 715+00

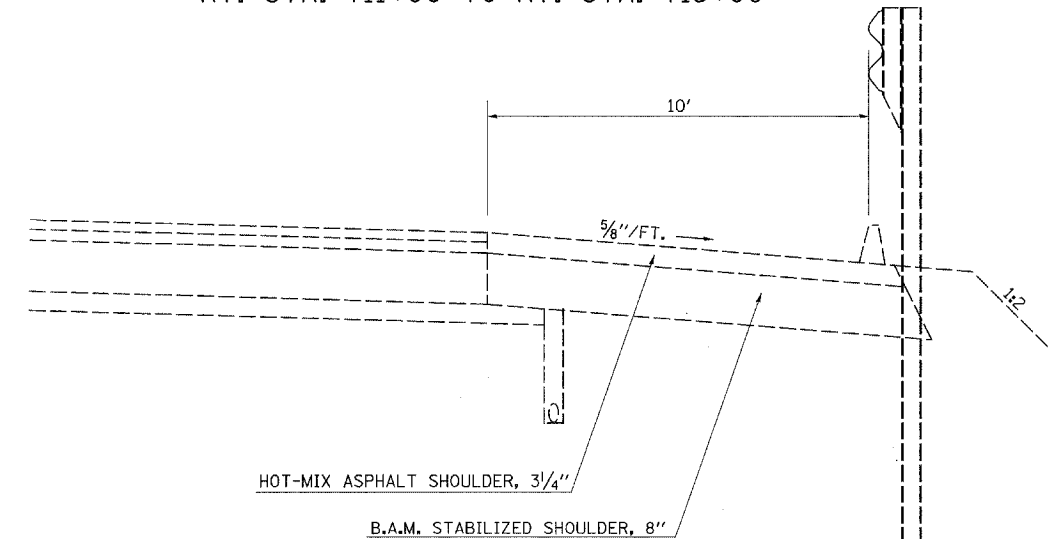

FILE NAME = c:\projects\74171d\hsttypicals.74171.dgn	USER NAME = swartzw	DESIGNED -	REVISED -
		DRAWN -	REVISED -
	PLOT SCALE = 20.0000' / IN.	CHECKED -	REVISED -
	PLOT DATE = 3/29/2008	DATE -	REVISED -

**STATE OF ILLINOIS
 DEPARTMENT OF TRANSPORTATION**

TYPICAL CROSS SECTIONS

SCALE: NA SHEET NO. 1 OF 3 SHEETS STA. TO STA.

F.A.I. RTE. 72	SECTION (58,74)(66,67)RS-1	COUNTY MACON	TOTAL SHEETS 88	SH. N.
FED. ROAD DIST. NO. ILLINOIS FED. AID PROJECT				CONTRACT NO. 741

EXISTING TYPICAL CROSS SECTION

REST AREA RAMPS

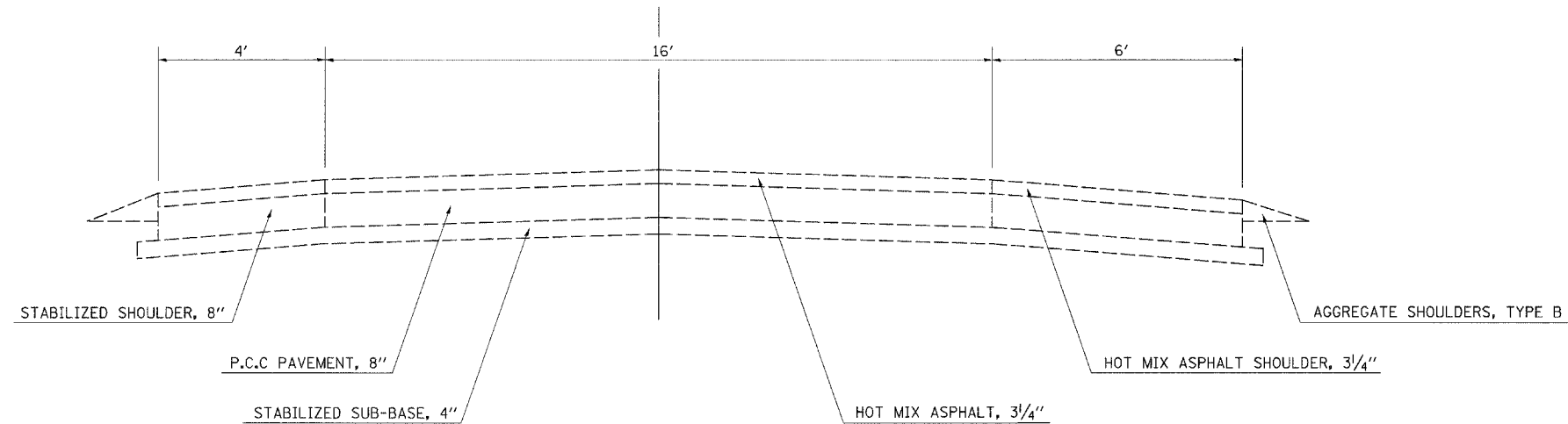

PROPOSED TYPICAL CROSS SECTION

REST AREA RAMPS

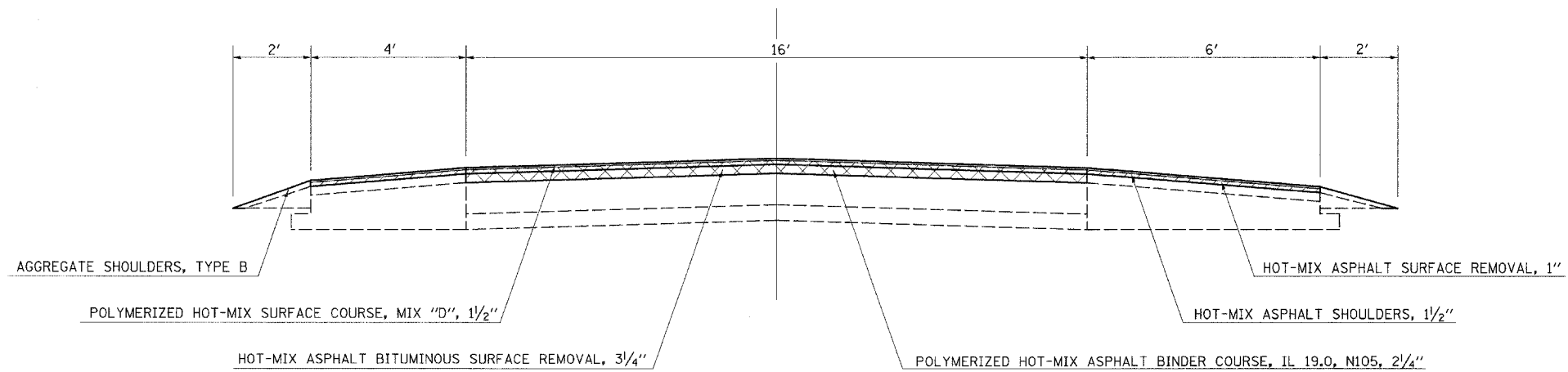

FILE NAME =	USER NAME = swartzrw	DESIGNED -	REVISED -
c:\projects\74171\d\shittypicals_74171.dgn		DRAWN -	REVISED -
		CHECKED -	REVISED -
		DATE -	REVISED -

**STATE OF ILLINOIS
DEPARTMENT OF TRANSPORTATION**

SCALE: NA	SHEET NO. 2 OF 3 SHEETS	STA.	TO STA.
-----------	-------------------------	------	---------

F.A.I RTE.	SECTION	COUNTY	TOTAL SHEETS	SHE NO.
72	(58,74)(66,67)RS-1	MACON	88	7
CONTRACT NO. 741				
FED. ROAD DIST. NO.	ILLINOIS FED. AID PROJECT			

PROPOSED TYPICAL CROSS SECTION

STA. 700+98 TO STA. 910+00

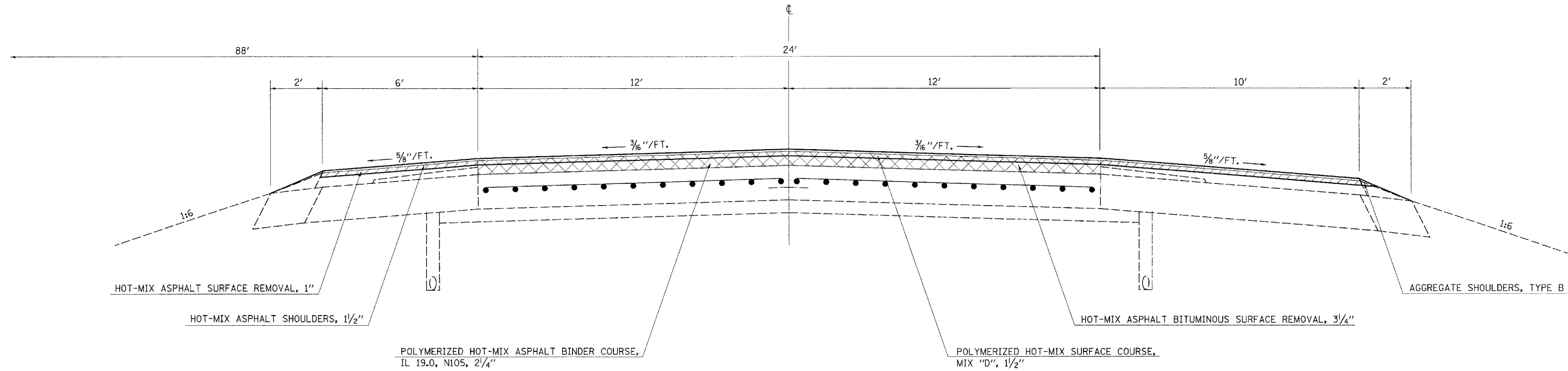

SHOULDER DETAIL

RT. STA. 715+00 TO RT. STA. 718+82.60
 LT. STA. 707+50 TO LT. STA. 718+19.60

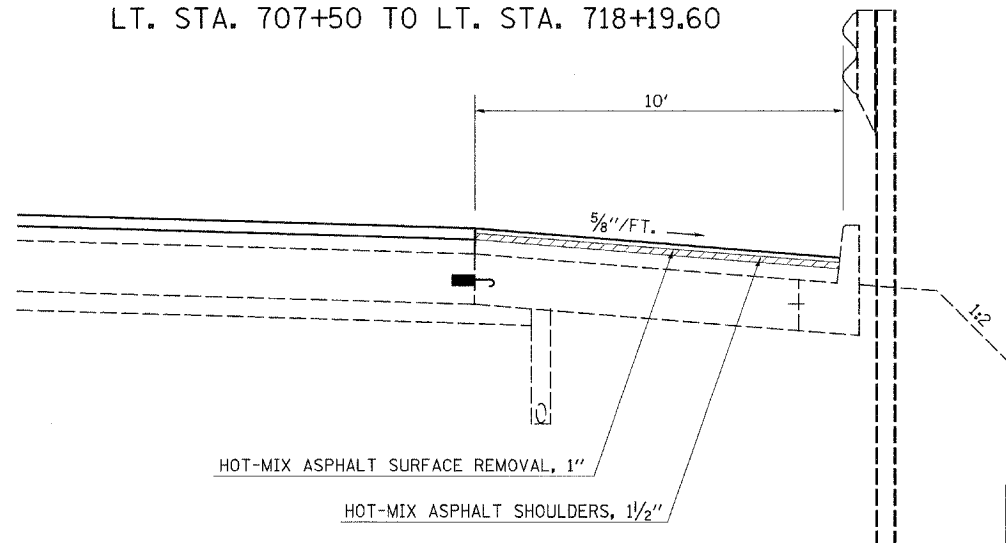

SHOULDER DETAIL

RT. STA. 711+00 TO RT. STA. 715+00

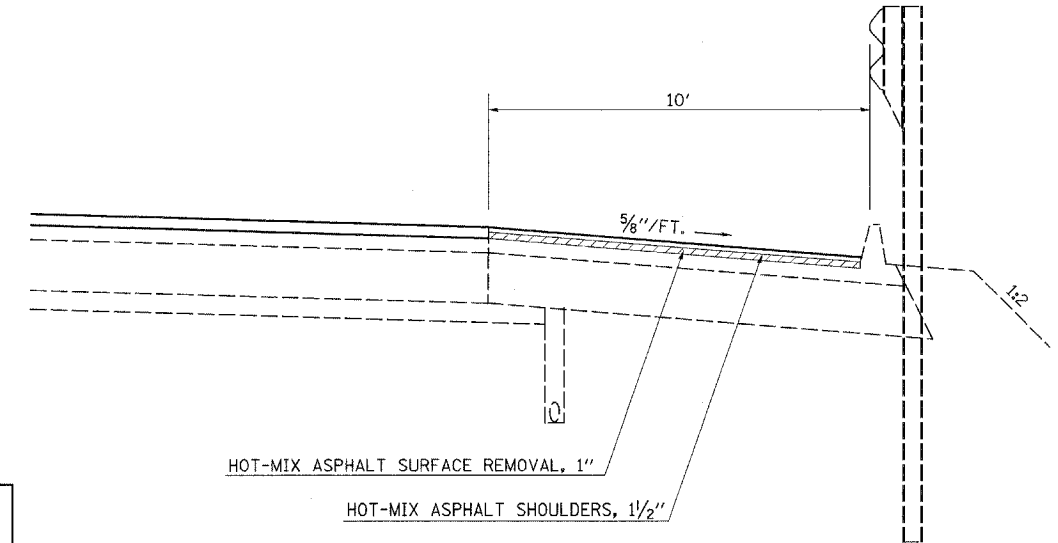

STRUCTURAL DESIGN TRAFFIC:	YEAR 2018		
PV= 9791	SU= 567	MU= 2837	
ROAD/STREET CLASSIFICATION:	CLASS I		
PERCENT OF STRUCTURAL DESIGN TRAFFIC IN DESIGN LANE:			
P= 32	S= 45	M=45	

FILE NAME =	USER NAME = swartzw	DESIGNED -	REVISED -
ca:\projects\74171d\ahhtypicols.74171.dgn		DRAWN -	REVISED -
	PLOT SCALE = 20,0000 1 / IN.	CHECKED -	REVISED -
	PLOT DATE = 3/20/2008	DATE -	REVISED -

STATE OF ILLINOIS
DEPARTMENT OF TRANSPORTATION

TYPICAL CROSS SECTIONS

SCALE: NA SHEET NO. 3 OF 3 SHEETS STA. TO STA.

F.A.I. RTE.	SECTION	COUNTY	TOTAL SHEETS	SH
72	(58,74)(66,67)RS-1	MACON	88	N
CONTRACT NO. 741				
FED. ROAD DIST. NO. ILLINOIS FED. AID PROJECT				

PAVING SCHEDULE
(MAINLINE)

STATION	TO	STATION	LENGTH FEET	PAVEMENT		AREA SQ YD	BITUMINOUS MATERIALS (PRIME COAT) GALLON	AGGREGATE (PRIME COAT) TON	POLYMERIZED HOT MIX ASPHALT SURFACE COURSE, MIX "D", N105 TON	POLYMERIZED HOT MIX ASPHALT BINDER COURSE, IL-19.0, N105 TON	HOT MIX ASPHALT SHOULDERS TON	HOT MIX ASPHALT SHOULDERS, 1 1/2" SQ YD	HOT MIX ASPHALT REMOVAL, 1" SQ YD	HOT MIX ASPHALT REMOVAL, 1 1/2" SQ YD	HOT MIX ASPHALT REMOVAL, 3 1/4" SQ YD	HOT MIX ASPHALT REMOVAL, VARIABLE DEPTH SQ YD	TEMPORARY RAMP SQ YD	AGGREGATE SHOULDERS, TYPE B TON	PAVEMENT REMOVAL SQ YD
				WIDTH FEET	AREA SQ YD														
700+98.00	TO	718+03.15	1,705.1	24.0	9,094.1	1,515.7	30.3	763.9	1,145.9	509.3	71.2	5,749.9			9,094.1	135.8	64.0	91.9	
718+03.15	TO	719+00.65	97.5	24.0	520.0	86.7	1.7	43.7	43.7	29.1	111.9				520.0	595.1	64.0	5.3	
719+00.65	TO	723+18.90	418.3	24.0	2,230.7						31.3				2,230.7	248.6			
723+18.90	TO	724+16.40	97.5	24.0	520.0	86.7	1.7	43.7	43.7	29.1	289.0				520.0	640.9	64.0	5.3	
724+16.40	TO	737+00.00	1,283.6	24.0	6,845.9	1,141.0	22.8	575.1	862.6	383.4	175.0	4,563.9			6,845.9	112.6		69.2	
737+00.00	TO	745+41.90	841.9	24.0	4,490.1	748.4	15.0	377.2	565.8	251.4		2,058.0			4,490.1			45.4	
745+41.90	TO	751+44.00	602.1	24.0	3,211.2	535.2	10.7	269.7	404.6	123.6		2,140.8			3,211.2			32.5	
751+44.00	TO	752+73.44	129.4	24.0	690.3	115.1	2.3	58.0	87.0	38.7		460.2			690.3			7.0	
752+73.44	TO	763+00.00	1,026.6	24.0	5,475.0	912.5	18.2	459.9	689.8	306.6		3,650.0			5,475.0			55.3	
763+00.00	TO	766+22.02	322.0	24.0	1,717.4	286.2	5.7	144.3	216.4	96.2		787.2			1,717.4			17.4	
766+22.02	TO	769+19.96	297.9	24.0	1,589.0	264.8	5.3	133.5	200.2	61.2		1,059.3			1,589.0			16.1	
769+19.96	TO	770+75.06	155.1	24.0	827.2	137.9	2.8	69.5	104.2	46.3		551.5			827.2			8.4	
770+75.06	TO	773+41.84	266.8	24.0	1,422.8	237.1	4.7	119.5	179.3	79.7		948.6			1,422.8			14.4	
773+41.84	TO	777+00.00	358.2	24.0	1,910.2	318.4	6.4	160.5	240.7	107.0		875.5			1,910.2			19.3	
777+00.00	TO	778+31.00	131.0	24.0	698.7	116.4	2.3	58.7	88.0	39.1		465.8			698.7			7.1	
778+31.00	TO	781+71.28	340.3	24.0	1,814.8	302.5	6.0	152.4	228.7	101.6		831.8			1,814.8			18.3	
781+71.28	TO	792+00.00	1,028.7	24.0	5,486.5	914.4	18.3	460.9	691.3	211.2		2,514.6			5,486.5			55.5	
792+00.00	TO	796+30.35	430.4	24.0	2,295.2	382.5	7.7	192.8	289.2	128.5	214.7	1,530.1			2,295.2	296.2		23.2	
796+30.35	TO	797+27.85	97.5	24.0	520.0	86.7	1.7	43.7	43.7	29.1	218.1				520.0	274.2	112.0	5.3	
797+27.85	TO	801+07.85	380.0	24.0	2,026.7						208.9				2,026.7	328.4			
801+07.85	TO	802+05.35	97.5	24.0	520.0	86.7	1.7	43.7	43.7	29.1	206.9				520.0	294.7	112.0	5.3	88.4
802+05.35	TO	841+87.88	3,982.5	24.0	21,240.2	3,540.0	70.8	1,784.2	2,676.3	1,189.4	312.6	14,160.1			21,240.2	286.0		214.7	74.9
841+87.88	TO	844+27.88	240.0	24.0	1,280.0	213.3	4.3	107.5	161.3	71.7					1,280.0	850.3		12.9	
844+27.88	TO	852+80.56	852.7	24.0	4,547.6	757.9	15.2	382.0	573.0	254.7	87.4				4,547.6	2,944.3		46.0	
852+80.56	TO	853+47.99	67.4	24.0	359.6	59.9	1.2	30.2			149.5				359.6	311.0		7.3	
853+47.99	TO	854+00.38	52.4	24.0	279.4	46.6	0.9	23.5			197.1		132.2			22.2		5.6	
854+00.38	TO	855+80.24	179.9	24.0	959.3	159.9	3.2	80.6			692.7		690.8			447.2		19.4	
855+80.24	TO	856+32.74	52.5	24.0	280.0	46.7	0.9	23.5			127.3		137.0			106.5		5.7	
856+32.74	TO	857+00.40	67.7	24.0	360.9	60.1	1.2	30.3			227.4				360.9	348.8		7.3	
857+00.40	TO	881+71.44	2,471.0	24.0	13,178.9	2,196.5	43.9	1,107.0	1,660.5	738.0	90.6				13,178.9	4,661.8		133.2	
881+71.44	TO	884+11.44	240.0	24.0	1,280.0	213.3	4.3	107.5	161.3	71.7					1,280.0	4,886.9		12.9	
884+11.44	TO	910+00.00	2,588.6	24.0	13,805.7	2,300.9	46.0	1,159.7	1,739.5	773.1		8,890.9			13,805.7		64.0	139.5	
SHEET TOTALS			20,902		111,477	17,870	357	9,006	13,140	5,699	3,412	51,238	960	109,959	17,791	480	1,107	163	

PAVING SCHEDULE
(RAMPS)

STATION		TO	STATION	LENGTH FEET	RAMP WIDTH FEET	AREA SQ. YD.	BITUMINOUS MATERIALS (PRIME COAT) GALLON	AGGREGATE (PRIME COAT) TON	POLYMERIZED HOT MIX ASPHALT SURFACE COURSE, MIX "D", N105 TON	POLYMERIZED HOT MIX ASPHALT BINDER COURSE, IL-19.0, N105 TON	HOT MIX ASPHALT SHOULDERS TON	HOT MIX ASPHALT SHOULDERS, 1 1/2" SQ. YD.	HOT MIX ASPHALT REMOVAL, 1" SQ. YD.	HOT MIX ASPHALT REMOVAL, 1 1/2" SQ. YD.	HOT MIX ASPHALT REMOVAL, 3 1/4" SQ. YD.	HOT MIX ASPHALT REMOVAL, VARIABLE DEPTH SQ. YD.	TEMPORARY RAMP SQ. YD.	AGGREGATE SHOULDERS, TYPE B TON	PAVEMENT REMOVAL SQ. YD.	
RAMP D																				
132+08.20	TO	140+38.58	830.4	16.0	3530.7	203.0	4.1	69.8	104.6	46.5	553.6				738.1				7.9	
126+13.69	TO	132+08.20	594.5	16.0	2811.2	158.5	3.2	88.8	133.2	44.4	528.5				1056.9				68.9	
124+93.80	TO	126+13.69	119.9	16.0	5394.7	34.6	0.7	17.9	26.9	11.2	133.2				213.1				11.2	
RAMP A																				
100+00.00	TO	103+22.00	322.0	16.0	1367.7	78.7	1.6	27.0	40.6	18.0	214.7				286.2				3.1	
103+22.00	TO	106+19.79	297.8	16.0	12381.6	79.4	1.6	44.5	66.7	22.2	264.7				529.4				30.3	
106+19.79	TO	107+62.40	142.6	16.0	3707.9	41.2	0.8	21.3	31.9	13.3	158.5				253.5				7.7	
RAMP C																				
106+26.18	TO	107+05.10	78.9	16.0	2231.1	22.8	0.5	11.8	17.7	7.4	87.7				140.3				4.6	
103+59.03	TO	106+26.18	267.2	16.0	12368.1	71.2	1.4	39.9	59.8	19.9	237.5				474.9				30.3	
100+00.00	TO	103+59.03	359.0	16.0	1370.4	87.8	1.8	30.2	45.2	20.1	239.4				319.1				3.1	
RAMP B																				
114+64.50	TO	115+44.60	80.1	16.0	2082.6	23.1	0.5	12.0	17.9	7.5	89.0				142.4				4.3	
115+44.60	TO	118+81.72	337.1	16.0	26054.6	89.9	1.8	50.3	75.5	25.2	299.7				374.6				63.8	
118+81.72	TO	129+10.60	1028.9	16.0	4360.8	251.5	5.0	86.4	129.6	57.6	685.9				914.6				9.8	
Median Cross Over Sta.	704+30				207.7	20.8			17.4		207.7									
Median Cross Over Sta.	708+56				207.7	20.8			17.4		207.7									
SHEET TOTALS				4,458		103,377	1,183	23	535	750	293		3,908		5,443				245	
PROJECT TOTALS				25,360		214,854	19,053	380	9,541	13,890	5,992	3,412	55,146	960	115,402	17,791	480		1,352	163

PAVEMENT MARKING SCHEDULE
(MAINLINE)

STATION		STATION	FEET	FT.	FT.	FT.	FT.	FT.	EACH	EACH
700+98.00	TO	718+03.15	1,705.1	2,455.4	3,250.3	3,410.3		852.6	85.3	0.0
718+03.15	TO	719+00.65	97.5	140.4	195.0	195.0		48.8	4.9	0.0
719+00.65	TO	723+18.90	418.3	0.0	836.5	836.5		209.2		1,882.2
723+18.90	TO	724+16.40	97.5	140.4	195.0	195.0		48.8	4.9	0.0
724+16.40	TO	737+00.00	1,283.6	1,848.4	2,567.2	2,567.2		641.8	64.2	0.0
737+00.00	TO	745+41.90	841.9	1,212.4	1,683.8	841.9		421.0	42.1	0.0
745+41.90	TO	751+44.00	602.1	866.8	1,204.2	712.6		301.0	30.1	0.0
751+44.00	TO	752+73.44	129.4	186.4	258.9	258.9		64.8	6.5	0.0
752+73.44	TO	763+00.00	1,026.6	1,478.0	2,053.1	2,053.1		513.2	51.3	0.0
763+00.00	TO	766+22.02	322.0	463.6	644.0	322.0	100.0	161.0	16.1	0.0
766+22.02	TO	769+19.96	297.9	429.2	595.9	298.0	298.0	149.0	22.9	0.0
769+19.96	TO	770+75.06	155.1	223.2	310.2	210.2	100.0	77.6	10.8	0.0
770+75.06	TO	773+41.84	266.8	384.2	533.6	533.6	266.8	133.4	21.3	0.0
773+41.84	TO	777+00.00	358.2	515.8	716.3	716.3		179.0	17.9	0.0
777+00.00	TO	778+31.00	131.0	188.8	262.0	262.0		65.6	6.6	0.0
778+31.00	TO	781+71.28	340.3	489.8	680.6	389.2		170.2	17.0	0.0
781+71.28	TO	792+00.00	1,028.7	1,481.4	2,057.4	1,028.7		514.4	51.4	0.0
792+00.00	TO	796+30.35	430.4	619.8	860.7	860.7		215.2	21.5	0.0
796+30.35	TO	797+27.85	97.5	140.4	195.0	195.0		48.8	4.9	0.0
797+27.85	TO	801+07.85	380.0	0.0	760.0	760.0		190.0		1,710.0
801+07.85	TO	802+05.35	97.5	140.4	195.0	195.0		48.8	4.9	71.6
802+05.35	TO	841+87.88	3,982.5	5,734.8	7,965.1	7,965.1		1,991.2	199.1	61.0
841+87.88	TO	844+27.88	240.0	345.6	480.0	480.0		120.0	12.0	0.0
844+27.88	TO	852+80.56	852.7	1,227.8	1,705.4	1,705.4		426.4	42.6	0.0
852+80.56	TO	853+47.99	67.4	97.2	134.9	134.9		33.8	3.4	0.0
853+47.99	TO	854+00.38	52.4	75.6	104.8	104.8		26.2	2.6	0.0
854+00.38	TO	855+80.24	179.9	259.0	359.7	359.7		90.0	9.0	0.0
855+80.24	TO	856+32.74	52.5	75.6	105.0	105.0		26.2	2.6	0.0
856+32.74	TO	857+00.40	67.7	97.4	135.3	135.3		33.8	3.4	0.0
857+00.40	TO	881+71.44	2,471.0	3,558.4	4,782.1	4,942.1		1,235.6	123.6	0.0
881+71.44	TO	884+11.44	240.0	345.6	480.0	480.0		120.0	12.0	0.0
884+11.44	TO	910+00.00	2,588.6	3,727.6	5,177.1	5,177.1		1,294.2	129.4	0.0
SHEET TOTALS=			20,902	28,949	41,484	38,431	765	10,452	1,024	3,725

FILE NAME =
c:\projects\74171d\shsch.74171.dgn

USER NAME = swartzw

DESIGNED - JLD

REVISED -

DRAWN - RWS

REVISED -

PLOT SCALE = 20.0000' / IN.

CHECKED - WES

REVISED -

PLOT DATE = 3/20/2008

DATE - 10-07

REVISED -

STATE OF ILLINOIS
DEPARTMENT OF TRANSPORTATION

SCHEDULE OF QUANTITIES (3 OF 8)

SCALE: NA SHEET NO. 3 OF 8 SHEETS STA. TO STA.

F.A.I.
RTE.
72

SECTION
(58,74)(66,67)RS-1

COUNTY
MACON

TOTAL
SHEETS
88

SHE
NO.
11

CONTRACT NO. 741

FED. ROAD DIST. NO. ILLINOIS FED. AID PROJECT

PAVEMENT MARKING SCHEDULE (RAMPS)				SHORT TERM PAVEMENT MARKING	PREFORMED PLASTIC PAVEMENT MARKING, TYPE B-LINE 4" (YELLOW)	PREFORMED PLASTIC PAVEMENT MARKING, TYPE B-LINE 4" (WHITE)	PREFORMED PLASTIC PAVEMENT MARKING, TYPE B-LINE 8"	PREFORMED PLASTIC PAVEMENT MARKING-LINES"	RAISED REFLECTIVE PAVEMENT MARKER	PAVEMENT MARKING GROOVING
STATION		STATION	FEET	FT.	FT.	FT.	FT.	FT.	EACH	EACH
REST AREA RAMPS										
RAMP D										
124+83.80		125+63.50	79.7	3.2	79.7					
125+63.50		127+23.50	160.0	6.4			160.0			
124+83.80		140+38.60	1,554.8	62.2		1,554.8				
127+23.50		132+07.90	484.4	19.4				121.1		
RAMP A										
100+00.00		107+72.40	772.4	30.9		772.4			17.0	17.0
103+21.60		106+69.80	348.2	13.9			348.2		10.0	10.0
106+69.80		107+72.40	102.6	4.1	102.6					
RAMP C										
100+00.00		107+15.10	715.1	28.6	40.0	715.1			18.0	18.0
103+58.00		106+75.10	317.1	12.7			317.1		9.0	9.0
106+75.10		107+15.10	40.0	1.6						
RAMP B										
114+54.50		114+94.60	40.1	1.6	40.1					
114+94.60		115+91.80	97.2	3.9			97.2			
114+54.50		129+10.58	1,456.1	58.2		1,456.1				
115+91.80		118+82.00	290.2	11.6				72.6		
SHEET TOTALS=			6,458	258	262	4,498	922	194	54	54
PROJECT TOTALS=			27,360	29,208	41,747	42,929	1,687	10,645	1,078	3,779

BASE COURSE WIDENING, 10"

LOCATION				LENGTH (FT.)	AREA (SQ. YD)
CH 18					
RT.	46+32.80	TO	48+09.90	177.1	59.0
LT.	47+65.70	TO	48+36.70	71.0	23.7
RT.	51+71.50	TO	52+66.60	95.1	31.7
LT.	51+96.90	TO	53+75.20	178.3	59.4
TOTAL =					174

BRIDGE APPROACH PAVEMENT

LOCATION				LENGTH FEET	WIDTH FEET	AREA SQ YD
RT.	801+72.20	TO	802+02.20	30.0	61.0	203.3
TOTAL =						203.3

BRIDGE APPROACH PAVEMENT CONNECTOR (FLEXIBLE)

LOCATION				LENGTH FEET	WIDTH FEET	AREA SQ YD
RT.	801+81.33	TO	802+27.68			102.2
RT.	802+27.68	TO	802+33.68	6.0	40.0	26.7
TOTAL =						128.9

EARTHWORK SCHEDULE

LOCATION	EARTH EXCAVATION CUBIC YARD	EARTH EXCAVATION ADJ. FOR SHRINKAGE CUBIC YARD	EMBANKMENT CUBIC YARD	EARTHWORK BALANCE WASTE(+) OR SHORTAGE (-) CUBIC YARD
STA. 714+19.26 TO 718+51.77			97	-97
STA. 723+74.74 TO 728+07.25			97	-194
STA. 792+67.62 TO 794+83.87			97	-291
STA. 801+35.49 TO 803+51.74			97	-388
STA. 852+80.56 TO 857+00.40	1,232	924	75	+461

SHRINKAGE FACTOR = 25%

TRAFFIC BARRIER TERMINAL, TYPE 1 SPECIAL (FLARED)

LOCATION				NO. (EACH)
RT. MEDIAN	716+85.27	TO	717+34.78	1.0
LT.	725+37.43	TO	725+88.04	1.0
LT. MEDIAN	724+91.28	TO	725+40.89	1.0
RT. MEDIAN	795+33.84	TO	795+83.09	1.0
RT.	795+16.80	TO	795+66.80	1.0
LT.	802+68.85	TO	803+18.85	1.0
LT. MEDIAN	802+52.32	TO	803+01.56	1.0
TOTAL =				7.0

STEEL PLATE BEAM GUARD RAIL, TYPE A

LOCATION				LENGTH (FEET)
RT. MEDIAN	718+70.98	TO	718+70.98	187.5
LT.	725+37.44	TO	725+37.44	200.0
LT. MEDIAN	725+41.47	TO	725+41.47	187.5
RT.	797+66.80	TO	797+66.80	200.0
RT. MEDIAN	797+20.45	TO	797+20.45	187.5
LT. MEDIAN	803+02.49	TO	803+02.49	187.5
LT.	802+68.85	TO	802+68.85	200.0
TOTAL =				1350.0

TRAFFIC BARRIER TERMINAL, TYPE 6 (SPECIAL)

LOCATION				NO. (EACH)
LT.	718+06.15	TO	718+52.43	1.0
RT.	718+92.83	TO	719+37.86	1.0
LT.	722+88.40	TO	723+34.67	1.0
TOTAL =				3.0

GUARDRAIL MARKER, TYPE A

STATION	TO	STATION	LOCATION	EACH	(COLOR)
706+53.59		725+06.94	LT. SHLD	19.0	CRYSTAL
710+88.00		718+83.09	RT. SHLD	11.0	CRYSTAL
716+45.52		718+75.03	RT. MED	4.0	AMBER
723+42.10		725+82.28	LT. MED	4.0	AMBER
794+93.87		797+33.87	RT. MED	4.0	AMBER
795+26.98		797+66.98	RT. SHLD	4.0	CRYSTAL
800+68.69		803+08.69	LT. SHLD	4.0	CRYSTAL
801+01.74		803+41.74	LT. MED	4.0	AMBER
				TOTAL =	54.0
				TOTAL CRYSTAL	38.0
				TOTAL AMBER	16.0

PAVED SHOULDER REMOVAL

LOCATION				LENGTH FEET	WIDTH FEET	AREA SQ YD
LT. MED	717+39.77	TO	718+66.43	126.7	6.0	84.4
RT. MED	717+59.86		719+07.89	148.0	6.0	98.7
LT. SHLDR	722+97.00		724+68.19	171.2	10.0	190.2
LT. MED	723+15.65		724+68.19	152.5	6.0	101.7
RT. MED	723+49.84		724+75.48	125.6	6.0	83.8
RT. SHLDR	723+67.68		724+75.48	107.8	10.0	119.8
LT. SHLDR	795+21.50		796+24.27	102.8	6.0	68.5
LT. MED	795+21.50		796+70.61	149.1	10.0	165.7
RT. MED	796+16.15		797+57.59	141.4	6.0	94.3
RT. SHLDR	796+16.15		798+03.95	187.8	10.0	208.7
LT. SHLDR	800+31.71		802+19.45	187.7	10.0	208.6
LT. MED	800+78.06		802+19.45	141.4	6.0	94.3
RT. MED	801+54.97		803+70.85	215.9	6.0	143.9
RT. SHLDR	802+11.38		803+70.85	159.5	10.0	177.2
LT. SHLD/MED	852+31.40		856+51.40	420.0	16.0	746.7
RT. SHLD/MED	853+31.30		857+51.30	420.0	16.0	746.7
TOTAL =						3,333.0

DELINEATORS

	STATION	EACH		STATION	EACH		STATION	EACH		STATION	EACH		
RT./LT.	701+00.00	2.0		RT./LT.	839+00.00	2.0	RAMP D RT./LT.	125+00.00	2.0	RT.	120+00.00	1.0	
RT./LT.	705+00.00	2.0		RT./LT.	841+00.00	2.0		RT./LT.	126+00.00	2.0	RT.	121+00.00	1.0
RT./LT.	709+00.00	2.0		RT./LT.	842+75.00	2.0		LT.	127+00.00	1.0	RT.	122+00.00	1.0
RT./LT.	713+00.00	2.0		RT./LT.	844+50.00	2.0		LT.	128+00.00	1.0	RT.	123+00.00	1.0
RT./LT.	717+00.00	2.0		RT./LT.	846+25.00	2.0		LT.	129+00.00	1.0	RT.	124+00.00	1.0
RT./LT.	725+00.00	2.0		RT./LT.	848+00.00	2.0		LT.	130+00.00	1.0	RT.	125+00.00	1.0
RT./LT.	729+00.00	2.0		RT./LT.	849+75.00	2.0		LT.	131+00.00	1.0	RT.	126+00.00	1.0
RT./LT.	733+00.00	2.0		RT./LT.	851+50.00	2.0		LT.	132+00.00	1.0	RT.	127+00.00	1.0
RT./LT.	737+00.00	2.0		RT./LT.	853+25.00	2.0		LT.	133+00.00	1.0	RT.	128+00.00	1.0
RT.	741+00.00	1.0		RT./LT.	855+00.00	2.0		LT.	134+00.00	1.0	RT.	129+00.00	1.0
RT.	745+00.00	1.0		RT./LT.	856+75.00	2.0		LT.	134+00.00	1.0			
RT.	749+00.00	1.0		RT./LT.	858+50.00	2.0		LT.	136+00.00	1.0			
RT./LT.	753+00.00	2.0		RT./LT.	860+25.00	2.0		LT.	137+00.00	1.0			
RT./LT.	757+00.00	2.0		RT./LT.	862+00.00	2.0		LT.	138+00.00	1.0			
RT./LT.	761+00.00	2.0		RT./LT.	863+75.00	2.0		LT.	139+00.00	1.0			
LT.	765+00.00	1.0		RT./LT.	865+50.00	2.0		RAMP A LT.	100+00.00	1.0			
LT.	769+00.00	1.0		RT./LT.	867+25.00	2.0		RT.	102+00.00	1.0			
RT.	773+00.00	1.0		RT./LT.	869+00.00	2.0		RT.	103+00.00	1.0			
RT./LT.	777+00.00	2.0		RT./LT.	870+75.00	2.0		RT.	104+00.00	1.0			
LT.	781+00.00	1.0		RT./LT.	872+50.00	2.0		RT.	105+00.00	1.0			
LT.	785+00.00	1.0		RT./LT.	874+25.00	2.0		RT.	106+00.00	1.0			
LT.	789+00.00	1.0		RT./LT.	876+00.00	2.0		RT./LT.	107+00.00	2.0			
RT./LT.	793+00.00	2.0		RT./LT.	877+75.00	2.0		RT./LT.	108+00.00	2.0			
RT.	797+00.00	1.0		RT./LT.	879+50.00	2.0		RAMP C LT.	102+00.00	1.0			
LT.	801+00.00	1.0		RT./LT.	881+25.00	2.0		LT.	103+00.00	1.0			
RT./LT.	805+00.00	2.0		RT./LT.	883+00.00	2.0		LT.	104+00.00	1.0			
RT./LT.	809+00.00	2.0		RT./LT.	885+00.00	2.0		LT.	105+00.00	1.0			
RT./LT.	813+00.00	2.0		RT./LT.	888+00.00	2.0		LT.	106+00.00	1.0			
RT./LT.	817+00.00	2.0		RT./LT.	891+00.00	2.0		RT./LT.	107+00.00	2.0			
RT./LT.	821+00.00	2.0		RT./LT.	895+00.00	2.0		RAMP B RT./LT.	115+00.00	2.0			
RT./LT.	825+00.00	2.0		RT./LT.	899+00.00	2.0		RT.	116+00.00	1.0			
RT./LT.	829+00.00	2.0		RT./LT.	903+00.00	2.0		RT.	117+00.00	1.0			
RT./LT.	833+00.00	2.0		RT./LT.	907+00.00	2.0		RT.	118+00.00	1.0			
RT./LT.	836+00.00	2.0		RT./LT.	911+00.00	2.0		RT.	119+00.00	1.0			
COLUMN TOTAL		57.0				68.0				40.0		10.0	
PROJECT TOTAL		175.0											



EXISTING STRUCTURE DATA
 CL STATION 721+12.00 (F.A.I. ROUTE 72)
 SKEW 26°-30' RT. FOR.
 APPROX. LENGTH 418'-0"
 (BK.-BK. APPR. BENTS)
 APPROX. HORIZ. CLEARANCE 42'-0"
 CONSTRUCTED AS SECTION 58-66 B
 STRUCTURE No. 058-0093 (E.B.)
 STRUCTURE No. 058-0094 (W.B.)
 DATA OBTAINED FROM OLD PLANS

PAVING OMISSION
 STA. 719+00.65 TO 723+18.90

TRAFFIC BARRIER TERMINAL,
 TYPE 6 (SEE SCHEDULE SHEET 12)

PROPOSED STEEL PLATE BEAM
 GUARDRAIL, TYPE A
 (SEE SCHEDULE SHEET 12)

TRAFFIC BARRIER TERMINAL,
 TYPE 6 (SPECIAL)
 (SEE SCHEDULE SHEET 12)

TEMPORARY RAMP
 (SEE DETAIL SHEET)

PROPOSED STEEL PLATE BEAM
 GUARDRAIL, TYPE A
 (SEE SCHEDULE SHEET 12)

EXISTING PIPE DRAIN
 8"X22", TILE OUTLET HEADWALL

PROJECT BEGINS:
 STA. 700+98.00

EXISTING MEDIAN CROSSOVER
 STA. 704+30

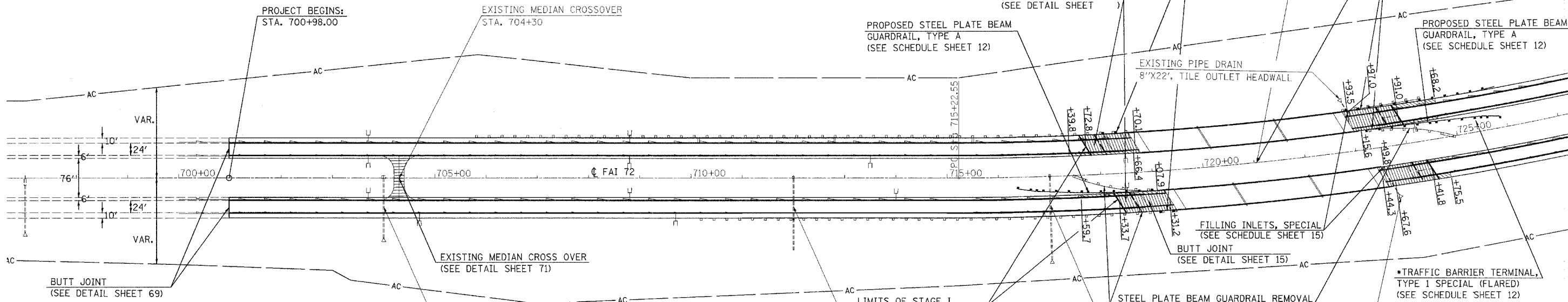

BUTT JOINT
 (SEE DETAIL SHEET 69)

EXISTING MEDIAN CROSS OVER
 (SEE DETAIL SHEET 71)

LIMITS OF STAGE I
 REMOVAL & RESURFACING

FILLING INLETS, SPECIAL
 (SEE SCHEDULE SHEET 15)

BUTT JOINT
 (SEE DETAIL SHEET 15)

STEEL PLATE BEAM GUARDRAIL REMOVAL
 (SEE SCHEDULE SHEET 15)

*TRAFFIC BARRIER TERMINAL,
 TYPE 1 SPECIAL (FLARED)
 (SEE SCHEDULE SHEET 12)

* NOTE: FOR MEDIAN GUARDRAIL LAYOUT
 SEE DETAIL SHEET #72

EXISTING PIPE CULVERT, TYPE 2, RCCP
 24" X 116" WITH 1 END SECTION, 24"
 AND 1 MEDIAN INLET STD. 2250
 RT. STATION 704+00

EXISTING PIPE CULVERT, TYPE 2, RCCP
 24" X 84" WITH 1 END SECTION, 24"
 AND 1 MEDIAN INLET STD. 2240
 RT. STATION 712+00

EXISTING STORM SEWER, TYPE 1
 8"X61", TILE OUTLET HEADWALL

EXISTING PIPE CULVERT, TYPE 2, RCCP
 24" X 86" WITH 1 END SECTION, 24"
 AND 1 MEDIAN INLET STD. 2240
 RT. STATION 717+00

EXISTING PIPE CULVERT, TYPE 1
 BCCSCP 24"X 66', END SECTION
 U.S.F.L. ELEV. 670.00, 81' RT.
 D.S.F.L. ELEV. 645.20 141' RT.
 STA. 712+00

EXISTING PIPE CULVERT, TYPE 1
 BCCSCP 24"X 89', END SECTION
 U.S.F.L. ELEV. 667.00, 86' RT.
 D.S.F.L. ELEV. 633.00 163' RT.
 STA. 717+00

SEC. 31, T18N, R4E, 3rd PM

LEGEND

- HOT MIX ASPHALT SURFACE REMOVAL - VARIABLE DEPTH
- PAVED SHOULDER REMOVAL
- PAVEMENT REMOVAL
- PORTLAND CEMENT CONCRETE SURFACE REMOVAL - BUTT JOINT
- HOT MIX ASPHALT SURFACE REMOVAL - BUTT JOINT

FILE NAME = c:\projects\7417\id\shhtplan.74171.dgn	USER NAME = swartzrw	DESIGNED -	REVISED -
		DRAWN -	REVISED -
	PLOT SCALE = 100,0000' / 1" IN.	CHECKED -	REVISED -
	PLOT DATE = 3/20/2008	DATE -	REVISED -

**STATE OF ILLINOIS
 DEPARTMENT OF TRANSPORTATION**

PLAN SHEET

SCALE: 100 SHEET NO. 1 OF 9 SHEETS STA. 700+98.00 TO STA. 727+00.00

F.A.I. RTE. 72	SECTION (58,74)(66,67)RS-1	COUNTY MACON	TOTAL SHEETS 88	SHE NO. 17
FED. ROAD DIST. NO. ILLINOIS FED. AID PROJECT				CONTRACT NO. 741

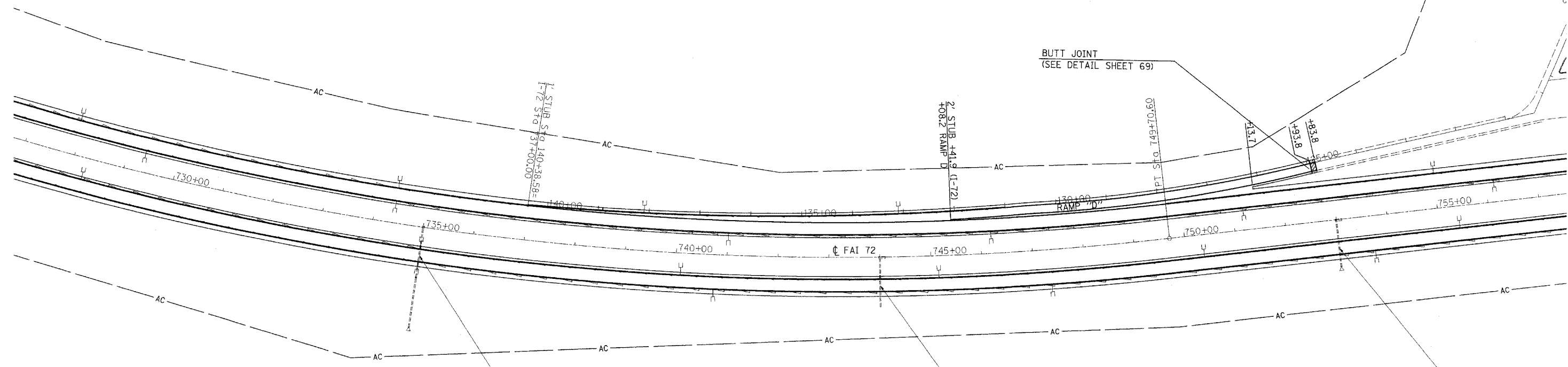
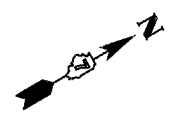

EXISTING PIPE CULVERT, TYPE 2, RCCP
24" X 98' WITH 1 END SECTION, 24"
AND 1 MEDIAN INLET STD. 2240
RT. STATION 735+00

EXISTING PIPE CULVERT, TYPE 2, RCCP
24" X 94' WITH 1 MEDIAN INLET STD. 2243
RT. STATION 744+00

EXISTING PIPE CULVERT, TYPE 2, RCCP
24" X 98' WITH 1 END SECTION, 24"
AND 1 MEDIAN INLET STD. 2243
RT. STATION 753+00

LEGEND

- HOT MIX ASPHALT SURFACE REMOVAL - VARIABLE DEPTH
- PAVED SHOULDER REMOVAL
- PAVEMENT REMOVAL
- PORTLAND CEMENT CONCRETE SURFACE REMOVAL - BUTT JOINT
- HOT MIX ASPHALT SURFACE REMOVAL - BUTT JOINT

FILE NAME = er\projects\74171d\shp\plan.74171.dgn	USER NAME = swartzrw	DESIGNED -	REVISED -
	PLOT SCALE = 100.0000' / IN.	DRAWN -	REVISED -
	PLOT DATE = 3/28/2008	CHECKED -	REVISED -
		DATE -	REVISED -

**STATE OF ILLINOIS
DEPARTMENT OF TRANSPORTATION**

PLAN SHEET

SCALE: 100 SHEET NO. 2 OF 9 SHEETS STA. 727+00.00 TO STA. 757+00.00

F.A.I. RTE.	SECTION	COUNTY	TOTAL SHEETS	SH. N.
72	(58,74)(66,67)RS-1	MACON	88	1
CONTRACT NO. 741				
FED. ROAD DIST. NO.		ILLINOIS FED. AID PROJECT		

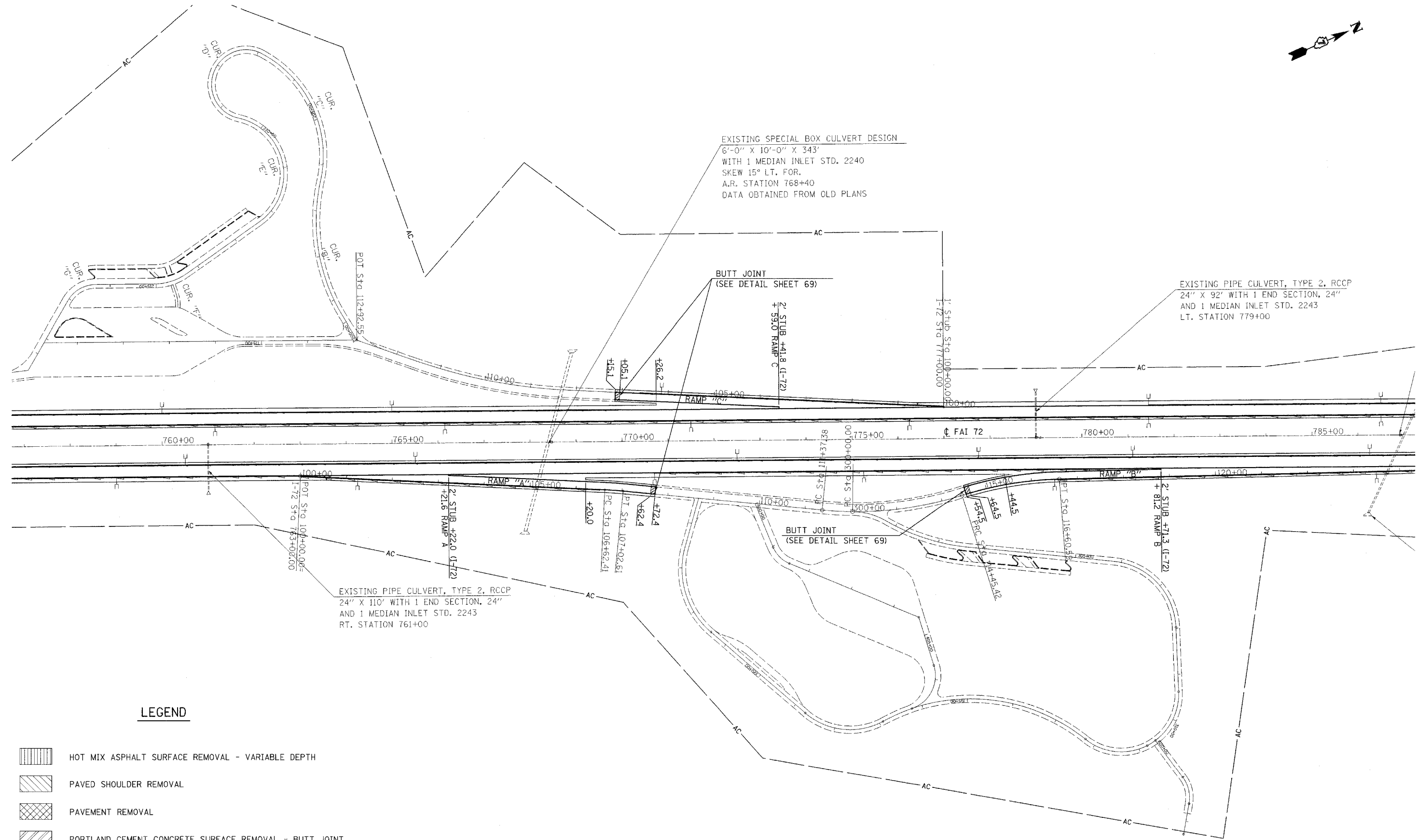
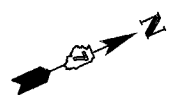

FILE NAME = c:\projects\74171\shplan_74171.dgn	USER NAME = swartzrw	DESIGNED -	REVISED -
		DRAWN -	REVISED -
	PLOT SCALE = 100.0000' / IN.	CHECKED -	REVISED -
	PLOT DATE = 3/20/2008	DATE -	REVISED -

**STATE OF ILLINOIS
 DEPARTMENT OF TRANSPORTATION**

PLAN SHEET	
SCALE: 100	SHEET NO. 3 OF 9 SHEETS
STA. 757+00.00 TO STA. 787+00.00	

F.A.I RTE. 72	SECTION (58,74)(66,67)RS-1	COUNTY MACON	TOTAL SHEETS 88	SH N 1
CONTRACT NO. 741				
FED. ROAD DIST. NO. ILLINOIS FED. AID PROJECT				

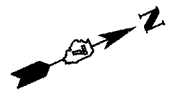

EXISTING STRUCTURE DATA
 ⚬ STATION 799+91.86 (F.A.I. ROUTE 72)
 SKEW 41°-01'.31" RT. FOR.
 APPROX. LENGTH 380'-0 1/2"
 (BK.-BK. APPR. BENTS)
 APPROX. HORIZ. CLEARANCE 42'-0"
 CONSTRUCTED AS SECTION 58-66-HVB
 STRUCTURE No. 058-0095 (E.B.)
 STRUCTURE No. 058-0096 (W.B.)
 DATA OBTAINED FROM OLD PLANS

TRAFFIC BARRIER TERMINAL,
 TYPE 6
 (SEE SCHEDULE SHEET 15)

PROPOSED STEEL PLATE BEAM
 GUARDRAIL, TYPE A
 (SEE SCHEDULE SHEET 12)

STEEL PLATE BEAM
 GUARDRAIL REMOVAL
 (SEE SCHEDULE SHEET 15)

*TRAFFIC BARRIER TERMINAL,
 TYPE 1 SPECIAL (FLARED)
 (SEE SCHEDULE SHEET 12)

PROPOSED STEEL PLATE BEAM
 GUARDRAIL, TYPE A
 (SEE SCHEDULE SHEET 12)

*TRAFFIC BARRIER TERMINAL,
 TYPE 1 SPECIAL (FLARED)
 (SEE SCHEDULE SHEET 12)

LIMITS OF STAGE I
 REMOVAL & RESURFACING

STEEL PLATE BEAM
 GUARDRAIL REMOVAL
 (SEE SCHEDULE SHEET 15)

TEMPORARY RAMP
 (SEE DETAIL SHEET)

PAVING OMISSION
 STA. 797+27.85 TO 801+07.85





TRAFFIC BARRIER TERMINAL,
 TYPE 6
 (SEE SCHEDULE SHEET 15)

BUTT JOINT
 (SEE DETAIL SHEETS 69-70)

EXISTING PIPE CULVERT, TYPE 3, RCCP
 42" X 248' WITH 2 END SECTION, 48"
 AND 1 MEDIAN INLET STD. 2250
 A.R. STATION 813+00

* NOTE: FOR MEDIAN GUARDRAIL LAYOUT
 SEE DETAIL SHEET #72

LEGEND

-  HOT MIX ASPHALT SURFACE REMOVAL - VARIABLE DEPTH
-  PAVED SHOULDER REMOVAL
-  PAVEMENT REMOVAL
-  PORTLAND CEMENT CONCRETE SURFACE REMOVAL - BUTT JOINT
-  HOT MIX ASPHALT SURFACE REMOVAL - BUTT JOINT

FILE NAME = c:\projects\7417\id\shplan.74171.dgn	USER NAME = swartzrw	DESIGNED -	REVISED -
		DRAWN -	REVISED -
	PLOT SCALE = 100.0000' / IN.	CHECKED -	REVISED -
	PLOT DATE = 3/20/2008	DATE -	REVISED -

**STATE OF ILLINOIS
 DEPARTMENT OF TRANSPORTATION**



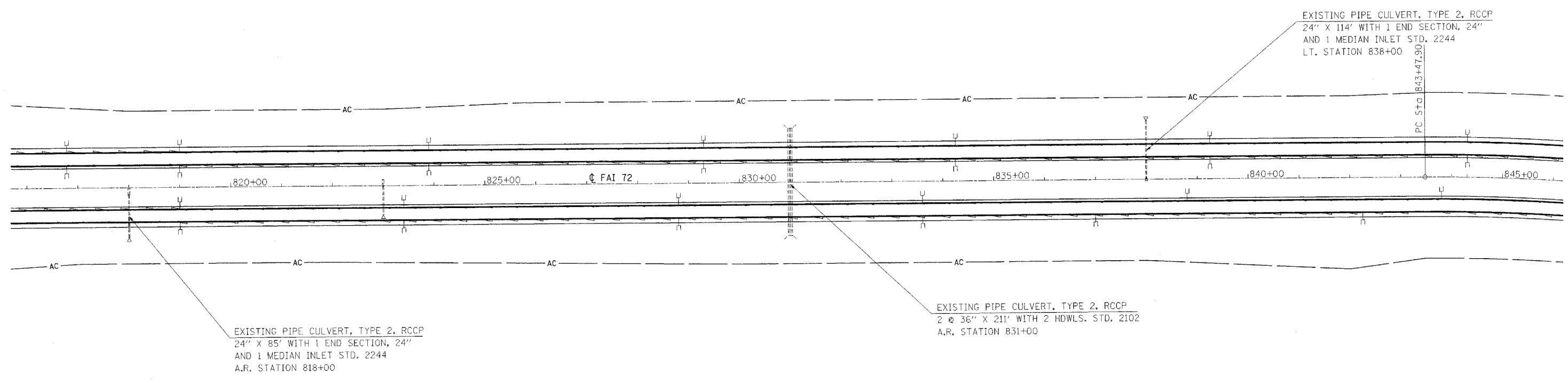
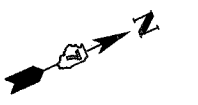

PLAN SHEET

SCALE: 100 SHEET NO. 4 OF 9 SHEETS STA. 786+00.00 TO STA. 816+00.00

F.A.I. RTE. 72	SECTION (58,74)(66,67)RS-1	COUNTY MACON	TOTAL SHEETS 88	SHE NO. 20
FED. ROAD DIST. NO. ILLINOIS FED. AID PROJECT			CONTRACT NO. 741	



LEGEND

-  HOT MIX ASPHALT SURFACE REMOVAL - VARIABLE DEPTH
-  PAVED SHOULDER REMOVAL
-  PAVEMENT REMOVAL
-  PORTLAND CEMENT CONCRETE SURFACE REMOVAL - BUTT JOINT
-  HOT MIX ASPHALT SURFACE REMOVAL - BUTT JOINT

FILE NAME = c:\projects\74171d\shp\plan_74171.dgn	USER NAME = swartzw	DESIGNED -	REVISED -
		DRAWN -	REVISED -
	PLOT SCALE = 100.0000' / IN.	CHECKED -	REVISED -
	PLOT DATE = 3/20/2008	DATE -	REVISED -

**STATE OF ILLINOIS
DEPARTMENT OF TRANSPORTATION**

PLAN SHEET

SCALE: 100 SHEET NO. 5 OF 9 SHEETS STA. 816+00.00 TO STA. 846+00.00

F.A.I. RTE.	SECTION	COUNTY	TOTAL SHEETS	SH. N.
72	(58,74)(66,67)RS-1	MACON	88	2
FED. ROAD DIST. NO.			ILLINOIS FED. AID PROJECT	
CONTRACT NO. 741				

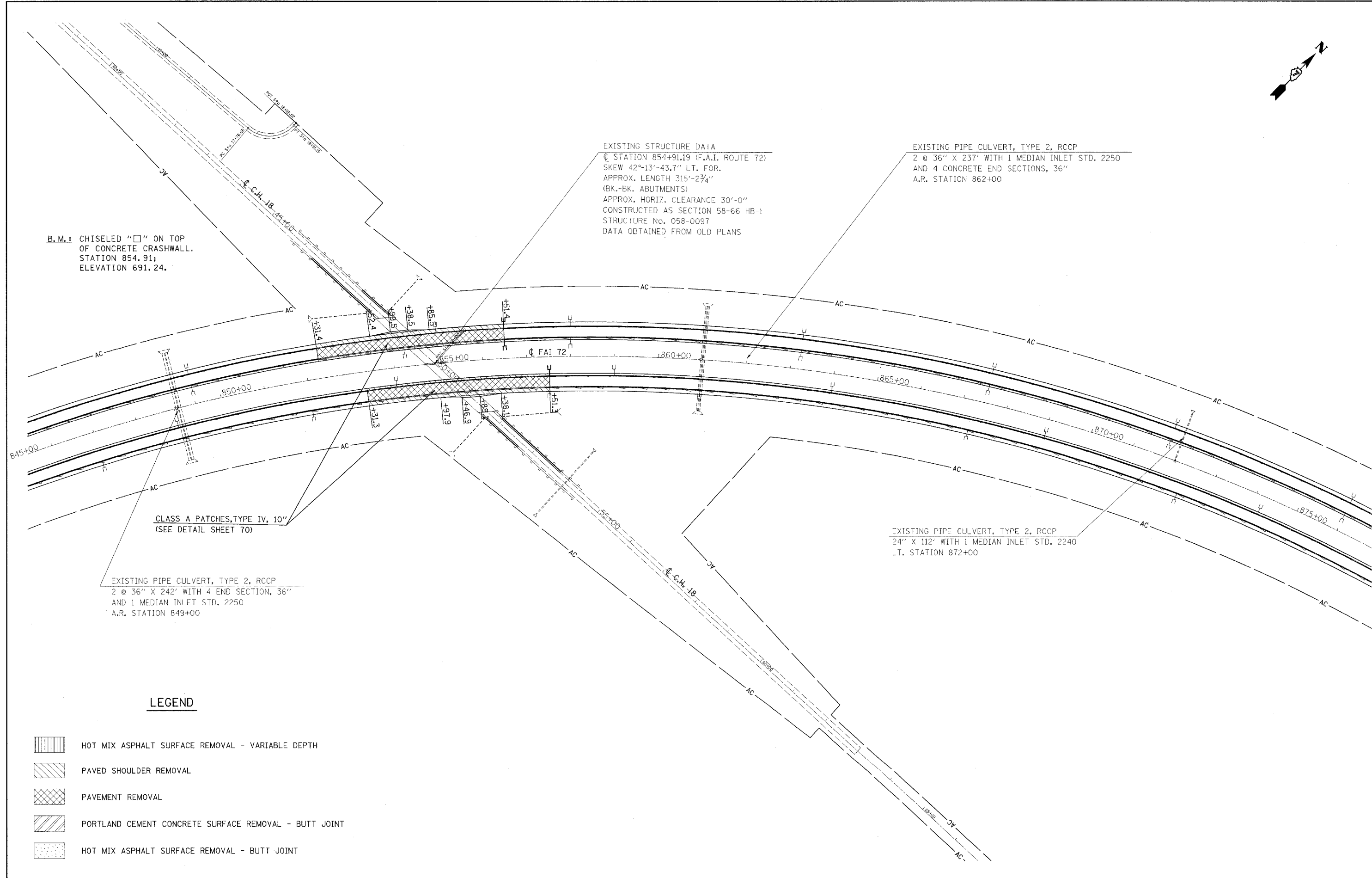
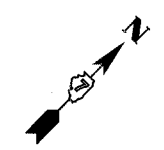

B.M.: CHISELED "□" ON TOP OF CONCRETE CRASHWALL. STATION 854.91; ELEVATION 691.24.

EXISTING STRUCTURE DATA
 STATION 854+91.19 (F.A.I. ROUTE 72)
 SKEW 42°-13'-43.7" LT. FOR.
 APPROX. LENGTH 315'-2 3/4"
 (BK.-BK. ABUTMENTS)
 APPROX. HORIZ. CLEARANCE 30'-0"
 CONSTRUCTED AS SECTION 58-66 HB-1
 STRUCTURE No. 058-0097
 DATA OBTAINED FROM OLD PLANS

EXISTING PIPE CULVERT, TYPE 2, RCCP
 2 @ 36" X 237' WITH 1 MEDIAN INLET STD. 2250
 AND 4 CONCRETE END SECTIONS, 36"
 A.R. STATION 862+00

CLASS A PATCHES, TYPE IV, 10"
 (SEE DETAIL SHEET 70)

EXISTING PIPE CULVERT, TYPE 2, RCCP
 2 @ 36" X 242' WITH 4 END SECTION, 36"
 AND 1 MEDIAN INLET STD. 2250
 A.R. STATION 849+00

EXISTING PIPE CULVERT, TYPE 2, RCCP
 24" X 112' WITH 1 MEDIAN INLET STD. 2240
 LT. STATION 872+00

LEGEND

- HOT MIX ASPHALT SURFACE REMOVAL - VARIABLE DEPTH
- PAVED SHOULDER REMOVAL
- PAVEMENT REMOVAL
- PORTLAND CEMENT CONCRETE SURFACE REMOVAL - BUTT JOINT
- HOT MIX ASPHALT SURFACE REMOVAL - BUTT JOINT

FILE NAME = c:\projects\74171d\shstplan_74171.dgn	USER NAME = swartzrw	DESIGNED -	REVISED -
		DRAWN -	REVISED -
	PLOT SCALE = 100.0000' / IN.	CHECKED -	REVISED -
	PLOT DATE = 3/20/2008	DATE -	REVISED -

**STATE OF ILLINOIS
 DEPARTMENT OF TRANSPORTATION**

PLAN SHEET

SCALE: 100 SHEET NO. 6 OF 9 SHEETS STA. 846+00.00 TO STA. 876+00.00

F.A.I. RTE.	SECTION	COUNTY	TOTAL SHEETS	SH. N.
72	(58,74)(66,67)RS-1	MACON	88	2
CONTRACT NO. 741				
FED. ROAD DIST. NO.		ILLINOIS FED. AID PROJECT		

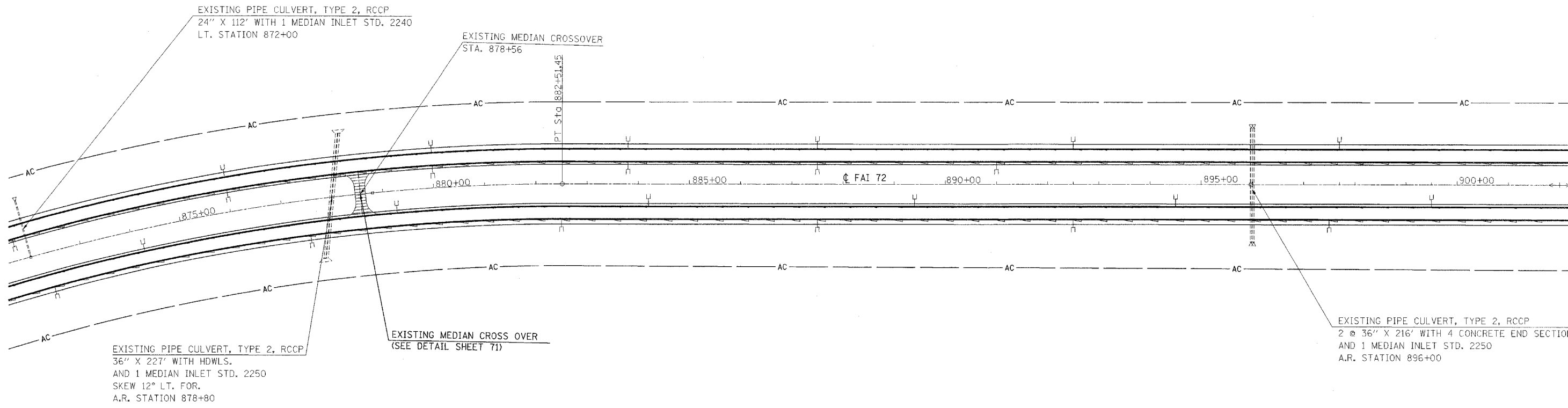

LEGEND

- HOT MIX ASPHALT SURFACE REMOVAL - VARIABLE DEPTH
- PAVED SHOULDER REMOVAL
- PAVEMENT REMOVAL
- PORTLAND CEMENT CONCRETE SURFACE REMOVAL - BUTT JOINT
- HOT MIX ASPHALT SURFACE REMOVAL - BUTT JOINT

FILE NAME = c:\projects\74171d\shp\plan_74171.dgn	USER NAME = swartzw	DESIGNED -	REVISED -
	PLOT SCALE = 100.0000' / IN.	DRAWN -	REVISED -
	PLOT DATE = 3/28/2008	CHECKED -	REVISED -
		DATE -	REVISED -

**STATE OF ILLINOIS
DEPARTMENT OF TRANSPORTATION**

PLAN SHEET

SCALE: 100 SHEET NO. 7 OF 9 SHEETS STA. 872+00.00 TO STA. 902+00.00

F.A.I. RTE.	SECTION	COUNTY	TOTAL SHEETS	SH. N.
72	(58,74)(66,67)RS-1	MACON	88	2
CONTRACT NO. 741				
FED. ROAD DIST. NO.		ILLINOIS FED. AID PROJECT		

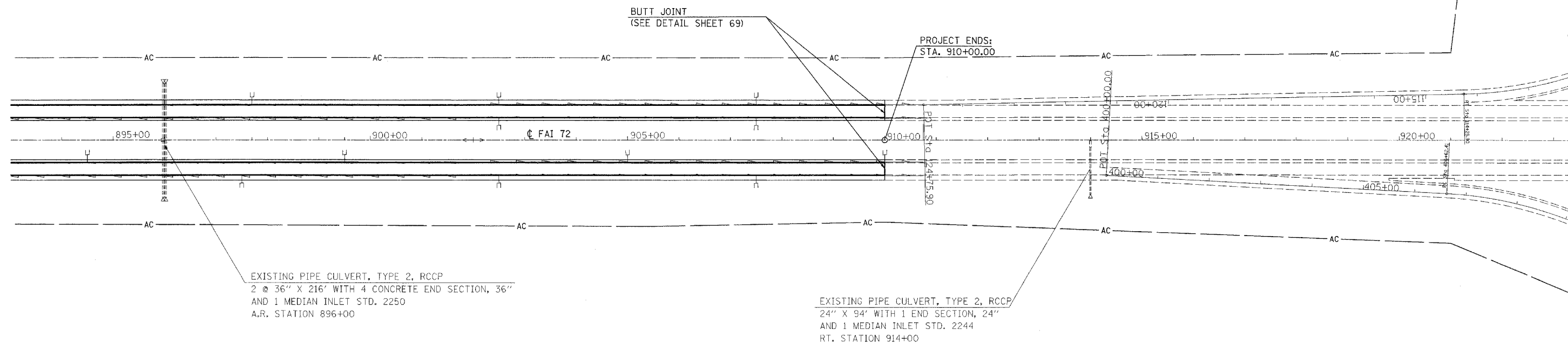

LEGEND

- HOT MIX ASPHALT SURFACE REMOVAL - VARIABLE DEPTH
- PAVED SHOULDER REMOVAL
- PAVEMENT REMOVAL
- PORTLAND CEMENT CONCRETE SURFACE REMOVAL - BUTT JOINT
- HOT MIX ASPHALT SURFACE REMOVAL - BUTT JOINT

FILE NAME = es:\projects\74171d\shp\plan_74171.dgn	USER NAME = swartzrw	DESIGNED -	REVISED -	STATE OF ILLINOIS DEPARTMENT OF TRANSPORTATION	PLAN SHEET	F.A.I RTE. 72	SECTION (58,74)(66,67)RS-1	COUNTY MACON	TOTAL SHEETS 88	SH N 2	
PLOT SCALE = 100.0000' / IN.	CHECKED -	REVISED -	REVISED -			CONTRACT NO. 741					
PLOT DATE = 3/20/2008	DATE -	REVISED -	REVISED -			SCALE: 100 SHEET NO. 8 OF 9 SHEETS STA. 893+00.00 TO STA. 910+00.00					
						FED. ROAD DIST. NO. ILLINOIS FED. AID PROJECT					



EXISTING STRUCTURE DATA
 CL STATION 854+91.19 (F.A.I. ROUTE 72)
 SKEW 42°-13'-43.7" LT. FOR.
 APPROX. LENGTH 315'-2 3/4"
 (BK.-BK. ABUTMENTS)
 APPROX. HORIZ. CLEARANCE 30'-0"
 CONSTRUCTED AS SECTION 58-66 HB-1
 STRUCTURE No. 058-0097
 DATA OBTAINED FROM OLD PLANS

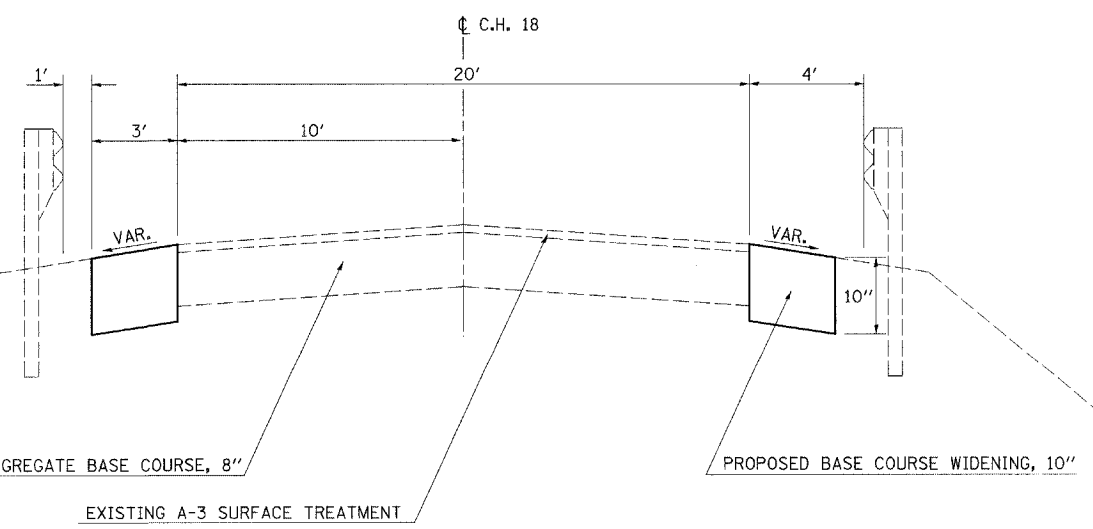
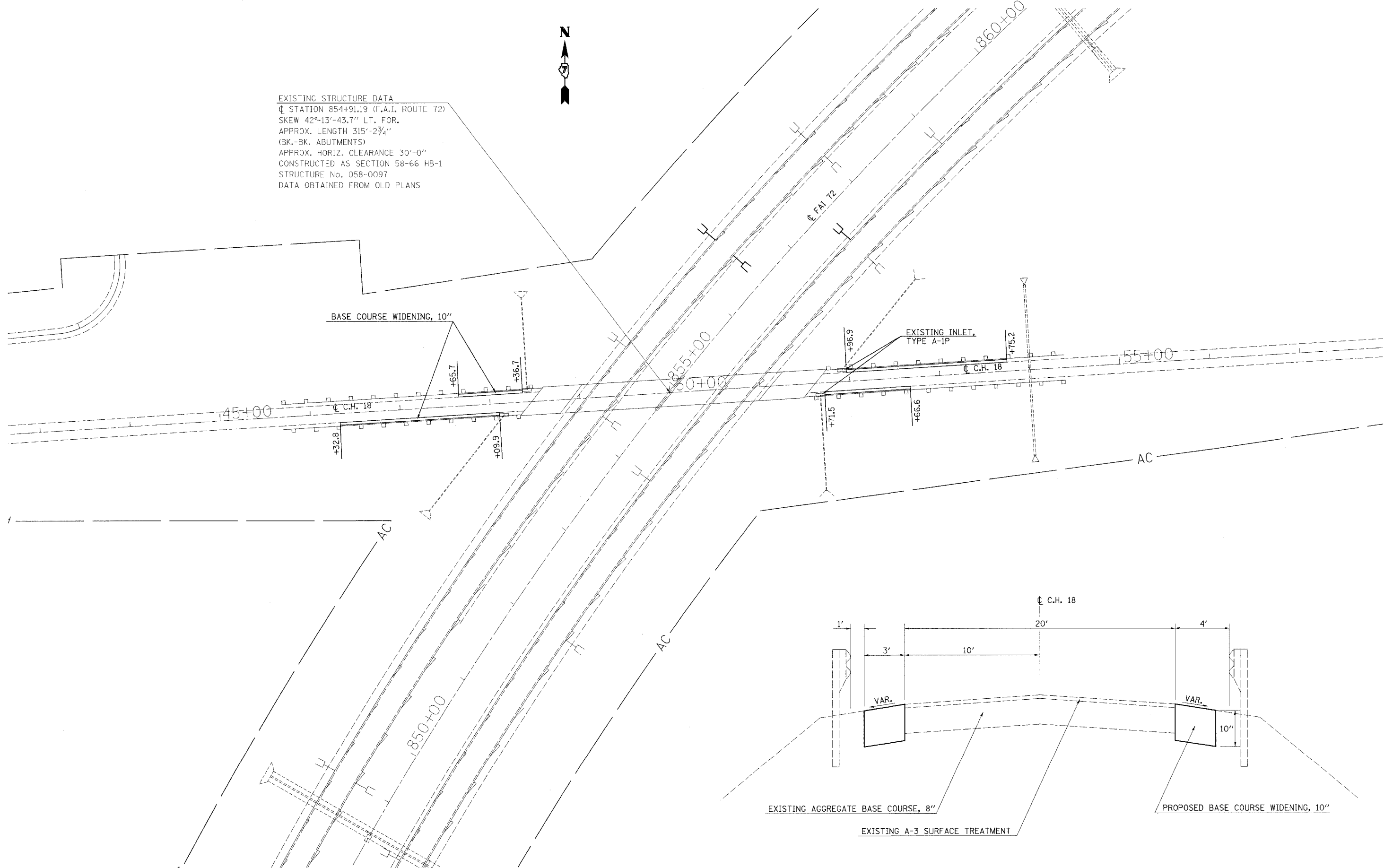

FILE NAME = c:\projects\7417\id\ah\plan.7417\dgn	USER NAME = swartzrw	DESIGNED -	REVISED -
		DRAWN -	REVISED -
	PLOT SCALE = 50.0000' / IN.	CHECKED -	REVISED -
	PLOT DATE = 3/28/2008	DATE -	REVISED -

**STATE OF ILLINOIS
 DEPARTMENT OF TRANSPORTATION**

C.H. 18

SCALE: 50' 1" SHEET NO. 9 OF 9 SHEETS STA. TO STA.

F.A.I. RTE.	SECTION	COUNTY	TOTAL SHEETS	SH. N.
72	(58,74)(66,67)RS-1	MACON	88	2
CONTRACT NO. 7417				
FED. ROAD DIST. NO. ILLINOIS FED. AID PROJECT				

The existing 3 span steel mult-beam structures were constructed in 1975 as section 58-66B at sta. 721+12.00. SN 058-0093 carries FAI-72 eastbound and SN 085-0094 carries FAI-72 westbound. The proposed project consists of new expansion joints, partial and full depth deck patching, replacement of bearings at abutments, new microsilica wearing surface on the deck and approach slabs, new deck drains and structural repair of concrete.

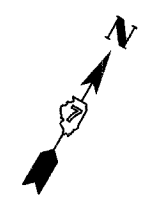
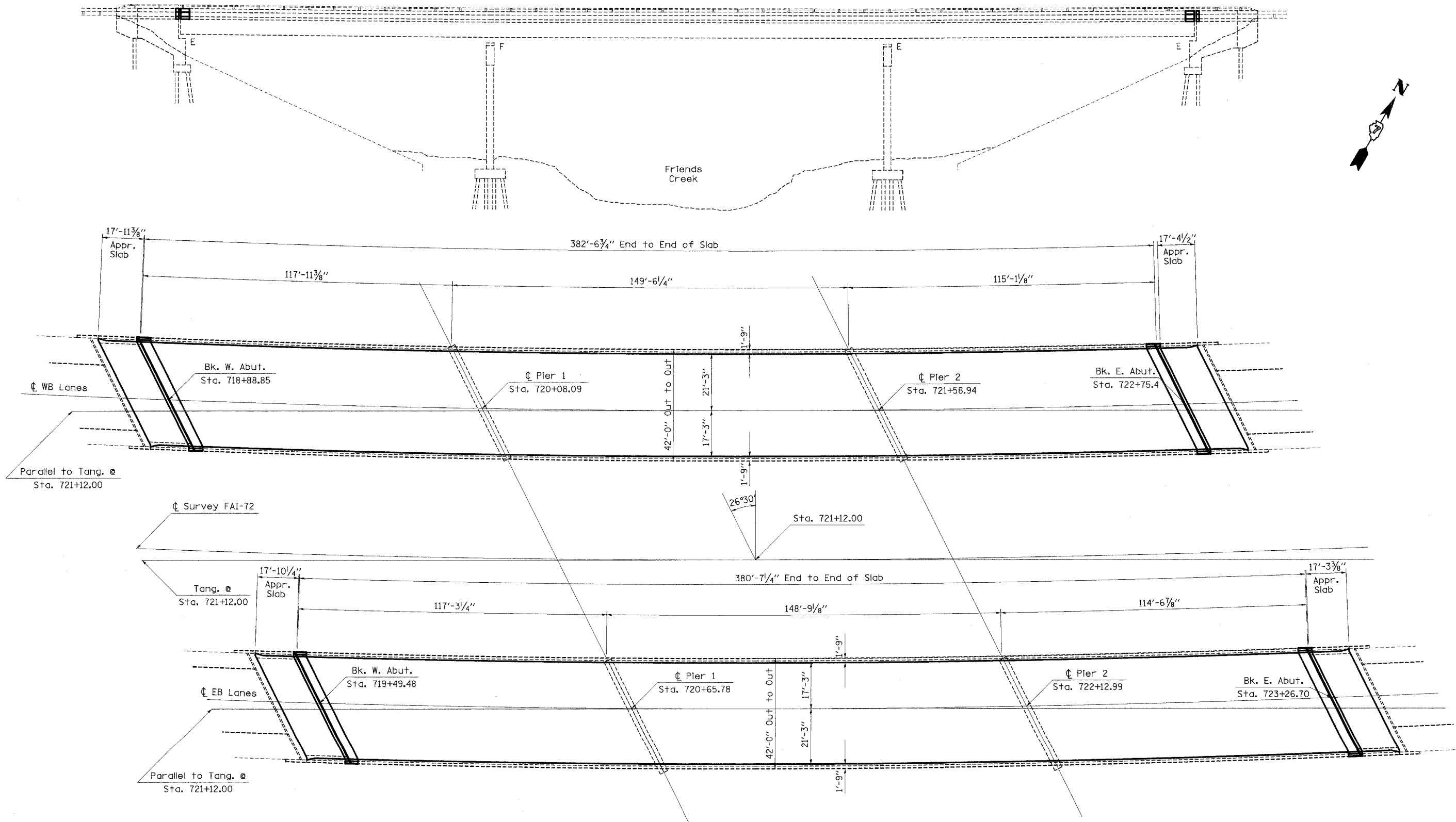

FILE NAME = c:\projects\74171d\karenbridge.dgn
 USER NAME = swartztrw
 PLOT SCALE = 20.00000 ' / IN.
 PLOT DATE = 3/28/2008

DESIGNED -	REVISED -
DRAWN -	REVISED -
CHECKED -	REVISED -
DATE -	REVISED -

**STATE OF ILLINOIS
 DEPARTMENT OF TRANSPORTATION**

**GENERAL PLAN & ELEVATION
 SN. 058-0093 (EB) & 058-0094 (WB)**

SCALE: N/A SHEET NO. 2 OF 52 SHEETS

F.A.I. RTE. 72	SECTION (58,74X66,67)RS-1	COUNTY MACON	TOTAL SHEETS 88
FED. ROAD DIST. NO. ILLINOIS FED. AID PROJECT			CONTRACT NO. 74

Note: Trim existing long. reinf. to accommodate new joint opening (typ.)

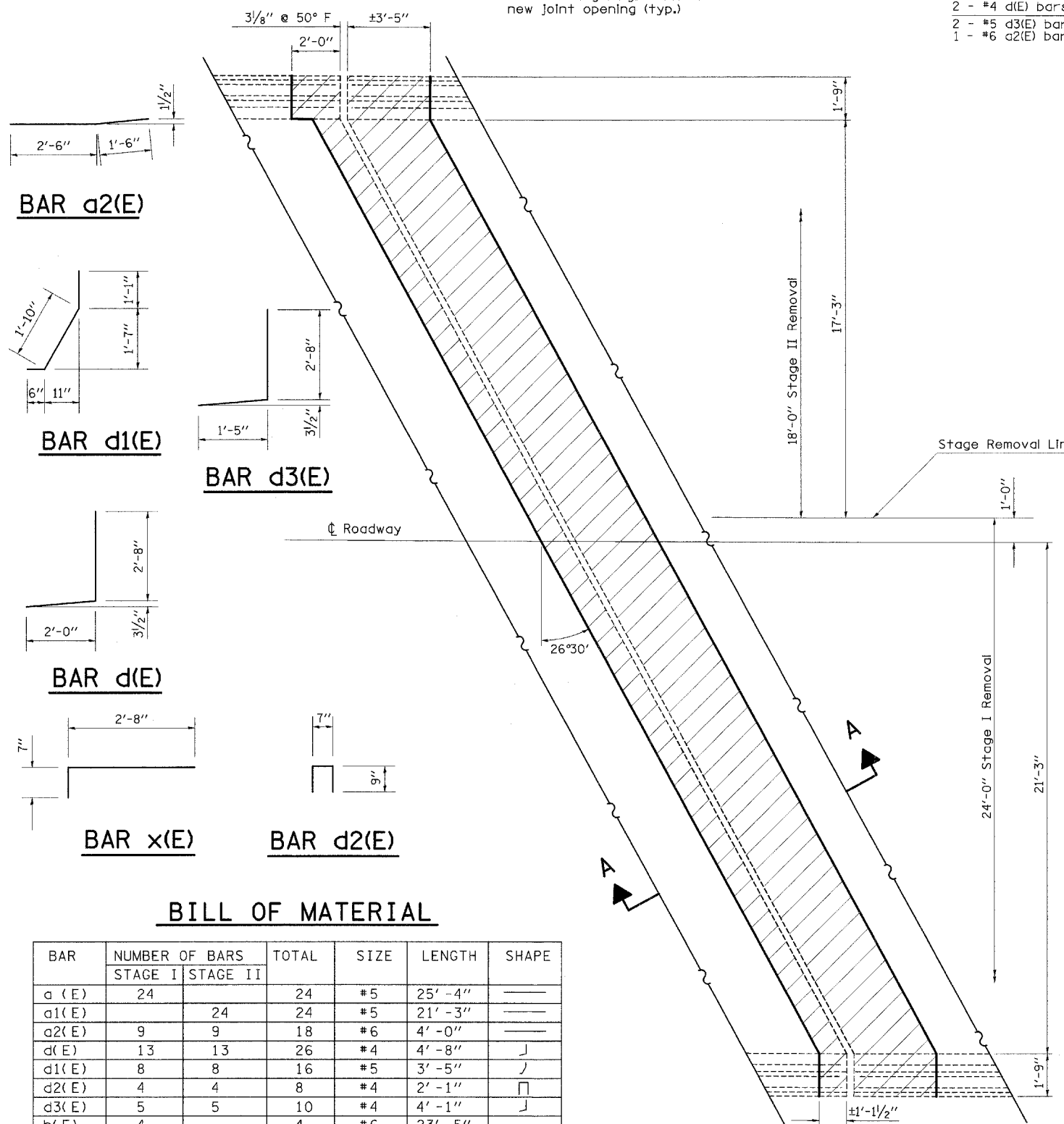

EXISTING PARTIAL PLAN
(West Abutment shown; East Abutment similar)

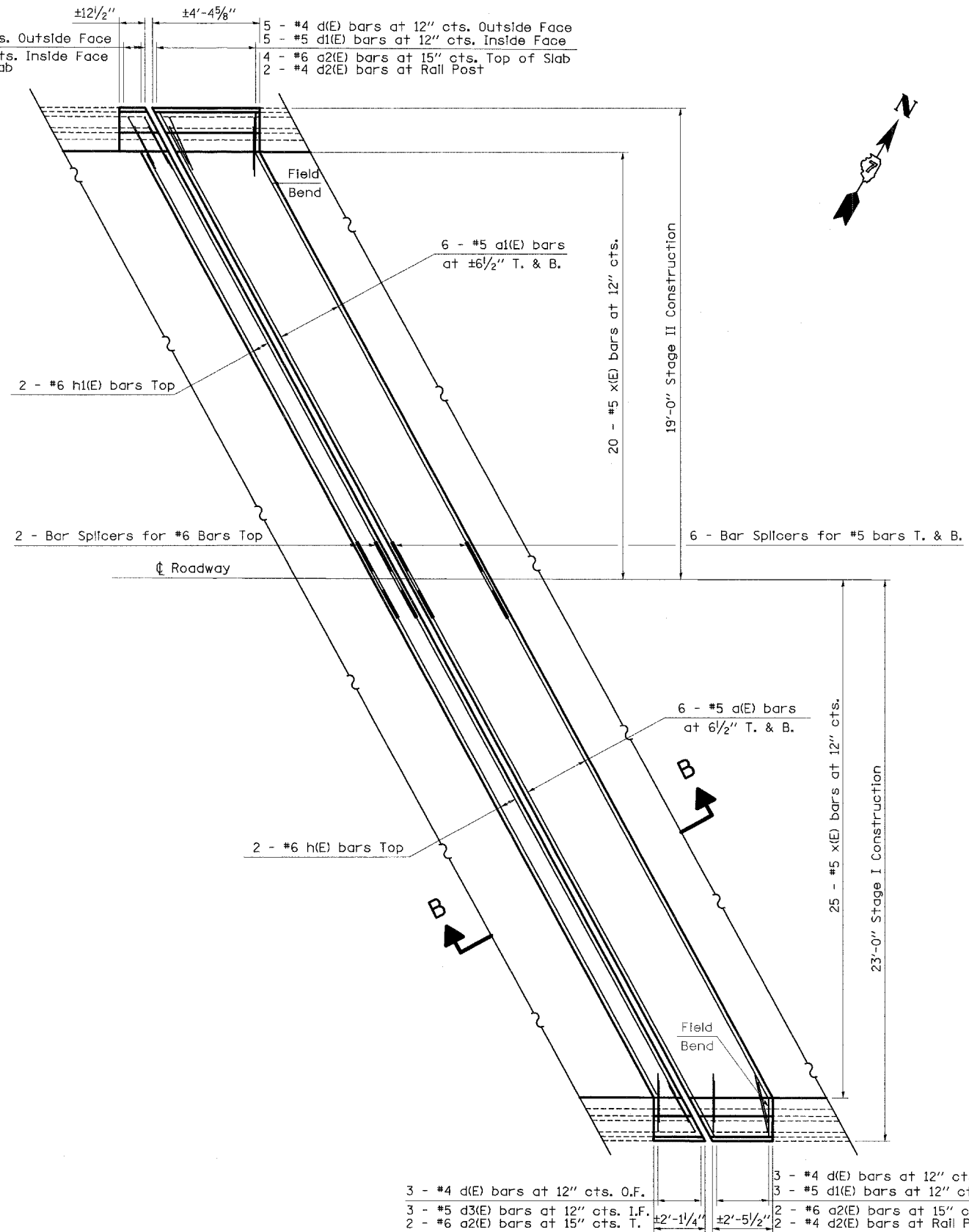

PROPOSED PARTIAL PLAN
(West Abutment shown; East Abutment similar)

BAR a2(E)

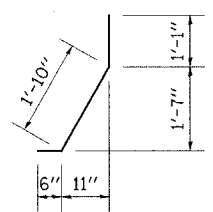

BAR d1(E)

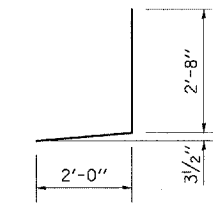

BAR d(E)

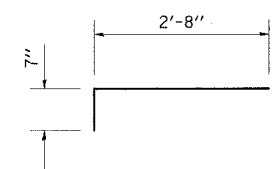

BAR x(E)

BAR d3(E)

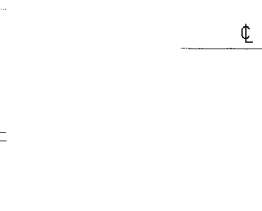

BAR d2(E)

BILL OF MATERIAL

BAR	NUMBER OF BARS		TOTAL	SIZE	LENGTH	SHAPE
	STAGE I	STAGE II				
a (E)	24		24	#5	25' - 4"	—
a1(E)		24	24	#5	21' - 3"	—
a2(E)	9	9	18	#6	4' - 0"	—
d(E)	13	13	26	#4	4' - 8"	J
d1(E)	8	8	16	#5	3' - 5"	J
d2(E)	4	4	8	#4	2' - 1"	□
d3(E)	5	5	10	#4	4' - 1"	J
h(E)	4		4	#6	23' - 5"	—
h1(E)		4	4	#6	19' - 3"	—
x(E)	50	40	90	#5	3' - 3"	—
CONCRETE REMOVAL					CU. YD.	11.6
REINFORCEMENT BARS (EPOXY COATED)					POUND	3410
CONCRETE SUPERSTRUCTURE					CU. YD.	13.5

REINFORCEMENT BARS DESIGNATED (E) SHALL BE EPOXY COATED

Note: Trim existing long. reinf. to accommodate new joint opening (typ.)

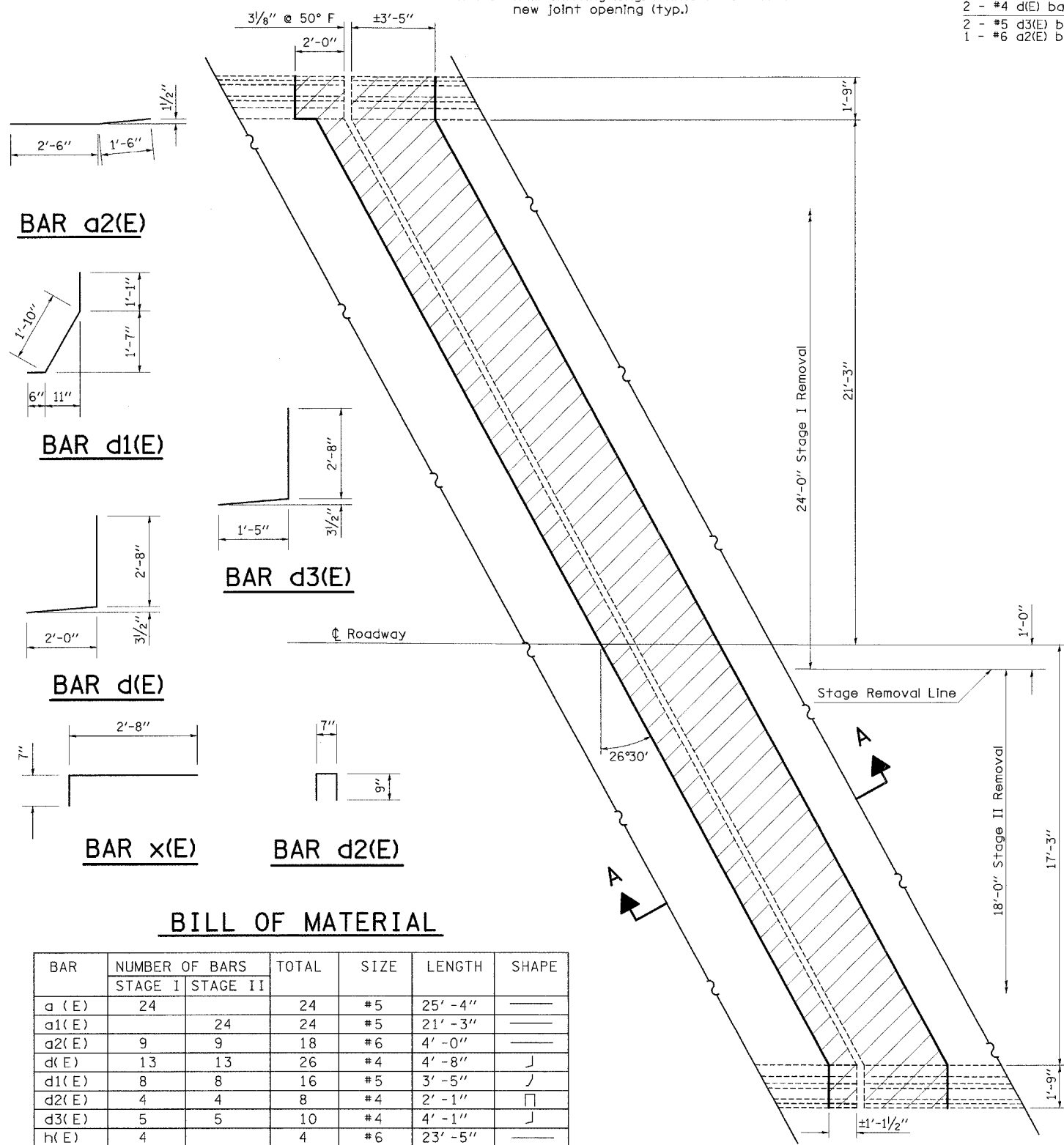

EXISTING PARTIAL PLAN
(West Abutment shown; East Abutment similar)

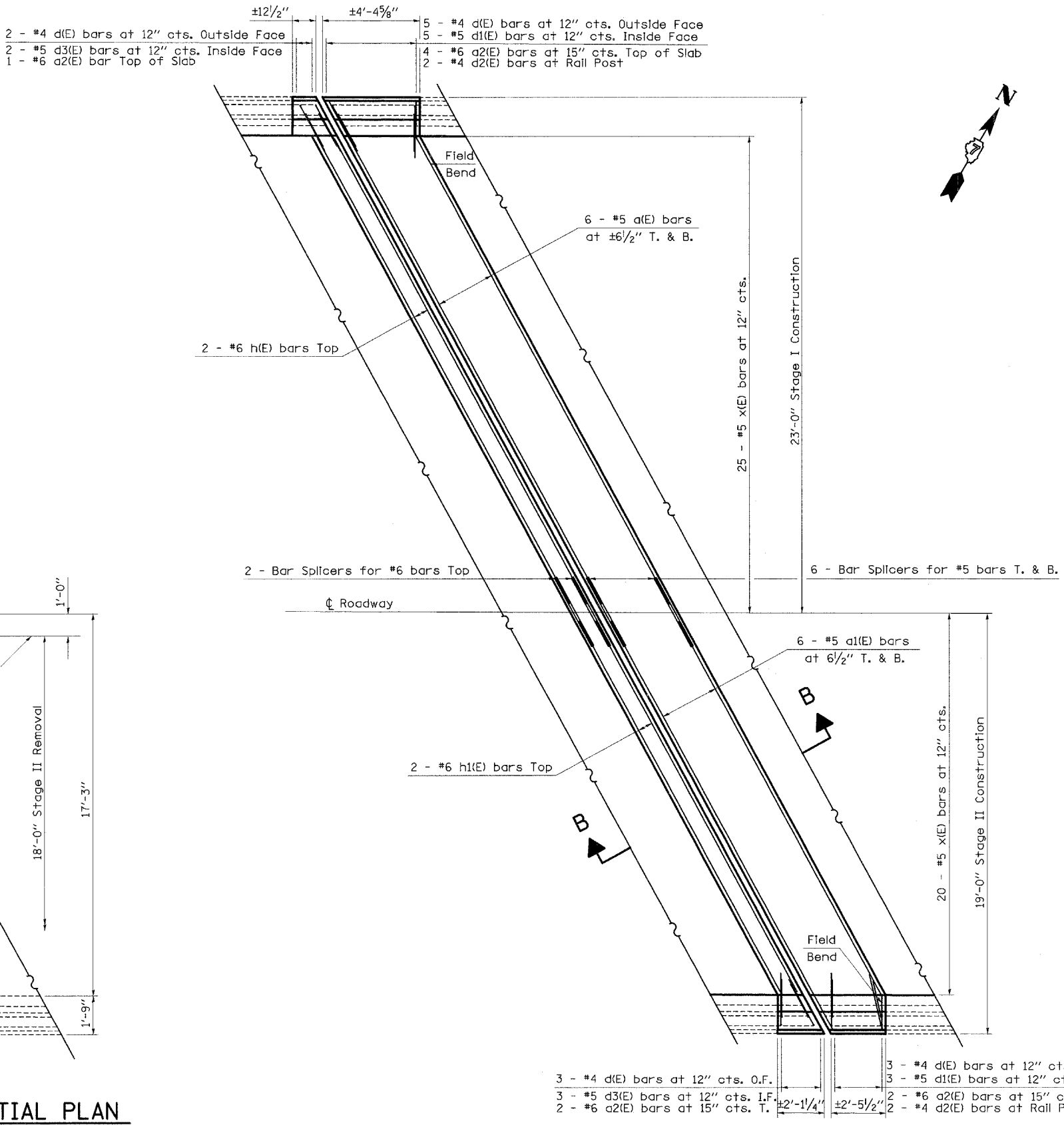

PROPOSED PARTIAL PLAN
(West Abutment shown; East Abutment similar)

BAR a2(E)

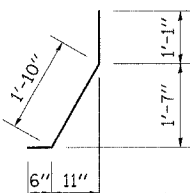

BAR d1(E)

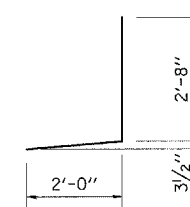

BAR d3(E)

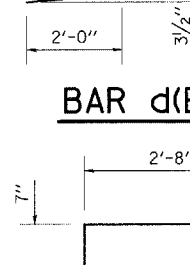

BAR d(E)

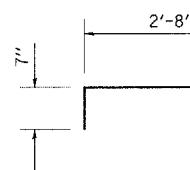

BAR x(E)

BAR d2(E)

BILL OF MATERIAL

BAR	NUMBER OF BARS		TOTAL	SIZE	LENGTH	SHAPE
	STAGE I	STAGE II				
a (E)	24		24	#5	25' - 4"	—
a1(E)		24	24	#5	21' - 3"	—
a2(E)	9	9	18	#6	4' - 0"	—
d(E)	13	13	26	#4	4' - 8"	J
d1(E)	8	8	16	#5	3' - 5"	J
d2(E)	4	4	8	#4	2' - 1"	□
d3(E)	5	5	10	#4	4' - 1"	J
h(E)	4		4	#6	23' - 5"	—
h1(E)		4	4	#6	19' - 3"	—
x(E)	50	40	90	#5	3' - 3"	□
CONCRETE REMOVAL					CU. YD.	11.6
REINFORCEMENT BARS (EPOXY COATED)					POUND	3410
CONCRETE SUPERSTRUCTURE					CU. YD.	13.5

REINFORCEMENT BARS DESIGNATED (E) SHALL BE EPOXY COATED

FILE NAME =	USER NAME = swartzrw	DESIGNED -	REVISED -
ca\projects\74171d\karenbridge.dgn		DRAWN -	REVISED -
	PLOT SCALE = 20,0000 1/4 IN.	CHECKED -	REVISED -
	PLOT DATE = 3/20/2008	DATE -	REVISED -

**STATE OF ILLINOIS
DEPARTMENT OF TRANSPORTATION**

**EXPANSION JOINT REPLACEMENT DETAILS
SN. 058-0094 (WB)**

SCALE: N/A SHEET NO. 4 OF 52 SHEETS STA. TO STA.

F.A.L. RTE.	SECTION	COUNTY	TOTAL SHEETS
72	(58,74X66,67)RS-1	MACON	88
FED. ROAD DIST. NO.			ILLINOIS FED. AID PROJECT

SHEET NO. 52 SHEETS

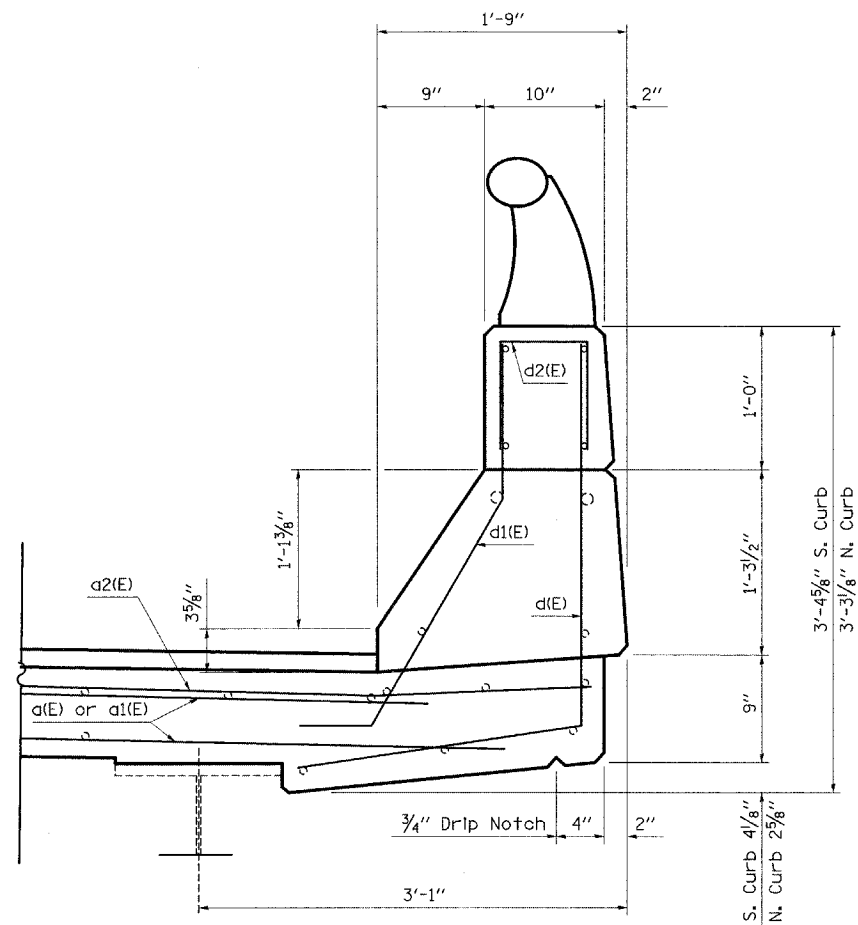

SECTION THRU DECK PARAPET

Note: Rotate d(E), d1(E) and d3(E) bars in parapet to fit horizontal legs in concrete pour.

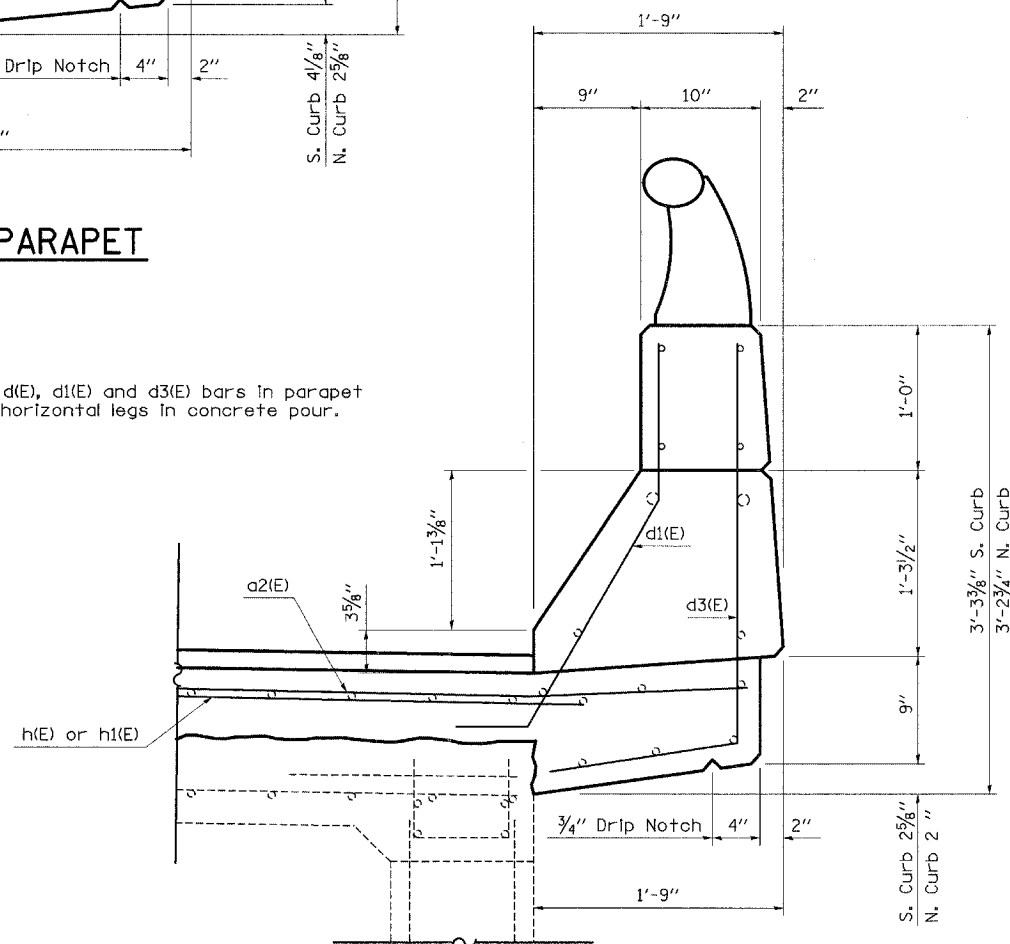

SECTION THRU APPROACH PARAPET

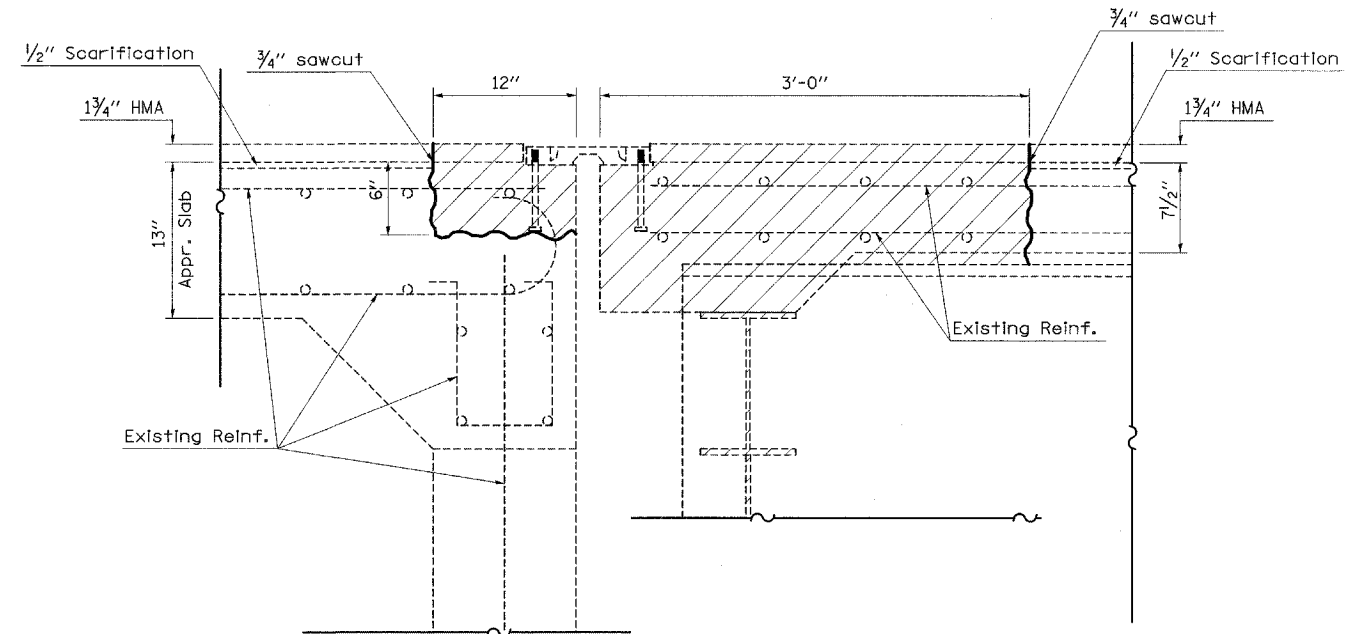

SECTION A-A
(Dimensions at RT L's to end of deck)

- Existing Reinforcement
- Proposed Reinforcement

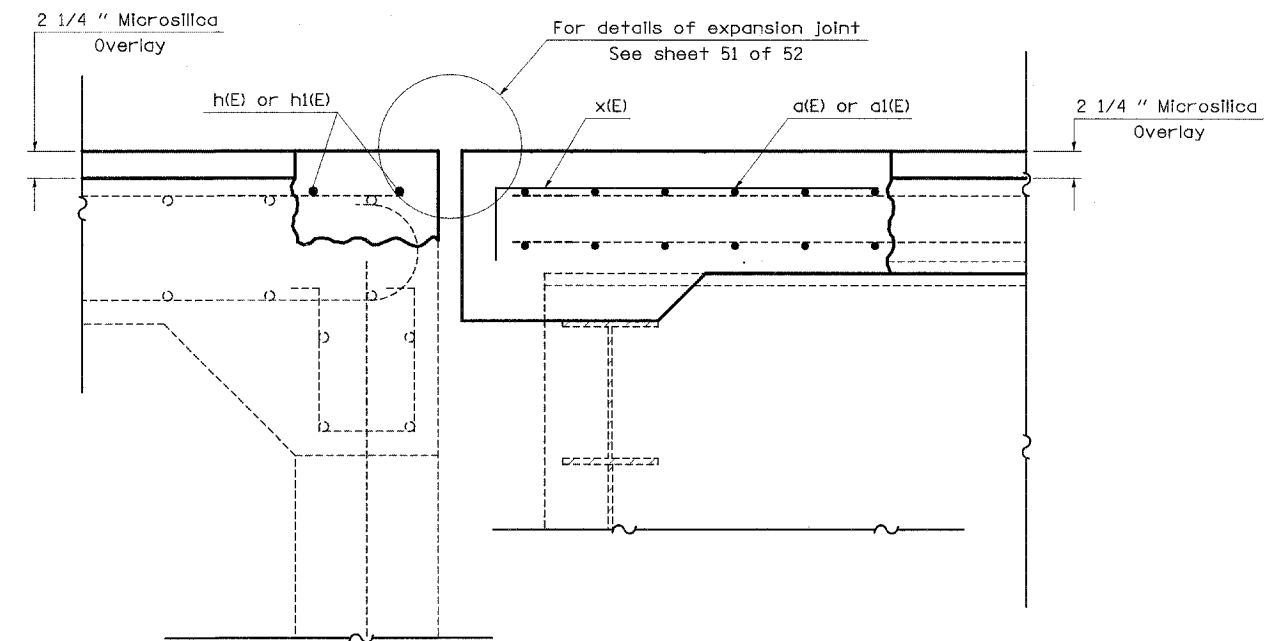

SECTION B-B
(Dimensions at RT L's to end of deck)

FILE NAME = c:\projects\74171d\korenbridge.dgn	USER NAME = swartzw	DESIGNED -	REVISED -
		DRAWN -	REVISED -
	PLOT SCALE = 20,0000 1 / IN.	CHECKED -	REVISED -
	PLOT DATE = 3/20/2008	DATE -	REVISED -

**STATE OF ILLINOIS
DEPARTMENT OF TRANSPORTATION**

**EXPANSION JOINT REPLACEMENT DETAILS
SN. 058-0093 (EB) & SN 058-0094 (WB)**

SCALE: N/A SHEET NO. 5 OF 52 SHEETS STA. TO STA.

F.A.I. RTE. 72	SECTION (58,74X66,67)RS-1	COUNTY MACON	TOTAL SHEETS 88
FED. ROAD DIST. NO. ILLINOIS FED. AID PROJECT			CONTRACT NO. 74

SHEET NO. 52 SHEETS

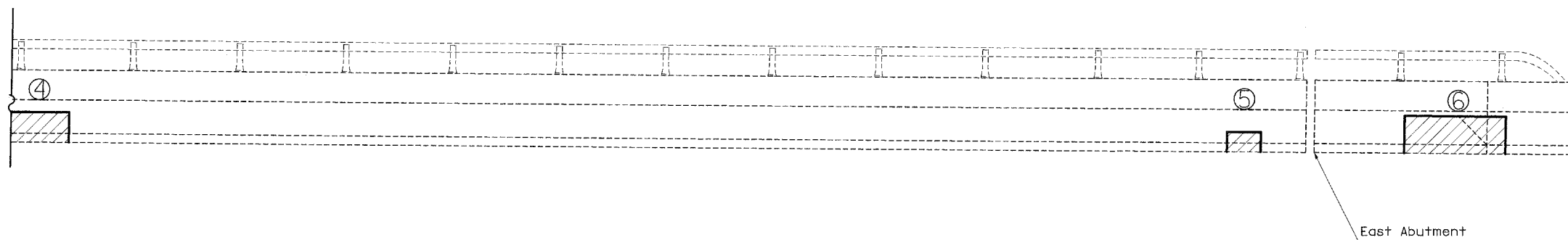
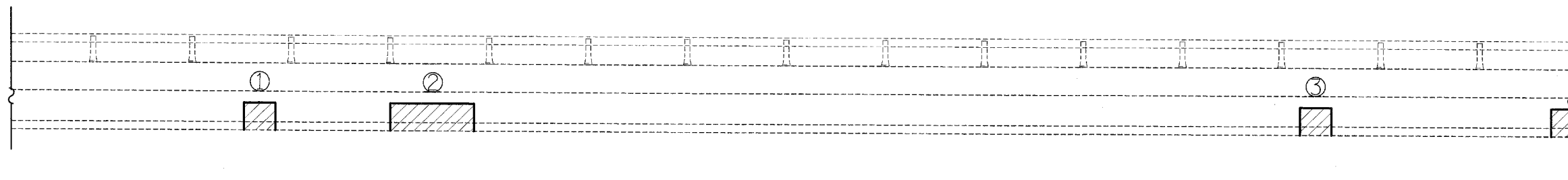
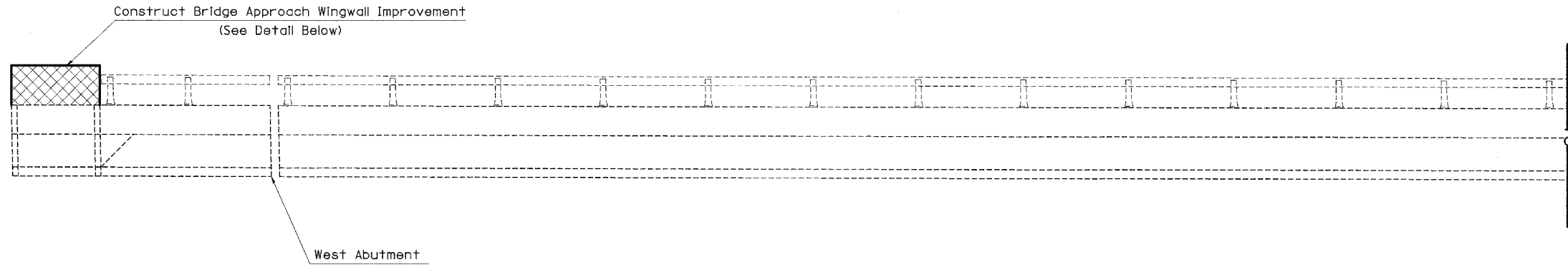

NORTH PARAPET
Looking North

BILL OF MATERIAL

BAR	NUMBER OF BARS	SIZE	LENGTH	SHAPE
				d8(E)
s(E)	9	#5	3' - 11"	
h5(E)	4	#5	7' - 7"	
REINFORCEMENT BARS (EPOXY COATED)			POUND	80
CONCRETE SUPERSTRUCTURE			CU YD	0.3

STRUCTURAL REPAIR

Cost Included In Structural Repair of Concrete (Depth <5'')

PATCH NUMBER	STATION	AREA SQ. FT.
1	720+75	3.0
2	720+92	8.0
3	721+76	3.0
4	722+03	7.0
5	723+10	2.0
6	723+28	11.0
Total		31.0

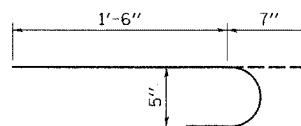

BAR d8(E)

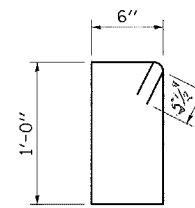

BAR s(E)

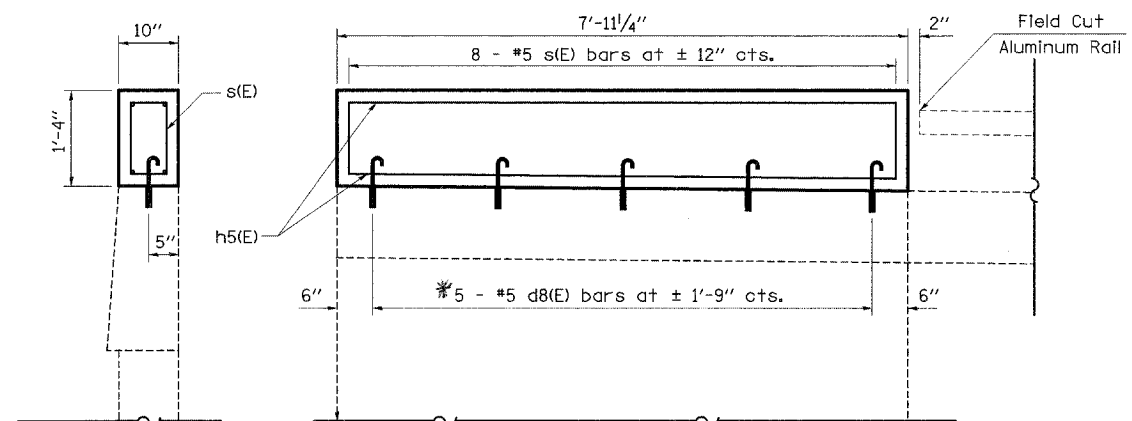

BRIDGE APPROACH WINGWALL IMPROVEMENT DETAIL

Northwest Wingwall Only

FILE NAME = c:\projects\74171d\korenbridge.dgn

USER NAME = swartzrw
PLOT SCALE = 20.0000 1 / IN.
PLOT DATE = 3/28/2008

DESIGNED -
DRAWN -
CHECKED -
DATE -

REVISED -
REVISED -
REVISED -
REVISED -

**STATE OF ILLINOIS
DEPARTMENT OF TRANSPORTATION**

**STRUCTURAL REPAIR - PARAPET
SN. 058-0093 (EB)**

SCALE: N/A SHEET NO. 6 OF 52 SHEETS STA. TO STA.

F.A.I. RTE.	SECTION	COUNTY	TOTAL SHEETS
72	(58,74X66,67)RS-1	MACON	88

CONTRACT NO. 74

SHEET NO. 52 SHEET

TOTAL SHEETS

CONTRACT NO. 74

FED. ROAD DIST. NO. ILLINOIS FED. AID PROJECT

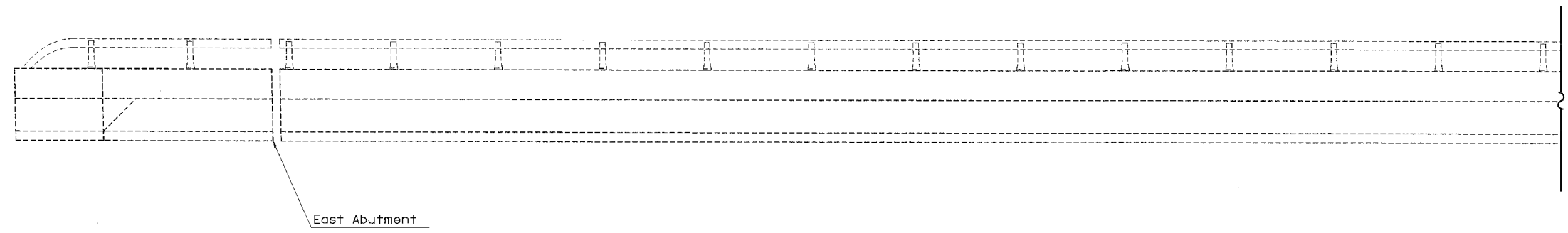

East Abutment

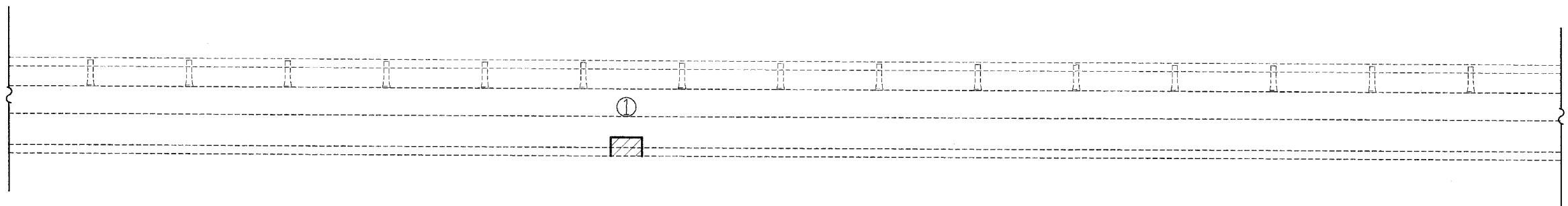

①

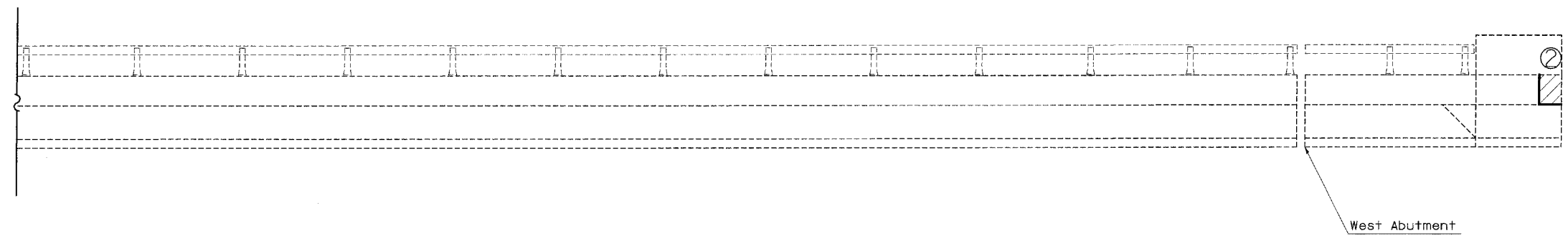

West Abutment

STRUCTURAL REPAIR

Cost Included In Structural Repair
of Concrete (Depth <5")

PATCH NUMBER	STATION	AREA SQ FT
1	721+62	2.0
2	719+65	2.0
Total		4.0

SOUTH PARAPET

Looking South

FILE NAME =
c:\projects\74171d\karanbridge.dgn

USER NAME = swartzrw
PLOT SCALE = 20.0000' / IN.
PLOT DATE = 3/20/2008

DESIGNED -
DRAWN -
CHECKED -
DATE -

REVISED -
REVISED -
REVISED -
REVISED -

**STATE OF ILLINOIS
DEPARTMENT OF TRANSPORTATION**

**STRUCTURAL REPAIR - PARAPET
SN. 058-0093 (EB)**
SCALE: N/A SHEET NO. 7 OF 52 SHEETS STA. TO STA.

F.A.I. RTE. 72	SECTION (58,74X66,67)RS-1	COUNTY MACON	TOTAL SHEETS 88
FED. ROAD DIST. NO.			ILLINOIS FED. AID PROJECT

SHEET NO. 52 SHEETS

CONTRACT NO. 74

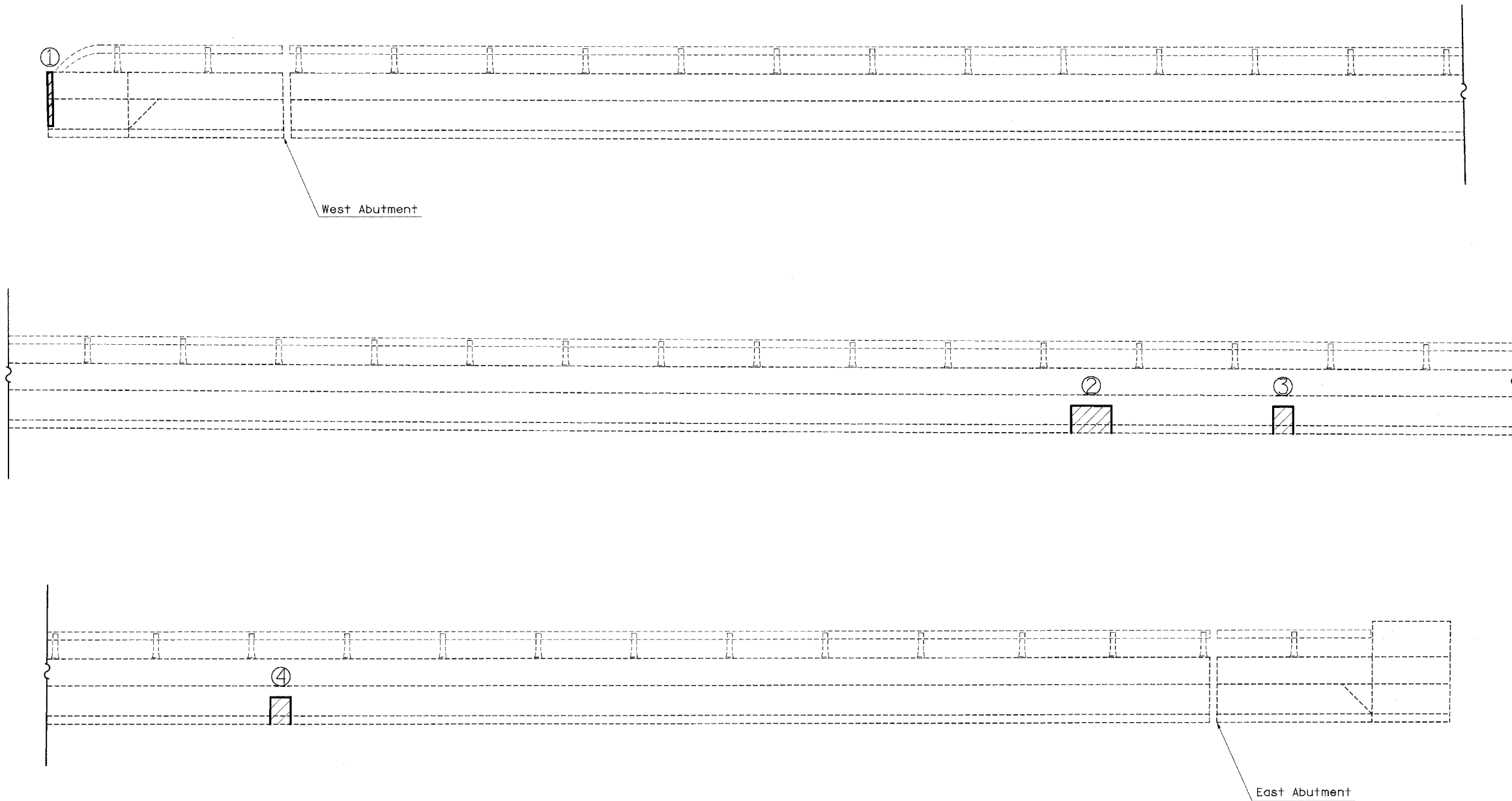

NORTH PARAPET
Looking North

STRUCTURAL REPAIR

Cost Included in Structural Repair
of Concrete (Depth <5')

PATCH NUMBER	STATION	AREA SQ FT
1	718+55	1.0
2	721+07	4.0
3	721+26	2.0
4	721+72	2.0
	Total	9.0

FILE NAME =
c:\projects\74171d\karenbridge.dgn

USER NAME = swartzrw
PLOT SCALE = 20.0000' / IN.
PLOT DATE = 3/20/2008

DESIGNED -
DRAWN -
CHECKED -
DATE -

REVISED -
REVISED -
REVISED -
REVISED -

**STATE OF ILLINOIS
DEPARTMENT OF TRANSPORTATION**

**STRUCTURE REPAIR - PARAPET
SN. 058-0094 (WB)**

SCALE: N/A SHEET NO. 8 OF 52 SHEETS STA. TO STA.

F.A.I. RTE.	SECTION	COUNTY	TOTAL SHEETS
72	(58,74X66,67)RS-1	MACON	88
FED. ROAD DIST. NO.			ILLINOIS FED. AID PROJECT

SHEET NO. 8 OF 52 SHEETS

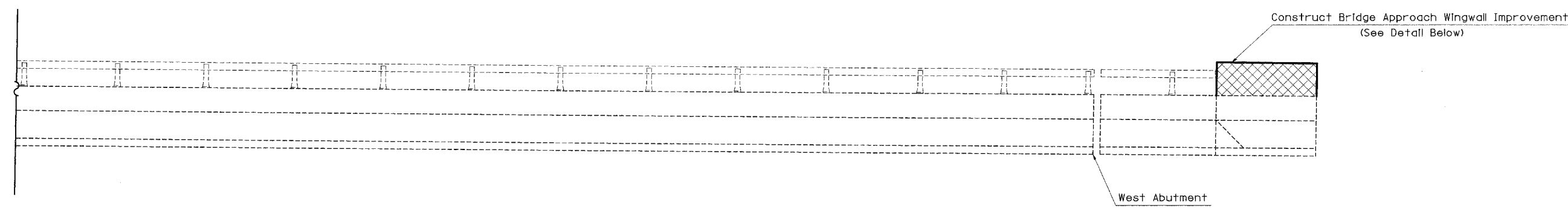
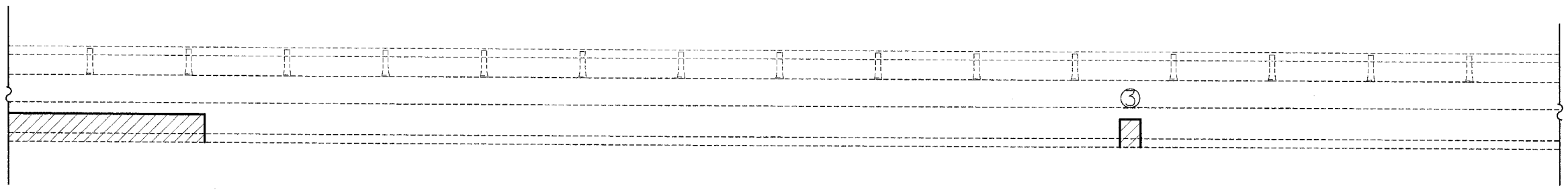
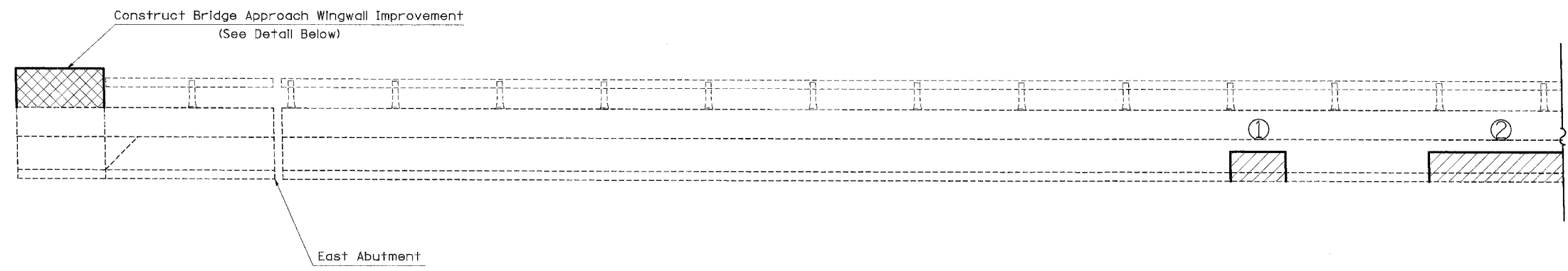

STRUCTURAL REPAIR

Cost Included in Structural Repair of Concrete (Depth <5')

PATCH NUMBER	STATION	AREA SQ FT
1	718+55	1.0
2	721+07	4.0
3	721+26	2.0
4	721+72	2.0
Total		9.0

SOUTH PARAPET
Looking South
BILL OF MATERIAL

BAR	NUMBER OF BARS	SIZE	LENGTH	SHAPE
d8(E)	10	#5	2'-1"	—
s(E)	18	#5	3'-11"	□
h5(E)	4	#5	7'-7"	—
h6(E)	4	#5	7'-4"	—
REINFORCEMENT BARS (EPOXY COATED)			POUND	120
CONCRETE SUPERSTRUCTURE			CU YD	0.7

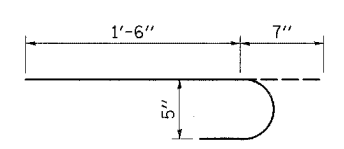

BAR d8(E)

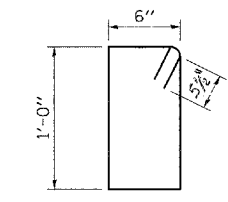

BAR s(E)

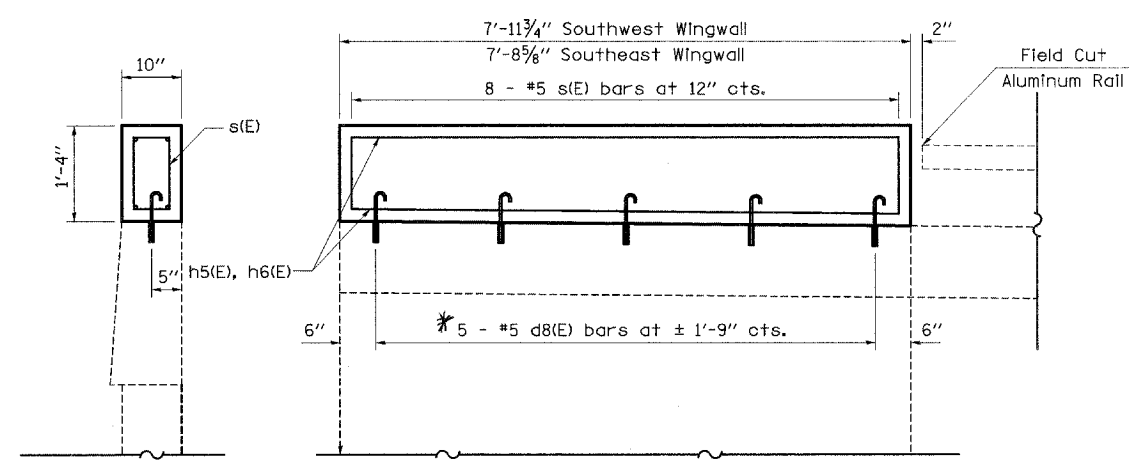

BRIDGE APPROACH WINGWALL IMPROVEMENT DETAIL
Southeast & Southwest Wingwalls

* Epoxy Grouted Bars In accordance with Art. 584 of the Standard Specs.

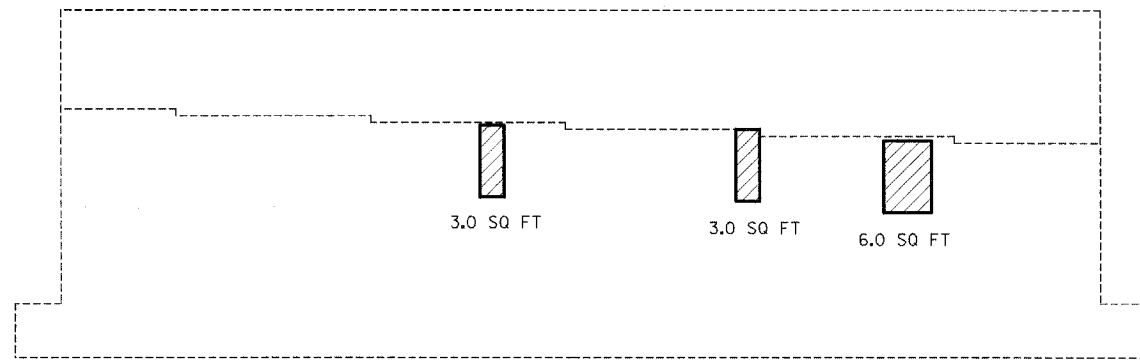

WEST ABUTMENT

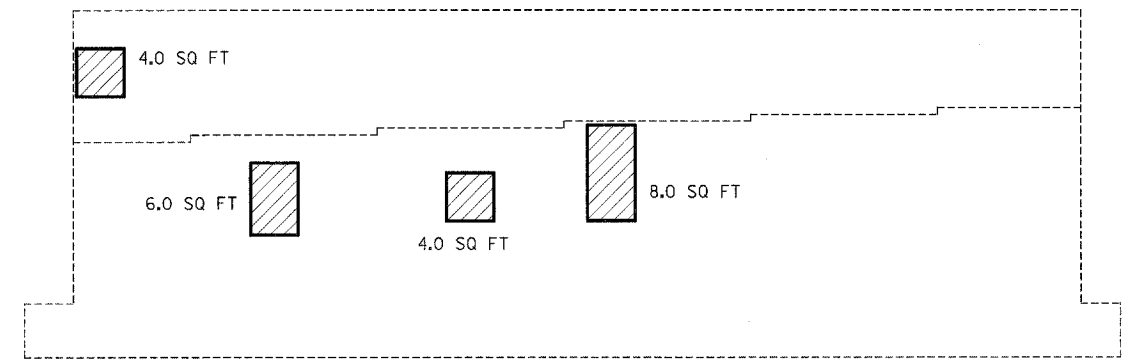

EAST ABUTMENT

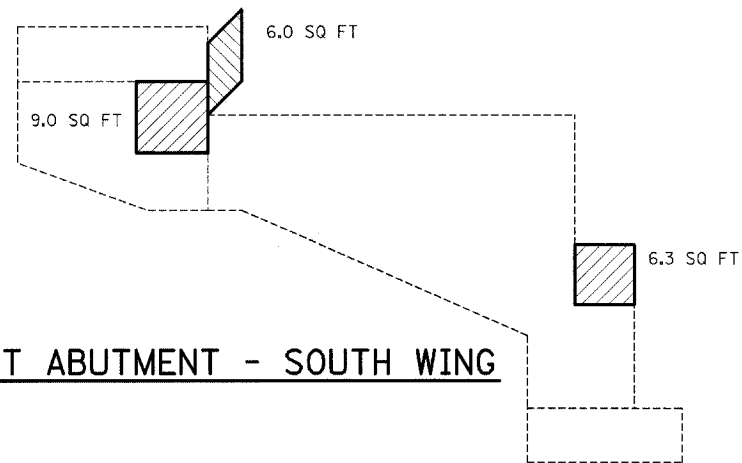

WEST ABUTMENT - SOUTH WING

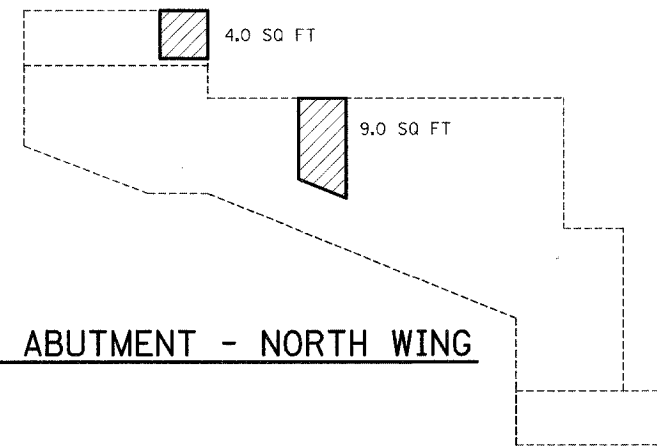

EAST ABUTMENT - NORTH WING

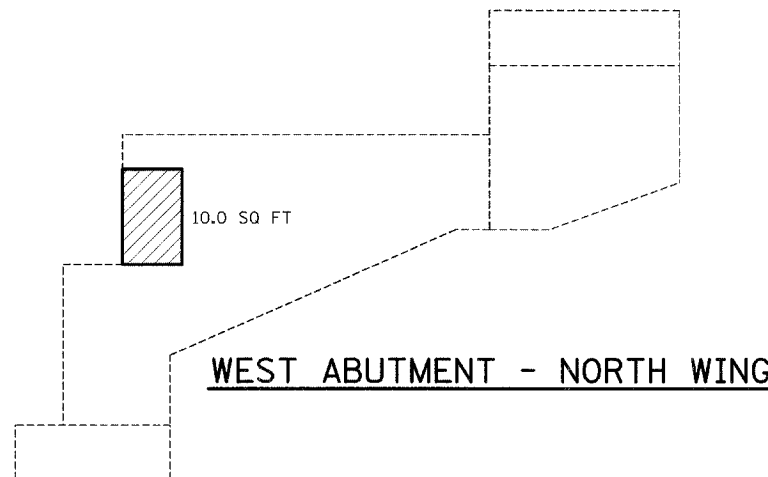

WEST ABUTMENT - NORTH WING

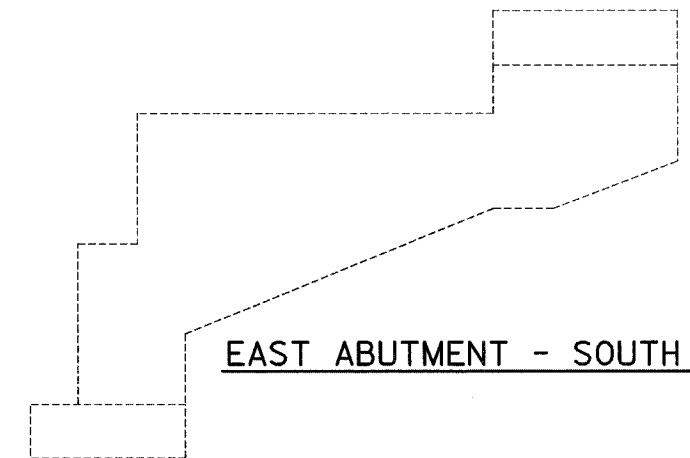

EAST ABUTMENT - SOUTH WING

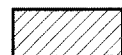

Structural Repair of Concrete (Depth < 5")

NOTE: QUANTITIES ARE ESTIMATED. ACTUAL QUANTITIES TO BE DETERMINED BY THE RESIDENT ENGINEER.

FILE NAME = c:\projects\74171d\karenbridge.dgn	USER NAME = swartzw	DESIGNED -	REVISED -
		DRAWN -	REVISED -
	PLOT SCALE = 20.0000 1 / IN.	CHECKED -	REVISED -
	PLOT DATE = 3/20/2008	DATE -	REVISED -

**STATE OF ILLINOIS
DEPARTMENT OF TRANSPORTATION**

**STRUCTURAL REPAIR - SUBSTRUCTURE
SN 058-0093 (EB)**

SCALE: N/A SHEET NO. 10 OF 52 SHEETS STA. TO STA.

F.A.I. RTE. 72	SECTION (58,74X66,67)RS-1	COUNTY MACON	TOTAL SHEETS 88	SHEET NO. 52 SHEETS
FED. ROAD DIST. NO. ILLINOIS FED. AID PROJECT			CONTRACT NO. 74	

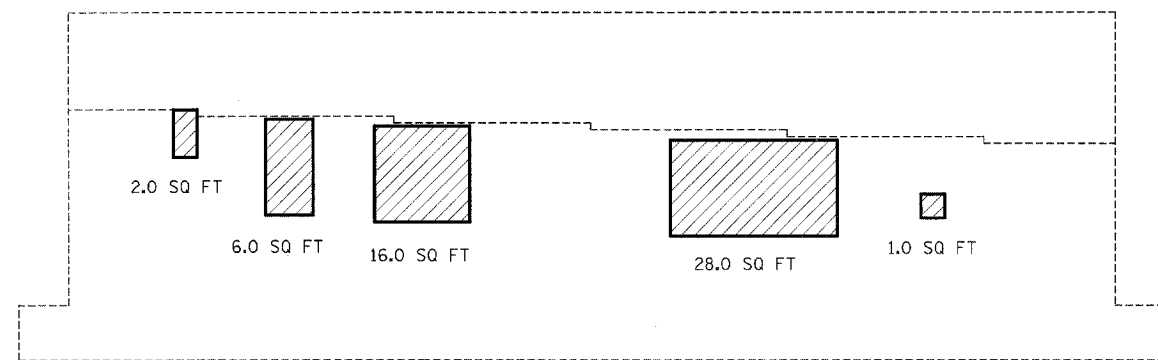

WEST ABUTMENT

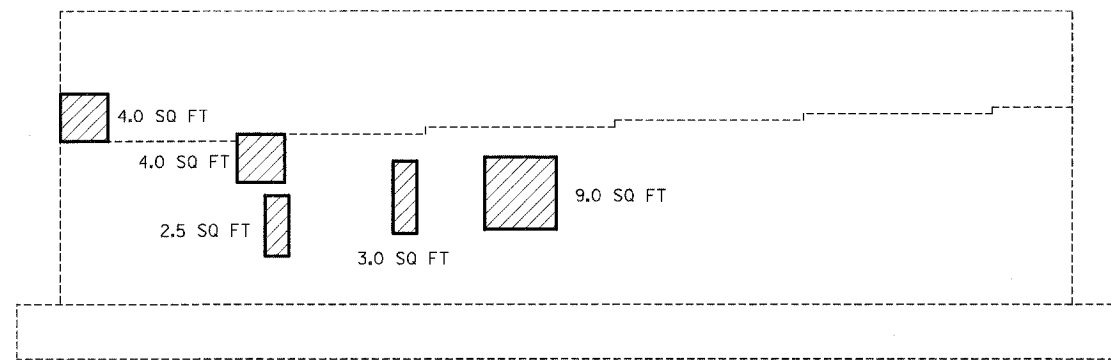

EAST ABUTMENT

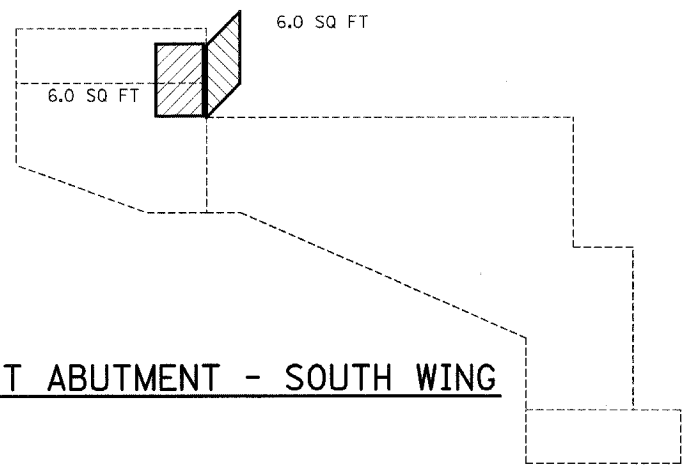

WEST ABUTMENT - SOUTH WING

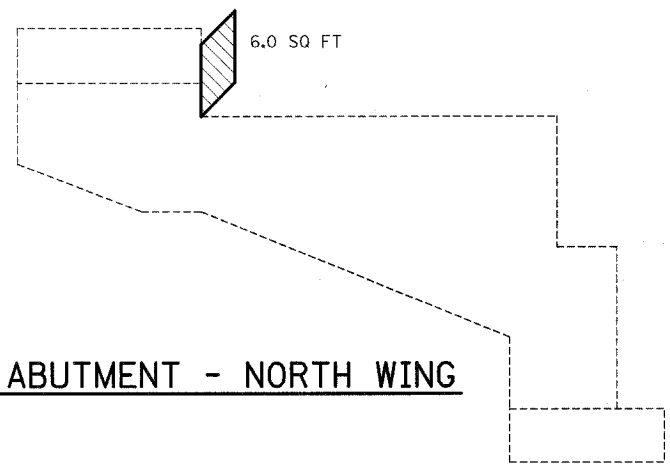

EAST ABUTMENT - NORTH WING

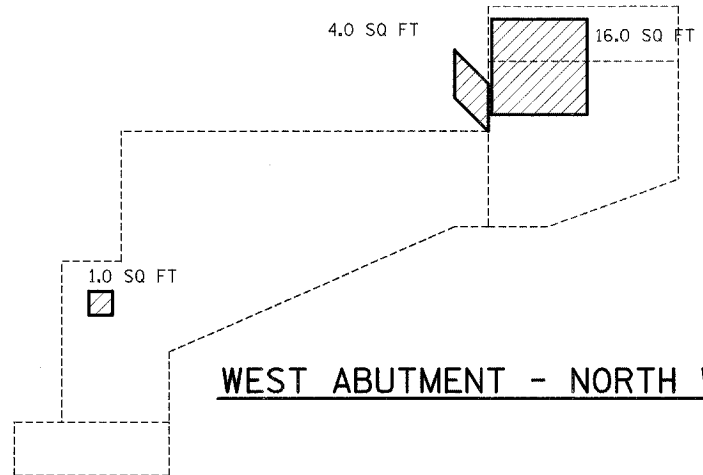

WEST ABUTMENT - NORTH WING

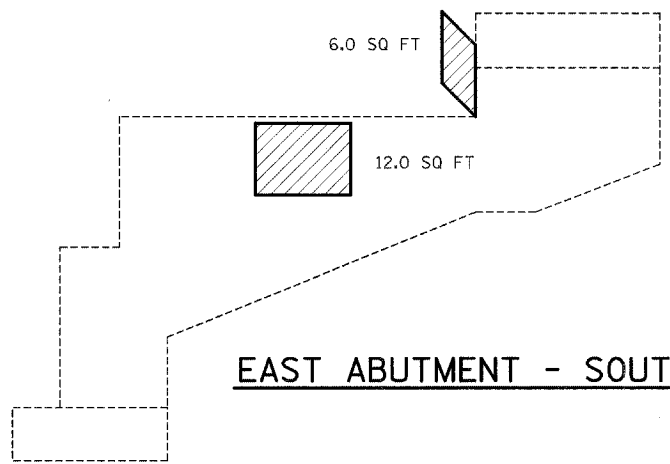

EAST ABUTMENT - SOUTH WING



Structural Repair of Concrete (Depth < 5")

NOTE: QUANTITIES ARE ESTIMATED. ACTUAL QUANTITIES TO BE DETERMINED BY THE RESIDENT ENGINEER.

FILE NAME = c:\projects\74171d\karenbridge.dgn	USER NAME = swartzw	DESIGNED -	REVISED -
		DRAWN -	REVISED -
	PLOT SCALE = 20,0000' / IN.	CHECKED -	REVISED -
	PLOT DATE = 3/28/2008	DATE -	REVISED -

**STATE OF ILLINOIS
DEPARTMENT OF TRANSPORTATION**

STRUCTURAL REPAIR - SUBSTRUCTURE 058-0094 (WB)	
SCALE: N/A	SHEET NO. 11 OF 52 SHEETS STA. TO STA.

F.A.I. RTE. 72	SECTION (58,74X66,67)RS-1	COUNTY MACON	TOTAL SHEETS 88	SHEET NO. 52
FED. ROAD DIST. NO. ILLINOIS FED. AID PROJECT			CONTRACT NO. 741	

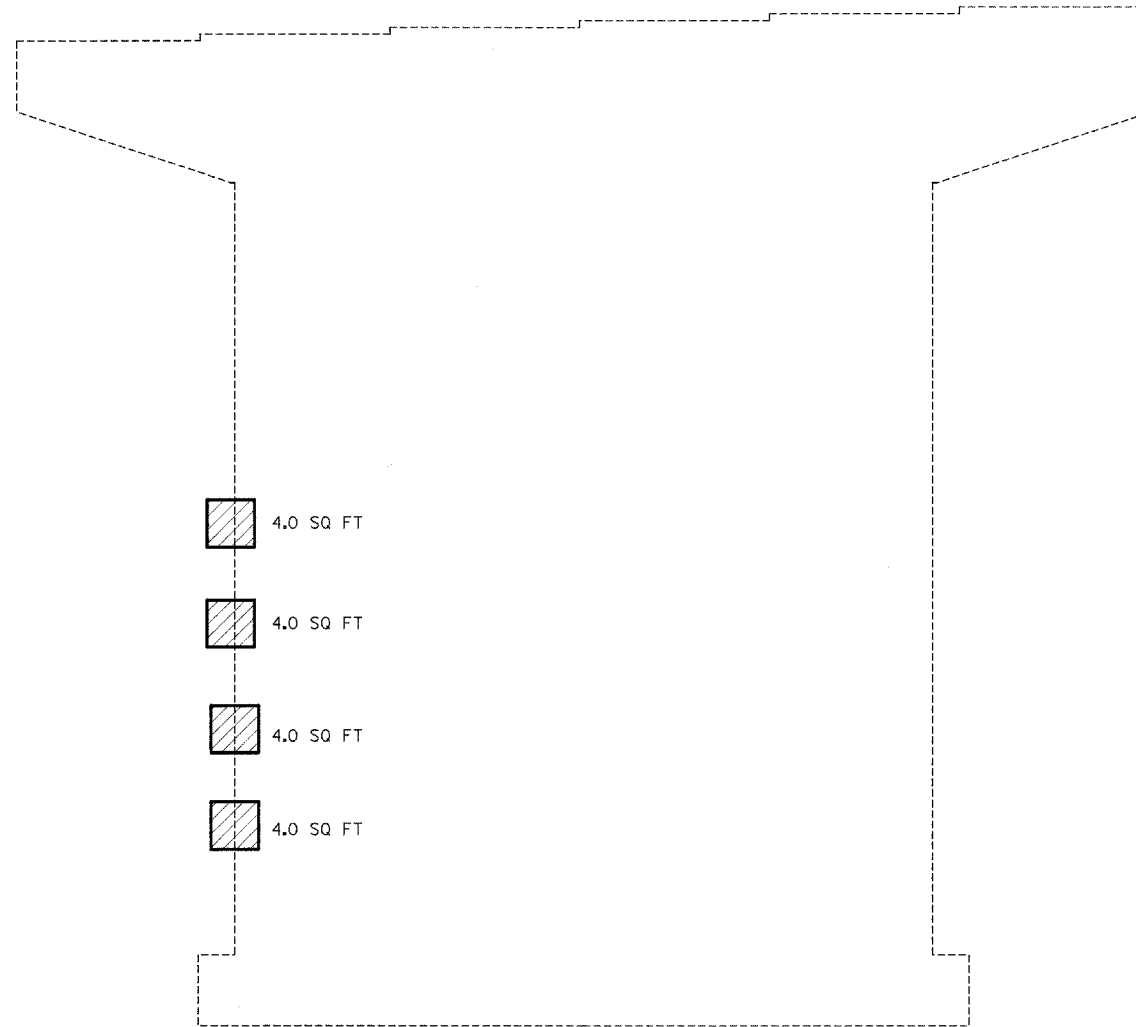

PIER #1 - WEST FACE
SN 058-0094 (WB)

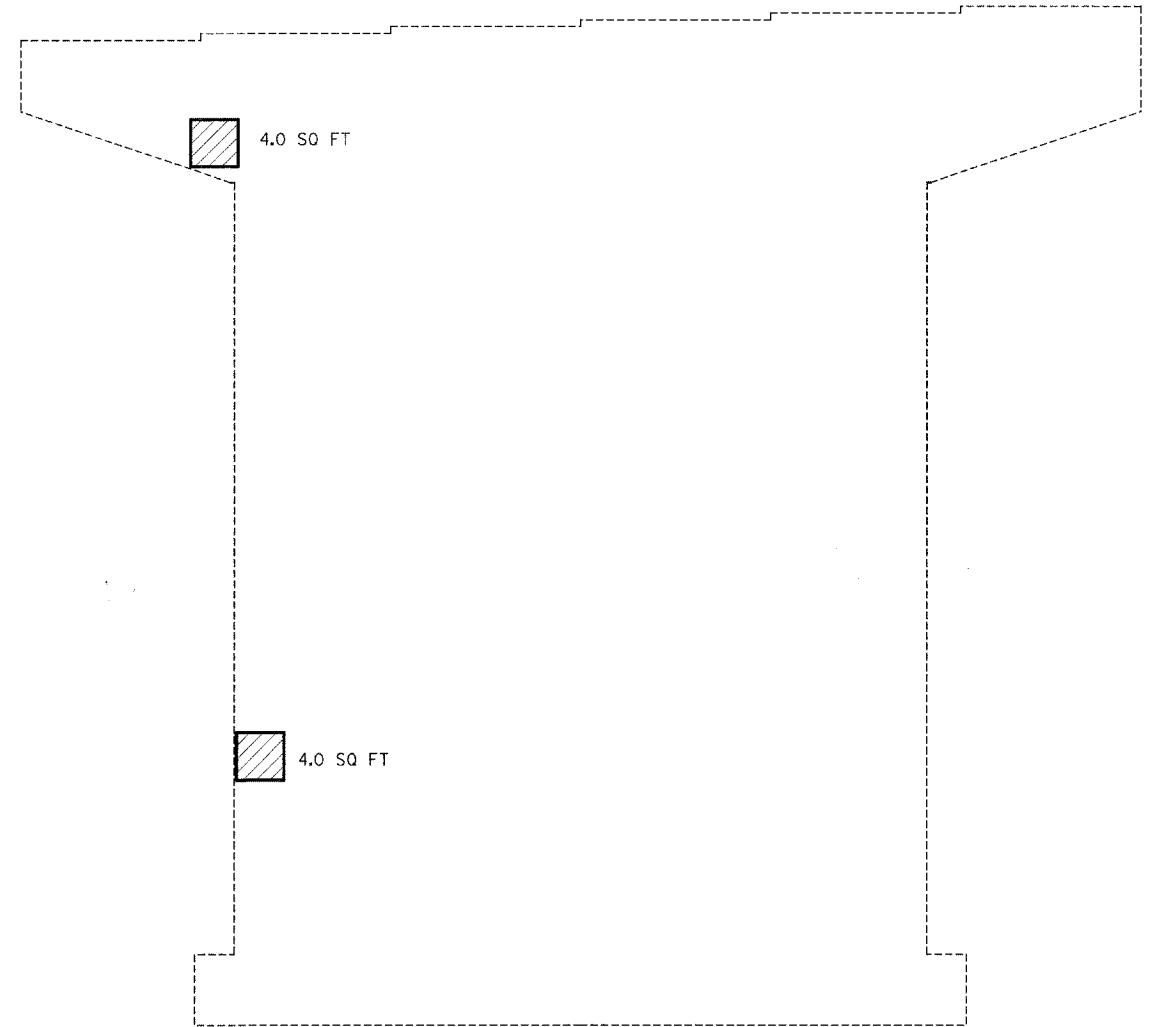

PIER #1 - WEST FACE
SN 058-0093 (EB)

NOTE: QUANTITIES ARE ESTIMATED. ACTUAL QUANTITIES TO BE DETERMINED BY THE RESIDENT ENGINEER.



Structural Repair of Concrete (Depth < 5")

FILE NAME = c:\projects\74171d\karenbr\sdge.dgn	USER NAME = swartzrw	DESIGNED -	REVISED -
		DRAWN -	REVISED -
	PLOT SCALE = 20.0000' / IN.	CHECKED -	REVISED -
	PLOT DATE = 3/20/2008	DATE -	REVISED -

**STATE OF ILLINOIS
DEPARTMENT OF TRANSPORTATION**

**STRUCTURAL REPAIR - SUBSTRUCTURE
SN 058-0093 (EB) & SN 058-0094 (WB)**

SCALE: N/A SHEET NO. 12 OF 52 SHEETS STA. TO STA.

F.A.I. RTE. 72	SECTION (58,74X66,67)RS-1	COUNTY MACON	TOTAL SHEETS 88	SHEET NO. 31
FED. ROAD DIST. NO. ILLINOIS FED. AID PROJECT			CONTRACT NO. 741	

SHEET NO.
52 SHEET

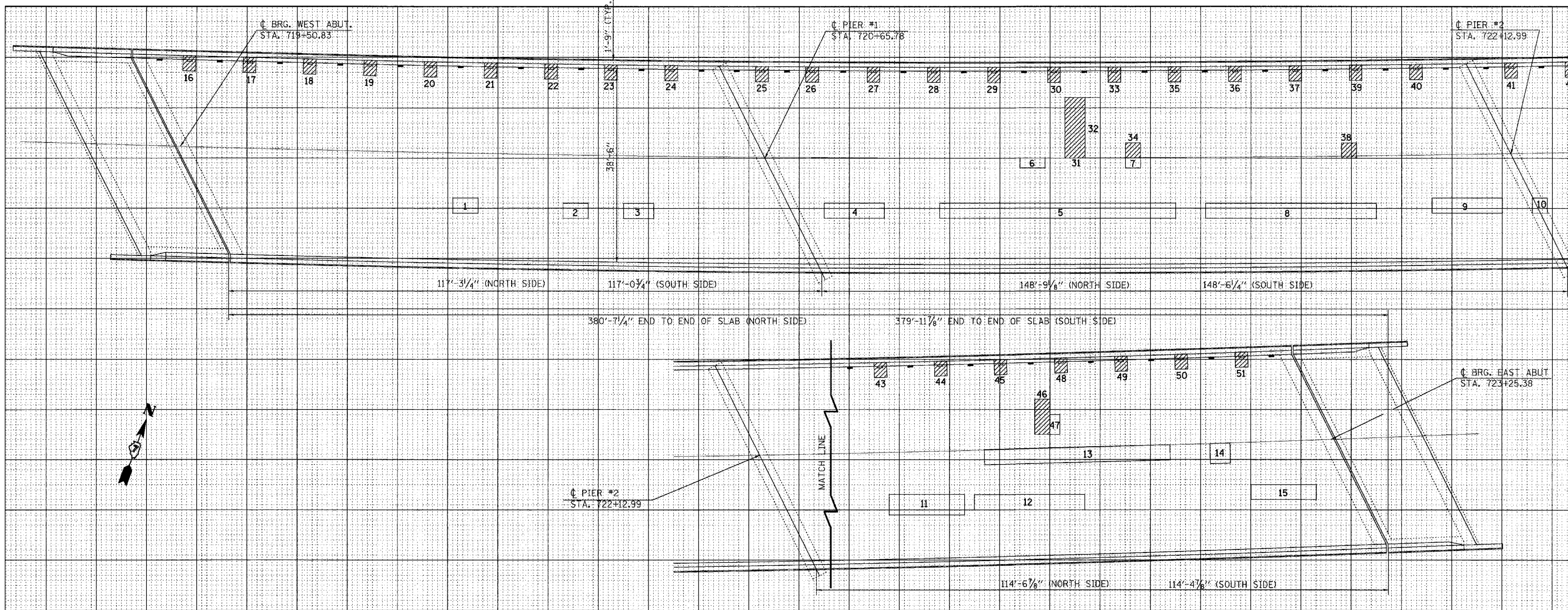

PATCH NO.	SIZE	DECK SLAB REPAIR (PART DEPTH)		
		SQ FT	SQ FT	SQ FT
1	5.0 x 3.0	15.0		
2	5.0 x 3.0	15.0		
3	6.0 x 3.0	18.0		
4	12.0 x 3.0	36.0		
5	47.0 x 3.0	141.0		
6	5.0 x 2.0	10.0		
7	3.0 x 2.0	6.0		
8	34.0 x 3.0	102.0		
9	14.0 x 3.0	42.0		
10	3.0 x 3.0	9.0		
11	15.0 x 4.0	60.0		
12	22.0 x 3.0	66.0		
13	37.0 x 3.0	111.0		
14	4.0 x 4.0			
15	13.0 x 3.0	39.0		
16	1.8 x 1.2		2.2	
17	1.8 x 1.2		2.2	
18	1.8 x 1.2		2.2	

PATCH NO.	SIZE	DECK SLAB REPAIR (PART DEPTH)		
		SQ FT	SQ FT	SQ FT
19	1.8 x 1.2		2.2	
20	1.8 x 1.2		2.2	
21	1.8 x 1.2		2.2	
22	1.8 x 1.2		2.2	
23	1.8 x 1.2		2.2	
24	1.8 x 1.2		2.2	
25	1.8 x 1.2		2.2	
26	1.8 x 1.2		2.2	
27	1.8 x 1.2		2.2	
28	1.8 x 1.2		2.2	
29	1.8 x 1.2		2.2	
30	1.8 x 1.2		2.2	
31	4.0 x 12.0			48.0
32	3.0 x 12.0	36.0		
33	1.8 x 1.2		2.2	
34	3.0 x 3.0			9.0
35	1.8 x 1.2		2.2	
36	1.8 x 1.2		2.2	

PATCH NO.	SIZE	DECK SLAB REPAIR (PART DEPTH)		
		SQ FT	SQ FT	SQ FT
37	1.8 x 1.2		2.2	
38	3.0 x 3.0			9.0
39	1.8 x 1.2		2.2	
40	1.8 x 1.2		2.2	
41	1.8 x 1.2		2.2	
42	1.8 x 1.2		2.2	
43	1.8 x 1.2		2.2	
44	1.8 x 1.2		2.2	
45	1.8 x 1.2		2.2	
46	3.0 x 7.0			21.0
47	2.0 x 4.0	8.0		
48	1.8 x 1.2		2.2	
49	1.8 x 1.2		2.2	
50	1.8 x 1.2		2.2	
51	1.8 x 1.2		2.2	
TOTAL		714	66	87

PATCH NO.	SIZE	DECK SLAB REPAIR (PART DEPTH)		
		SQ FT	SQ FT	SQ FT
	PARTIAL DEPTH			
	714 / 9 = 79.3			
	USE	79	SQ YD	
	FULL DEPTH, TYPE 1			
	66 / 9 = 7.3			
	USE	7	SQ YD	
	FULL DEPTH, TYPE 2			
	87 / 9 = 9.7			
	USE	10	SQ YD	

PATCH NO.	SIZE	DECK SLAB REPAIR (PART DEPTH)		
		SQ FT	SQ FT	SQ FT

THE LOCATIONS AND SIZES SHOWN GRAPHICALLY ABOVE ARE APPROXIMATE. SEE THE TABLE FOR ACTUAL SIZES.

- PATCHING LEGEND
- [] PARTIAL DEPTH (FOR INFORMATION ONLY)
 - [/] FULL DEPTH
 - [] FLOOR DRAIN TO BE REPLACED
 - [] FLOOR DRAIN TO BE PLUGGED

DATE OF SURVEY: 10/31/0 SURVEY BY: M. ALLEN, K. TH METHOD OF SURVEY: VISUA

BRIDGE DECK PATCHING
MACON COUNTY

SHEET NO. 13
52 SHEETS

093

FILE NAME = c:\projects\bridges\brmacon.dgn

USER NAME = smartz
PLOT SCALE = 50.0000' / 1".
PLOT DATE = 3/20/2008

DESIGNED -
DRAWN -
CHECKED -
DATE -

REVISED -
REVISED -
REVISED -
REVISED -

STATE OF ILLINOIS
DEPARTMENT OF TRANSPORTATION

DECK SLAB REPAIR
S.N. 058-0093 (E.B.)
SCALE: 50 SHEET NO. 13 OF 44 SHEETS STA. TO STA.

F-A-I RTE.	SECTION	COUNTY	TOTAL SHEETS
72	(58,74)(66,67)RS-1	MACON	78
			CONTRACT NO. 74
	FED. ROAD DIST. NO.	[ILLINOIS] FED. AID PROJECT	

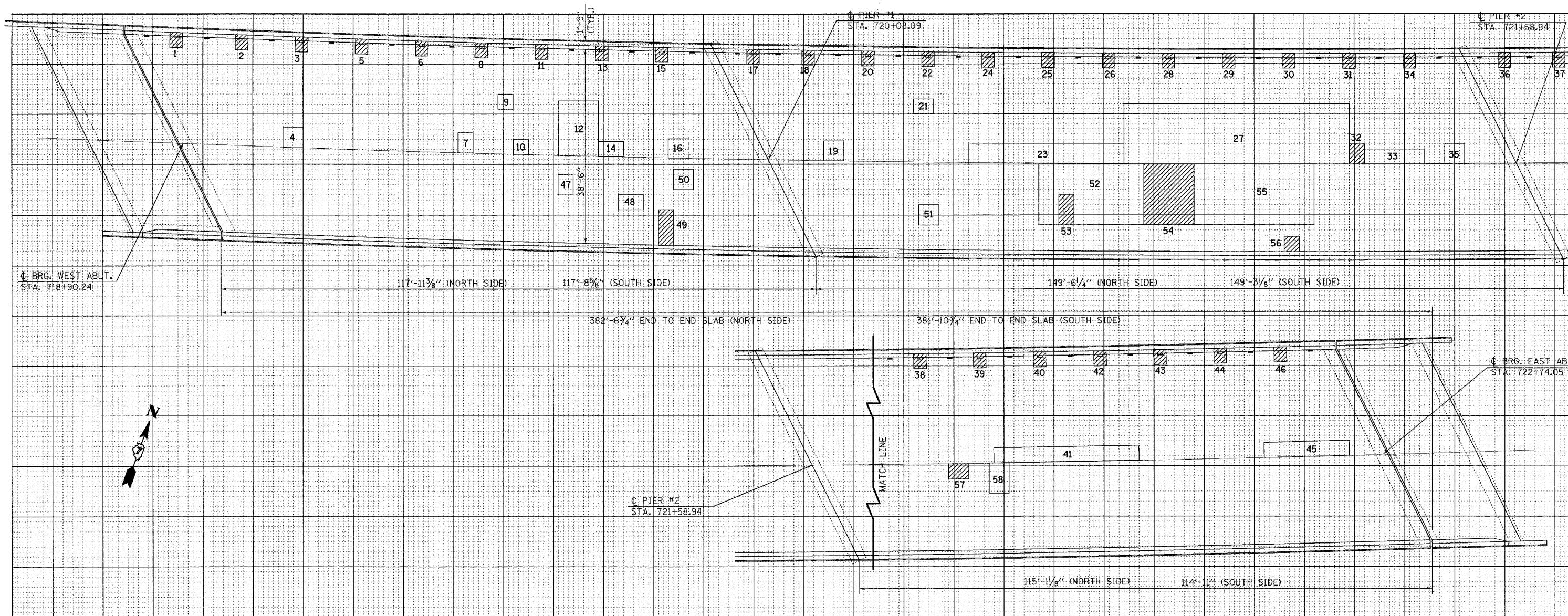

PATCH NO.	SIZE	DECK SLAB REPAIR (PART DEPTH)		
		SQ FT	SQ FT	SQ FT
1	1.8 x 1.2		2.2	
2	1.8 x 1.2		2.2	
3	1.8 x 1.2		2.2	
4	4.0 x 4.0	16.0		
5	1.8 x 1.2		2.2	
6	1.8 x 1.2		2.2	
7	3.0 x 4.0	12.0		
8	1.8 x 1.2		2.2	
9	3.0 x 3.0	9.0		
10	3.0 x 3.0	9.0		
11	1.8 x 1.2		2.2	
12	8.0 x 11.0	88.0		
13	1.8 x 1.2		2.2	
14	5.0 x 3.0			
15	1.8 x 1.2		2.2	
16	4.0 x 4.0	16.0		
17	1.8 x 1.2		2.2	
18	1.8 x 1.2		2.2	

PATCH NO.	SIZE	DECK SLAB REPAIR (PART DEPTH)		
		SQ FT	SQ FT	SQ FT
19	4.0 x 4.0	16.0		
20	1.8 x 1.2		2.2	
21	4.0 x 3.0	12.0		
22	1.8 x 1.2		2.2	
23	31.0 x 4.0	124.0		
24	1.8 x 1.2		2.2	
25	1.8 x 1.2		2.2	
26	1.8 x 1.2		2.2	
27	45.0 x 12.0	540.0		
28	1.8 x 1.2		2.2	
29	1.8 x 1.2		2.2	
30	1.8 x 1.2		2.2	
31	1.8 x 1.2		2.2	
32	3.0 x 4.0			12.0
33	12.0 x 3.0	36.0		
34	1.8 x 1.2		2.2	
35	4.0 x 4.0	16.0		
36	1.8 x 1.2		2.2	

PATCH NO.	SIZE	DECK SLAB REPAIR (PART DEPTH)		
		SQ FT	SQ FT	SQ FT
37	1.8 x 1.2		2.2	
38	1.8 x 1.2		2.2	
39	1.8 x 1.2		2.2	
40	1.8 x 1.2		2.2	
41	29.0 x 3.0	87.0		
42	1.8 x 1.2		2.2	
43	1.8 x 1.2		2.2	
44	1.8 x 1.2		2.2	
45	17.0 x 3.0	51.0		
46	1.8 x 1.2		2.2	
47	3.0 x 4.0	12.0		
48	5.0 x 3.0	15.0		
49	3.0 x 7.0			21.0
50	4.0 x 4.0	16.0		
51	4.0 x 4.0	16.0		
52	5.0 x 12.0	60.0		
	3.0 x 6.0	18.0		
	14.0 x 12.0	168.0		

PATCH NO.	SIZE	DECK SLAB REPAIR (PART DEPTH)		
		SQ FT	SQ FT	SQ FT
53	3.0 x 6.0	18.0		
54	10.0 x 12.0			120.0
55	24.0 x 12.0	288.0		
56	3.0 x 3.0	9.0		
57	4.0 x 3.0			12.0
58	4.0 x 6.0	24.0		
	TOTAL	1676	66	165
			0	

PATCH NO.	SIZE	DECK SLAB REPAIR (PART DEPTH)		
		SQ FT	SQ FT	SQ FT
	PARTIAL DEPTH			
	1676 / 9 =	186.2		
	USE	186	SQ YD	
	FULL DEPTH, TYPE 1			
	66 / 9 =	7.3		
	USE	7	SQ YD	
	FULL DEPTH, TYPE 2			
	165 / 9 =	18.3		
	USE	18	SQ YD	

THE LOCATIONS AND SIZES SHOWN GRAPHICALLY ABOVE ARE APPROXIMATE. SEE THE TABLE FOR ACTUAL SIZES.

PATCHING LEGEND

- PARTIAL DEPTH (FOR INFORMATION ONLY)
- FULL DEPTH
- FLOOR DRAIN TO BE REPLACED
- FLOOR DRAIN TO BE PLUGGED

DATE OF SURVEY: 10/31/00
 SURVEY BY: M. ALLEN, K. THOMAS
 METHOD OF SURVEY: VISUAL

BRIDGE DECK PATCHING
 MACON COUNTY

SHEET NO 14
 52 SHEETS

094

FILE NAME = c:\projects\bridges\brmacon\dgn	USER NAME = swartzk	DESIGNED -	REVISED -	STATE OF ILLINOIS DEPARTMENT OF TRANSPORTATION	DECK SLAB REPAIR S.N. 058-0094 (W.B.)	F.A.I. RTE. 72	SECTION (58,74)(66,67)RS-1	COUNTY MACON	TOTAL SHEETS 78	
PLOT SCALE = 50,0000' / IN.	CHECKED -	REVISOR -	SCALE: 50			SHEET NO. 14 OF 44 SHEETS	STA. TO STA.	FED. ROAD DIST. NO.	ILLINOIS FED. AID PROJECT	CONTRACT NO. 74
PLOT DATE = 3/20/2008	DATE -	REVISOR -								

BRIDGE DECK PATCHING

STATE OF ILLINOIS
DEPARTMENT OF TRANSPORTATION

ROUTE NO.	SECTION	COUNTY	TOTAL SHEETS	SHEET NO.	SHEET NO. 1
FAI 72		MACON	88	40	3 SHEETS
FED. ROAD DIST. NO. 7	ILLINOIS	FED. AID PROJECT			

Contract Number: 74171

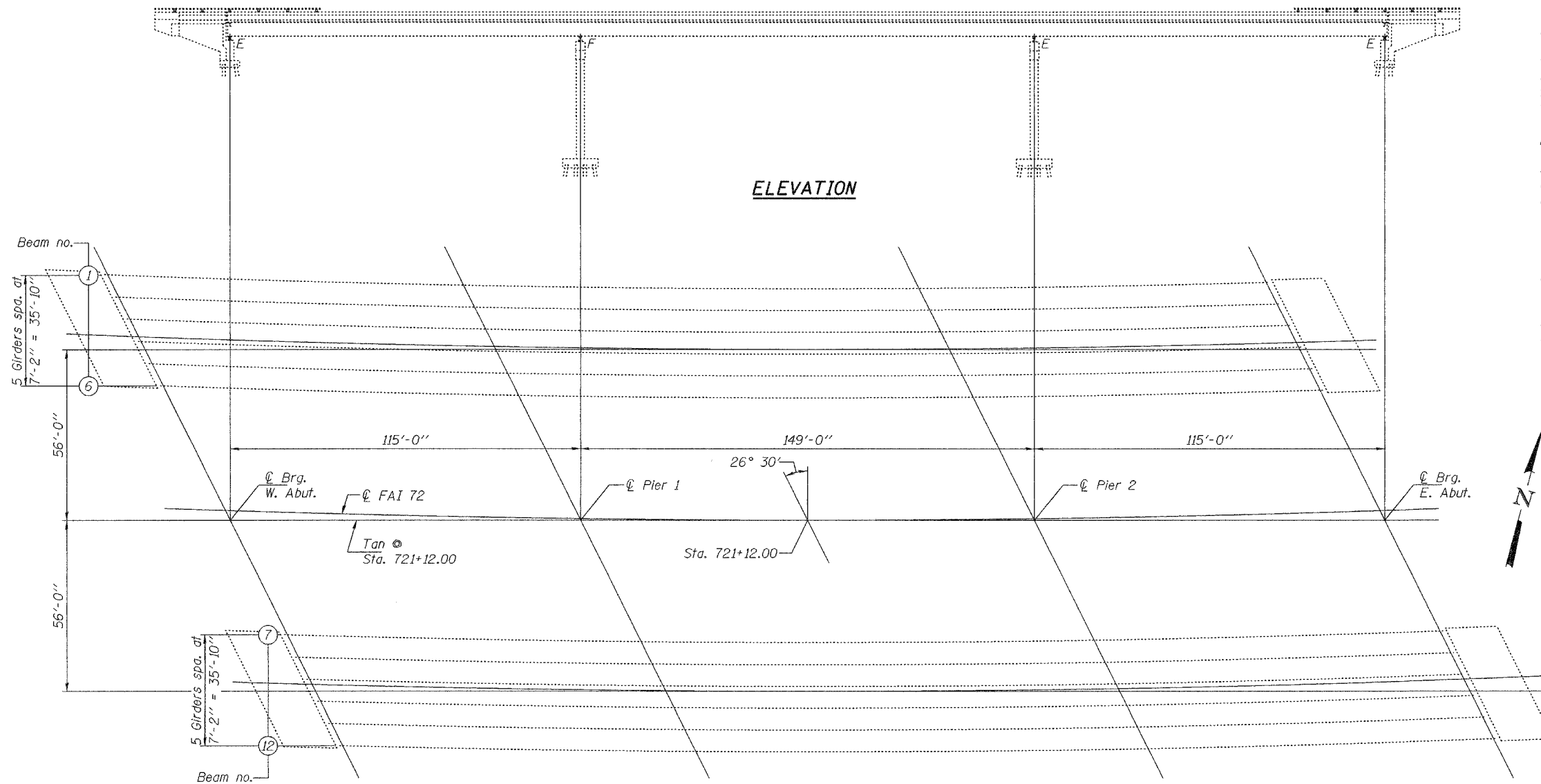

ELEVATION

PLAN

Remove and replace bearings at abutments.

NOTES

All structural steel shall conform to AASHTO Classification M-270 Gr. 36, unless otherwise noted.

Plan dimensions and details relative to existing plans are subject to routine variations. The Contractor shall field verify existing dimensions and details affecting new construction and make necessary approved adjustments prior to construction or ordering of materials. Such variations shall not be cause for additional compensation for a change in scope of the work, however, the Contractor will be paid for the quantity actually furnished based upon the unit price bid for the work.

If the analysis submitted to the Contractor for the jacking/temporary support system to be used shows temporary stiffeners are required to prevent web crippling or buckling, the stiffeners shall be steel and bolted to the web. If stiffeners are not required, hardwood timbers shall be installed tightly between the top and bottom flange to prevent flange rotation.

The existing structural steel coating contains lead. The Contractor shall take appropriate precautions to deal with the presence of lead on this project.

Existing structural steel that will be in contact with new structural steel shall be cleaned and painted prior to erection as required by the Special Provision "Cleaning and Painting Contact Surface Areas of Existing Steel Structures".

All structural steel shall be shop painted with the inorganic zinc rich primer per AASHTO M300, Type 1. Cost included with Furnishing and Erecting Structural Steel.

BILL OF MATERIAL

ITEM	UNIT	TOTAL
Furnishing and Erecting Structural Steel	Pound	4710
Anchor Bolt 1"φ	Each	96
Elastomeric Bearing Assembly, Type I	Each	12
Elastomeric Bearing Assembly, Type II	Each	12
Jack and Remove Existing Bearings	Each	24

DESIGNED	<i>[Signature]</i>
CHECKED	<i>[Signature]</i>
DRAWN	ballva
CHECKED	ASB 5/8

APRIL 18, 2008
EXAMINED *[Signature]*
ENGINEER OF STRUCTURAL SERVICES
PASSED *[Signature]*
ENGINEER OF BRIDGES AND STRUCTURES



EXPIRES 11-30-2008

BEARING REPLACEMENT PLAN AND ELEVATION
FAI RT. 72 OVER FRIENDS CREEK
MACON COUNTY
SN 058-0093 & 0094

STATE OF ILLINOIS
DEPARTMENT OF TRANSPORTATION

ROUTE NO.	SECTION	COUNTY	DIST.	SHEET NO.
FAI 72		MACON	88	41
FED. ROAD DIST. NO. 7		ILLINOIS		FED. AID PROJECT-

SHEET NO. 2
3 SHEETS

Contract Number: 74171

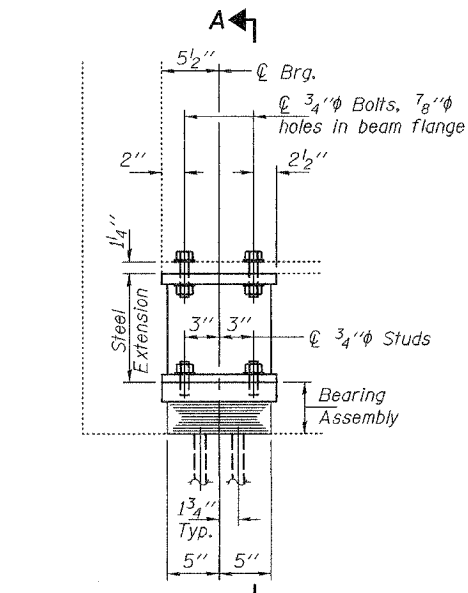

ELEVATION AT W. ABUTMENT

TYPE I ELASTOMERIC EXP. BRG.

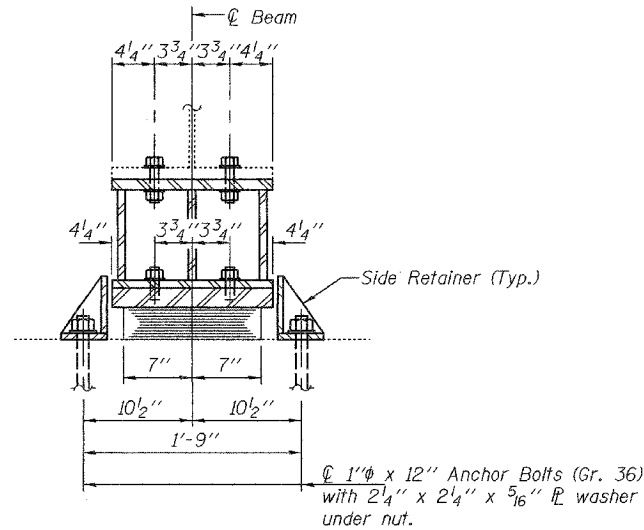

SECTION A-A

BEAM REACTIONS

R _D	(K)	57.2
R _L	(K)	42.4
Imp.	(K)	8.9
R (Total)	(K)	108.5

Notes:

Diaphragm removal and reinstallation may be required to facilitate drilling holes. Cost included with Furnishing and Erecting Structural Steel.
New steel extensions, shim plates and connection bolts are included with Furnishing and Erecting Structural Steel. Prior to ordering any material, the Contractor shall verify in the field all bearing height and shim thickness dimensions. Min. jack capacity = 65 Tons.
Anchor bolts shall be ASTM F1554 all-thread (or an Engineer-approved alternate material) of the grade(s) and diameter(s) specified. ASTM A307 Grade C anchor bolts may be used in lieu of ASTM F1554 Grade 36 (F_y=36ksi). The corresponding specified grade of AASHTO M314 anchor bolts may be used in lieu of ASTM F1554.
Drilled and set anchor bolts shall be installed according to Article 521.06 of the Standard Specifications. Side retainers shall be included in the cost of Elastomeric Bearing Assembly, Type I.

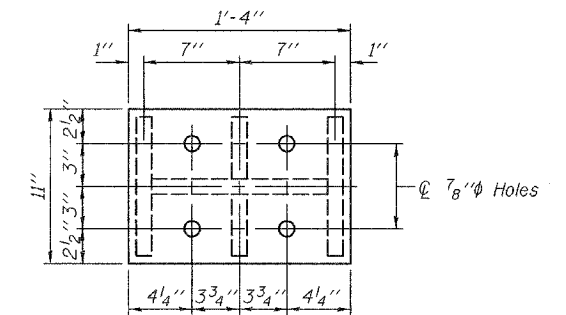

PLAN TOP AND BOTTOM PLATE

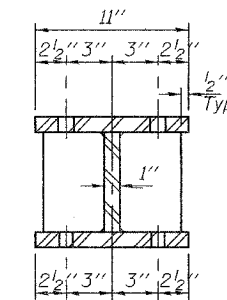

SECTION B-B

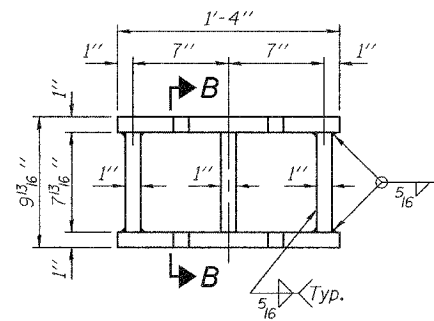

STEEL EXTENSION DETAIL

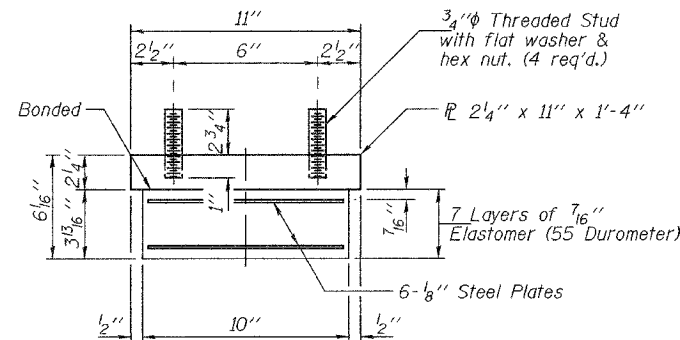

BEARING ASSEMBLY

Note:
Shim plates shall not be placed under Bearing Assembly.

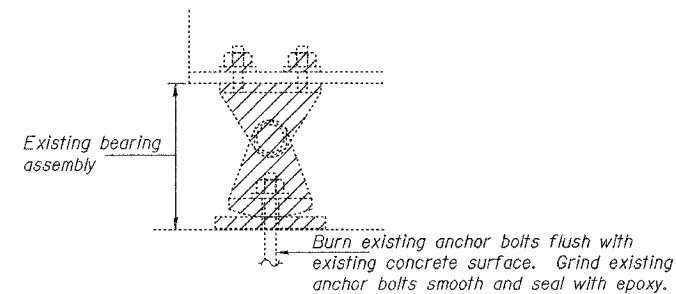

EXISTING BEARING REMOVAL DETAIL

Cost included with Jack and Remove Existing Bearings.

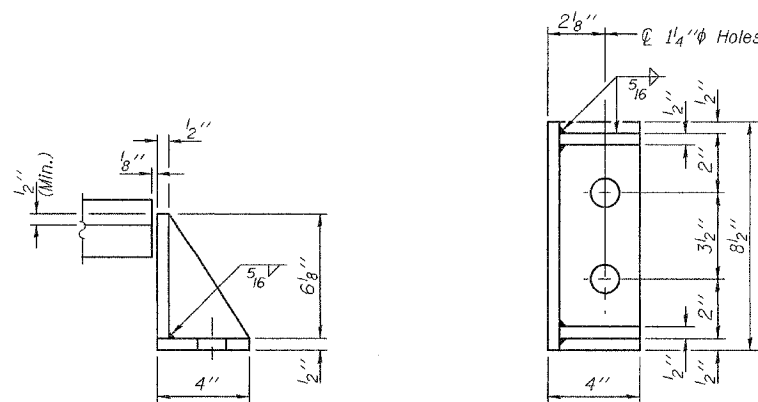

SIDE RETAINER

Equivalent rolled angle with stiffeners will be allowed in lieu of welded plates.

BILL OF MATERIAL

Item	Unit	Total
Elastomeric Bearing Assembly Type I	Each	12
Jack and Remove Existing Bearings	Each	12
Furnishing and Erecting Structural Steel	Pound	2380
Anchor Bolt 1"φ	Each	48

WEST ABUTMENT BEARING
REPLACEMENT DETAILS
FAI RT. 72 OVER FRIENDS CREEK
MACON COUNTY
SN 058-0093 & 0094

DESIGNED	AJB
CHECKED	SJB
DRAWN	balliva
CHECKED	AJB SJB

APRIL 18, 2008
EXAMINED *Carl Kreyer*
ENGINEER OF STRUCTURAL SERVICES
PASSED *Ralph E. Anderson*
ENGINEER OF BRIDGES AND STRUCTURES

TYI/REPS 11-01-2006

STATE OF ILLINOIS
DEPARTMENT OF TRANSPORTATION

ROUTE NO.	SECTION	COUNTY	SHEET	SHEET NO. 3
FAI 72		MACON	88	42
FED. ROAD DIST. NO. 7	ILLINOIS	FED. AID PROJECT-		3 SHEETS

Contract Number: 74171

BEAM REACTIONS

R _P	(K)	55.4
R _T	(K)	42.3
Imp.	(K)	8.9
R (Total)	(K)	106.6

Notes:
Diaphragm removal and reinstallation may be required to facilitate drilling holes. Cost included with Furnishing and Erecting Structural Steel.
New steel extensions, shim plates and connection bolts are included with Furnishing and Erecting Structural Steel.
Prior to ordering any material, the Contractor shall verify in the field all bearing height and shim thickness dimensions. Min. jack capacity = 65 Tons.
Anchor bolts shall be ASTM F1554 all-thread (or an Engineer-approved alternate material) of the grade(s) and diameter(s) specified. ASTM A307 Grade C anchor bolts may be used in lieu of ASTM F1554 Grade 36 (F_y=36ksi). The corresponding specified grade of AASHTO M314 anchor bolts may be used in lieu of ASTM F1554.
Anchor bolts for Type II bearings shall be placed in holes drilled through the bottom bearing plate after members are in place. Side retainers shall be placed after bolts are installed.
Drilled and set anchor bolts shall be installed according to Article 521.06 of the Standard Specifications.
Side retainers shall be included in the cost of Elastomeric Bearing Assembly, Type II.
The 1/8" TFE sheet shall be bonded directly to the top steel plate with a two-component, medium viscosity epoxy resin, conforming to the requirements of the Federal Specification MMM-A-134, Type I. The bond agent shall be applied on the full area of the contact surfaces.
Bonding of 1/8" TFE sheet during vulcanizing process will be permitted provided the process and method of adjusting assembly height is approved by the Engineer.

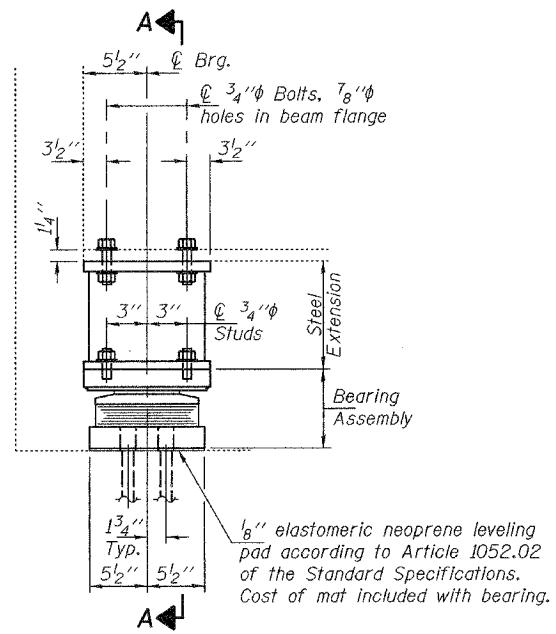

ELEVATION AT E. ABUTMENT

TYPE II TFE ELASTOMERIC EXP. BRG.

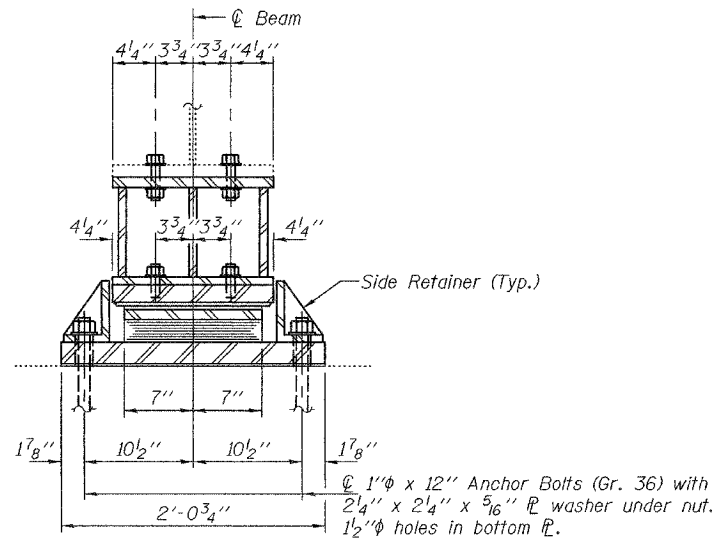

SECTION A-A

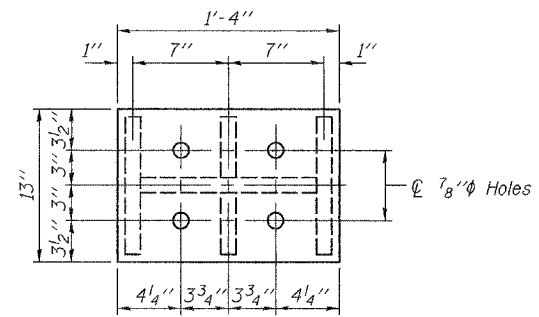

PLAN TOP AND BOTTOM PLATE

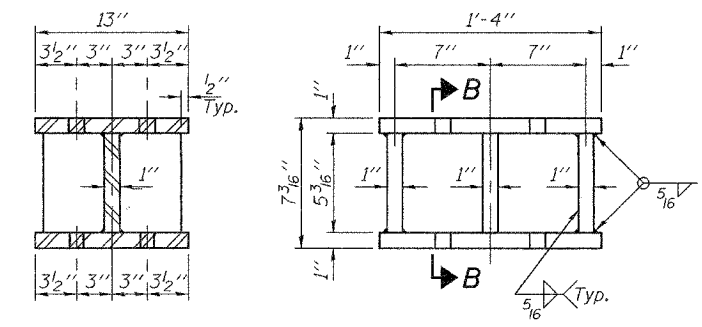

STEEL EXTENSION DETAIL

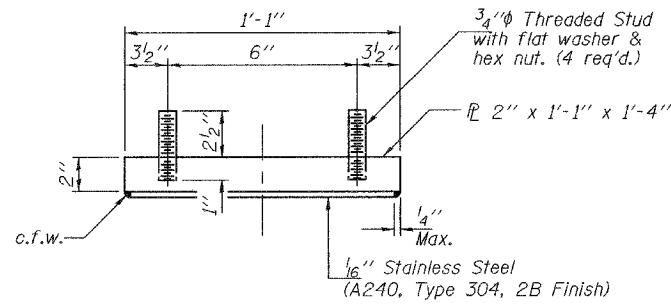

TOP BEARING ASSEMBLY

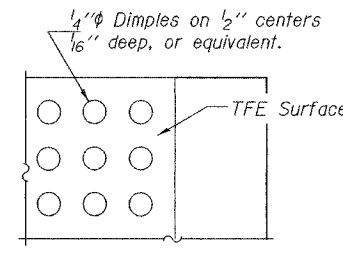

PLAN-TFE SURFACE

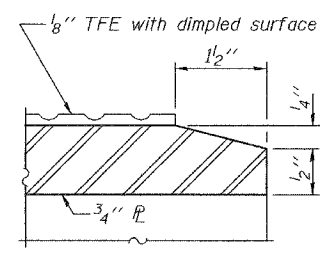

SECTION THRU TFE

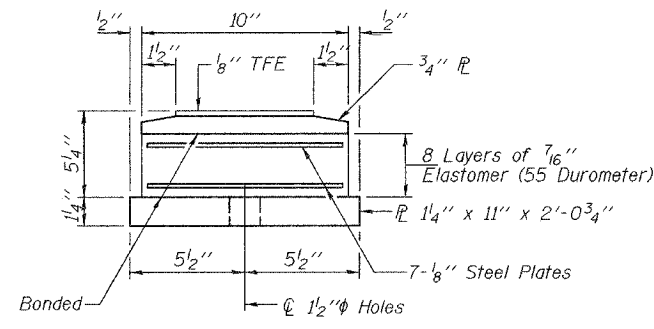

BOTTOM BEARING ASSEMBLY

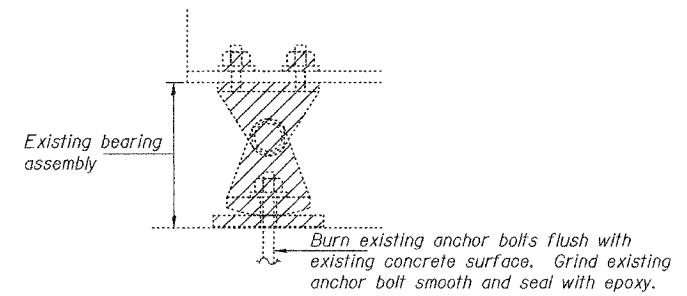

EXISTING BEARING REMOVAL DETAIL

Cost included with Jack and Remove Existing Bearings.

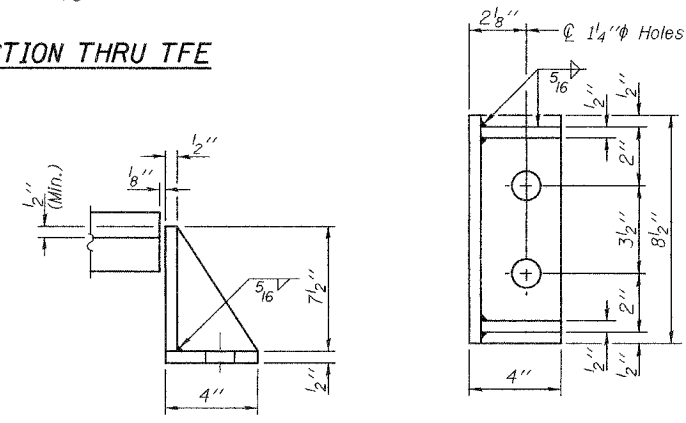

SIDE RETAINER

Equivalent rolled angle with stiffeners will be allowed in lieu of welded plates.

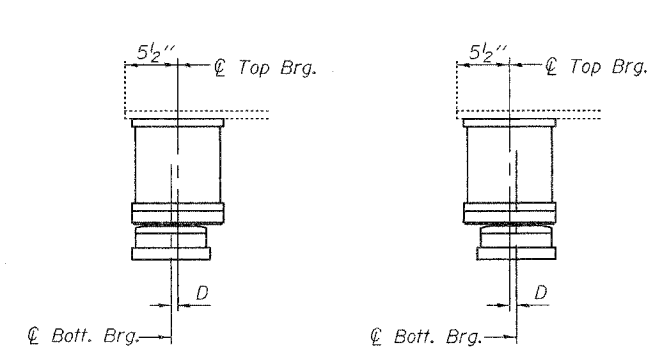

BELOW 50° F. (Move bott. brg. away from fixed brg.) ABOVE 50° F. (Move bott. brg. toward fixed brg.)

SETTING ANCHOR BOLTS AT EXP. BRG.

D = 1/8" per each 100' of expansion for every 15° temp. change from the normal temp. of 50°F.

BILL OF MATERIAL

Item	Unit	Total
Elastomeric Bearing Assembly Type II	Each	12
Jack and Remove Existing Bearings	Each	12
Furnishing and Erecting Structural Steel	Pound	2330
Anchor Bolt 1"φ	Each	48

EAST ABUTMENT BEARING REPLACEMENT DETAILS
FAI RT. 72 OVER FRIENDS CREEK
MACON COUNTY
SN 058-0093 & 0094

DESIGNED	AJB
CHECKED	SJB
DRAWN	baliva
CHECKED	AJB SJB

APRIL 18, 2008
EXAMINED *Carl Perry*
ENGINEER OF STRUCTURAL SERVICES
PASSED *Ralph E. Anderson*
ENGINEER OF BRIDGES AND STRUCTURES

TYII/REPS 11-01-2006

GENERAL NOTES

Reinforcement bars shall conform to the requirements of ASTM A 706 Br 60 (IL Modified). See Special Provisions.

Reinforcement bars designated (E) shall be epoxy coated.

Plan dimensions and details relative to existing plans are subject to routine variations. The Contractor shall field verify existing dimensions and details affecting new construction and make necessary approved adjustments prior to construction or ordering of materials. Such variations shall not be cause for additional compensations for a change in scope of the work; however, the Contractor will be paid for the quantity actually furnished based upon the unit price bid for the work.

Existing reinforcement bars extending into the removal area shall be cleaned, straightened and incorporated into the new construction. Any reinforcement bars that are damaged during concrete removal operations shall be repaired or replaced using an approved bar splicer or anchorage system. Cost included in concrete removal.

Joint openings shall be adjusted according to Article 520.04 of the Standard Specifications when the deck is poured at an ambient temperature other than 50°F.

Prior to pouring the new concrete deck, all heavy or loose rust, loose mill scale, and other loose or potentially detrimental foreign material shall be removed from the surfaces in contact with concrete. Tightly adhered paint may remain unless otherwise noted. Removal shall be accomplished by methods that will not damage the steel and the cost will be included in the pay item covering removal of the existing concrete.

Removal and replacement of the end handrail sections and support posts at both abutments of both structures will be necessary for construction of the expansion joints. The existing handrail sections and support posts shall be reused. New bolts, shim plates, and post support anchor assemblies as detailed in the plans are to be provided and installed for the replacement of the handrail and supports. This work and all materials shall be included in the contract unit price for Concrete Superstructure.

Areas of deck repairs shown are estimated. The Engineer shall show actual locations of deck repairs on as-built plans.

The existing waterproofing membrane system is not known to contain asbestos.

Construction of a Bridge Approach Wingwall Improvement at locations specified on the plans will be necessary prior to erecting the new guardrail. The end of the existing aluminum railing shall be cut as shown in the details and removed prior to placement of the new concrete. This work and all materials shall be included in the contract unit price for Concrete Superstructure.

Removal and reinstallation of the existing name plates on both structures will necessary for construction of the expansion joints. This work and all materials shall be included in the contract unit price for Relocating Name Plates.

TOTAL BILL OF MATERIALS

SN 058-0095 (EB)

ITEM DESCRIPTION	UNIT	QUANTITY
Concrete Removal	Cu. Yd.	49.2
Concrete Superstructure	Cu. Yd.	55.3
Reinforcement Bars, Epoxy Coated	Pound	7040
Bar Splicers	Each	72
Elastomeric Bearing Assembly Type II	Each	12
Furnishing and Erecting Structural Steel	Pound	1710
Jack and Remove Existing Bearings	Each	12
Hot Mix Asphalt Removal (Deck)	Sq. Yd.	1506
Bridge Deck Hydro-Scarification, 1/2"	Sq. Yd.	1506
Bridge Deck Microsilica Concrete Overlay, 2 1/4"	Sq. Yd.	1506
Bridge Deck Grooving	Sq. Yd.	1506
Protective Coat	Sq. Yd.	1506
Deck Slab Repair (Full Depth Type I)	Sq. Yd.	10
Deck Slab Repair (Full Depth Type II)	Sq. Yd.	26
Floor Drains	Each	40
Preformed Joint Strip Seal	Foot	192
Structural Repair of Concrete <5"	Sq. Ft.	266
Relocating Name Plates	Each	1
Plug Existing Deck Drains	Each	46
Anchor Bolts 1" Ø	Each	24
Protective Shield	Sq. Yd.	1124

TOTAL BILL OF MATERIALS

SN 058-0096 (WB)

ITEM DESCRIPTION	UNIT	QUANTITY
Concrete Removal	Cu. Yd.	53.3
Concrete Superstructure	Cu. Yd.	59.4
Reinforcement Bars, Epoxy Coated	Pound	7040
Bar Splicers	Each	72
Elastomeric Bearing Assembly Type II	Each	12
Furnishing and Erecting Structural Steel	Pound	1710
Jack and Remove Existing Bearings	Each	12
Bituminous Concrete Removal (Deck)	Sq. Yd.	1506
Bridge Deck Hydro-Scarification, 1/2"	Sq. Yd.	1506
Bridge Deck Microsilica Concrete Overlay, 2 1/4"	Sq. Yd.	1506
Bridge Deck Grooving	Sq. Yd.	1506
Protective Coat	Sq. Yd.	1506
Deck Slab Repair (Full Depth Type I)	Sq. Yd.	10
Deck Slab Repair (Full Depth Type II)	Sq. Yd.	32
Floor Drains	Each	40
Preformed Joint Strip Seal	Foot	192
Structural Repair of Concrete <5"	Sq. Ft.	193
Relocating Name Plates	Each	1
Plug Existing Deck Drains	Each	46
Anchor Bolts, 1" Ø	Each	24
Protective Shield	Sq. Yd.	1124

FILE NAME = c:\projects\7417id\korenbridge.dgn	USER NAME = swartzw	DESIGNED - DRAWN -	REVISED - REVISED -
	PLOT SCALE = 28,0000' / IN.	CHECKED -	REVISED -
	PLOT DATE = 3/20/2008	DATE -	REVISED -

STATE OF ILLINOIS
DEPARTMENT OF TRANSPORTATION

BRIDGE GENERAL NOTES & BILL OF MATERIALS
SN 058-0095 (EB) & SN 058-0096 (WB)

SCALE: N/A SHEET NO. 18 OF 52 SHEETS STA. TO STA.

F.A.I. RTE.	SECTION	COUNTY	TOTAL SHEETS	SHEET NO.
72	(58,74X66,67)RS-1	MACON	88	4
FED. ROAD DIST. NO.			ILLINOIS FED. AID PROJECT	
			CONTRACT NO. 741	

SHEET NO.
52 SHEET

The existing 3 span steel mult-beam structures were constructed in 1975 as section 58-66HVB. SN 058-0095 carries FAI-72 eastbound and SN 085-0096 carries FAI-72 westbound. The proposed project consists of new expansion joints, partial and full depth deck patching, remove and replace bearings at abutments, new microsilica wearing surface, new deck drains and structural repair of concrete. A new approach pavement will be constructed on the east end of SN 058-0095 (EB).

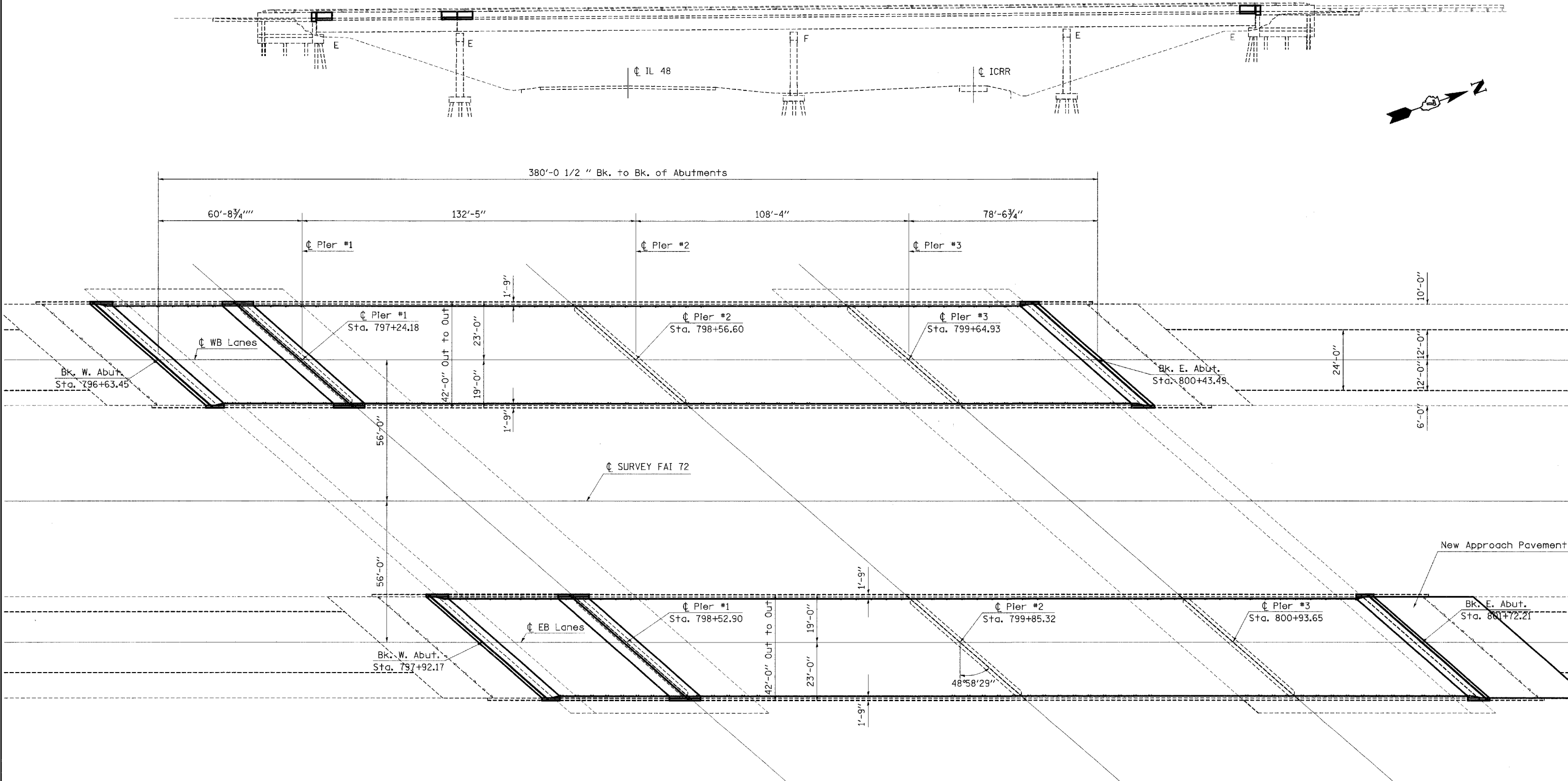

FILE NAME = c:\projects\74171d\karenbridge.dgn	USER NAME = swartzw	DESIGNED -	REVISED -
	PLLOT SCALE = 20,0000' / IN.	DRAWN -	REVISED -
	PLLOT DATE = 3/28/2008	CHECKED -	REVISED -
		DATE -	REVISED -

**STATE OF ILLINOIS
DEPARTMENT OF TRANSPORTATION**

GENERAL PLAN & ELEVATION			
SN 058-0095 (EB) & SN 058-0096 (WB)			
SCALE: N/A	SHEET NO. 19 OF 52 SHEETS	STA.	TO STA.

F.A.I. RTE. 72	SECTION (58,74X66,67)RS-1	COUNTY MACON	TOTAL SHEETS 88	SHEET NO. 52
FED. ROAD DIST. NO.	ILLINOIS FED. AID PROJECT	CONTRACT NO. 741		SH. N. 4

Note: Trim existing long. reinf. to accomodate new joint opening (typ.)

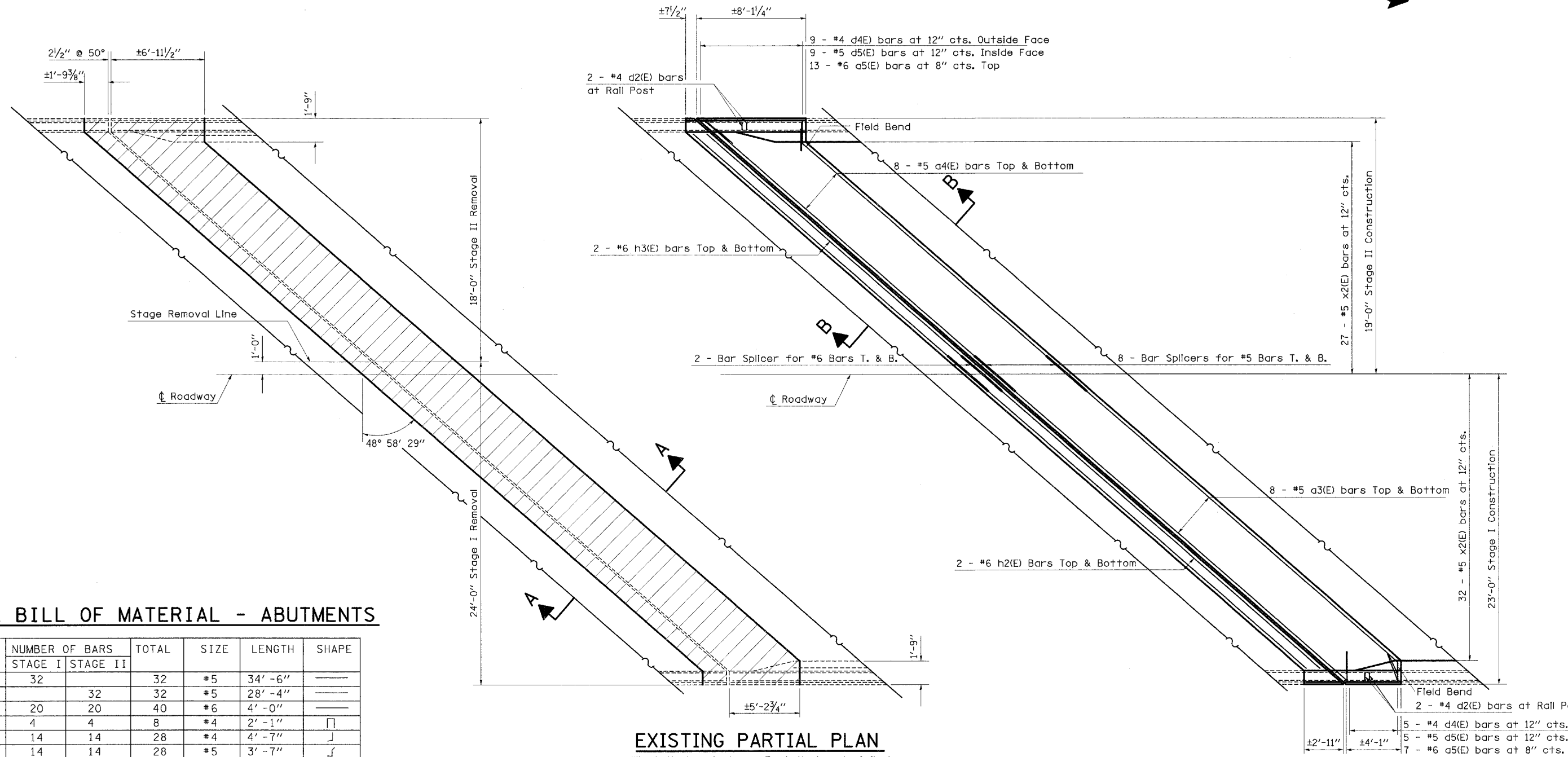
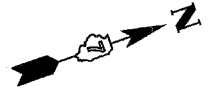

TOTAL BILL OF MATERIAL - ABUTMENTS

BAR	NUMBER OF BARS		TOTAL	SIZE	LENGTH	SHAPE
	STAGE I	STAGE II				
a3(E)	32		32	#5	34' - 6"	—
a4(E)		32	32	#5	28' - 4"	—
a5(E)	20	20	40	#6	4' - 0"	—
d2(E)	4	4	8	#4	2' - 1"	□
d4(E)	14	14	28	#4	4' - 7"	┘
d5(E)	14	14	28	#5	3' - 7"	┘
h2(E)	4	4	8	#6	33' - 0"	—
h3(E)	4	4	8	#6	26' - 10"	—
x2(E)	64	54	118	#5	4' - 6"	┘
CONCRETE REMOVAL					CU. YD.	29.9
REINFORCEMENT BARS (EPOXY COATED)					POUND	3820
CONCRETE SUPERSTRUCTURE					CU. YD.	33.1

REINFORCEMENT BARS DESIGNATED (E) SHALL BE EPOXY COATED

EXISTING PARTIAL PLAN

(West Abutment shown; East Abutment similar)

PROPOSED PARTIAL PLAN

(West Abutment shown; East Abutment similar)

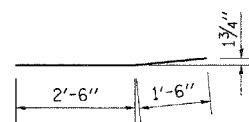

BAR a4(E)

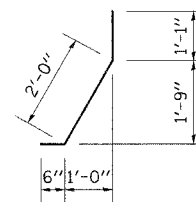

BAR d5(E)

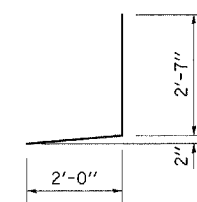

BAR d4(E)

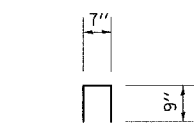

BAR d2(E)

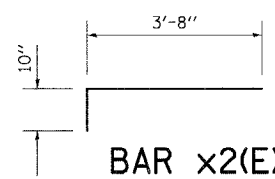

BAR x2(E)

FILE NAME = c:\projects\74171d\karenbridge.dgn	USER NAME = swartzrw	DESIGNED -	REVISED -
	PLOT SCALE = 20,0000 1/1 IN.	DRAWN -	REVISED -
	PLOT DATE = 3/28/2008	CHECKED -	REVISED -
		DATE -	REVISED -

**STATE OF ILLINOIS
DEPARTMENT OF TRANSPORTATION**

**ABUTMENT EXPANSION JOINT REPLACEMENT DETAILS
SN 058-0095 (EB)**

SCALE: N/A SHEET NO. 20 OF 52 SHEETS STA. TO STA.

F.A.I. RTE.	SECTION	COUNTY	TOTAL SHEETS	SHEET NO.
72	(58,74X66,67)RS-1	MACON	88	20
FED. ROAD DIST. NO.			ILLINOIS FED. AID PROJECT	
			CONTRACT NO. 741	

SHEET NO. 52 SHEET

Note: Trim existing long. reinf. to accommodate new joint opening (typ.)

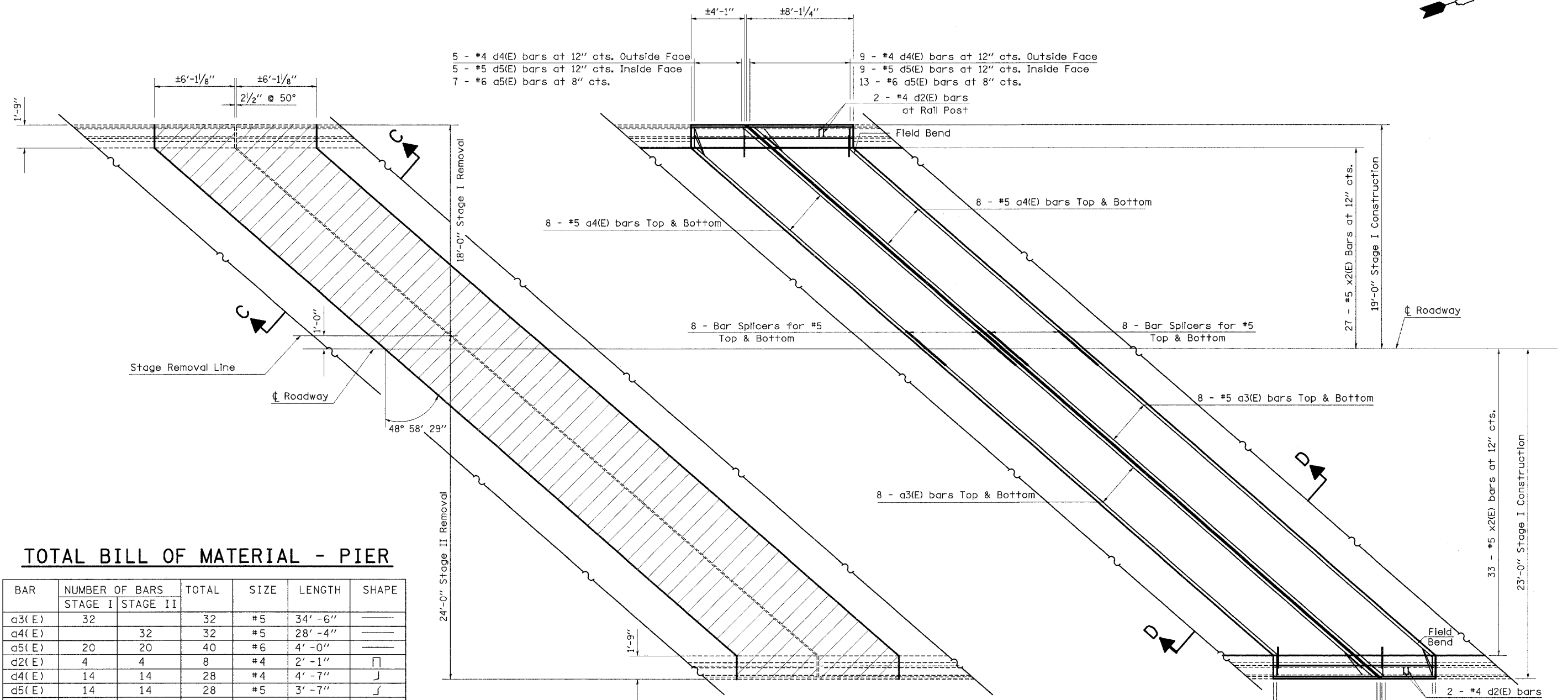

TOTAL BILL OF MATERIAL - PIER

BAR	NUMBER OF BARS		TOTAL	SIZE	LENGTH	SHAPE
	STAGE I	STAGE II				
a3(E)	32		32	#5	34'-6"	—
a4(E)		32	32	#5	28'-4"	—
a5(E)	20	20	40	#6	4'-0"	—
d2(E)	4	4	8	#4	2'-1"	□
d4(E)	14	14	28	#4	4'-7"	J
d5(E)	14	14	28	#5	3'-7"	J
x2(E)	66	54	120	#5	4'-6"	—
CONCRETE REMOVAL				CU. YD.	19.3	
REINFORCEMENT BARS (EPOXY COATED)				POUND	3100	
CONCRETE SUPERSTRUCTURE				CU. YD.	21.9	

REINFORCEMENT BARS DESIGNATED (E) SHALL BE EPOXY COATED

EXISTING PARTIAL PLAN

PROPOSED PARTIAL PLAN

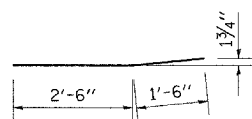

BAR a4(E)

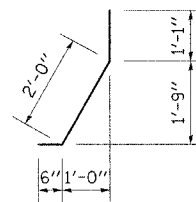

BAR d5(E)

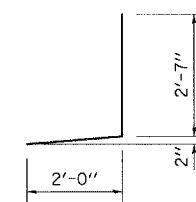

BAR d4(E)

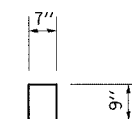

BAR d2(E)

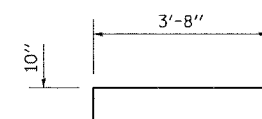

BAR x2(E)

FILE NAME =
c:\projects\174171d\karenbridge.dgn

USER NAME = swartzrk
PLOT SCALE = 20,0000 ' / IN.
PLOT DATE = 3/26/2008

DESIGNED -
DRAWN -
CHECKED -
DATE -

REVISED -
REVISED -
REVISED -
REVISED -

**STATE OF ILLINOIS
DEPARTMENT OF TRANSPORTATION**

**HINGE EXPANSION JOINT REPLACEMENT DETAILS
SN 058-0095 (EB)**

SCALE: N/A SHEET NO. 21 OF 52 SHEETS STA. TO STA.

F.A.I. R.T.E. 72 SECTION (58,74X66,67)RS-1 COUNTY MACON TOTAL SHEETS 88 SHEET NO. 4 CONTRACT NO. 741 ILLINOIS FED. AID PROJECT

Note: Trim existing long. reinf. to accomodate new joint opening (typ.)

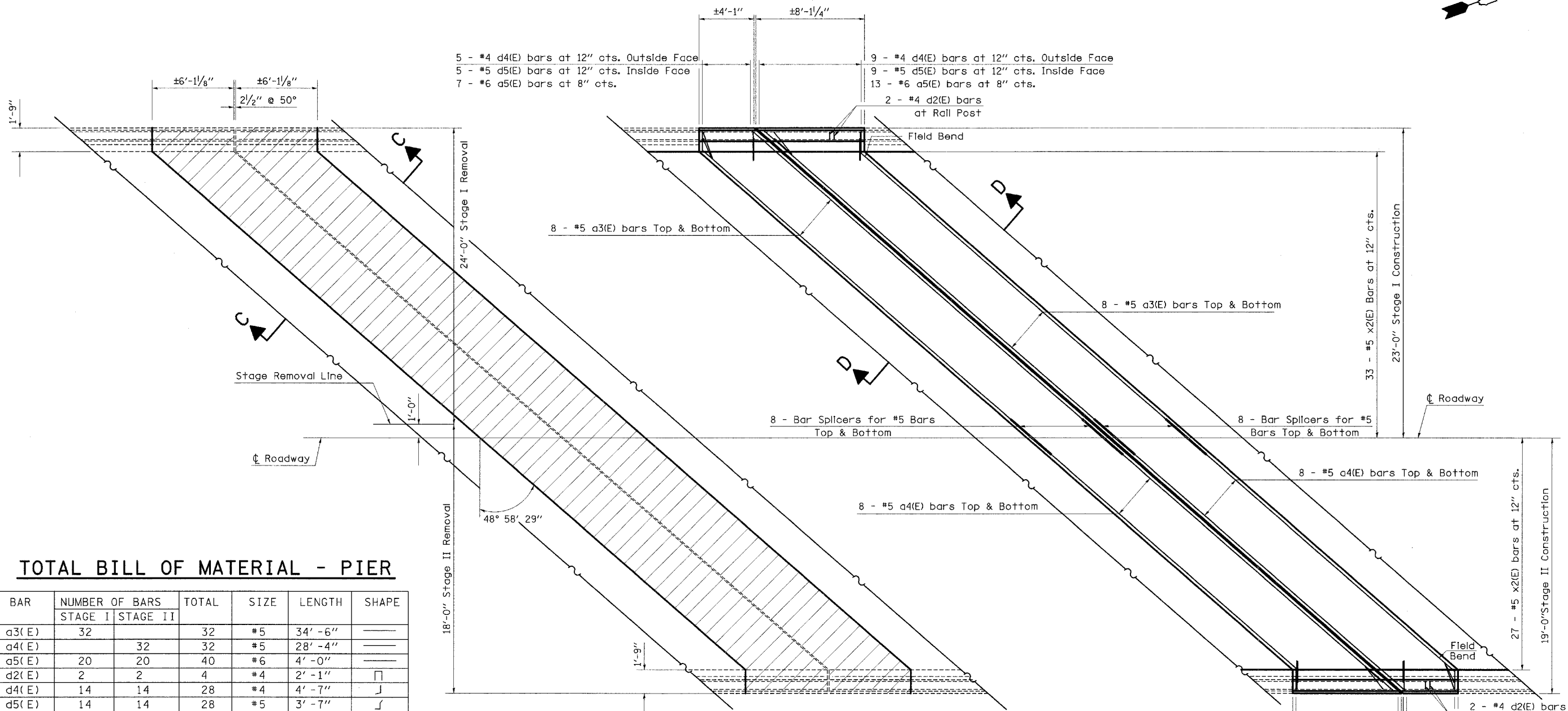
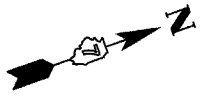

TOTAL BILL OF MATERIAL - PIER

BAR	NUMBER OF BARS		TOTAL	SIZE	LENGTH	SHAPE
	STAGE I	STAGE II				
a3(E)	32		32	#5	34' - 6"	—
a4(E)		32	32	#5	28' - 4"	—
a5(E)	20	20	40	#6	4' - 0"	—
d2(E)	2	2	4	#4	2' - 1"	□
d4(E)	14	14	28	#4	4' - 7"	J
d5(E)	14	14	28	#5	3' - 7"	J
x2(E)	66	54	120	#5	4' - 6"	—

CONCRETE REMOVAL	CU. YD.	20.7
REINFORCEMENT BARS (EPOXY COATED)	POUND	3100
CONCRETE SUPERSTRUCTURE	CU. YD.	23.2

REINFORCEMENT BARS DESIGNATED (E) SHALL BE EPOXY COATED

EXISTING PARTIAL PLAN

PROPOSED PARTIAL PLAN

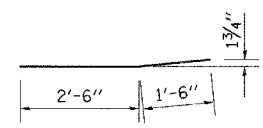

BAR a4(E)

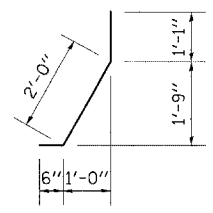

BAR d5(E)

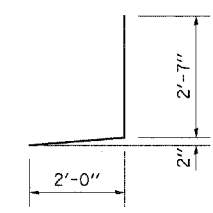

BAR d4(E)

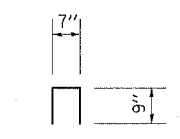

BAR d2(E)

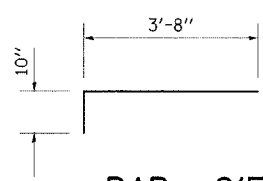

BAR x2(E)

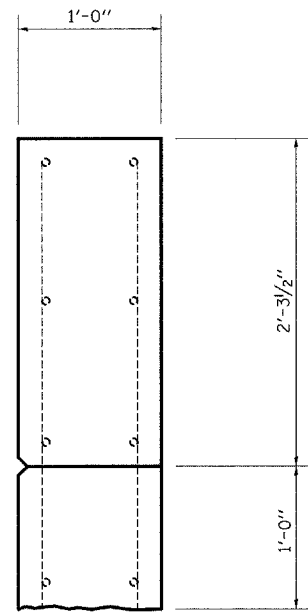

WINGWALL DETAIL

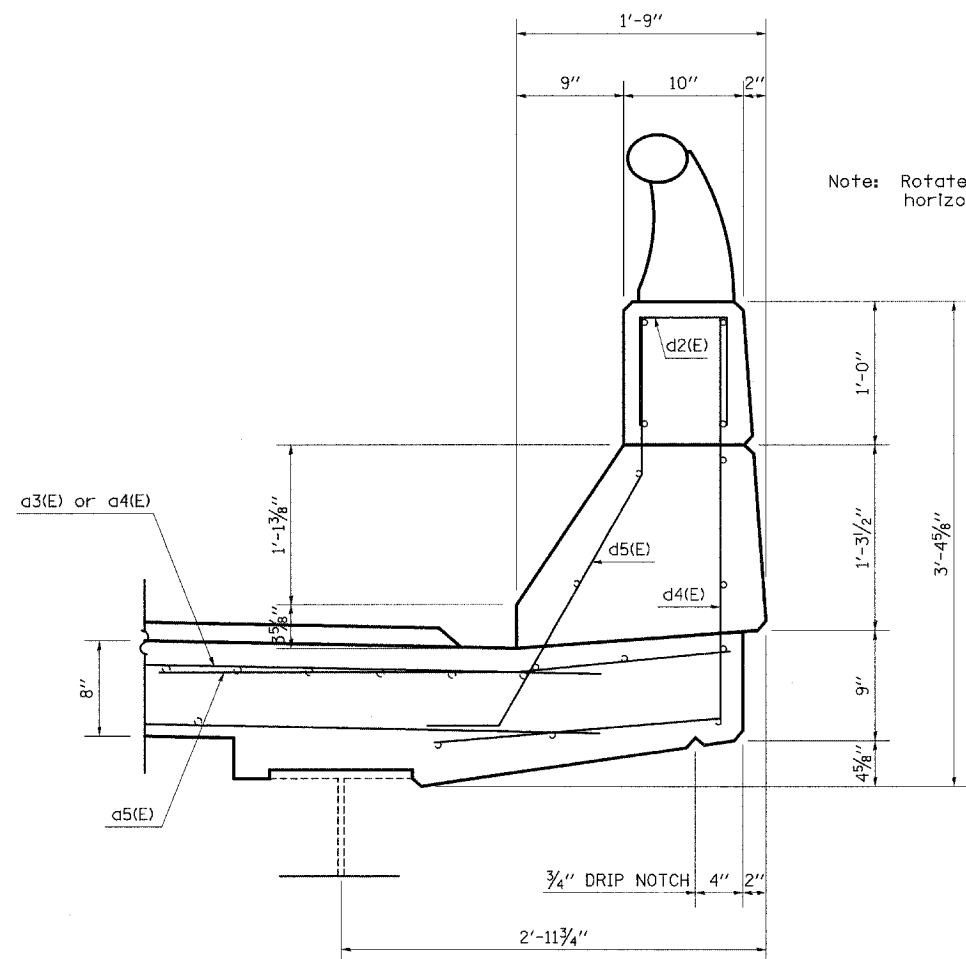

Note: Rotate d4(E) and d5(E) bars in parapet to fit horizontal legs in concrete pour.

SECTION THRU PARAPET

- 058-0096(WB) East Abut. 15"
- 058-0096(WB) West Abut. 14"
- 058-0095(EB) West Abut. 13"
- 058-0095(EB) East Abut. 12"

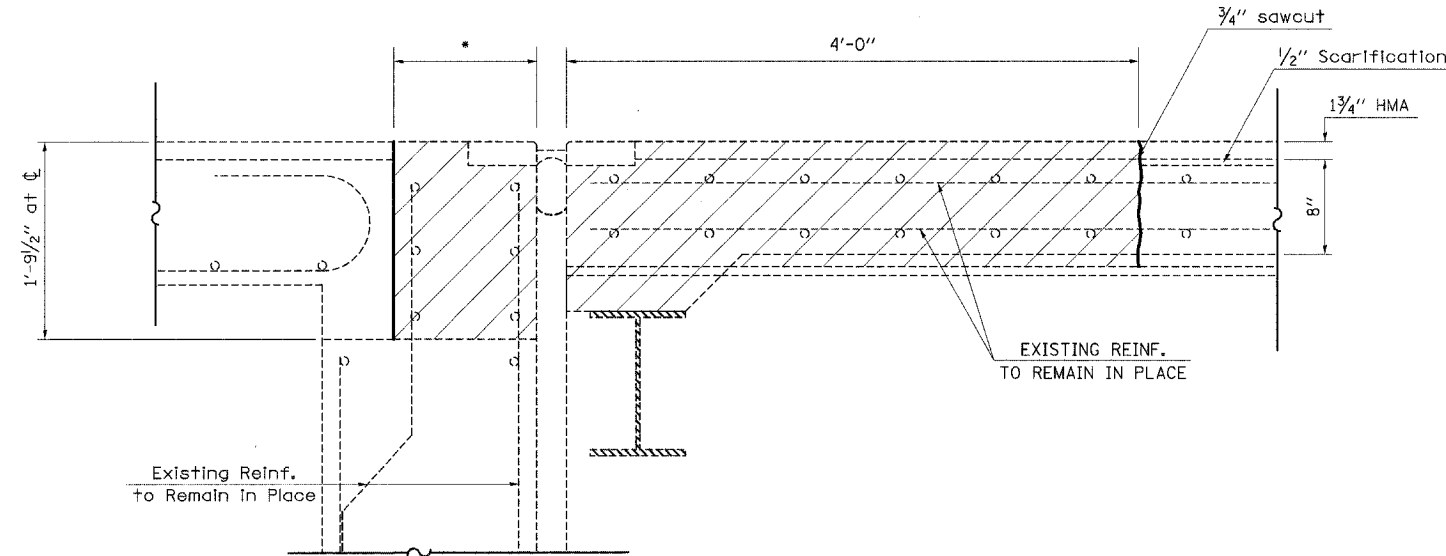

SECTION A-A

(Dimensions at RT L's to end of deck)

- Existing Reinforcement
- Proposed Reinforcement

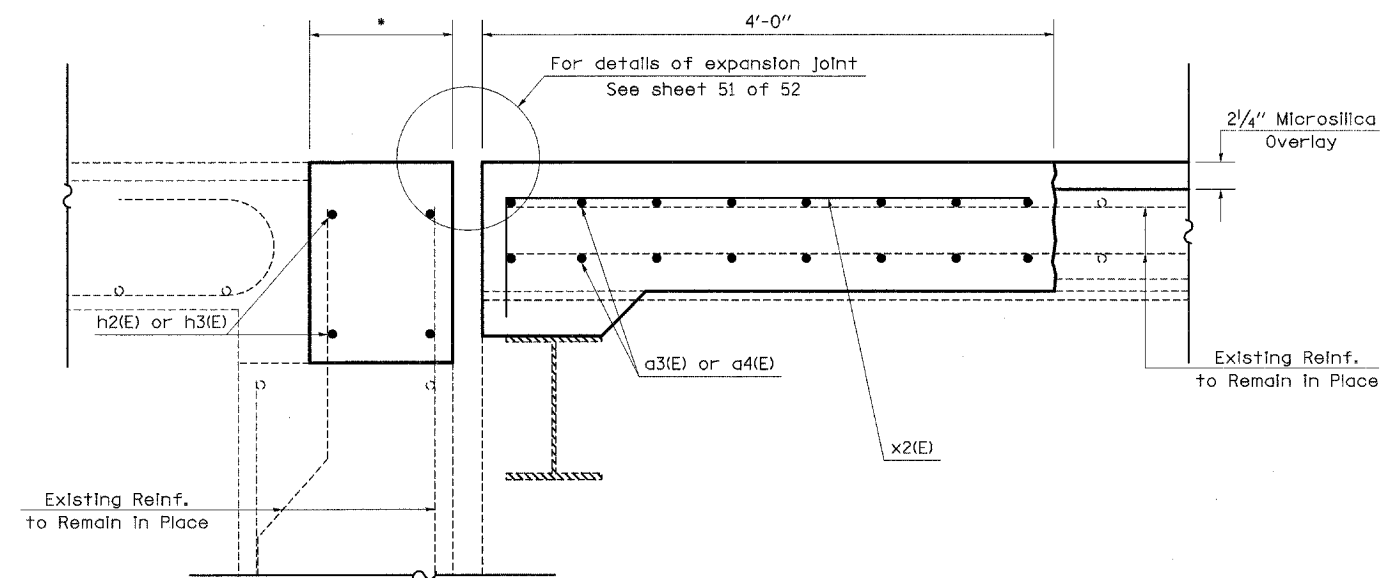

SECTION B-B

(Dimensions at RT L's to end of deck)

FILE NAME = c:\projects\74171d\karenbridge.dgn	USER NAME = swartzrk	DESIGNED -	REVISED -
		DRAWN -	REVISED -
	PLOT SCALE = 20.0000 ' / IN.	CHECKED -	REVISED -
	PLOT DATE = 3/20/2008	DATE -	REVISED -

**STATE OF ILLINOIS
DEPARTMENT OF TRANSPORTATION**

**ABUTMENT EXPANSION JOINT REPLACEMENT DETAILS
SN 058-0095 (EB) & SN 058-0096 (WB)**

SCALE: N/A SHEET NO. 24 OF 52 SHEETS STA. TO STA.

F.A.I. RTE. 72	SECTION (58,74X66,67)RS-1	COUNTY MACON	TOTAL SHEETS 88	SHEET NO. 4
CONTRACT NO. 741			ILLINOIS FED. AID PROJECT	

SHEET NO. 24 OF 52 SHEETS

Note: Rotate d4(E) and d5(E) bars in parapet to fit horizontal legs in concrete pour.

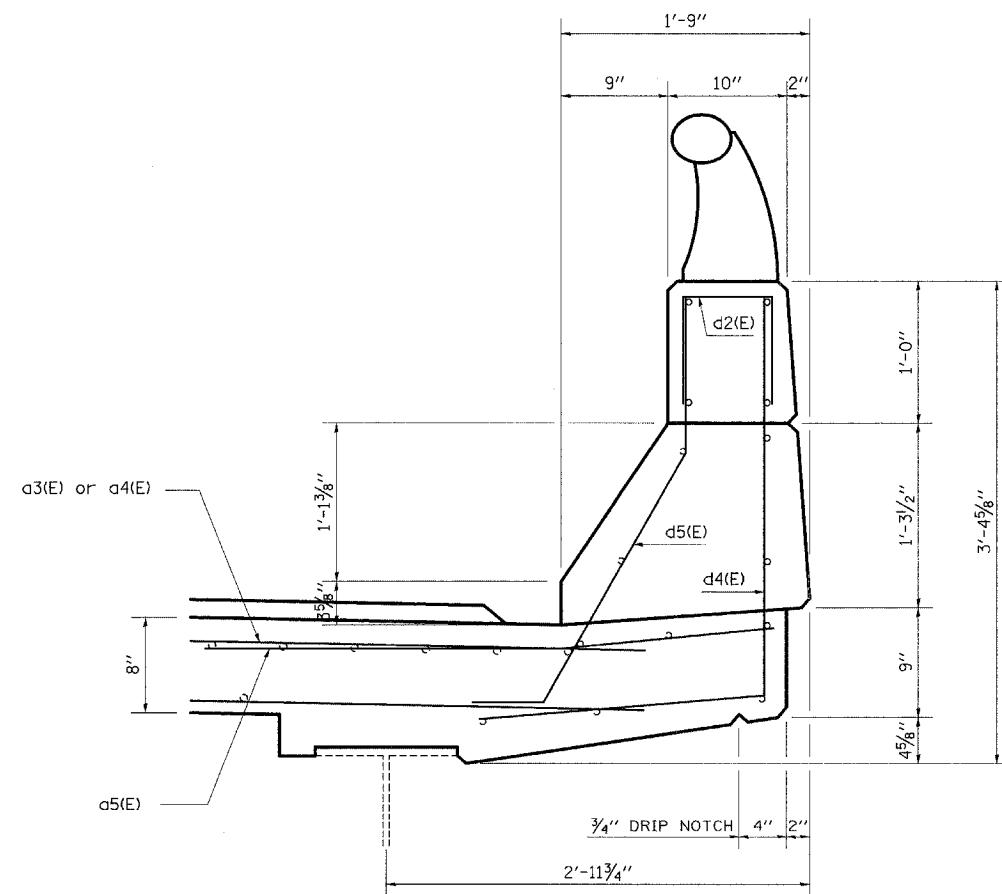

SECTION THRU PARAPET

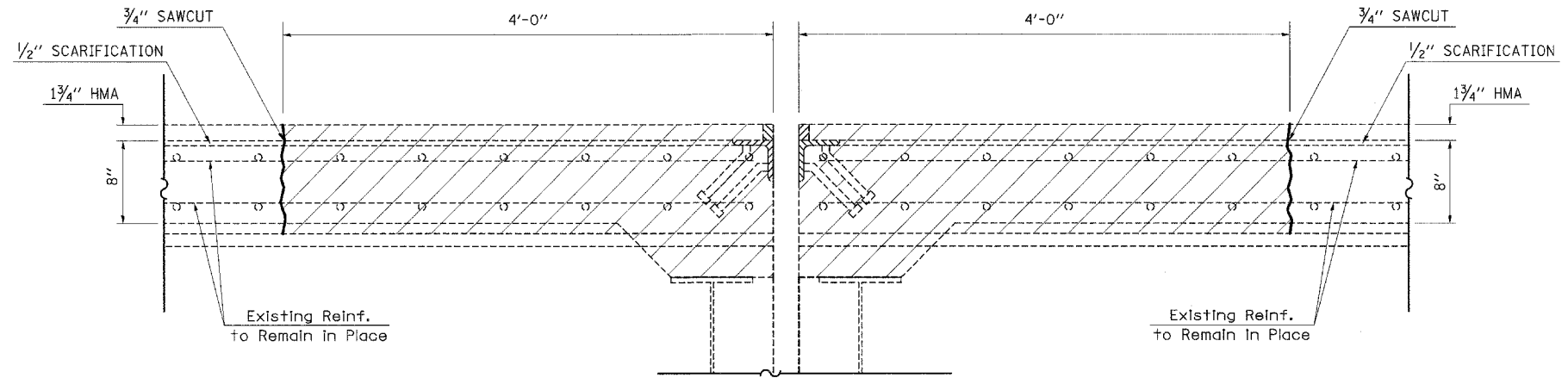

SECTION C-C
(Dimensions at RT L's to end of deck)

○ Existing Reinforcement
● Proposed Reinforcement

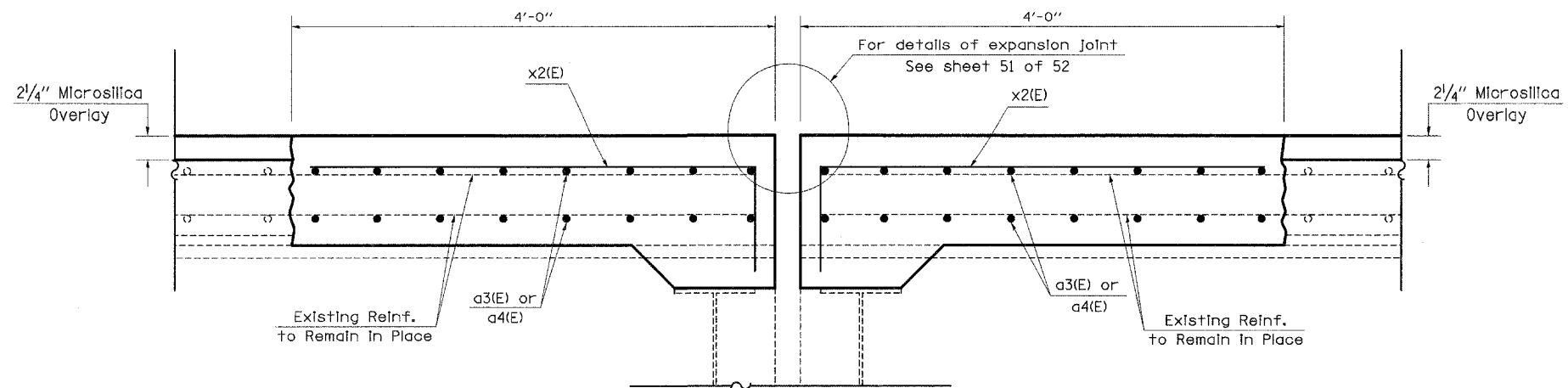

SECTION D-D
(Dimensions at RT L's to end of deck)

FILE NAME = c:\projects\74171d\karenbridge.dgn	USER NAME = swartzw	DESIGNED -	REVISED -
		DRAWN -	REVISED -
	PLOT SCALE = 20,0000 1 / IN.	CHECKED -	REVISED -
	PLOT DATE = 3/20/2008	DATE -	REVISED -

**STATE OF ILLINOIS
DEPARTMENT OF TRANSPORTATION**

**HINGE EXPANION JOINT REPLACEMENT DETAILS
SN 058-0095 (EB) & SN 058-0096 (WB)**

SCALE: N/A SHEET NO. 25 OF 52 SHEETS STA. TO STA.

F.A.I. RTE. 72	SECTION (58,74X66,67)RS-1	COUNTY MACON	TOTAL SHEETS 88	SHEET NO. 52
FED. ROAD DIST. NO. ILLINOIS FED. AID PROJECT			CONTRACT NO. 74171	

SHEET NO.
52 SHEET

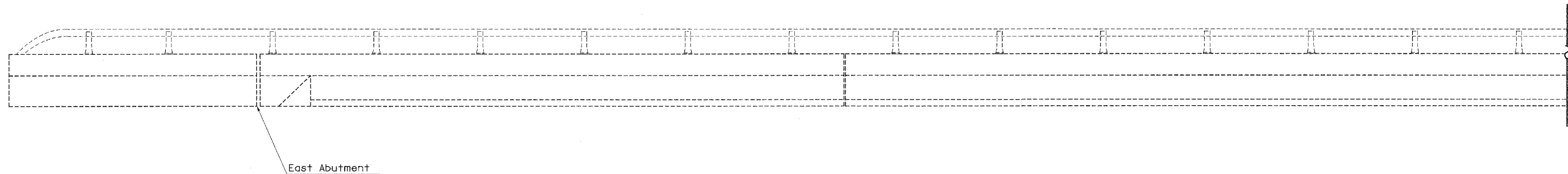

East Abutment

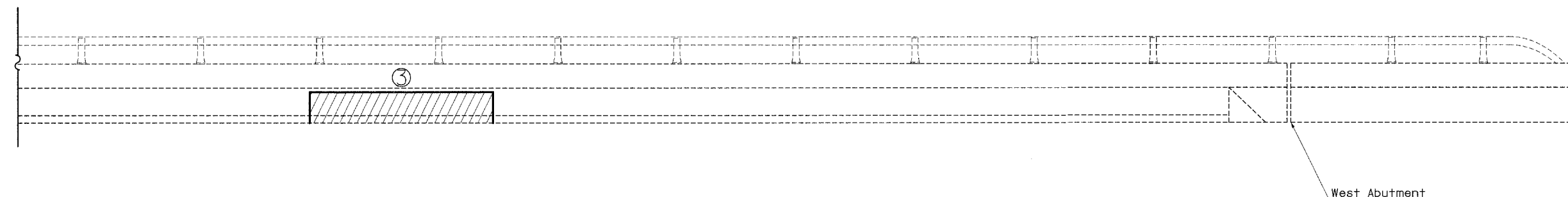
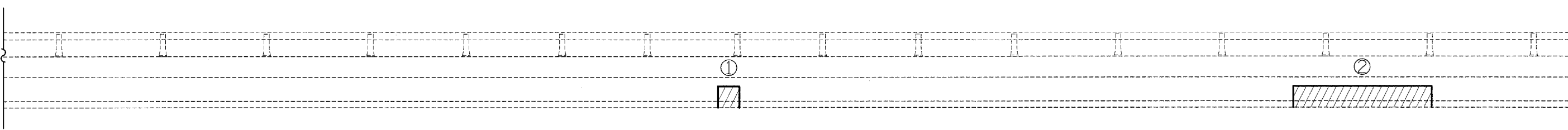

West Abutment

SOUTH PARAPET
Looking South

STRUCTURAL REPAIR

Cost Included In Structural Repair
of Concrete (Depth <5")

PATCH NUMBER	STATION	AREA SQ FT
1	800+10	2.0
2	800+69	13.0
3	801+21	18.8
	Total	33.8

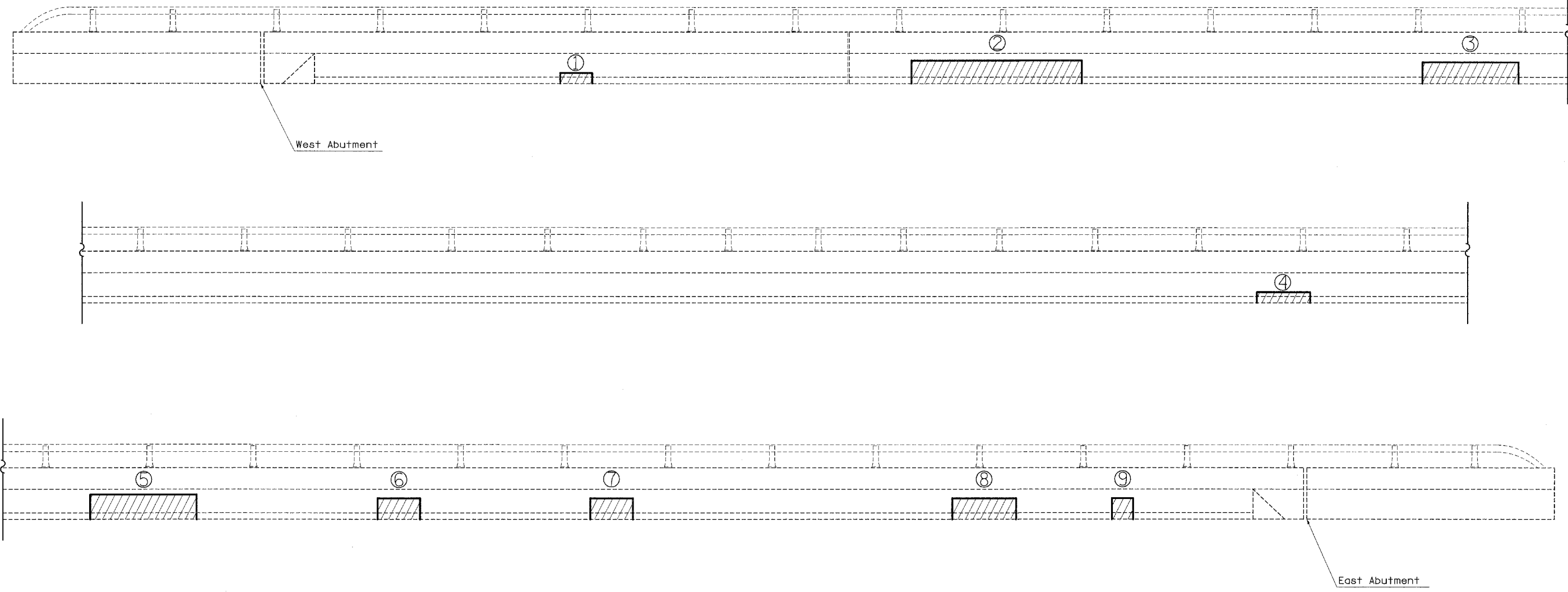

NORTH PARAPET
Looking North

STRUCTURAL REPAIR

Cost Included in Structural Repair of Concrete (Depth <5')

PATCH NUMBER	STATION	AREA SQ. FT.
1	796+69	1.5
2	797+08	17.3
3	797+53	9.0
4	798+75	2.5
5	799+05	11.7
6	799+29	4.0
7	799+49	4.0
8	799+84	6.0
9	799+97	2.0
	Total	58.0

FILE NAME = c:\projects\74171d\karenbridge.dgn	USER NAME = swartzw	DESIGNED -	REVISED -
		DRAWN -	REVISED -
	PLOT SCALE = 20.0000' / IN.	CHECKED -	REVISED -
	PLOT DATE = 3/20/2008	DATE -	REVISED -

STATE OF ILLINOIS
DEPARTMENT OF TRANSPORTATION

STRUCTURAL REPAIR - PARAPET
SN 058-0096 (WB)

SCALE: N/A SHEET NO. 28 OF 52 SHEETS STA. TO STA.

F.A.I. RTE. 72	SECTION (58,74X66.67)RS-1	COUNTY MACON	TOTAL SHEETS 88	SHEETS NO. 53
FED. ROAD DIST. NO. ILLINOIS FED. AID PROJECT			CONTRACT NO. 74171	

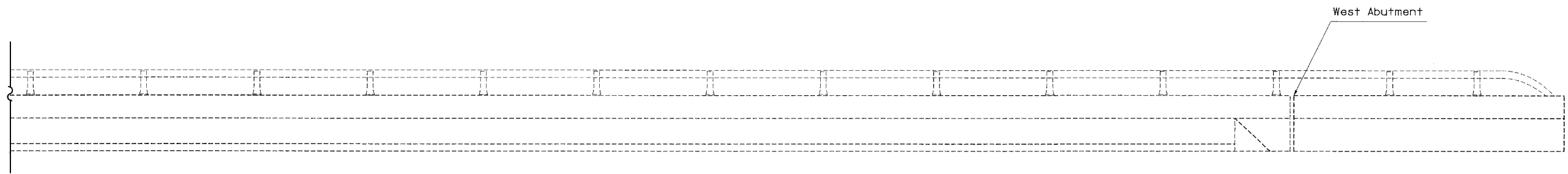
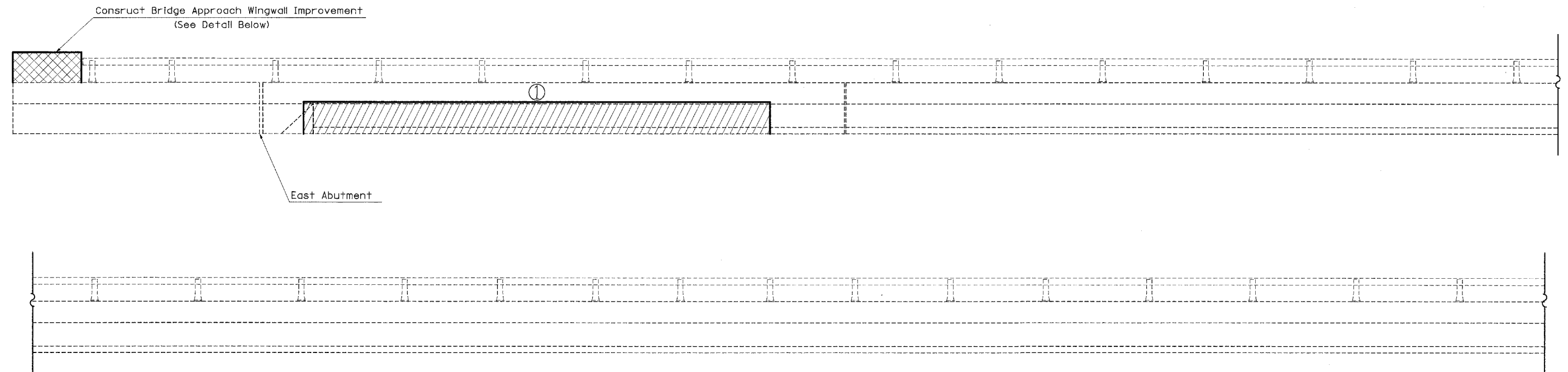

SOUTH PARAPET
Looking South

BILL OF MATERIAL

BAR	NUMBER OF BARS	SIZE	LENGTH	SHAPE
d8(E)	5	#5	2'-1"	
s(E)	9	#5	3'-1 1/2"	
h7(E)	4	#5	7'-8"	
REINFORCEMENT BARS (EPOXY COATED)			POUND	120
CONCRETE SUPERSTRUCTURE			CU YD	0.3

STRUCTURAL REPAIR

Cost Included In Structural Repair of Concrete (Depth <5'>)

PATCH NUMBER	STATION	AREA SQ FT
1	797+11	66.0
	Total	66.0

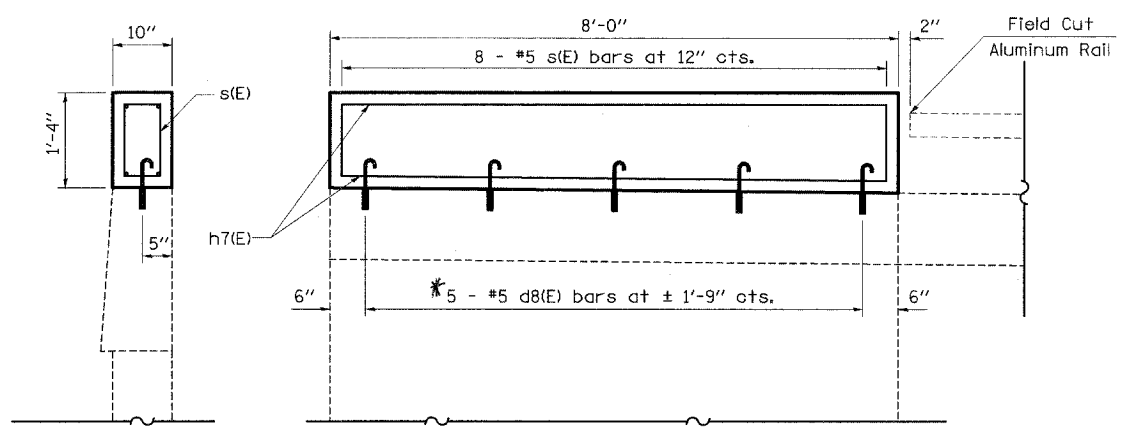

* Epoxy Grouted Bars In accordance with Art. 584 of the Standard Specs.

BRIDGE APPROACH WINGWALL IMPROVEMENT DETAIL
Southeast Wingwall Only

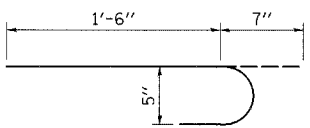

BAR d8(E)

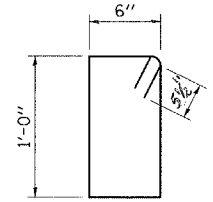

BAR s(E)



PIER #1 - WEST FACE

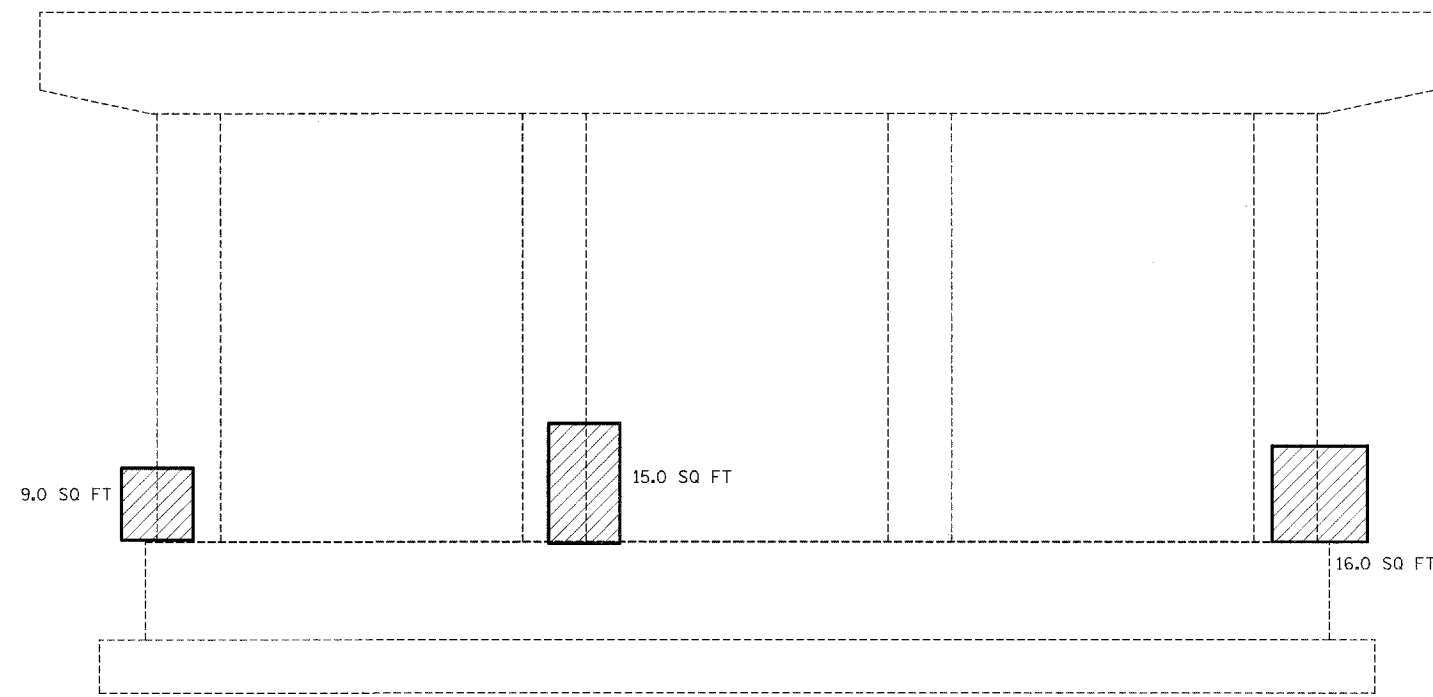

PIER #2 - WEST FACE

NOTE: QUANTITIES ARE ESTIMATED. ACTUAL QUANTITIES TO BE DETERMINED BY THE RESIDENT ENGINEER.



Structural Repair of Concrete (Depth < 5")

FILE NAME = c:\projects\74171d\korenbr\edge.dgn	USER NAME = swartzrw	DESIGNED -	REVISED -
		DRAWN -	REVISED -
	PLOT SCALE = 20.0000 "/ IN.	CHECKED -	REVISED -
	PLOT DATE = 3/20/2008	DATE -	REVISED -

**STATE OF ILLINOIS
DEPARTMENT OF TRANSPORTATION**

**STRUCTURAL REPAIR - SUBSTRUCTURE
SN 058-0095 EB**

SCALE: N/A SHEET NO. 30 OF 52 SHEETS STA. TO STA.

F.A.I. RTE.	SECTION	COUNTY	TOTAL SHEETS	SHEET NO.
72	(58,74X66,67)RS-1	MACON	88	5
FED. ROAD DIST. NO. ILLINOIS FED. AID PROJECT			CONTRACT NO. 741	

SHEET NO. 52 SHEETS

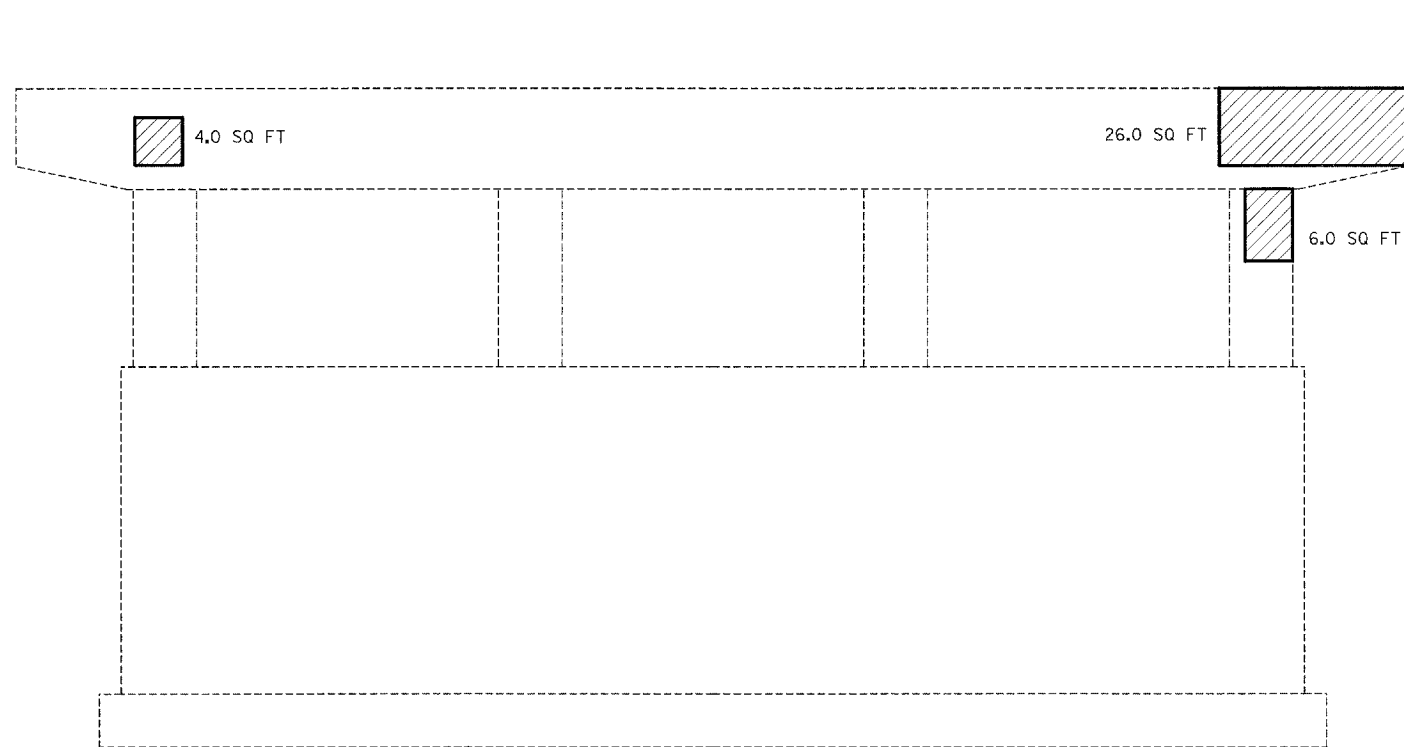

PIER #1 - WEST FACE

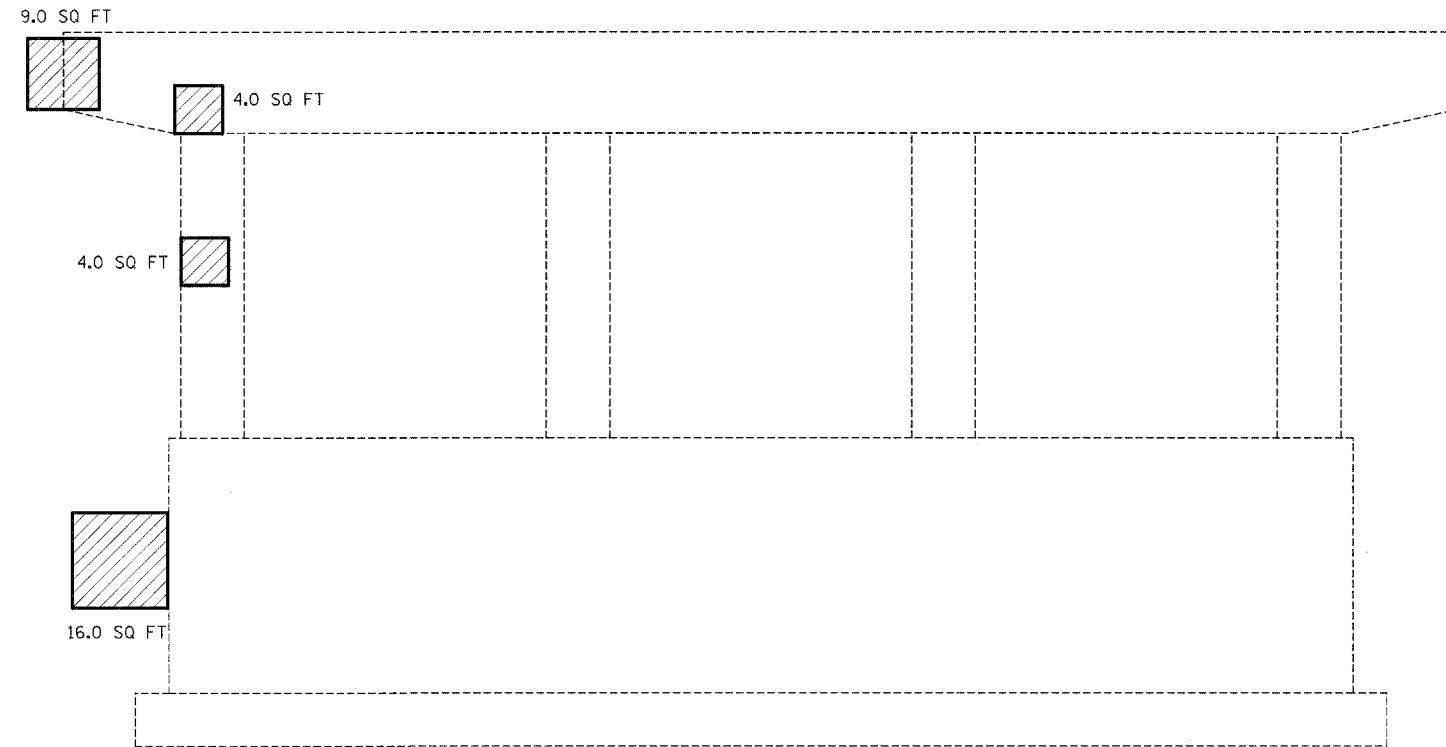

PIER #3 - WEST FACE

NOTE: QUANTITIES ARE ESTIMATED. ACTUAL QUANTITIES TO BE DETERMINED BY THE RESIDENT ENGINEER.

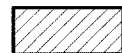

Structural Repair of Concrete (Depth < 5")

FILE NAME = c:\projects\74171d\karenbridge.dgn	USER NAME = swartzk	DESIGNED -	REVISED -
		DRAWN -	REVISED -
	PLOT SCALE = 20.0000 1/ IN.	CHECKED -	REVISED -
	PLOT DATE = 3/20/2009	DATE -	REVISED -

**STATE OF ILLINOIS
DEPARTMENT OF TRANSPORTATION**

**STRUCTURAL REPAIR - SUBSTRUCTURE
SN 058-0096**

SCALE: N/A SHEET NO. 31 OF 52 SHEETS STA. TO STA.

F.A.I. RTE.	SECTION	COUNTY	TOTAL SHEETS	SHEET NO.
72	(58,74X66,67)RS-1	MACON	88	31
FED. ROAD DIST. NO.			ILLINOIS FED. AID PROJECT	CONTRACT NO. 741

SHEET NO. 31 OF 52 SHEETS

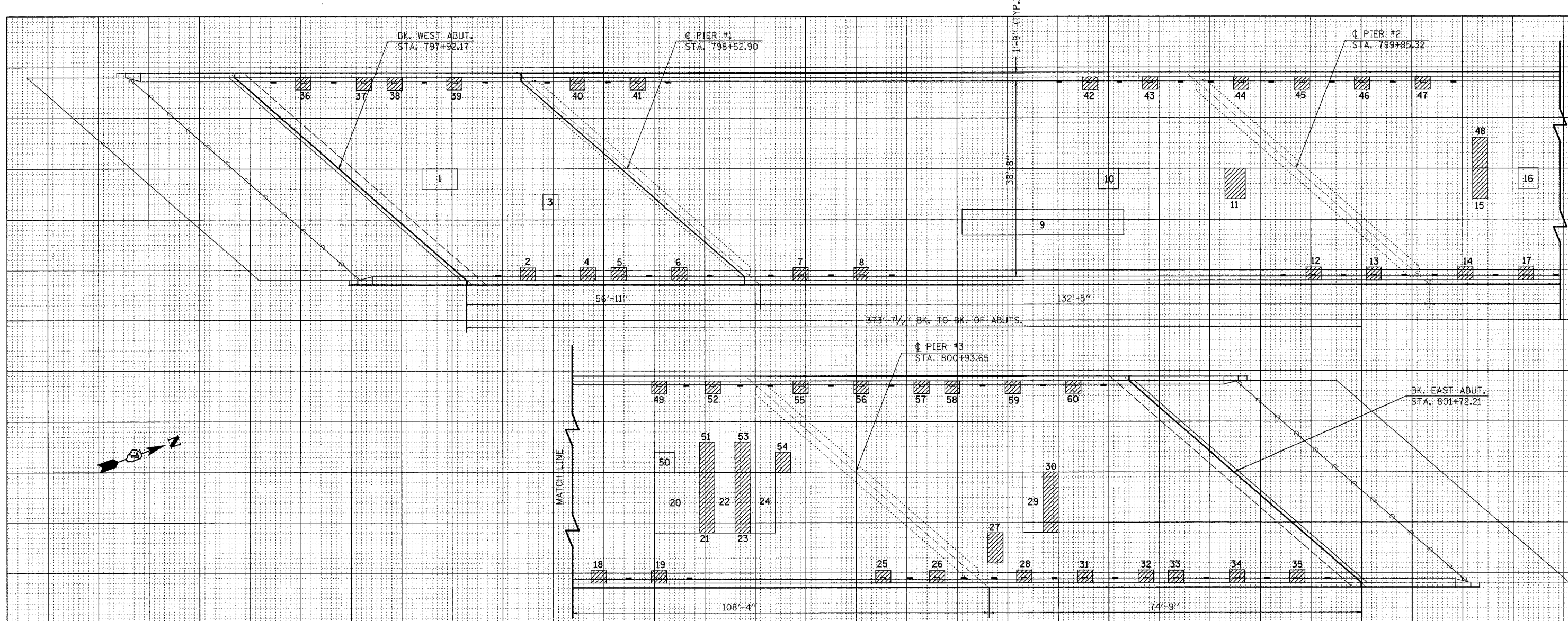

PATCH NO.	SIZE	DECK SLAB REPAIR (PART DEPTH)		
		SQ FT	SQ FT	SQ FT
1	7.0 x 4.0	28.0		
2	1.8 x 1.2		2.2	
3	3.0 x 3.0	9.0		
4	1.8 x 1.2		2.2	
5	1.8 x 1.2		2.2	
6	1.8 x 1.2		2.2	
7	1.8 x 1.2		2.2	
8	1.8 x 1.2		2.2	
9	32.0 x 5.0	160.0		
10	4.0 x 4.0	16.0		
11	4.0 x 6.0			24.0
12	1.8 x 1.2		2.2	
13	1.8 x 1.2		2.2	
14	1.8 x 1.2		2.2	
15	3.0 x 6.0			18.0
16	4.0 x 4.0	16.0		
17	1.8 x 1.2		2.2	
18	1.8 x 1.2		2.2	

PATCH NO.	SIZE	DECK SLAB REPAIR (PART DEPTH)		
		SQ FT	SQ FT	SQ FT
19	1.8 x 1.2		2.2	
20	9.0 x 12.0	108.0		
21	3.0 x 12.0			36.0
22	4.0 x 12.0	48.0		
23	3.0 x 12.0			36.0
24	5.0 x 12.0	60.0		
25	1.8 x 1.2		2.2	
26	1.8 x 1.2		2.2	
27	3.0 x 6.0			18.0
28	1.8 x 1.2		2.2	
29	4.0 x 12.0	48.0		
30	3.0 x 12.0			36.0
31	1.8 x 1.2		2.2	
32	1.8 x 1.2		2.2	
33	1.8 x 1.2		2.2	
34	1.8 x 1.2		2.2	
35	1.8 x 1.2		2.2	
36	1.8 x 1.2		2.2	

PATCH NO.	SIZE	DECK SLAB REPAIR (PART DEPTH)		
		SQ FT	SQ FT	SQ FT
37	1.8 x 1.2		2.2	
38	1.8 x 1.2		2.2	
39	1.8 x 1.2		2.2	
40	1.8 x 1.2		2.2	
41	1.8 x 1.2		2.2	
42	1.8 x 1.2		2.2	
43	1.8 x 1.2		2.2	
44	1.8 x 1.2		2.2	
45	1.8 x 1.2		2.2	
46	1.8 x 1.2		2.2	
47	1.8 x 1.2		2.2	
48	3.0 x 6.0			18.0
49	1.8 x 1.2		2.2	
50	4.0 x 4.0	16.0		
51	3.0 x 6.0			18.0
52	1.8 x 1.2		2.2	
53	3.0 x 6.0			18.0
54	3.0 x 4.0			12.0

PATCH NO.	SIZE	DECK SLAB REPAIR (PART DEPTH)			
		SQ FT	SQ FT	SQ FT	SQ FT
55	1.8 x 1.2		2.2		
56	1.8 x 1.2		2.2		
57	1.8 x 1.2		2.2		
58	1.8 x 1.2		2.2		
59	1.8 x 1.2		2.2		
60	1.8 x 1.2		2.2		
TOTAL		509	88	234	0

PATCH NO.	SIZE	DECK SLAB REPAIR (PART DEPTH)		
		SQ FT	SQ FT	SQ FT
PARTIAL DEPTH (FOR INFORMATION ONLY)				
509 / 9 = 56.6 USE		57	50	YD
FULL DEPTH, TYPE 1				
88 / 9 = 9.8 USE		10	50	YD
FULL DEPTH, TYPE 2				
234 / 9 = 26.0 USE		26	50	YD

THE LOCATIONS AND SIZES SHOWN GRAPHICALLY ABOVE ARE APPROXIMATE. SEE THE TABLE FOR ACTUAL SIZES.

PATCHING LEGEND

- PARTIAL DEPTH (FOR INFORMATION ONLY)
- FULL DEPTH
- FLOOR DRAIN TO BE REPLACED
- FLOOR DRAIN TO BE PLUGGED

DATE OF SURVEY: 10/30/00
 SURVEY BY: M. ALLEN, K. THOMAS
 METHOD OF SURVEY: VISUAL

BRIDGE DECK PATCHING
 MACON COUNTY

SHEET NO. 32
 52 SHEETS

095

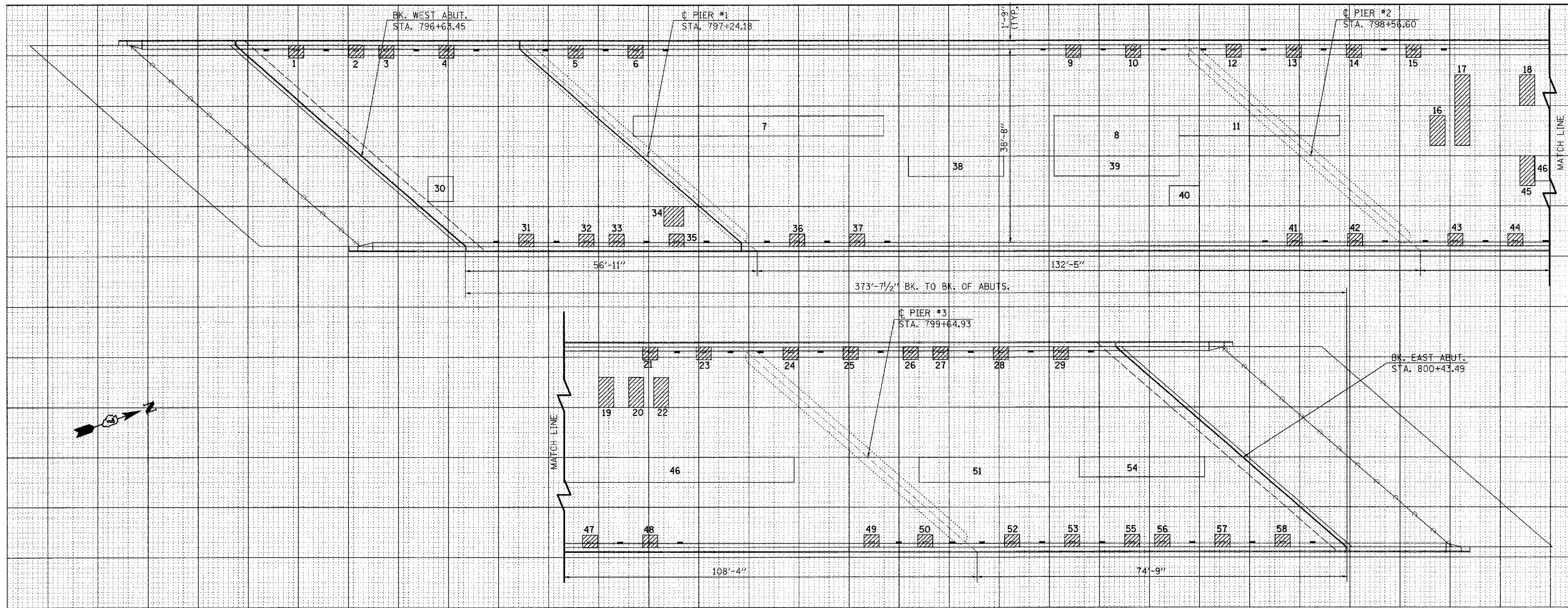

PATCH NO.	SIZE	DECK SLAB REPAIR (PART DEPTH)		
		SQ FT	SQ FT	SQ FT
1	1.8 x 1.2		2.2	
2	1.8 x 1.2		2.2	
3	1.8 x 1.2		2.2	
4	1.8 x 1.2		2.2	
5	1.8 x 1.2		2.2	
6	1.8 x 1.2		2.2	
7	50.0 x 4.0	200.0		
8	25.0 x 8.0	200.0		
9	1.8 x 1.2		2.2	
10	1.8 x 1.2		2.2	
11	32.0 x 4.0	128.0		
12	1.8 x 1.2		2.2	
13	1.8 x 1.2		2.2	
14	1.8 x 1.2		2.2	
15	1.8 x 1.2		2.2	
16	3.0 x 6.0			18.0
17	3.0 x 14.0			42.0
18	3.0 x 6.0			18.0

PATCH NO.	SIZE	DECK SLAB REPAIR (PART DEPTH)		
		SQ FT	SQ FT	SQ FT
19	3.0 x 6.0			18.0
20	3.0 x 6.0			18.0
21	1.8 x 1.2		2.2	
22	3.0 x 6.0			18.0
23	1.8 x 1.2		2.2	
24	1.8 x 1.2		2.2	
25	1.8 x 1.2		2.2	
26	1.8 x 1.2		2.2	
27	1.8 x 1.2		2.2	
28	1.8 x 1.2		2.2	
29	1.8 x 1.2		2.2	
30	5.0 x 5.0	25.0		
31	1.8 x 1.2		2.2	
32	1.8 x 1.2		2.2	
33	1.8 x 1.2		2.2	
34	4.0 x 4.0			16.0
35	1.8 x 1.2		2.2	
36	1.8 x 1.2		2.2	

PATCH NO.	SIZE	DECK SLAB REPAIR (PART DEPTH)		
		SQ FT	SQ FT	SQ FT
37	1.8 x 1.2		2.2	
38	19.0 x 4.0	76.0		
39	25.0 x 4.0			100.0
40	6.0 x 4.0			24.0
41	1.8 x 1.2		2.2	
42	1.8 x 1.2		2.2	
43	1.8 x 1.2		2.2	
44	1.8 x 1.2		2.2	
45	3.0 x 6.0			18.0
46	52.0 x 5.0	260.0		
47	1.8 x 1.2		2.2	
48	1.8 x 1.2		2.2	
49	1.8 x 1.2		2.2	
50	1.8 x 1.2		2.2	
51	26.0 x 5.0	130.0		
52	1.8 x 1.2		2.2	
53	1.8 x 1.2		2.2	
54	25.0 x 4.0	100.0		

PATCH NO.	SIZE	DECK SLAB REPAIR (PART DEPTH)		
		SQ FT	SQ FT	SQ FT
55	1.8 x 1.2		2.2	
56	1.8 x 1.2		2.2	
57	1.8 x 1.2		2.2	
58	1.8 x 1.2		2.2	
TOTAL		1119	88	290

PATCH NO.	SIZE	DECK SLAB REPAIR (PART DEPTH)		
		SQ FT	SQ FT	SQ FT
PARTIAL DEPTH				
1119 / 9 = 124.3				
USE 124 SQ YD				
FULL DEPTH, TYPE 1				
88 / 9 = 9.8				
USE 10 SQ YD				
FULL DEPTH, TYPE 2				
290 / 9 = 32.2				
USE 32 SQ YD				

THE LOCATIONS AND SIZES SHOWN GRAPHICALLY ABOVE ARE APPROXIMATE. SEE TABLE FOR ACTUAL SIZES.

PATCHING LEGEND

- PARTIAL DEPTH (FOR INFORMATION ONLY)
- FULL DEPTH
- FLOOR DRAIN TO BE REPLACED
- FLOOR DRAIN TO BE PLUGGED

DATE OF SURVEY: 10/30/00
 SURVEY BY: M. ALLEN, K. THOMAS
 METHOD OF SURVEY: VISUAL

BRIDGE DECK PATCHING
 MACON COUNTY

SHEET NO. 33
 52 SHEETS

096

FILE NAME = c:\projects\bridges\brmacon\dgn
 USER NAME = swart-zrx
 PLOT SCALE = 50.0000" / IN.
 PLOT DATE = 3/28/2008

DESIGNED -
 DRAWN -
 CHECKED -
 DATE -

REVISED -
 REVISED -
 REVISED -
 REVISED -

STATE OF ILLINOIS
 DEPARTMENT OF TRANSPORTATION

DECK SLAB REPAIR
 S.N. 058-0096 (W.B.)
 SCALE: 50 SHEET NO. 30 OF 44 SHEETS STA. TO STA.

F.A.I. RTE. 72 SECTION (58,74)(66,67)RS-1 COUNTY MACON TOTAL SHEETS 78 CONTRACT NO. 74
 FED. ROAD DIST. NO. [ILLINOIS] FED. AID PROJECT

STATE OF ILLINOIS
DEPARTMENT OF TRANSPORTATION

ROUTE NO.	SECTION	COUNTY	TOTAL SHEETS	SHEET NO.	SHEET NO. 1 2 SHEETS
FAI 72		MACON	88	59	
FED. ROAD DIST. NO. 7	ILLINOIS		FED. AID PROJECT		

Contract Number: 74171

NOTES

All structural steel shall conform to AASHTO Classification M-270 Gr. 36, unless otherwise noted.

Plan dimensions and details relative to existing plans are subject to routine variations. The Contractor shall field verify existing dimensions and details affecting new construction and make necessary approved adjustments prior to construction or ordering of materials. Such variations shall not be cause for additional compensation for a change in scope of the work, however, the Contractor will be paid for the quantity actually furnished based upon the unit price bid for the work.

If the analysis submitted to the Contractor for the jacking/temporary support system to be used shows temporary stiffeners are required to prevent web crippling or buckling, the stiffeners shall be steel and bolted to the web. If stiffeners are not required, hardwood timbers shall be installed tightly between the top and bottom flange to prevent flange rotation.

The existing structural steel coating contains lead. The Contractor shall take appropriate precautions to deal with the presence of lead on this project.

Existing structural steel that will be in contact with new structural steel shall be cleaned and painted prior to erection as required by the Special Provision "Cleaning and Painting Contact Surface Areas of Existing Steel Structures".

All structural steel shall be shop painted with the inorganic zinc rich primer per AASHTO M300, Type 1. Cost included with Furnishing and Erecting Structural Steel.

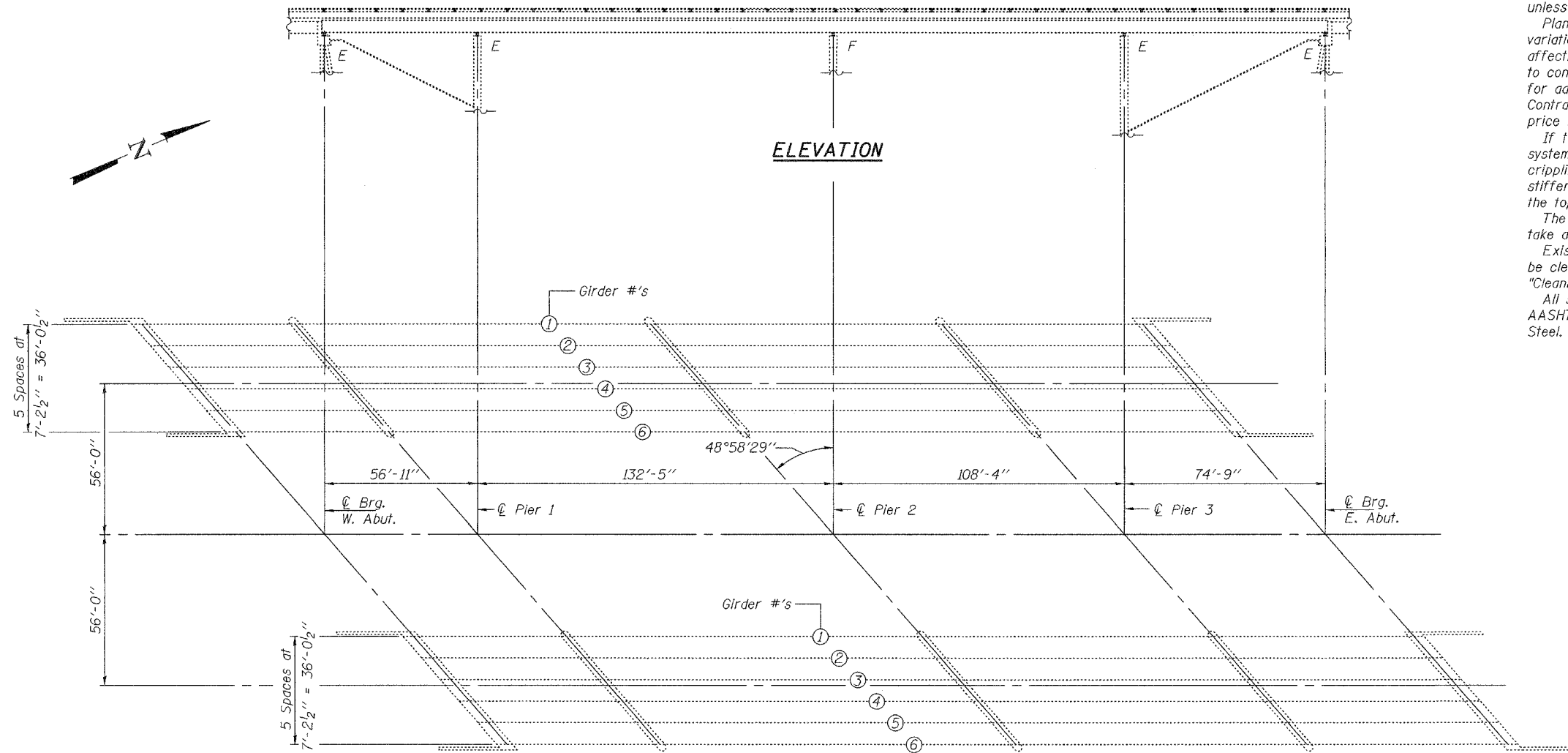

ELEVATION

PLAN

Remove and Replace Bearings at Abutments

BILL OF MATERIAL

ITEM	UNIT	TOTAL
Furnishing & Erecting Structural Steel	Pound	3420
Anchor Bolts, 1"φ	Each	48
Elastomeric Bearing Assembly, Type II	Each	24
Jack and Remove Existing Bearings	Each	24

DESIGNED	<i>[Signature]</i>
CHECKED	<i>[Signature]</i>
DRAWN	Steffen
CHECKED	AJB 558

APRIL 18, 2008
EXAMINED *[Signature]*
ENGINEER OF STRUCTURAL SERVICES
PASSED *[Signature]*
ENGINEER OF BRIDGES AND STRUCTURES



EXPIRES 11-30-2008

**BEARING REPLACEMENT
PLAN & ELEVATION
FAI RT. 72
MACON COUNTY
SN 058-0095 & 0096**

STATE OF ILLINOIS
DEPARTMENT OF TRANSPORTATION

ROUTE NO.	SECTION	COUNTY	TOTAL SHEETS	SHEET NO.
FAI 72		MACON	88	60
FED. ROAD DIST. NO. 7	ILLINOIS	FED. AID PROJECT		

SHEET NO. 2
2 SHEETS

Contract Number: 74171

Notes:
Diaphragm removal and installation may be required to facilitate drilling holes. Cost included with Furnishing and Erecting Structural Steel.
New steel extensions, shim plates and connection bolts are included with Furnishing and Erecting Structural Steel.
Prior to ordering any material, the Contractor shall verify in the field all bearing height and shim thickness dimensions. Min. Jack capacity = 50 Tons.
Anchor bolts shall be ASTM F1554 all-thread (or an Engineer-approved alternate material) of the grade(s) and diameter(s) specified. ASTM A307 Grade C anchor bolts may be used in lieu of ASTM F1554 Grade 36 (Fy=36ksi). The corresponding specified grade of AASHTO M314 anchor bolts may be used in lieu of ASTM F1554.
Anchor bolts for Type II bearings shall be placed in holes drilled through the bottom bearing plate after members are in place. Side retainers shall be placed after bolts are installed.
Side retainers shall be included in the cost of Elastomeric Bearing Assembly, Type II.
The 1/8" TFE sheet shall be bonded directly to the top steel plate with a two-component, medium viscosity epoxy resin, conforming to the requirements of the Federal Specification MMM-A-134, Type I. The bond agent shall be applied on the full area of the contact surfaces.
Bonding of 1/8" TFE sheet during vulcanizing process will be permitted provided the process and method of adjusting assembly height is approved by the Engineer.
Drilled and set anchor bolts shall be installed according to Article 521.06 of the Standard Specifications.

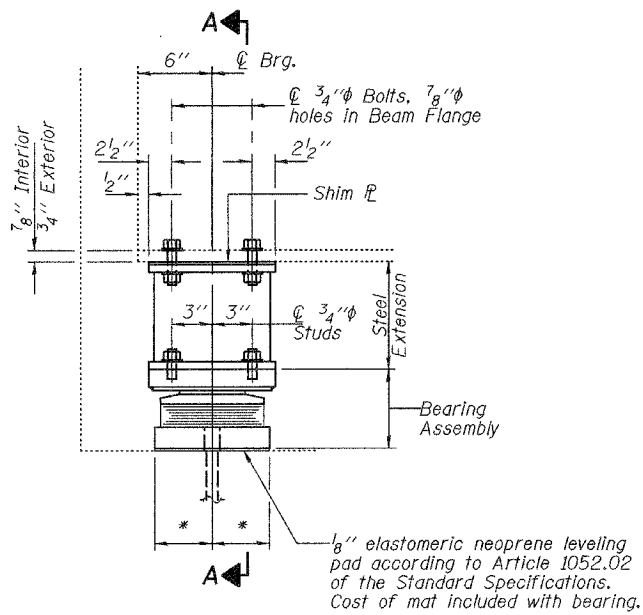

ELEVATION AT ABUTMENTS

TYPE II TFE ELASTOMERIC EXP. BRG.

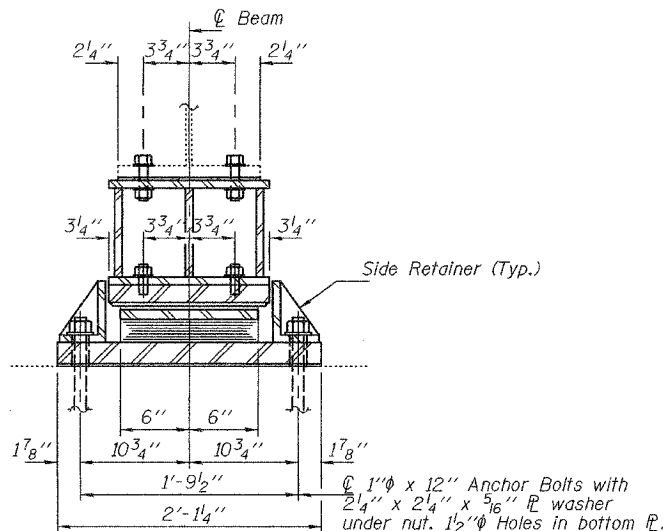

SECTION A-A

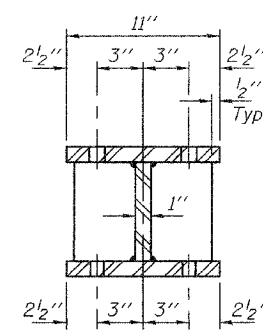

SECTION B-B

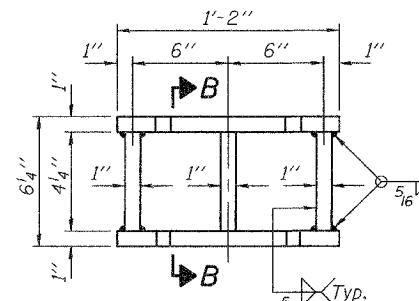

STEEL EXTENSION DETAIL

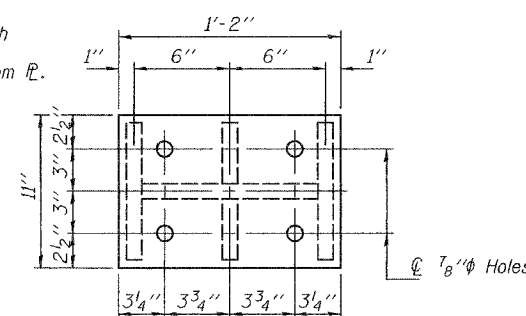

PLAN TOP AND BOTTOM PLATE

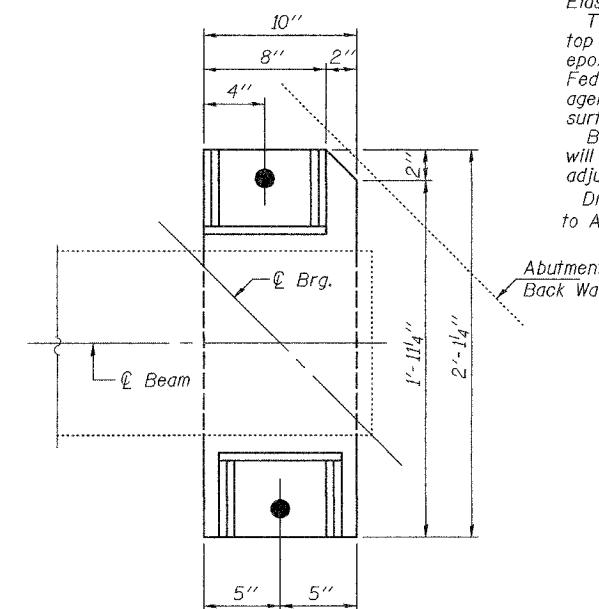

PLAN VIEW OF
BOTTOM BEARING PLATE

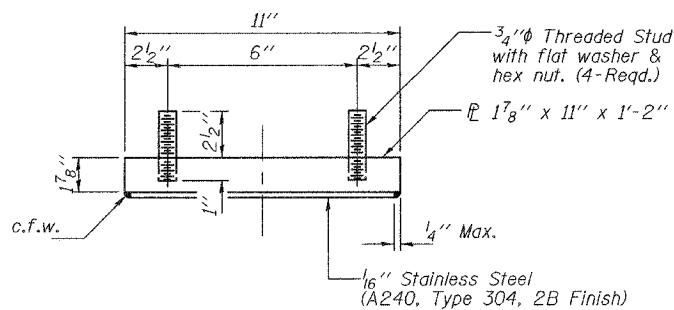

TOP BEARING ASSEMBLY

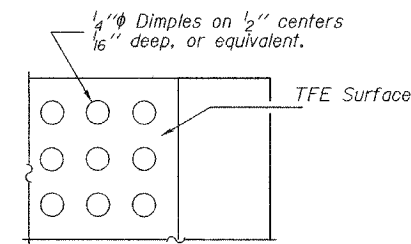

PLAN-TFE SURFACE

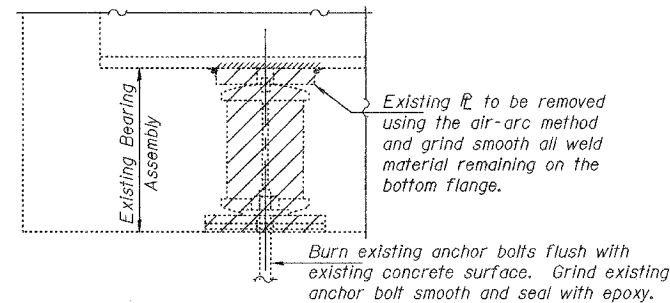

EXISTING BEARING REMOVAL DETAIL

Cost included with Jack and Remove Existing Bearings.

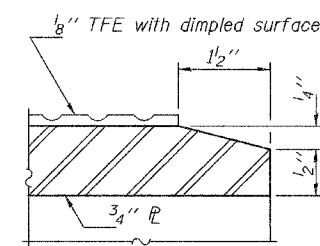

SECTION THRU TFE

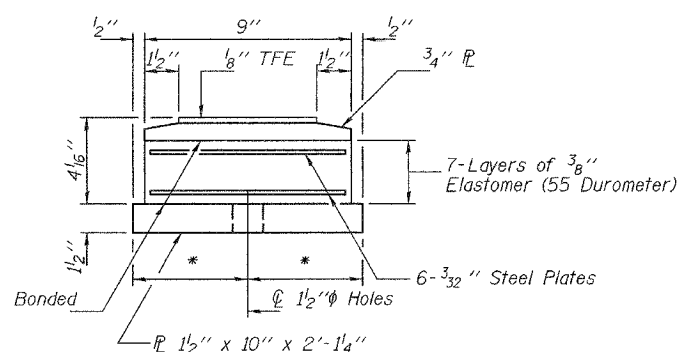

BOTTOM BEARING ASSEMBLY

* For hole location see Plan View of Bottom Bearing Plate

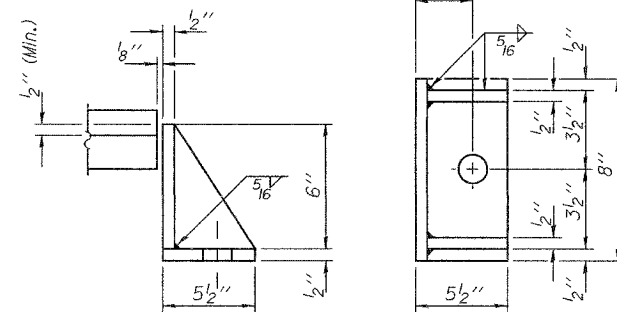

SIDE RETAINER

Equivalent rolled angle with stiffeners will be allowed in lieu of welded plates.

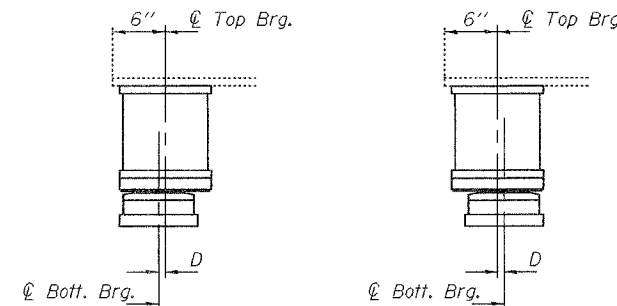

SETTING ANCHOR BOLTS AT EXP. BRG.
BELOW 50° F. (Move bott. brg. away from fixed brg.)
ABOVE 50° F. (Move bott. brg. toward fixed brg.)

SETTING ANCHOR BOLTS AT EXP. BRG.

D = 1/8" per each 100' of expansion for every 15° temp. change from the normal temp. of 50°F.

EAST ABUTMENT
BEAM REACTIONS

R _P	(K)	38.8
R _L	(K)	43.9
Imp.	(K)	11.0
R (Total)	(K)	93.7

WEST ABUTMENT
BEAM REACTIONS

R _P	(K)	35.1
R _L	(K)	44.7
Imp.	(K)	12.3
R (Total)	(K)	92.1

SHIM PLATES

SN 058-0095 at W. Abut.		
Girder 3	5/8" x 11" x 12"	
Girder 4	5/8" x 11" x 12"	
SN 058-0096 at W. Abut.		
Girder 4	1/4" x 11" x 12"	

BILL OF MATERIAL

Item	Unit	Total
Elastomeric Bearing Assembly Type II	Each	24
Jack and Remove Existing Bearings	Each	24
Furnishing and Erecting Structural Steel	Pound	3420
Anchor Bolts, 1"φ	Each	48

ABUTMENT BEARING
REPLACEMENT DETAILS

FAI RT. 72
MACON COUNTY
SN 058-0095 & 0096

DESIGNED	AJB
CHECKED	SJB
DRAWN	Steffen
CHECKED	AJB SJB

APRIL 18, 2008
EXAMINED *Carl Proyer*
ENGINEER OF STRUCTURAL SERVICES
PASSED *Ralph E. Anderson*
ENGINEER OF BRIDGES AND STRUCTURES

GENERAL NOTES

Reinforcement bars shall conform to the requirements of ASTM A 706 Br 60 (IL Modified). See Special Provisions.

Reinforcement bars designated (E) shall be epoxy coated.

Plan dimensions and details relative to existing plans are subject to routine variations. The Contractor shall field verify existing dimensions and details affecting new construction and make necessary approved adjustments prior to construction or ordering of materials. Such variations shall not be cause for additional compensations for a change in scope of the work; however, the Contractor will be paid for the quantity actually furnished based upon the unit price bid for the work.

Existing reinforcement bars extending into the removal area shall be cleaned, straightened and incorporated into the new construction. Any reinforcement bars that are damaged during concrete removal operations shall be repaired or replaced using an approved bar splicer or anchorage system. Cost Included In concrete removal.

Joint openings shall be adjusted according to Article 520.04 of the Standard Specifications when the deck is poured at an ambient temperature other than 50°F.

Prior to pouring the new concrete deck, all heavy or loose rust, loose mill scale, and other loose or potentially detrimental foreign material shall be removed from the surfaces in contact with concrete. Tightly adhered paint may remain unless otherwise noted. Removal shall be accomplished by methods that will not damage the steel and the cost will be included in the pay item covering removal of the existing concrete.

Removal and replacement of the end handrail sections and support posts at the east abutment will be necessary for construction of the expansion joints. The existing handrail sections and support posts shall be reused. New bolts, shim plates, and post support anchor assemblies as detailed in the plans are to be provided and installed for the replacement of the handrail and supports. This work and all materials shall be included in the contract unit price for Concrete Superstructure.

Areas of deck repairs shown are estimated. The Engineer shall show actual locations of deck repairs on as-built plans.

The existing waterproofing membrane system is not known to contain asbestos.

TOTAL BILL OF MATERIALS

SN 058-0097

ITEM DESCRIPTION	UNIT	QUANTITY
Concrete Removal	Cu. Yd.	12.0
Concrete Superstructure	Cu. Yd.	13.3
Reinforcement Bars, Epoxy Coated	Pound	3010
Bar Splicers	Each	24
Elastomeric Bearing Assembly Type II	Each	8
Furnishing and Erecting Structural Steel	Pound	1900
Jack and Remove Existing Bearings	Each	8
Hot-Mix Asphalt Removal (Deck)	Sq. Yd.	899
Bridge Deck Hydro-Scarification, 1/2"	Sq. Yd.	889
Bridge Deck Fly Ash or GGBF Slag Concrete Overlay, 2 1/4"	Sq. Yd.	899
Bridge Deck Grooving	Sq. Yd.	899
Protective Coat	Sq. Yd.	899
Deck Slab Repair (Full Depth Type I)	Sq. Yd.	4
Deck Slab Repair (Full Depth Type II)	Sq. Yd.	31
Floor Drains	Each	16
Preformed Joint Strip Seal	Foot	82
Structural Repair of Concrete <5"	Sq. Ft.	141
Plug Existing Deck Drains	Each	16
Anchor Bolts 1/2" Ø	Each	16
Protective Shield	Sq. Yd.	1036

The existing 2 span steel multi-beam structure was constructed in 1974 as section 58-66HB-1 at sta. 854+91.19. SN 058-0097 carries CH-18 over FAI-72. The proposed project consists of new expansion joints, partial and full depth deck patching, new wearing surface, new deck drains, remove and replace bearings at abutments, and structural repair of concrete.

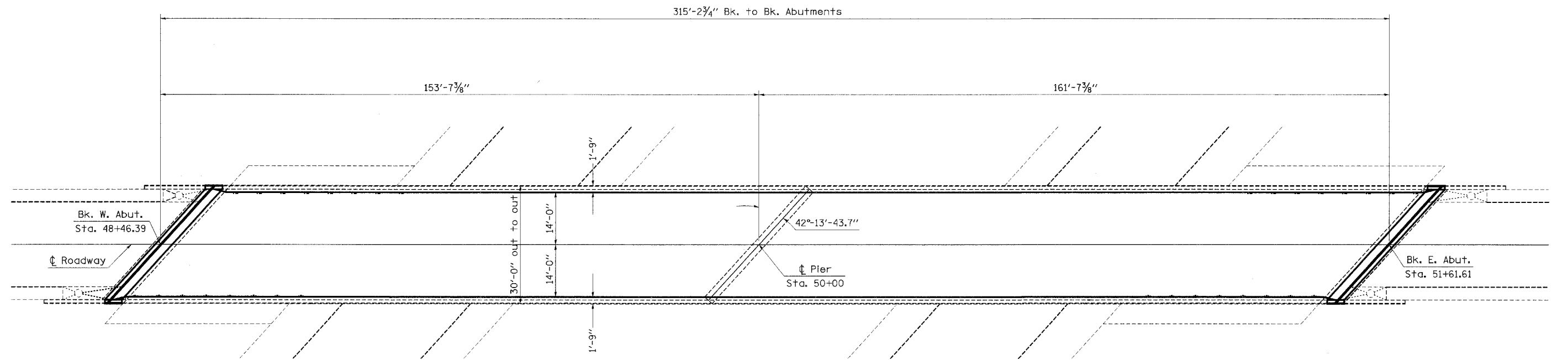
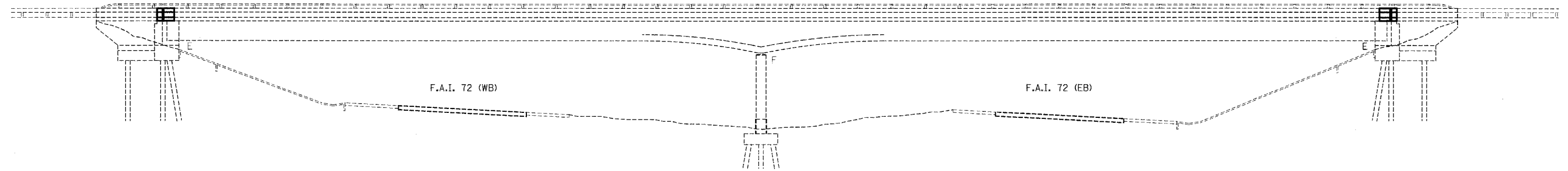

FILE NAME = ci\projects\74171d\karenbridge.dgn	USER NAME = swartzk	DESIGNED -	REVISED -
		DRAWN -	REVISED -
	PLOT SCALE = 20,0000 1/ IN.	CHECKED -	REVISED -
	PLOT DATE = 3/28/2008	DATE -	REVISED -

STATE OF ILLINOIS
DEPARTMENT OF TRANSPORTATION

GENERAL PLAN & ELEVATION
SN 058-0097
SCALE: N/A SHEET NO. 37 OF 52 SHEETS STA. TO STA.

F.A.I. RTE.	SECTION	COUNTY	TOTAL SHEETS	SHEET NO.
72	(58,74X66,67)RS-1	MACON	88	37
FED. ROAD DIST. NO.			ILLINOIS FED. AID PROJECT	

SHEET NO. 37 OF 52 SHEETS

Note: Trim existing long. reinf. to accomodate new joint opening (typ.)

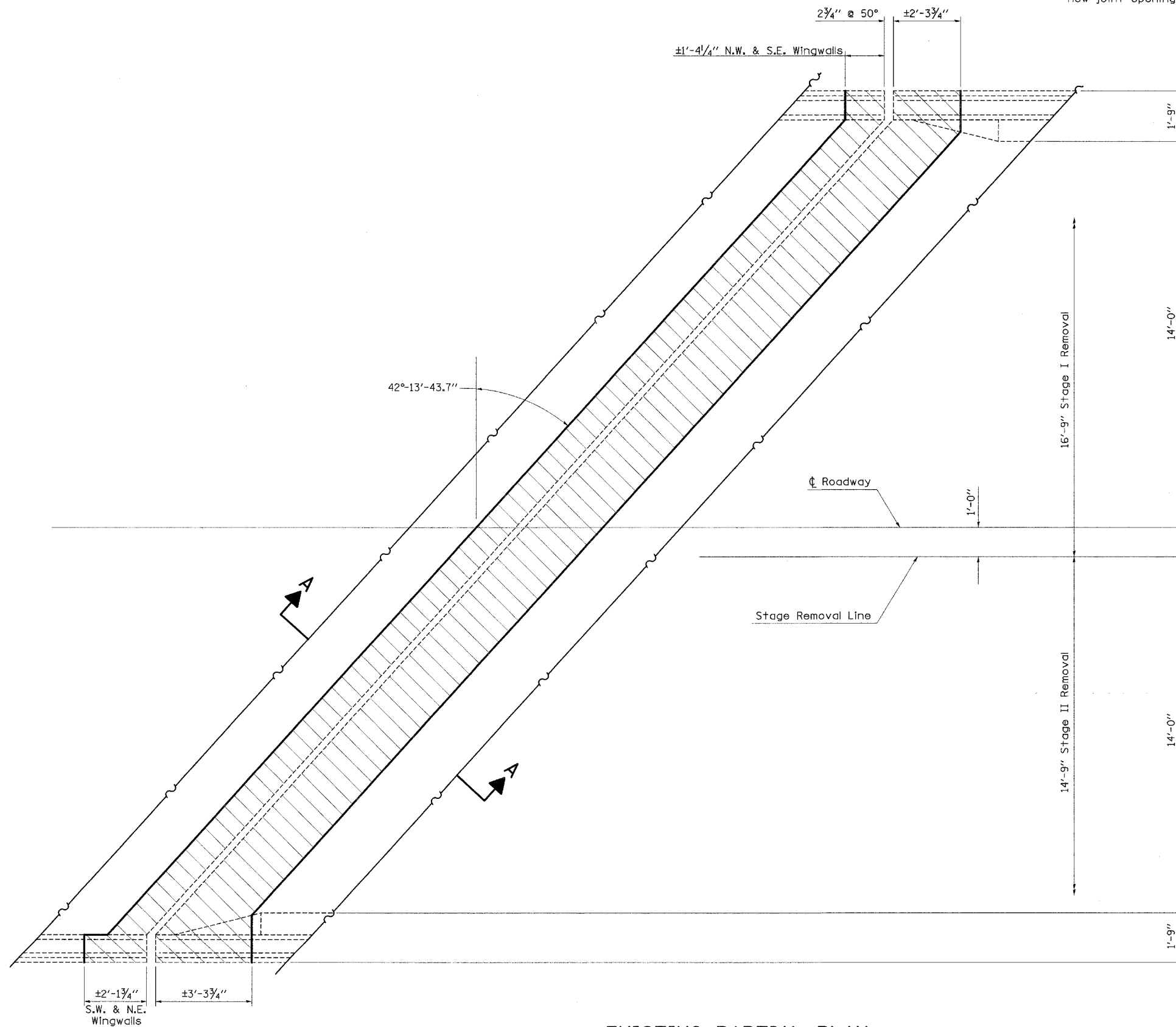

EXISTING PARTIAL PLAN
(West Abutment shown; East Abutment similar)

FILE NAME = c:\projects\7417\karanbridge.dgn	USER NAME = swartzw	DESIGNED -	REVISED -
	PLOT SCALE = 20.0000' / IN.	DRAWN -	REVISED -
	PLOT DATE = 3/20/2008	CHECKED -	REVISED -
		DATE -	REVISED -

**STATE OF ILLINOIS
DEPARTMENT OF TRANSPORTATION**

**EXPANSION JOINT REPLACEMENT DETAILS
SN 058-0097**

SCALE: N/A SHEET NO. 38 OF 52 SHEETS STA. TO STA.

F.A.I. RTE.	SECTION	COUNTY	TOTAL SHEETS	SHEET NO.
72	(58,74X66,67)RS-1	MACON	88	38
FED. ROAD DIST. NO.			ILLINOIS FED. AID PROJECT	

SHEET NO. 38 OF 52 SHEETS

CONTRACT NO. 741

BILL OF MATERIAL

BAR	NUMBER OF BARS		TOTAL	SIZE	LENGTH	SHAPE
	STAGE I	STAGE II				
a6(E)	16	16	32	#5	20' - 7"	—
a7(E)	6	6	12	#6	4' - 0"	—
d2(E)	2	2	4	#4	2' - 1"	□
d6(E)	7	7	14	#4	4' - 2"	J
d7(E)	7	7	14	#5	4' - 0"	J
h4(E)	8	8	16	#6	19' - 3"	—
x3(E)	38	38	72	#5	23' - 3"	□
CONCRETE REMOVAL					CU. YD.	12.0
REINFORCEMENT BARS (EPOXY COATED)					POUND	3010
CONCRETE SUPERSTRUCTURE					CU. YD.	13.3

REINFORCEMENT BARS DESIGNATED (E) SHALL BE EPOXY COATED

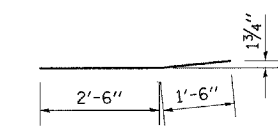

BAR a7(E)

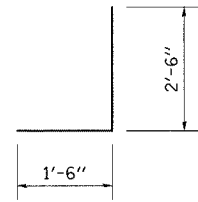

BAR d7(E)

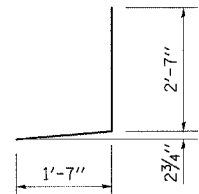

BAR d6(E)

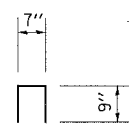

BAR d2(E)

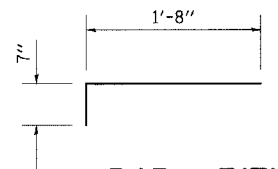

BAR x3(E)

±1'-3" S.W. & N.E. Wingwalls

±4'-2 1/2"

5 - #4 d6(E) bars at 12" cts. Outside Face
 5 - #5 d7(E) bars at 12" cts. Inside Face
 4 - #6 a7(E) bars at 15" cts. Top of Slab

2 - #6 h4(E) bars Top & Bottom

42°-13'-43.7"

2 - Bar Splicers for #6 bars T. & B.

2 - #6 h4(E) bars Top & Bottom

4 - Bar Splicers for #5 bars T. & B.

⊘ Roadway

4 - #5 a6(E) bars at ±6 1/2" cts. T. & B.

±2'-3" N.W. & S.E. Wingwall
 ±1'-4 7/8"

2 - #4 d2(E) bars at Rail Post
 E. Abut. only

2 - #4 d6(E) bars at 12" cts. Outside Face
 2 - #5 d7(E) bars at 12" cts. Inside Face
 2 - #6 a7(E) bars at 15" cts. Top of Slab

Field Bend

19 - #5 x3(E) bars at 12" cts.

15'-9" Stage I Construction

19 - #5 x3(E) bars at 12" cts.

15'-9" Stage II Construction

PROPOSED PARTIAL PLAN
 (West Abutment shown; East Abutment similar)



FILE NAME = c:\projects\74171d\kenenbridge.dgn	USER NAME = swartzrw	DESIGNED -	REVISED -
		DRAWN -	REVISED -
	PLOT SCALE = 20,000.00' / IN.	CHECKED -	REVISED -
	PLOT DATE = 3/28/2008	DATE -	REVISED -

STATE OF ILLINOIS
DEPARTMENT OF TRANSPORTATION

EXPANSION JOINT REPLACEMENT DETAILS
SN 058-0097

SCALE: N/A SHEET NO. 39 OF 52 SHEETS STA. TO STA.

F.A.I. RTE. 72	SECTION (58,74X66,67)RS-1	COUNTY MACON	TOTAL SHEETS 88	SHEET NO. 39
FED. ROAD DIST. NO. ILLINOIS FED. AID PROJECT			CONTRACT NO. 741	

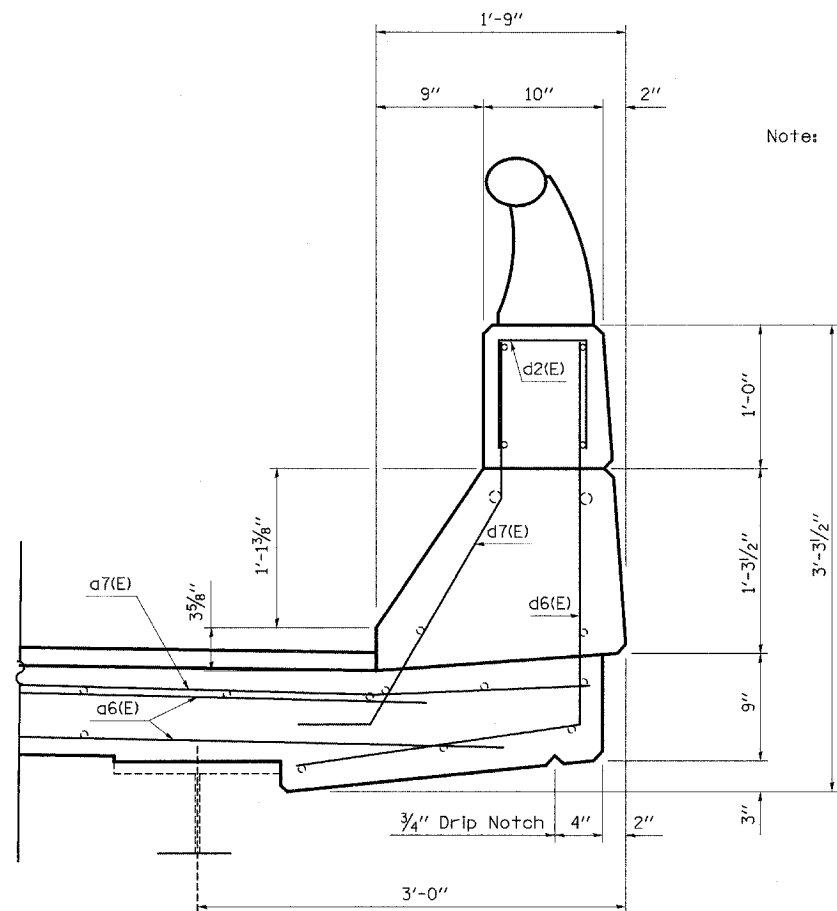

SECTION THRU PARAPET

Note: Rotate d6(E) and d7(E) bars in parapet to fit horizontal legs in concrete pour.

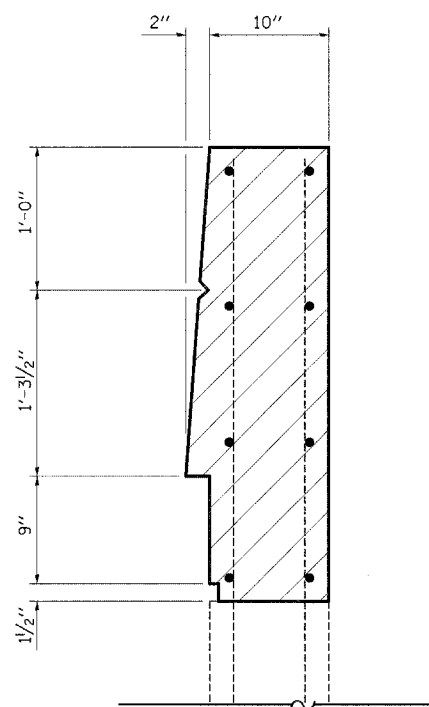

SECTION THRU WINGWALL

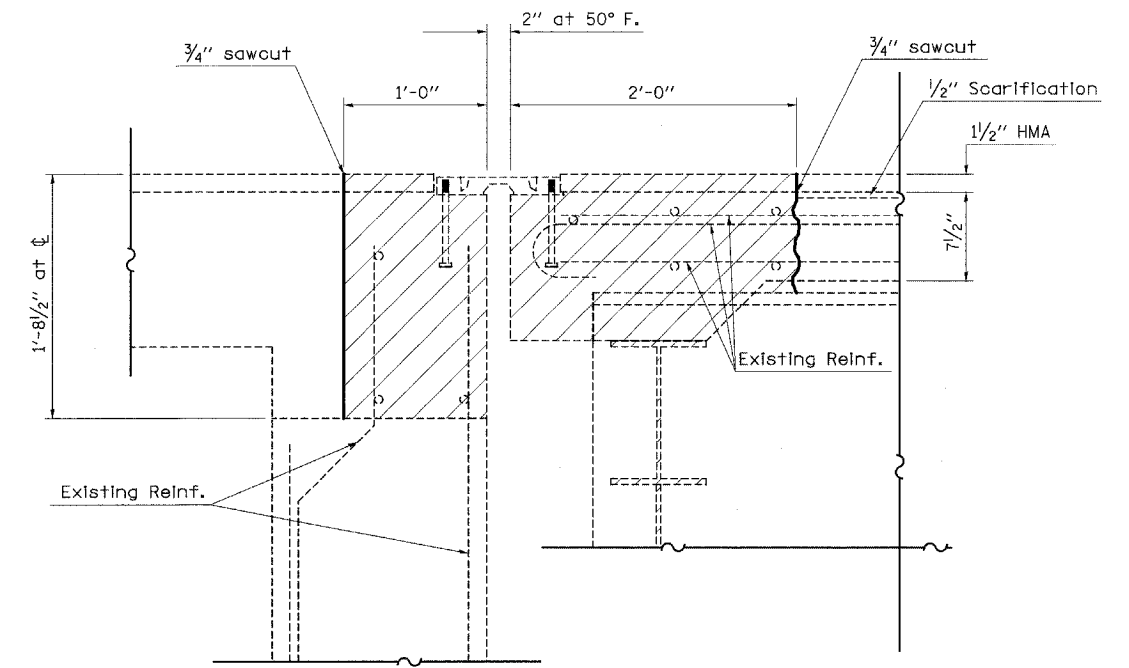

SECTION A-A
(Dimensions at RT L's to end of deck)

For details of expansion joint
See sheet 51 of 52

- Existing Reinforcement
- Proposed Reinforcement

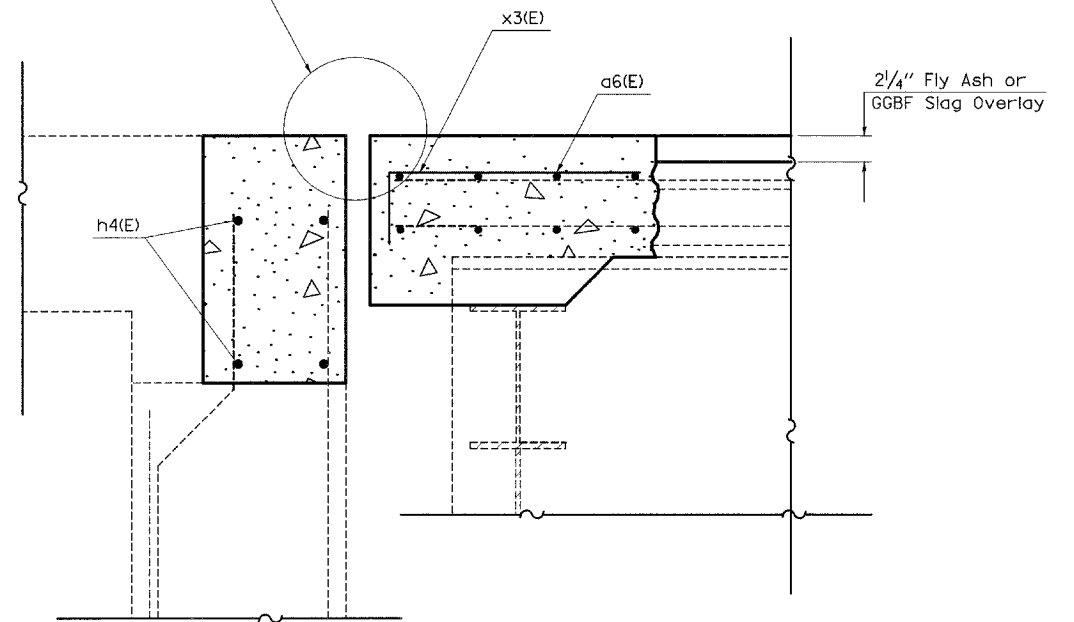

SECTION B-B
(Dimensions at RT L's to end of deck)

FILE NAME = c:\projects\74171d\karenbr\idgedgn	USER NAME = swartzw	DESIGNED -	REVISED -
		DRAWN -	REVISED -
	PLOT SCALE = 28,0000' / IN.	CHECKED -	REVISED -
	PLOT DATE = 3/20/2008	DATE -	REVISED -

**STATE OF ILLINOIS
DEPARTMENT OF TRANSPORTATION**

RAIL SUPPORT ANCHOR DETAILS

SCALE: N/A SHEET NO. 40 OF 52 SHEETS STA. TO STA.

F.A.I. RTE.	SECTION	COUNTY	TOTAL SHEETS	SHEET NO.
72	(58,74X66,67)RS-1	MACON	88	40
FED. ROAD DIST. NO.			ILLINOIS FED. AID PROJECT	

SHEET NO. 52 SHEET

CONTRACT NO. 741

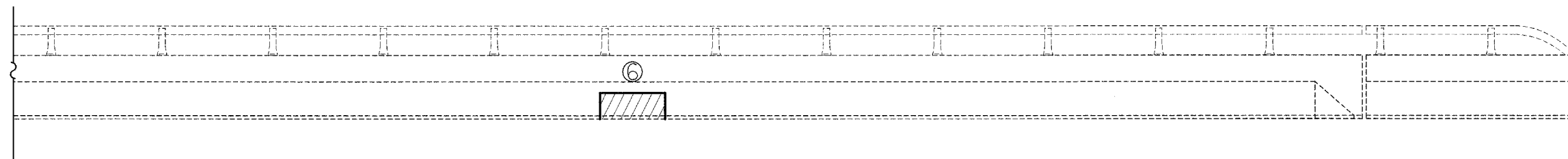
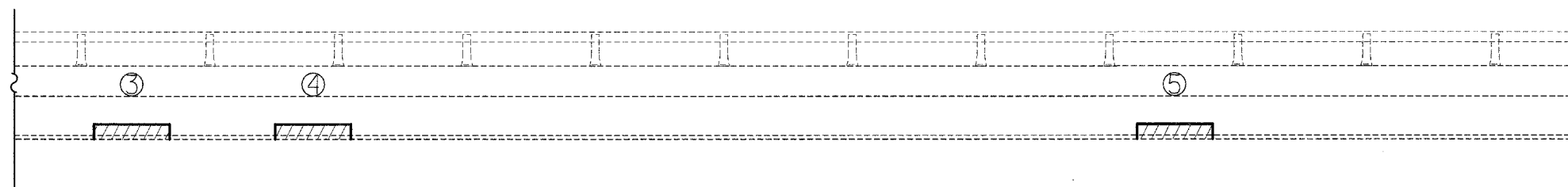
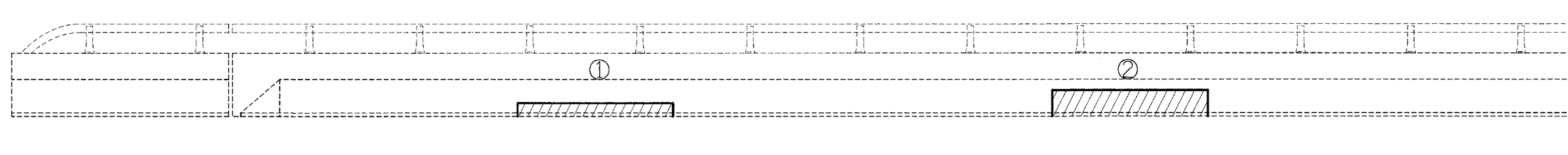

STRUCTURAL REPAIR

Cost included in Structural Repair of Concrete (Depth <5')

PATCH NUMBER	STATION	AREA SQ. FT.
1	48+80	6.0
2	49+34	12.0
3	49+73	3.0
4	49+85	3.0
5	50+42	3.0
6	51+17	5.0
	Total	32.0

NORTH PARAPET

Looking North

FILE NAME = c:\projects\74171d\kar-enbridge.dgn

USER NAME = swartzw

PLOT SCALE = 20,0000 1/ IN.

PLOT DATE = 3/28/2008

DESIGNED -

DRAWN -

CHECKED -

DATE -

REVISED -

REVISED -

REVISED -

REVISED -

**STATE OF ILLINOIS
DEPARTMENT OF TRANSPORTATION**

**STRUCTURAL REPAIR - PARAPET
SN 058-0097**

SCALE: N/A

SHEET NO. 41 OF 52 SHEETS

STA.

TO STA.

F.A.I. RTE.

72

SECTION

(58,74X66,67)RS-1

COUNTY

MACON

SHEET NO.

52 SHEETS

TOTAL SHEETS

88

CONTRACT NO. 741

FED. ROAD DIST. NO.

ILLINOIS FED. AID PROJECT

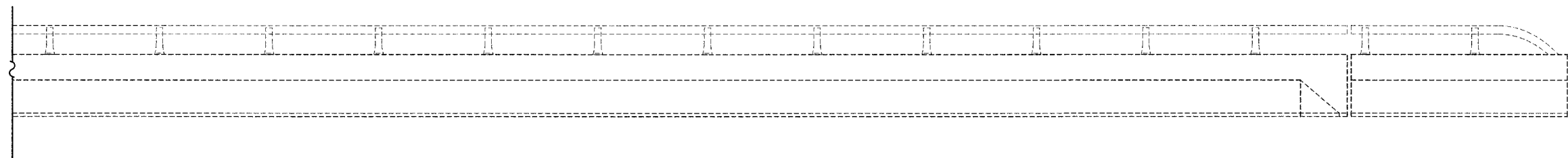
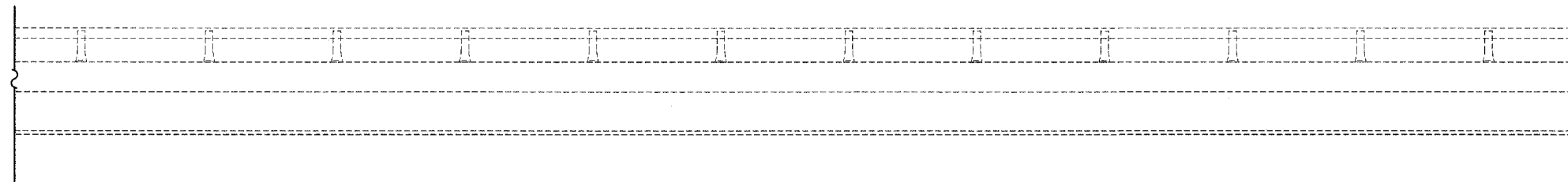
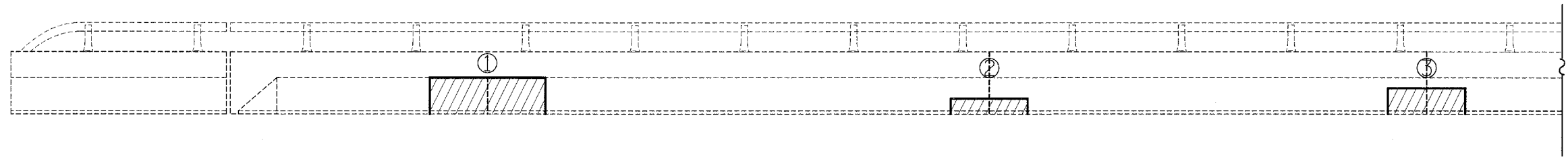

STRUCTURAL REPAIR

Cost Included In Structural Repair
of Concrete (Depth <5')

PATCH NUMBER	STATION	AREA SQ. FT.
1	51+27	14.0
2	50+88	4.0
3	50+54	6.0
	Total	24.0

SOUTH PARAPET

Looking South

FILE NAME = c:\projects\74171a\k.arenbridge.dgn	USER NAME = swartzw	DESIGNED -	REVISED -
		DRAWN -	REVISED -
	PLOT SCALE = 20,0000 ' / IN.	CHECKED -	REVISED -
	PLOT DATE = 3/28/2008	DATE -	REVISED -

**STATE OF ILLINOIS
DEPARTMENT OF TRANSPORTATION**

**STRUCTURAL REPAIR - PARAPET
SN 058-0097**

SCALE: N/A SHEET NO. 42 OF 52 SHEETS STA. TO STA.

F.A.I. RTE.	SECTION	COUNTY	TOTAL SHEETS	SHEET NO.
72	(58,74X66,67)RS-1	MACON	88	42
FED. ROAD DIST. NO.			ILLINOIS FED. AID PROJECT	

SHEET NO.

52 SHEETS

CONTRACT NO. 741

NOTE: QUANTITIES ARE ESTIMATED. ACTUAL QUANTITIES TO BE DETERMINED BY THE RESIDENT ENGINEER.

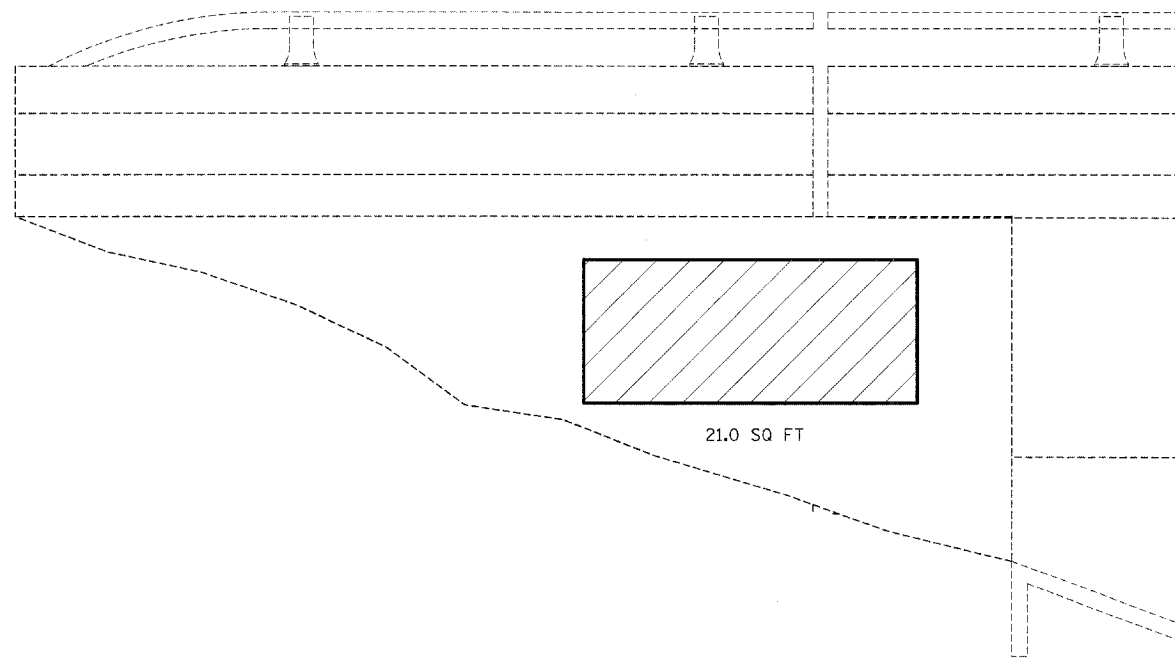

NORTHEAST WING

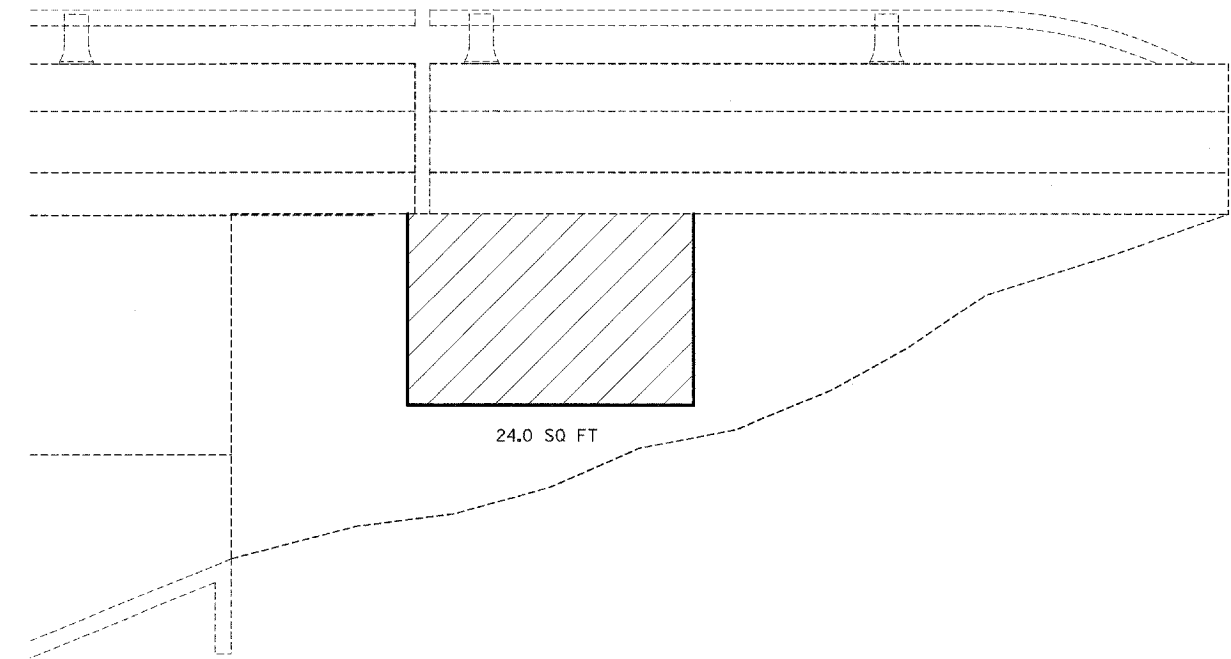

SOUTHEAST WING

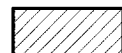

Structural Repair of Concrete (Depth < 5")

FILE NAME = c:\projects\74171d\korenbridge.dgn	USER NAME = swartzrw	DESIGNED -	REVISED -
		DRAWN -	REVISED -
	PLOT SCALE = 20.0000 ' / IN.	CHECKED -	REVISED -
	PLOT DATE = 3/20/2008	DATE -	REVISED -

**STATE OF ILLINOIS
DEPARTMENT OF TRANSPORTATION**

**STRUCTURAL REPAIR - EAST ABUTMENT
SN 058-0097**

SCALE: N/A SHEET NO. 43 OF 52 SHEETS STA. TO STA.

F.A.I. RTE.	SECTION	COUNTY	TOTAL SHEETS	SH N
72	(58,74X66,67)RS-1	MACON	88	6
FED. ROAD DIST. NO. ILLINOIS FED. AID PROJECT			CONTRACT NO. 741	

SHEET NO.
52 SHEETS

NOTE: QUANTITIES ARE ESTIMATED. ACTUAL QUANTITIES TO BE DETERMINED BY THE RESIDENT ENGINEER.

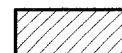
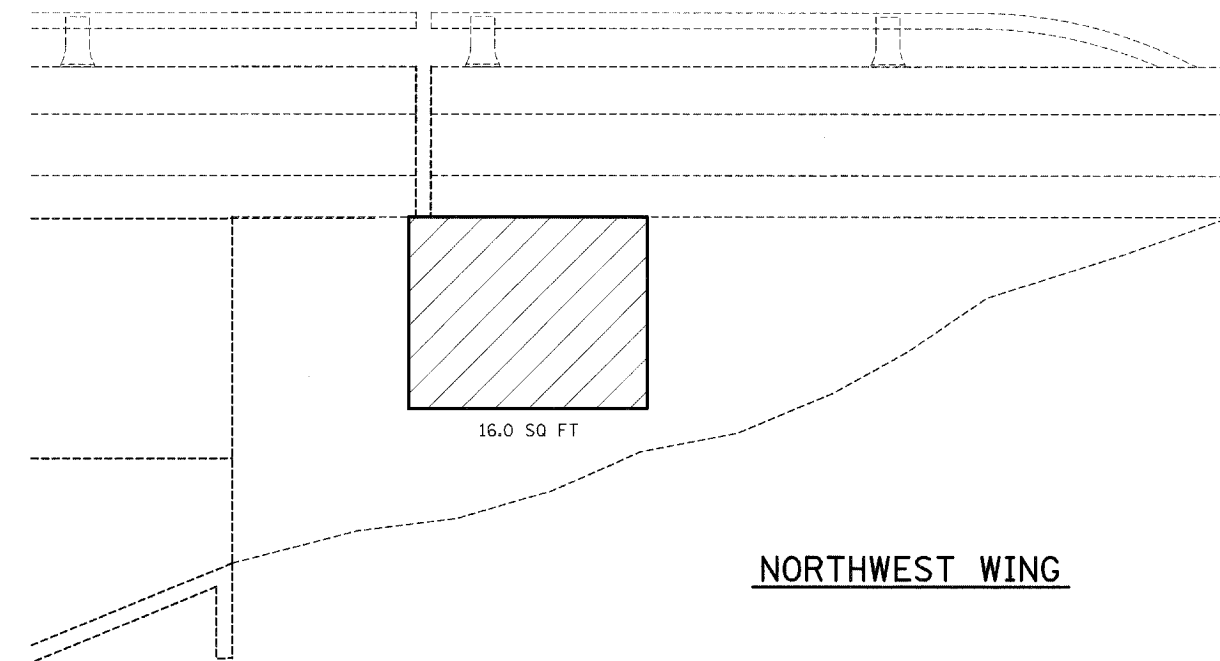
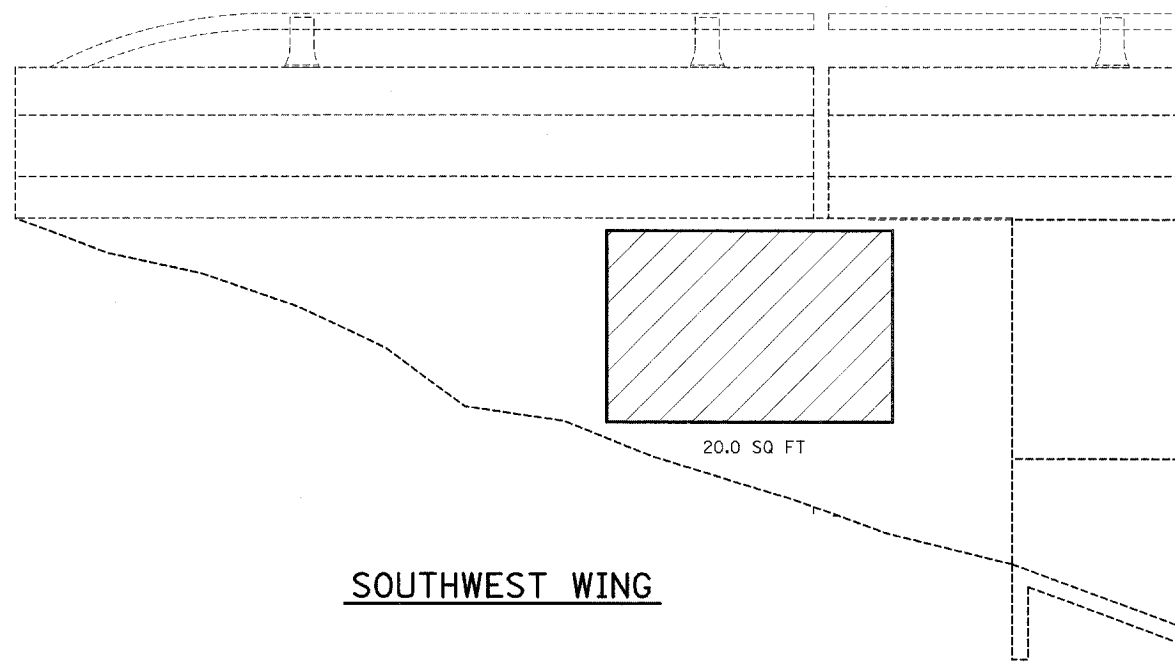

Structural Repair of Concrete (Depth < 5")

FILE NAME = c:\projects\174171d\karenbridge.dgn	USER NAME = swartzrw	DESIGNED -	REVISED -
		DRAWN -	REVISED -
	PLOT SCALE = 20,0000 ' / IN.	CHECKED -	REVISED -
	PLOT DATE = 3/20/2008	DATE -	REVISED -

**STATE OF ILLINOIS
DEPARTMENT OF TRANSPORTATION**

**STRUCTURAL REPAIR - WEST ABUTMENT
SN 058-0097**

SCALE: N/A SHEET NO. 44 OF 52 SHEETS STA. TO STA.

F.A.I. RTE.	SECTION	COUNTY	TOTAL SHEETS	SHEET NO.
72	(58,74X66,67)RS-1	MACON	88	44
FED. ROAD DIST. NO. ILLINOIS FED. AID PROJECT			CONTRACT NO. 741	

SHEET NO. 52 SHEET

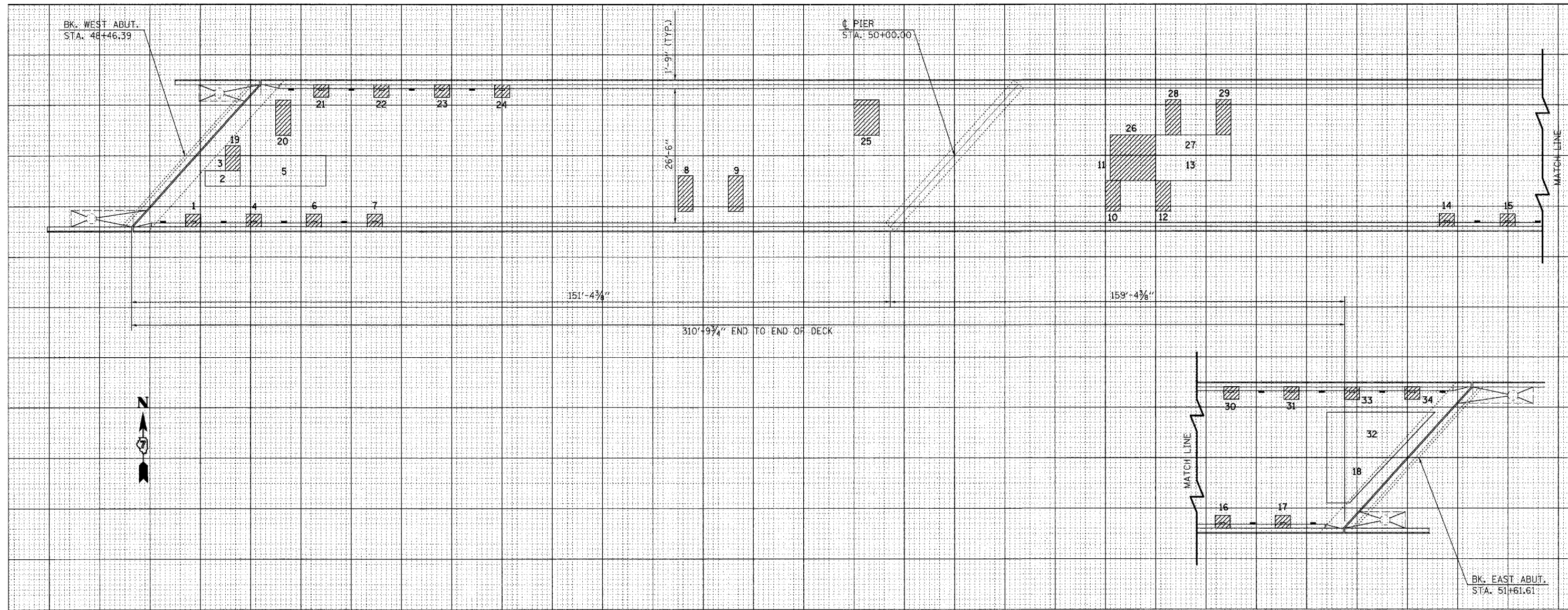

PATCH NO.	SIZE	DECK SLAB REPAIR (PART DEPTH)			PATCH NO.	SIZE	DECK SLAB REPAIR (PART DEPTH)			PATCH NO.	SIZE	DECK SLAB REPAIR (PART DEPTH)			PATCH NO.	SIZE	DECK SLAB REPAIR (PART DEPTH)		
		SQ FT	SQ FT	SQ FT			SQ FT	SQ FT	SQ FT			SQ FT	SQ FT	SQ FT			SQ FT	SQ FT	SQ FT
1	1.8 x 1.2		2.2		19	3.0 x 2.0			6.0										
2	7.0 x 3.0	21.0			20	3.0 x 7.0			21.0										
3	3.0 x 3.0			9.0	21	1.8 x 1.2		2.2											
4	1.8 x 1.2		2.2		22	1.8 x 1.2		2.2											
5	17.0 x 6.0	102.0			23	1.8 x 1.2		2.2											
6	1.8 x 1.2		2.2		24	1.8 x 1.2		2.2											
7	1.8 x 1.2		2.2		25	5.0 x 7.0			35.0										
8	3.0 x 7.0			21.0	26	9.0 x 4.0			36.0										
9	3.0 x 7.0			21.0	27	15.0 x 4.0	60.0												
10	3.0 x 6.0			18.0	28	3.0 x 7.0			21.0										
11	9.0 x 5.0			45.0	29	3.0 x 7.0			21.0										
12	3.0 x 6.0			18.0	30	1.8 x 1.2		2.2											
13	15.0 x 5.0	75.0			31	1.8 x 1.2		2.2											
14	1.8 x 1.2		2.2		32	17.3 x 9.0	155.3												
15	1.8 x 1.2		2.2		33	1.8 x 1.2		2.2											
16	1.8 x 1.2		2.2		34	1.8 x 1.2		2.2											
17	3.0 x 2.5			7.5															
18	9.3 x 9.0	83.3			TOTAL		497	33	280	0									

THE LOCATIONS AND SIZES SHOWN GRAPHICALLY ABOVE ARE APPROXIMATE. SEE THE TABLE FOR ACTUAL SIZES.

PATCHING LEGEND

- PARTIAL DEPTH (FOR INFORMATION ONLY)
- FULL DEPTH
- FLOOR DRAIN TO BE REPLACED
- FLOOR DRAIN TO BE PLUGGED

DATE OF SURVEY: 10/17/00
SURVEY BY: M. ALLEN, K. THOMAS
METHOD OF SURVEY: VISUAL

BRIDGE DECK PATCHING
MACON COUNTY

SHEET NO. 45
52 SHEETS

097

STATE OF ILLINOIS
DEPARTMENT OF TRANSPORTATION

ROUTE NO.	SECTION	COUNTY	DISTRICT	SHEET	SHEET NO. 1
FAI 72		MACON	88	71	2 SHEETS
FED. ROAD DIST. NO. 7	ILLINOIS	FED. AID PROJECT			

Contract Number: 74171

NOTES

All structural steel shall conform to AASHTO Classification M-270 Gr. 36, unless otherwise noted.

Plan dimensions and details relative to existing plans are subject to routine variations. The Contractor shall field verify existing dimensions and details affecting new construction and make necessary approved adjustments prior to construction or ordering of materials. Such variations shall not be cause for additional compensation for a change in scope of the work, however, the Contractor will be paid for the quantity actually furnished based upon the unit price bid for the work.

If the analysis submitted to the Contractor for the jacking/temporary support system to be used shows temporary stiffeners are required to prevent web crippling or buckling, the stiffeners shall be steel and bolted to the web. If stiffeners are not required, hardwood timbers shall be installed tightly between the top and bottom flange to prevent flange rotation.

The existing structural steel coating contains lead. The Contractor shall take appropriate precautions to deal with the presence of lead on this project.

Existing structural steel that will be in contact with new structural steel shall be cleaned and painted prior to erection as required by the Special Provision "Cleaning and Painting Contact Surface Areas of Existing Steel Structures".

All structural steel shall be shop painted with the inorganic zinc rich primer per AASHTO M300, Type 1. Cost included with Furnishing and Erecting Structural Steel.

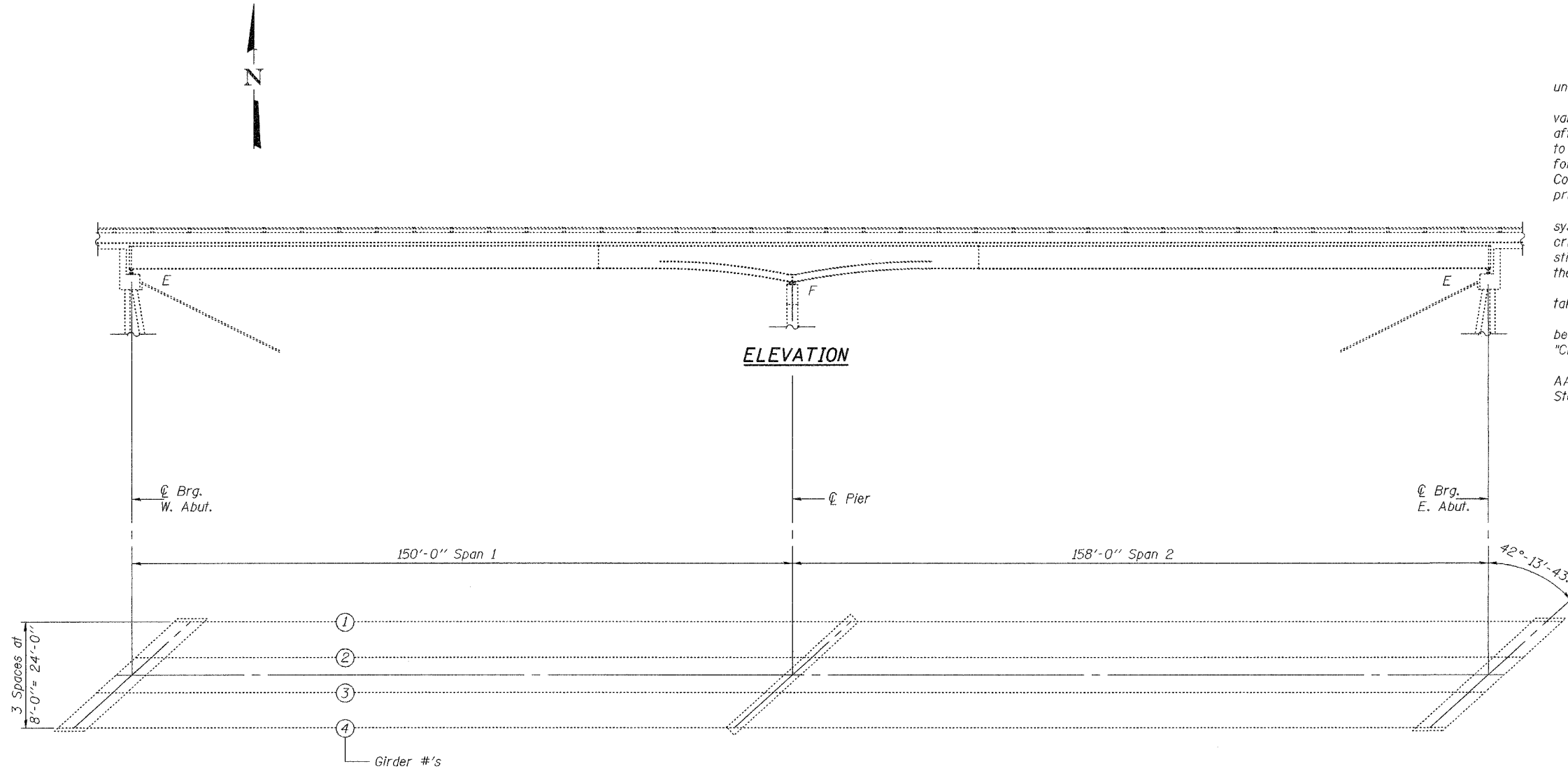

ELEVATION

PLAN

Remove and Replace Bearings at Abutments

BILL OF MATERIAL

ITEM	UNIT	TOTAL
Furnishing & Erecting Structural Steel	Pound	1900
Anchor Bolts, 1 1/2" φ	Each	16
Elastomeric Bearing Assembly, Type I	Each	8
Jack and Remove Existing Bearings	Each	8

**BEARING REPLACEMENT
PLAN & ELEVATION
CH. 18 OVER FAI RT. 72
MACON COUNTY
SN 058-0097**

DESIGNED	<i>[Signature]</i>
CHECKED	<i>[Signature]</i>
DRAWN	Steffen
CHECKED	115 558

APRIL 18, 2008
EXAMINED *[Signature]*
PASSED *[Signature]*
ENGINEER OF STRUCTURAL SERVICES
ENGINEER OF BRIDGES AND STRUCTURES



EXPIRES 11-30-2008

STATE OF ILLINOIS
DEPARTMENT OF TRANSPORTATION

ROUTE NO.	SECTION	COUNTY	POST MILE	POST MILE	SHEET NO. 2
FAI 72		MACON	88	72	2 SHEETS
FED. ROAD DIST. NO. 7	ILLINOIS	FED. AID PROJECT-			

Contract Number: 74171

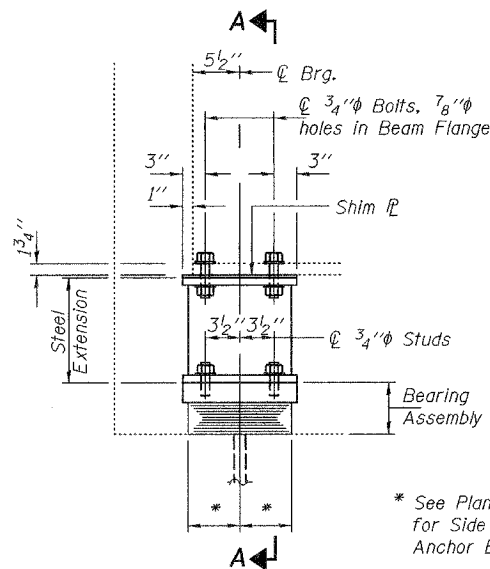

ELEVATION AT ABUTMENTS

TYPE I ELASTOMERIC EXP. BRG.

* See Plan View Detail for Side Retainer and Anchor Bolt placement

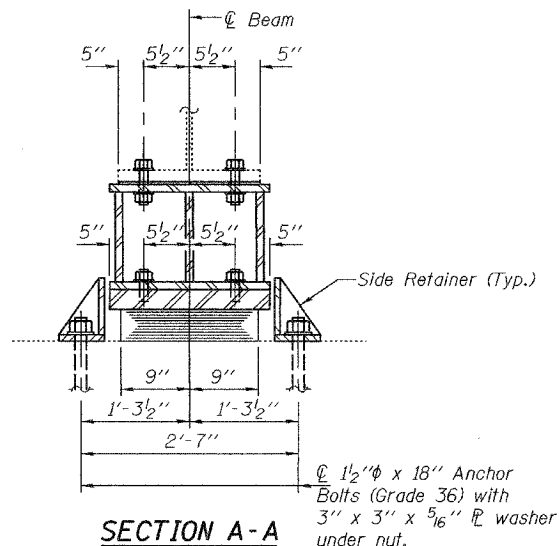

SECTION A-A

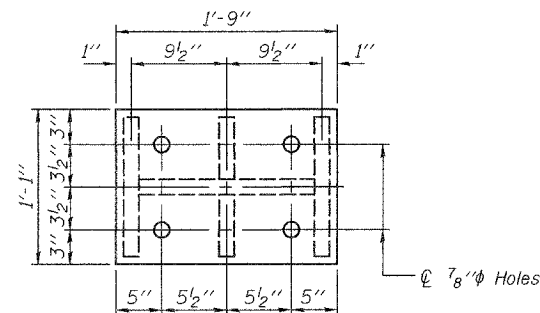

PLAN TOP AND BOTTOM PLATE

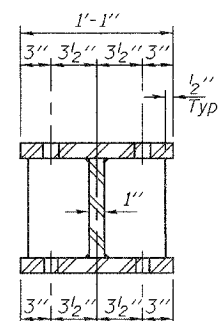

SECTION B-B

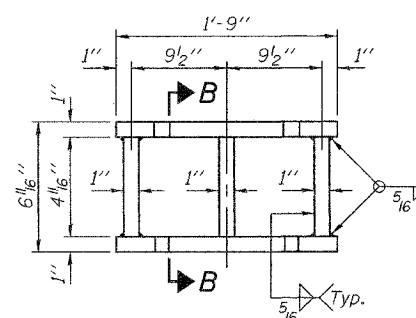

STEEL EXTENSION DETAIL

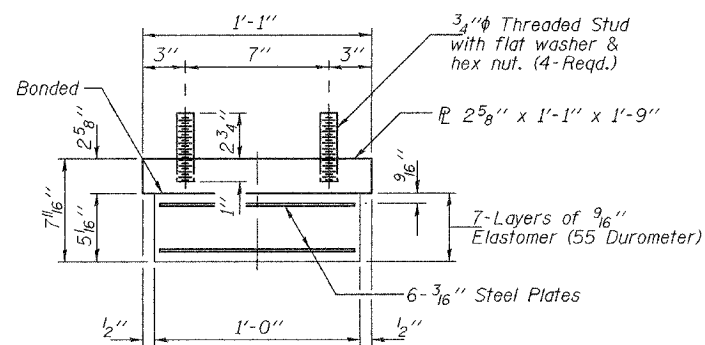

BEARING ASSEMBLY

Note:
Shim plates shall not be placed under Bearing Assembly.

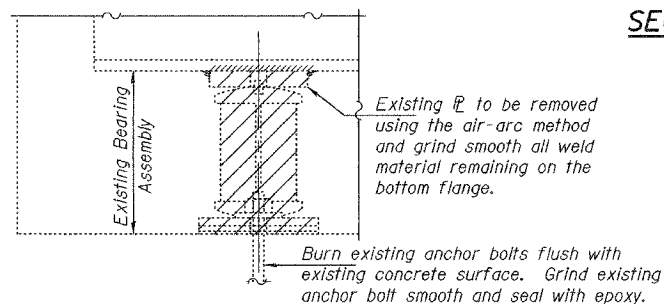

EXISTING BEARING REMOVAL DETAIL

Cost included with Jack and Remove Existing Bearings.

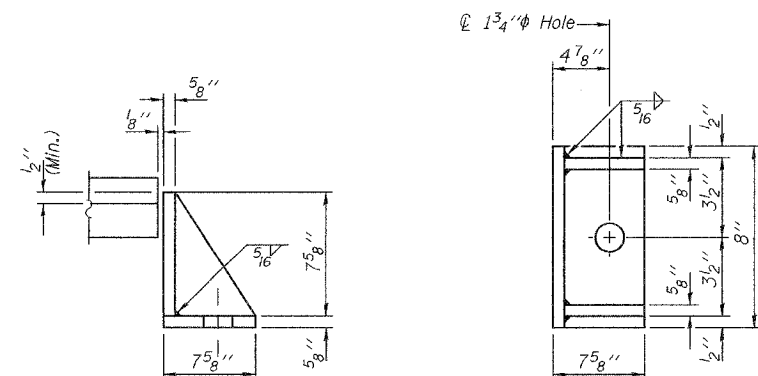

SIDE RETAINER

Equivalent rolled angle with stiffeners will be allowed in lieu of welded plates.

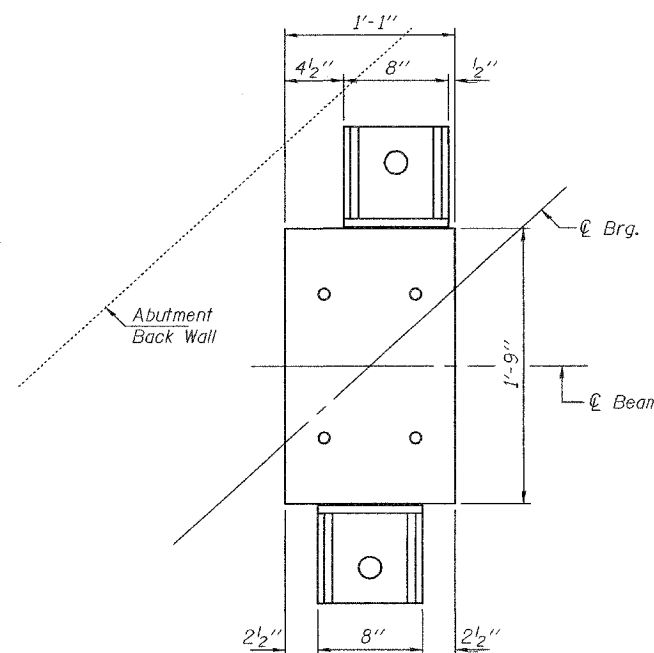

PLAN VIEW SHOWING PLACEMENT OF SIDE RETAINERS

Notes:
Diaphragm removal and installation may be required to facilitate drilling holes. Cost included with Furnishing and Erecting Structural Steel.
New steel extensions, shim plates and connection bolts are included with Furnishing and Erecting Structural Steel.
Prior to ordering any material, the Contractor shall verify in the field all bearing height and shim thickness dimensions. Min. jack capacity = 80 Tons for the West Abutment and 90 Tons for the East Abutment.
Anchor bolts shall be ASTM F1554 all-thread (or an Engineer-approved alternate material) of the grade(s) and diameter(s) specified. ASTM A307 Grade C anchor bolts may be used in lieu of ASTM F1554 Grade 36 (Fy=36ksi). The corresponding specified grade of AASHTO M314 anchor bolts may be used in lieu of ASTM F1554.
Side retainers shall be included in the cost of Elastomeric Bearing Assembly, Type I.
Drilled and set anchor bolts shall be installed according to Article 521.06 of the Standard Specifications.

SHIM PLATES

WEST ABUTMENT	
Girder 1	1/4" x 13" x 21"

EAST ABUTMENT	
Girder 3	3/8" x 13" x 21"

WEST ABUTMENT BEAM REACTIONS

R _P	(K)	84.8
R _L	(K)	37.2
Imp.	(K)	6.7
R (Total)	(K)	128.7

EAST ABUTMENT BEAM REACTIONS

R _P	(K)	93.5
R _L	(K)	38.4
Imp.	(K)	6.9
R (Total)	(K)	138.8

BILL OF MATERIAL

Item	Unit	Total
Elastomeric Bearing Assembly Type I	Each	8
Jack and Remove Existing Bearings	Each	8
Furnishing and Erecting Structural Steel	Pound	1900
Anchor Bolts, 1 1/2"φ	Each	16

ABUTMENT BEARING REPLACEMENT DETAILS
CH. 18 OVER FAI RT. 72
MACON COUNTY
SN 058-0097

DESIGNED	AJB
CHECKED	SJB
DRAWN	Steffen
CHECKED	AJB SJB

APRIL 18, 2008
EXAMINED *Carl Proyer*
ENGINEER OF STRUCTURAL SERVICES
PASSED *Ralph E. Anderson*
ENGINEER OF BRIDGES AND STRUCTURES

• Dimension as required by Pipe Clamp

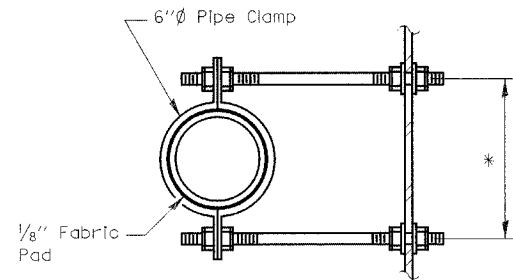

SECTION A-A

1/2" ϕ x 8" Fiberglass Reinf. Plastic Rebar

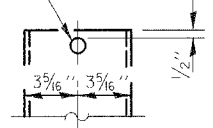

FIBERGLASS PIPE

Fill slot with weld
1/2" ϕ x 8" Alum. Bar
ASTM B 211 alloy 6061-T6

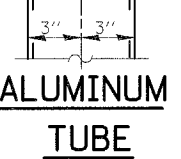

ALUMINUM TUBE

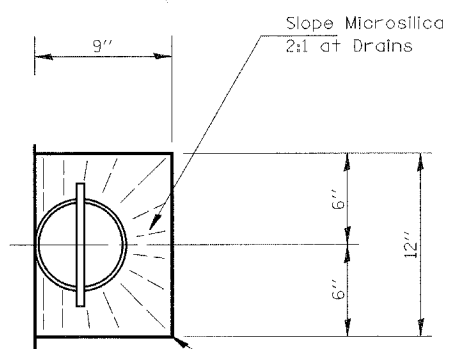

TOP PLAN

Surface of Original Concrete Deck

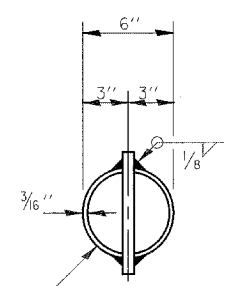

TOP PLAN
(Showing Aluminum Tube)

6" O.D. Aluminum Tube alloy 6061-T6 or 6" ϕ Fiberglass Pipe

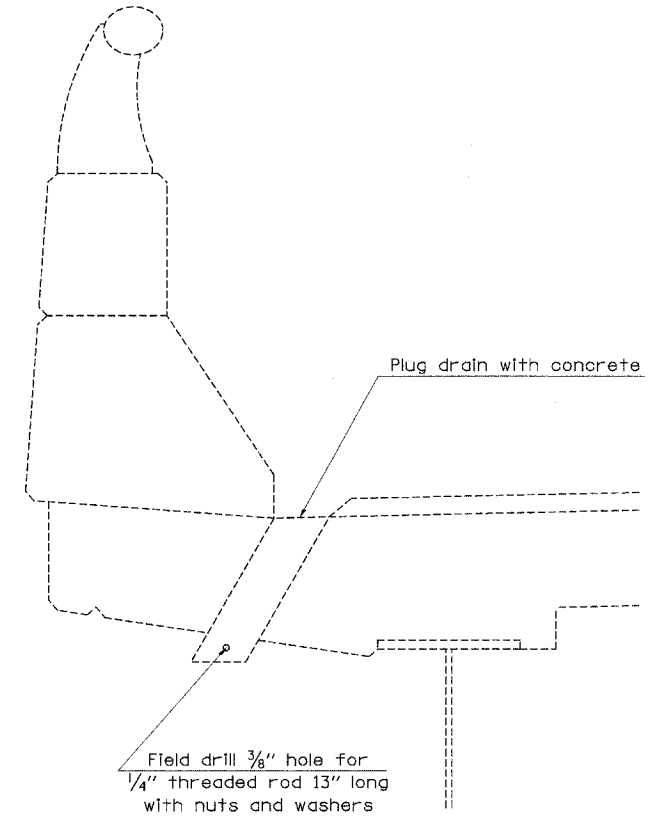

DRAINS TO BE PLUGGED DETAIL

Note: Fiberglass pipe shall conform to ASTM D 2996, with short-time rupture strength hoop tensile stress of 30,000 p.s.i. minimum.

Note: See "Bridge Deck Patching" plan sheets for Plug Existing Deck Drains locations. See "Total Bill of Materials" for each structure for quantities.

• Dimensions shall be determined by the Engineer in the field based on extent of deck deterioration at each drain.

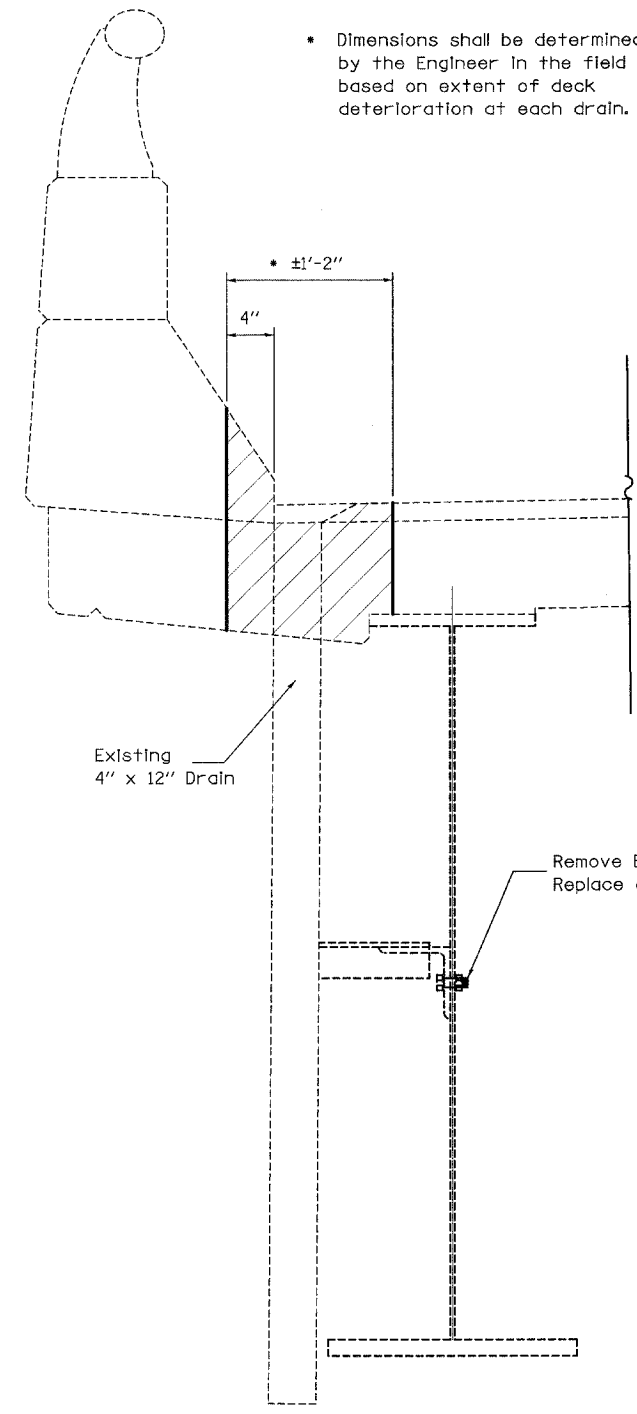

SECTION THRU EXISTING FLOOR DRAIN

Hatched area indicates concrete removal at floor drain replacement.

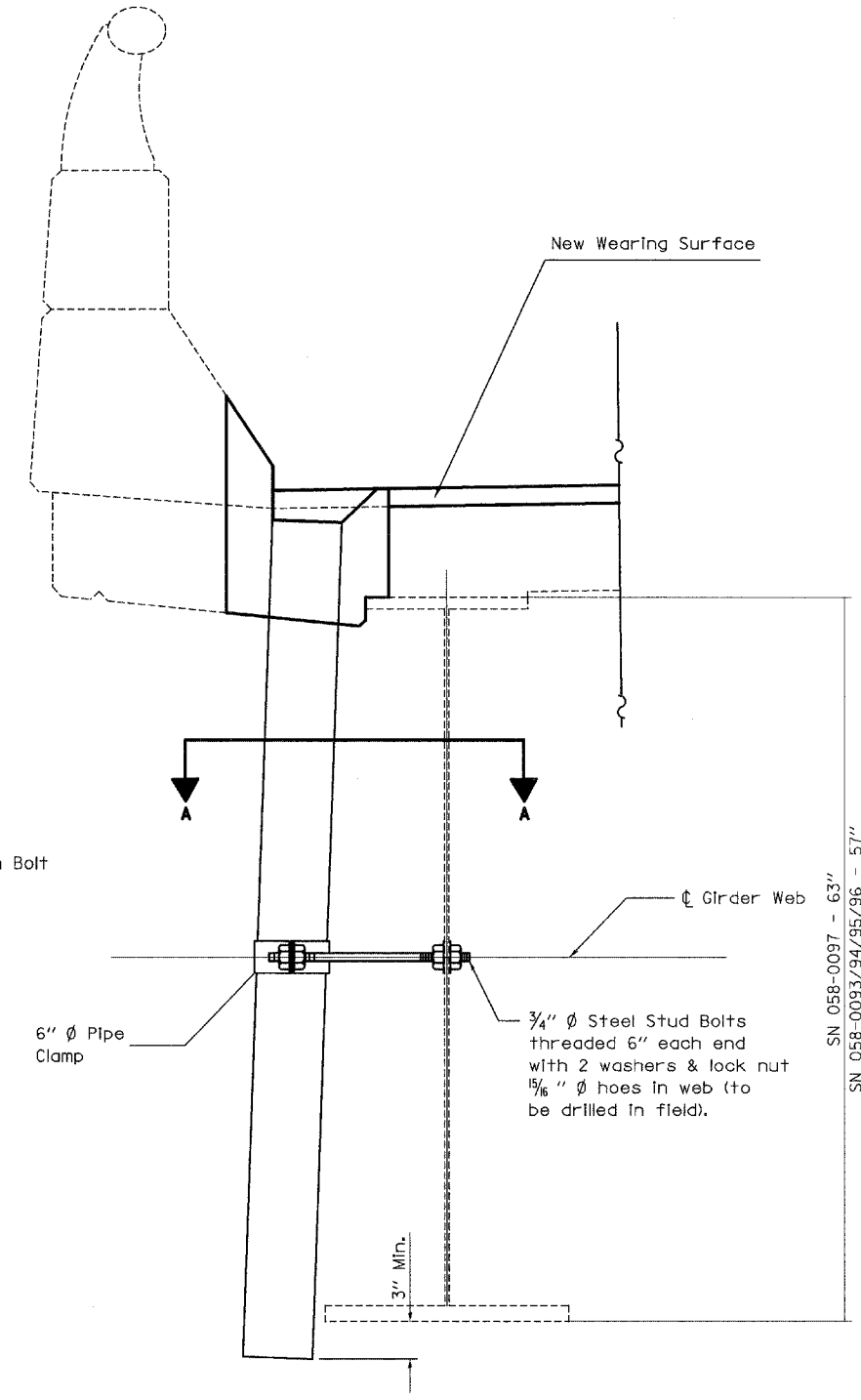

DRAIN REPLACEMENT DETAIL

Note: See "Bridge Deck Patching" plan sheets for Floor Drain replacement locations. See "Total Bill of Materials" for each structure for quantities.

FILE NAME = c:\projects\74171d\korenbridge.dgn	USER NAME = swartzw	DESIGNED -	REVISED -
		DRAWN -	REVISED -
	PLOT SCALE = 20,0000' / IN.	CHECKED -	REVISED -
	PLOT DATE = 3/20/2005	DATE -	REVISED -

**STATE OF ILLINOIS
DEPARTMENT OF TRANSPORTATION**

FLOOR DRAIN DETAIL
SCALE: N/A SHEET NO. 48 OF 52 SHEETS STA. TO STA.

F.A.I. RTE. 72	SECTION (58,74X66,67)RS-1	COUNTY MACON	TOTAL SHEETS 88	SHEET NO. 7
FED. ROAD DIST. NO.		ILLINOIS FED. AID PROJECT		

SN 058-0097 - 63"
SN 058-0093/94/95/96 - 57"

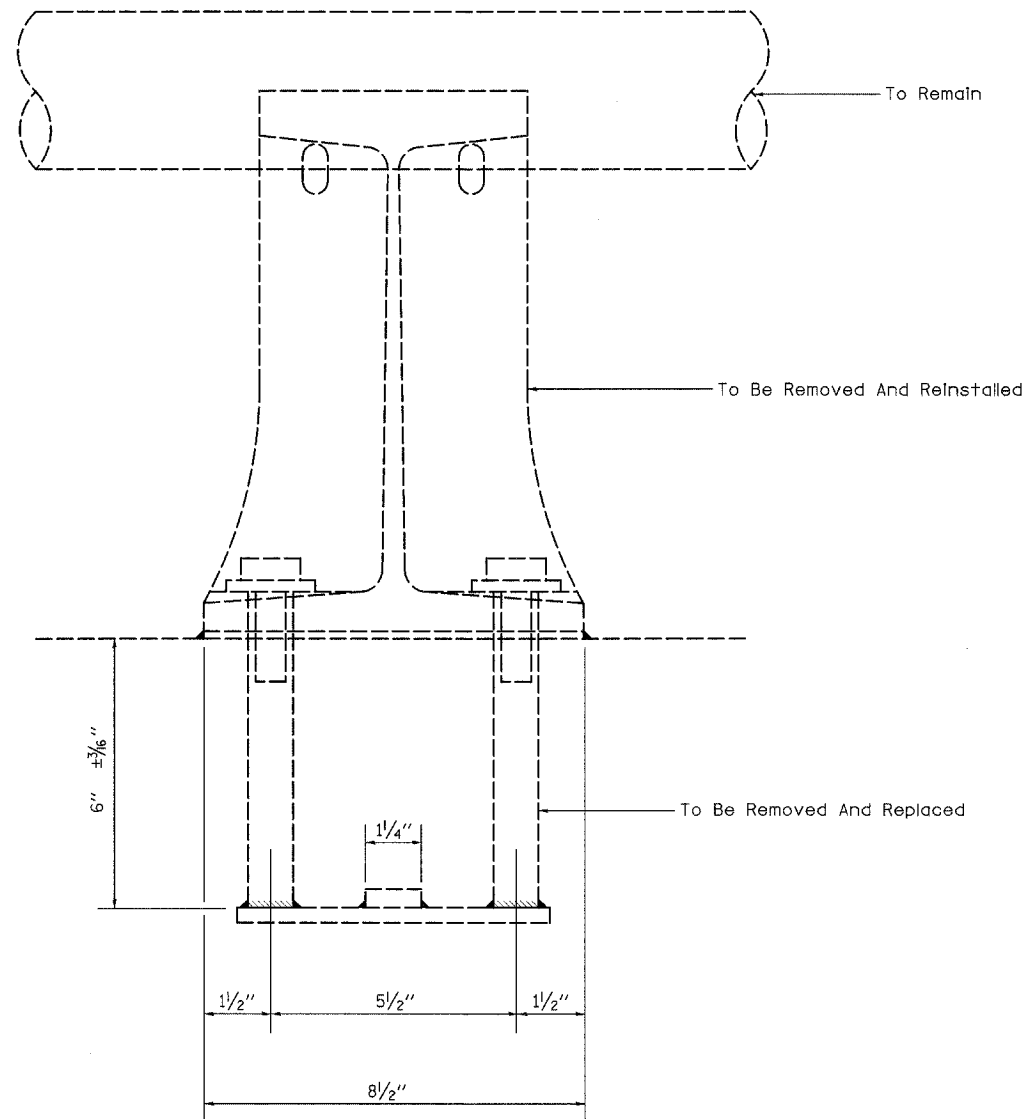

2 - 1/2" ϕ x 1 3/4" hex. hd. cap screws
Std. flat washers. (stnl. stl.)

1/8" Fabric Bearing Pad

2 - 3/4" ϕ welded studs drilled
and tapped for 1/2"-13. AASHTO
M 169 (1015, 1018, 1020)

3/8" x 1 1/4" x 7"

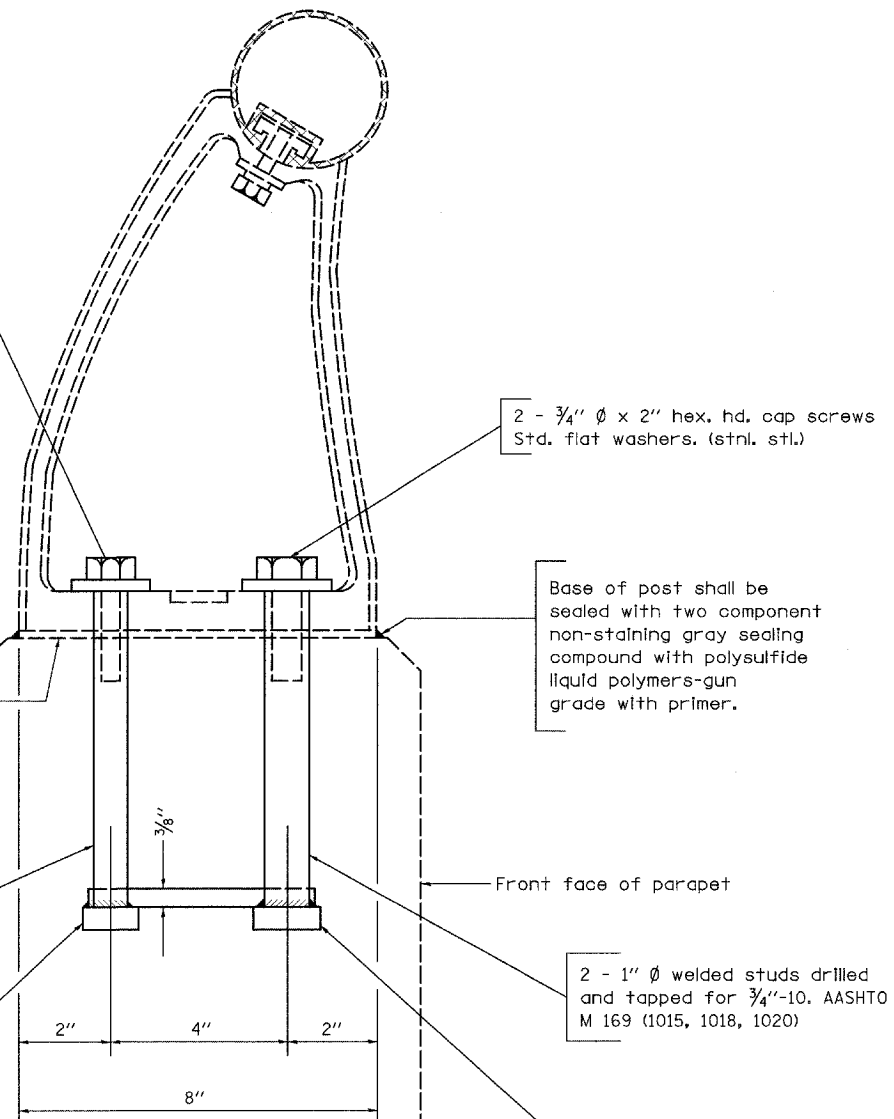

2 - 3/4" ϕ x 2" hex. hd. cap screws
Std. flat washers. (stnl. stl.)

Base of post shall be
sealed with two component
non-staining gray sealing
compound with polysulfide
liquid polymers-gun
grade with primer.

Front face of parapet

2 - 1" ϕ welded studs drilled
and tapped for 3/4"-10. AASHTO
M 169 (1015, 1018, 1020)

1/2" x 1 1/2" x 7"

Note: Post anchorage supports are to be removed and replaced during construction. new bolts, shim plates, and post support anchor assemblies are to be provided.

FILE NAME = c:\projects\74171d\karenbr\edge.dgn	USER NAME = swartzw	DESIGNED -	REVISED -
		DRAWN -	REVISED -
	PLOT SCALE = 20.0000 "/ IN.	CHECKED -	REVISED -
	PLOT DATE = 3/20/2008	DATE -	REVISED -

STATE OF ILLINOIS
DEPARTMENT OF TRANSPORTATION

RAIL SUPPORT ANCHOR DETAILS

SCALE: N/A SHEET NO. 49 OF 52 SHEETS STA. TO STA.

F.A.I. RTE.	SECTION	COUNTY	TOTAL SHEETS	SHEET NO.
72	(58,74X66,67)RS-1	MACON	88	7
CONTRACT NO. 741				
FED. ROAD DIST. NO. ILLINOIS FED. AID PROJECT				

SHEET NO.
52 SHEETS

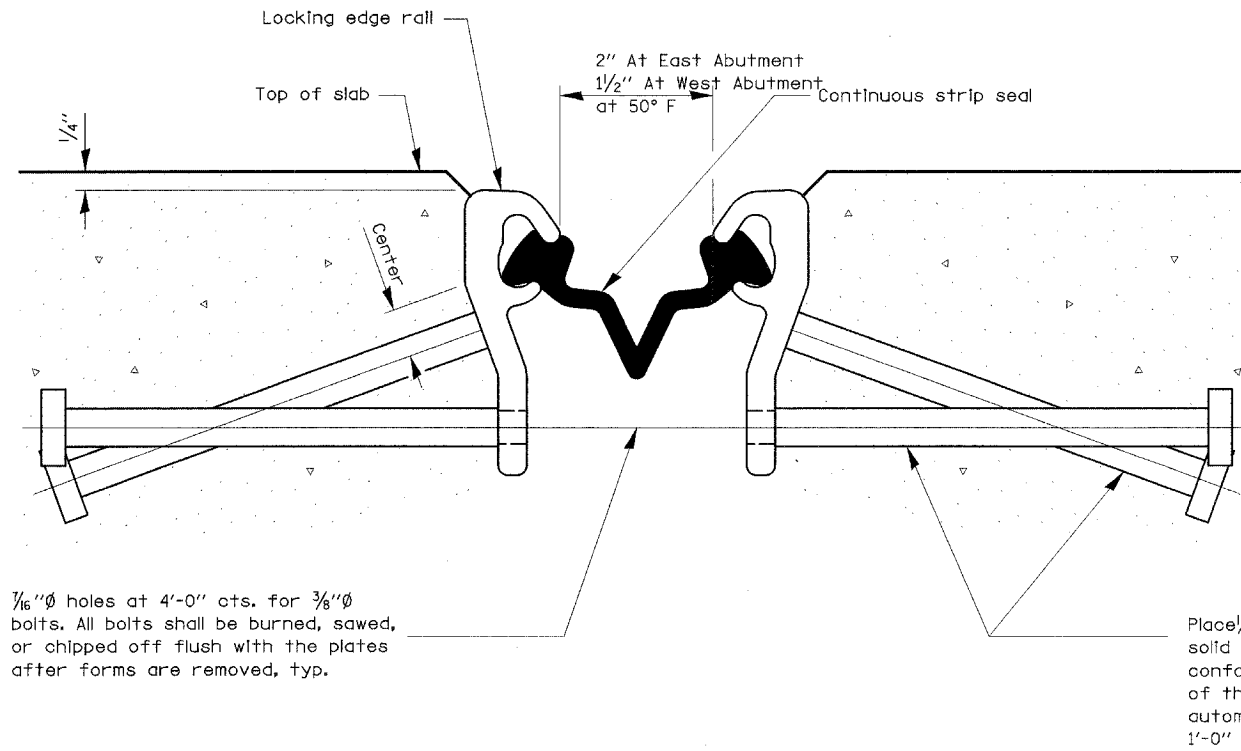

1/16"Ø holes at 4'-0" cts. for 3/8"Ø bolts. All bolts shall be burned, sawed, or chipped off flush with the plates after forms are removed, typ.

Place 1/2" ± x 6" granular or solid flux filled headed studs conforming to Article 1006.32 of the Std. Specs., automatically end welded at 1'-0" alt. cts.

SECTION THRU STRIP SEAL JOINT

Notes:

The strip seal shall be made continuous and shall have a minimum thickness of 1/4". The configuration of the strip seal shall match the configuration of the Locking Edge Rails.

The height and thickness of the Locking Edge Rails shown are minimum dimensions. The actual configuration of the Locking Edge Rails and matching strip seal may vary from manufacturer to manufacturer. Flanged edge rails will not be allowed.

The inside of the Locking Edge Rail groove shall be free of weld residue.

Locking Edge Rails may be spliced at slope discontinuities and stage construction joints.

The manufacturer's recommended installation methods shall be followed.

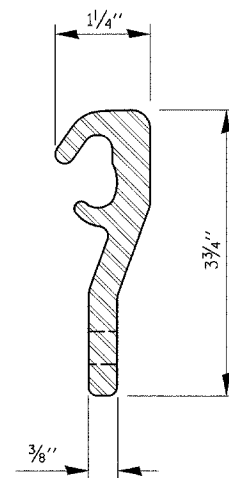

LOCKING EDGE RAIL

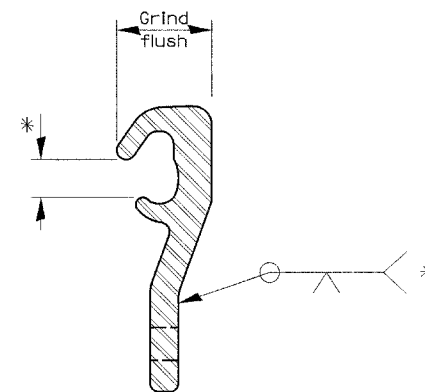

LOCKING EDGE RAIL SPLICE

• Omit weld at seal opening.

BILL OF MATERIAL

SN	Item	Unit	Total
058-0093	Preformed Joint Strip Seal	Foot	96'
058-0094	Preformed Joint Strip Seal	Foot	96'

FILE NAME = c:\projects\74171d\karen\ridge.dgn	USER NAME = swartzrk	DESIGNED -	REVISED -
		DRAWN -	REVISED -
	PLOT SCALE = 20,0000' / IN.	CHECKED -	REVISED -
	PLOT DATE = 3/20/2008	DATE -	REVISED -

**STATE OF ILLINOIS
DEPARTMENT OF TRANSPORTATION**

**PREFORMED JOINT STRIP SEAL
058-0093 (EB) & 058-0094 (WB)**

SCALE: N/A SHEET NO. 50 OF 52 SHEETS STA. TO STA.

F.A.I. RTE. 72	SECTION (58,74X66,67)RS-1	COUNTY MACON	TOTAL SHEETS 88	SHEET NO. 75
FED. ROAD DIST. NO.			ILLINOIS FED. AID PROJECT	
CONTRACT NO. 741				

SHEET NO.
52 SHEET

* Granular or solid flux filled headed studs conforming to Article 1006.32 of the Std. Specs., automatically end welded.

** When joint is fixed, dimension is set at 1 1/2".

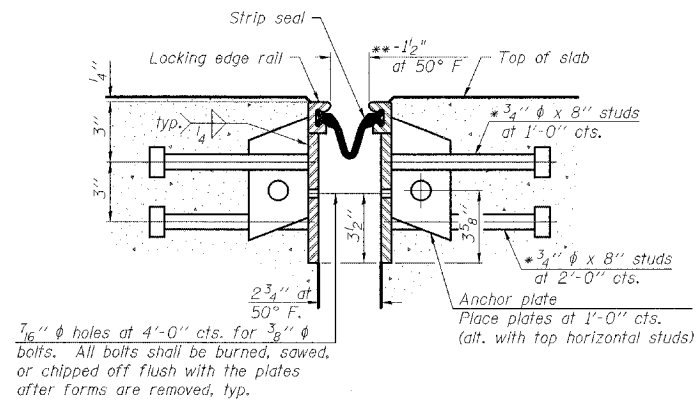
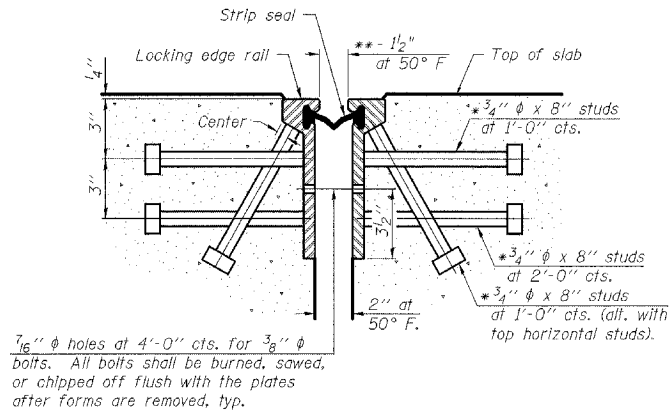

Notes:

The strip seal shall be made continuous and shall have a minimum thickness of 1/4". The configuration of the strip seal shall match the configuration of the Locking Edge Rails. Open or "webbed" strip seal gland configurations are not permitted. The gland shall be sized for a maximum rated movement of 4 inches. The height and thickness of the Locking Edge Rails shown are minimum dimensions. The actual configuration of the Locking Edge Rails and matching strip seal may vary from manufacturer to manufacturer. Flanged edge rails will not be allowed. Locking Edge Rails may be spliced at slope discontinuities and stage construction joints. The manufacturer's recommended installation methods shall be followed. The joint opening and deck dimensions detailed on the superstructure are based on a rolled rail expansion joint. If the Contractor elects to use the welded rail expansion joint, the opening and deck dimensions shall be modified according to the dimensions detailed on this sheet. Required modifications shall be made at no additional cost to the State. All steel components shall be galvanized after fabrication according to Article 520.03 of the Standard Specifications.

SECTION THRU ROLLED RAIL JOINT

SECTION THRU WELDED RAIL JOINT

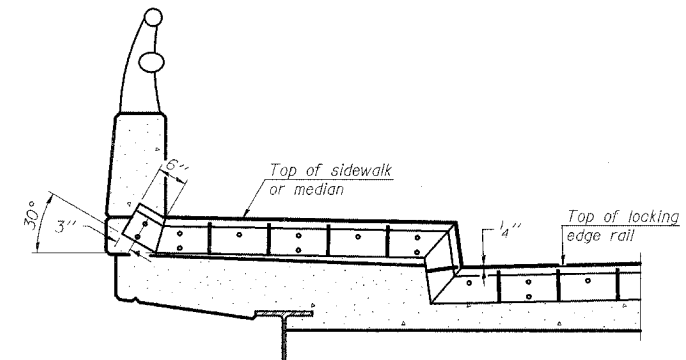
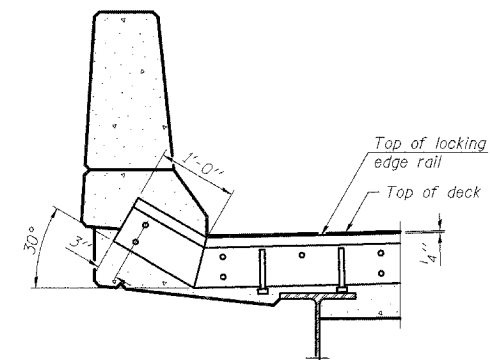
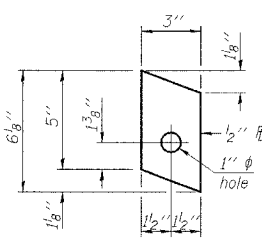
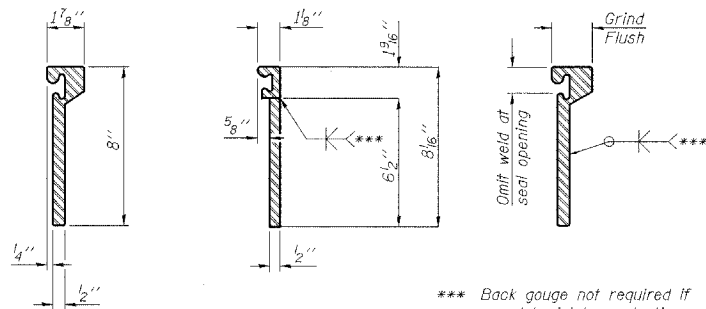

AT PARAPET

AT SIDEWALK OR MEDIAN

ROLLED (EXTRUDED) RAIL

WELDED RAIL

LOCKING EDGE RAIL SPLICE

The inside of the locking edge rail groove shall be free of weld residue.

LOCKING EDGE RAILS

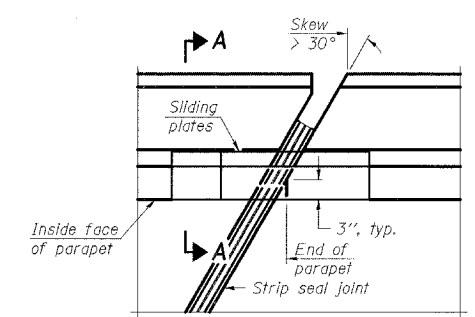

PLAN

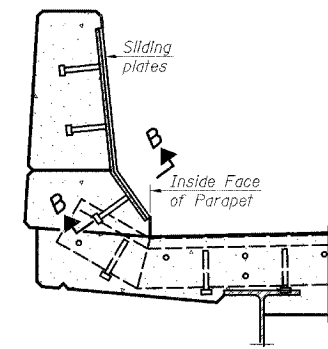

SECTION A-A

TYPICAL END TREATMENTS

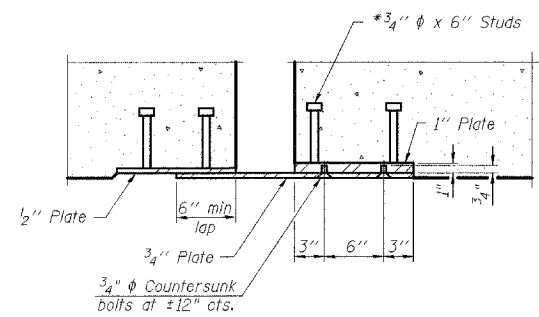

SECTION B-B

BILL OF MATERIAL

SN	Item	Unit	Total
058-0095	Preformed Joint Strip Seal	Foot	192'
058-0096	Preformed Joint Strip Seal	Foot	192'
058-0097	Preformed Joint Strip Seal	Foot	82'

PREFORMED JOINT STRIP SEAL

POINT BLOCK DETAILS (for skews > 30°)

EJ-SSJ 11-1-06

The diameter of this part is the same as the diameter of the bar spliced.

The diameter of this part is equal or larger than the diameter of bar spliced.

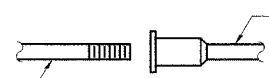

ROLLED THREAD DOWEL BAR



**** ONE PIECE**

Wire Connector

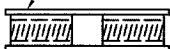

WELDED SECTIONS

BAR SPLICER ASSEMBLY ALTERNATIVES

** Heavy Hex Nuts conforming to ASTM A 563, Grade C, D or DH may be used.

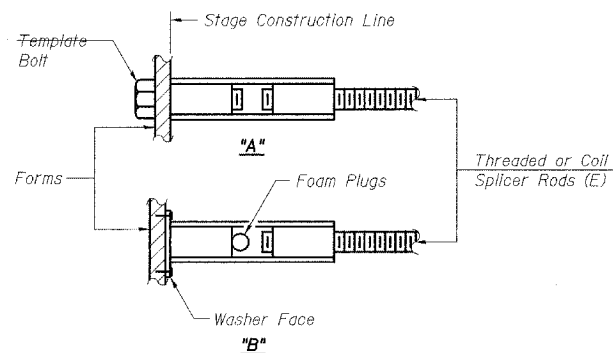

INSTALLATION AND SETTING METHODS

"A" : Set bar splicer assembly by means of a template bolt.
 "B" : Set bar splicer assembly by nailing to wood forms or cementing to steel forms.
 (E) : Indicates epoxy coating.

NOTES

Bar splicer assemblies shall be of an approved type and shall develop in tension at least 125 percent of the yield strength of the lapped reinforcement bars.

Splicer rods shall be of minimum 60 ksi yield strength, threaded or coiled full length. All reinforcement bars shall be lapped and tied to the splicer rods or dowel bars.

Bar splicer assemblies shall be epoxy coated according to the requirements for reinforcement bars.

Other systems of similar design may be submitted to the Engineer for approval. Approval shall be based on certified test results from an approved testing laboratory that the proposed bar splicer assembly satisfies the following requirements:

- ① Minimum Capacity = $1.25 \times f_y \times A_t$
(Tension in kips)
- ② Minimum *Pull-out Strength = $0.66 \times f_y \times A_t$
(Tension in kips)

Where f_y = Yield strength of lapped reinforcement bars in ksi.
 A_t = Tensile stress area of lapped reinforcement bars.
 * = 28 day concrete

BAR SPLICER ASSEMBLIES			
Bar Size to be Spliced	Splicer Rod or Dowel Bar Length	Strength Requirements	
		Min. Capacity kips - tension	Min. Pull-Out Strength kips - tension
#4	1'-8"	14.7	7.9
#5	2'-0"	23.0	12.3
#6	2'-7"	33.1	17.4
#7	3'-5"	45.1	23.8
#8	4'-6"	58.9	31.3
#9	5'-9"	75.0	39.6
#10	7'-3"	95.0	50.3
#11	9'-0"	117.4	61.8

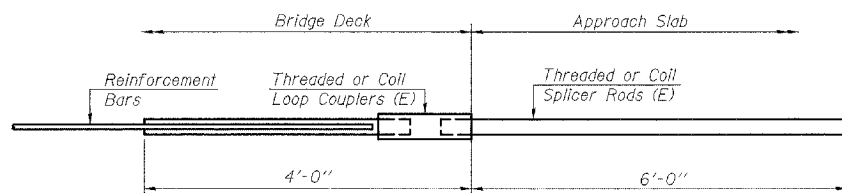

FOR INTEGRAL OR SEMI-INTEGRAL ABUTMENTS

Bar Splicer for #5 bar		
Min. Capacity =	23.0 kips - tension	
Min. Pull-out Strength =	12.3 kips - tension	
No. Required =		

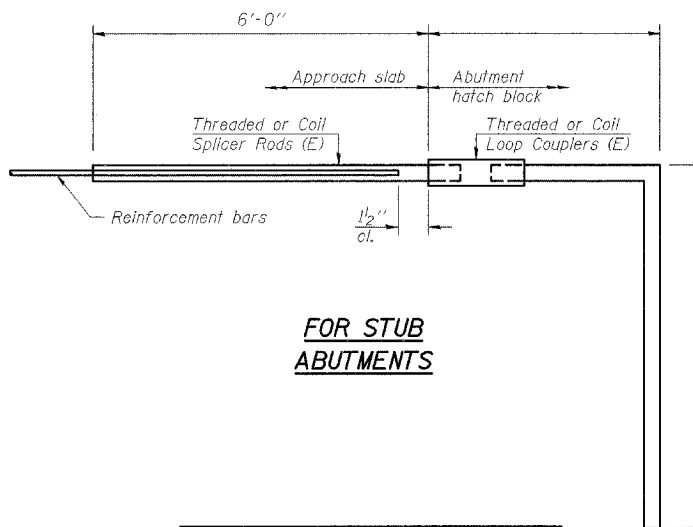

FOR STUB ABUTMENTS

Bar Splicer for #5 bar		
Min. Capacity =	23.0 kips - tension	
Min. Pull-out Strength =	12.3 kips - tension	
No. Required =		

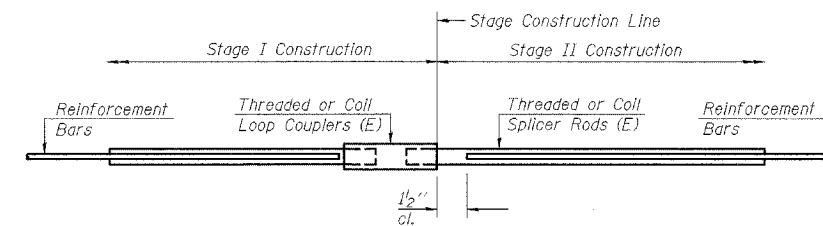

STANDARD

Bar Size	No. Assemblies Required	Location
#5	24	058-0093
#6	4	058-0093
#5	24	058-0094
#6	4	058-0094
#5	96	058-0095
#6	4	058-0095
#5	96	058-0096
#6	4	058-0096
#5	16	058-0097
#6	4	058-0097

BSD-1

11-1-06

BAR SPLICER ASSEMBLY DETAILS

FILE NAME = c:\projects\74171d\karenbridge.dgn	USER NAME = swartzrk	DESIGNED -	REVISED -
		DRAWN -	REVISED -
	PLOT SCALE = 20,0000 ' / IN.	CHECKED -	REVISED -
	PLOT DATE = 3/20/2008	DATE -	REVISED -

**STATE OF ILLINOIS
DEPARTMENT OF TRANSPORTATION**

BAR SPLICER ASSEMBLY DETAILS

SCALE: SHEET NO. 52 OF 52 SHEETS STA. TO STA.

F.A.I. RTE.	SECTION	COUNTY	TOTAL SHEETS	SH N
72	(58,74X66,67)RS-1	MACON	88	7
CONTRACT NO. 741			FED. ROAD DIST. NO. ILLINOIS FED. AID PROJECT	

SHEET NO. 52 SHEETS

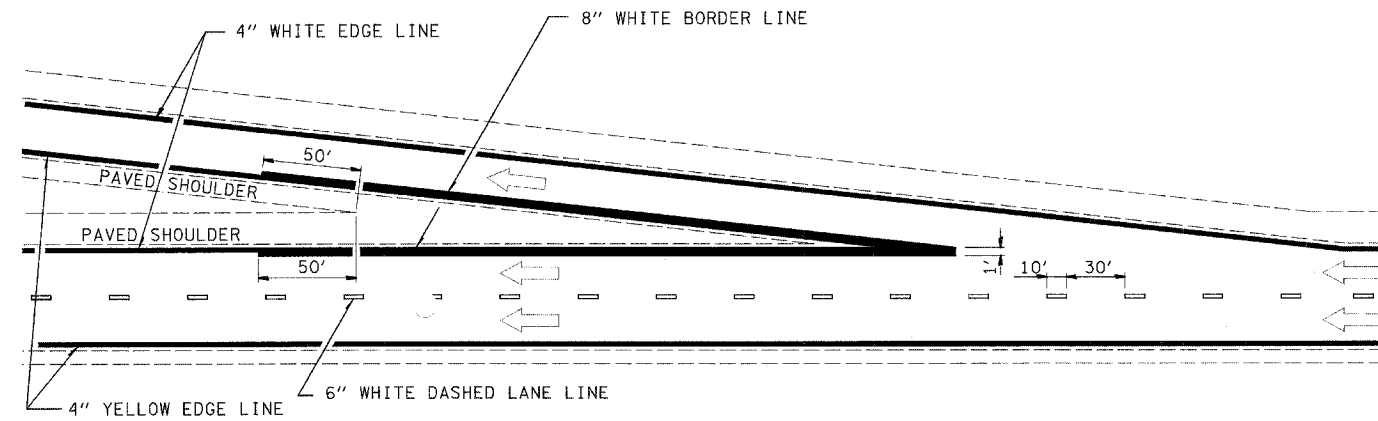

TYPICAL EXIT RAMP MARKING

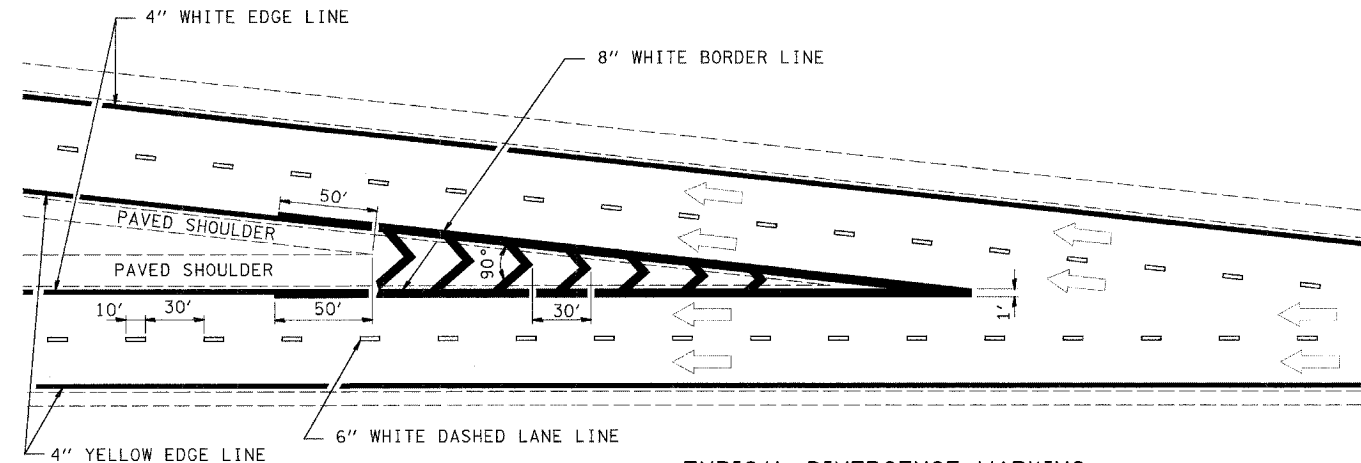

TYPICAL DIVERGENCE MARKING

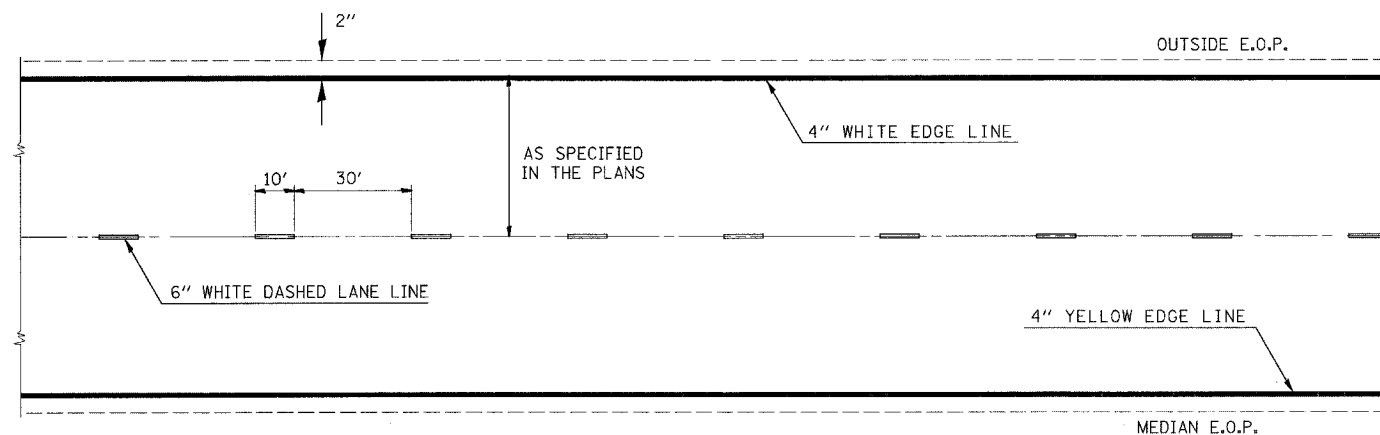

TYPICAL CENTERLINE & EDGELINE MARKINGS

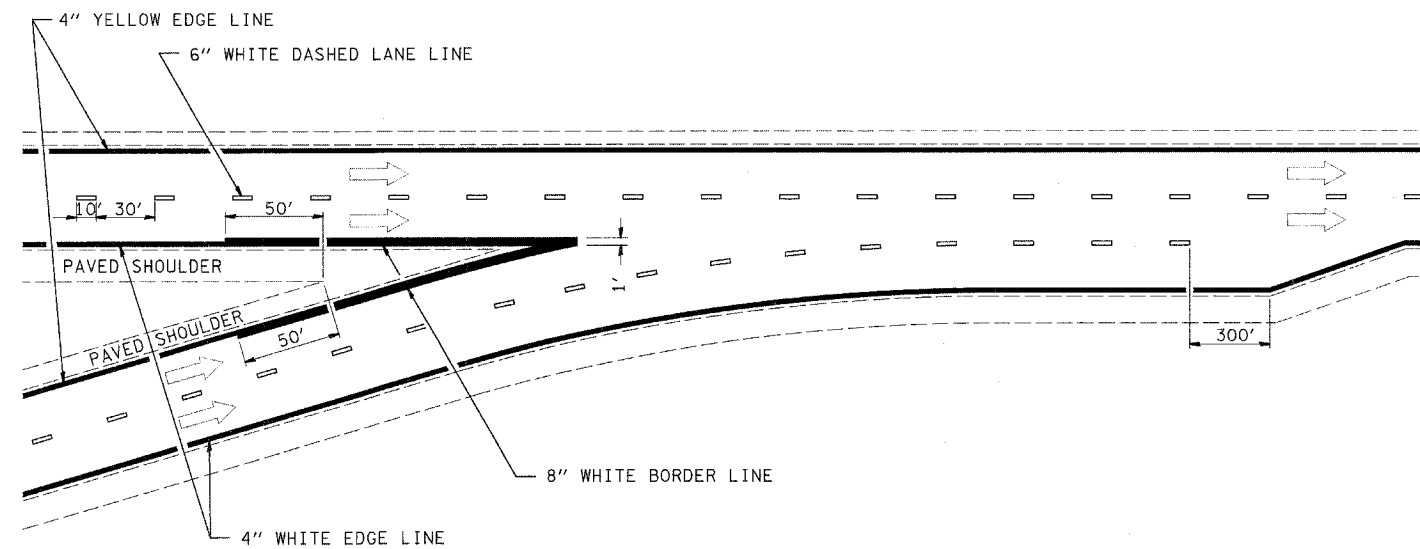

TYPICAL CONVERGENCE MARKING

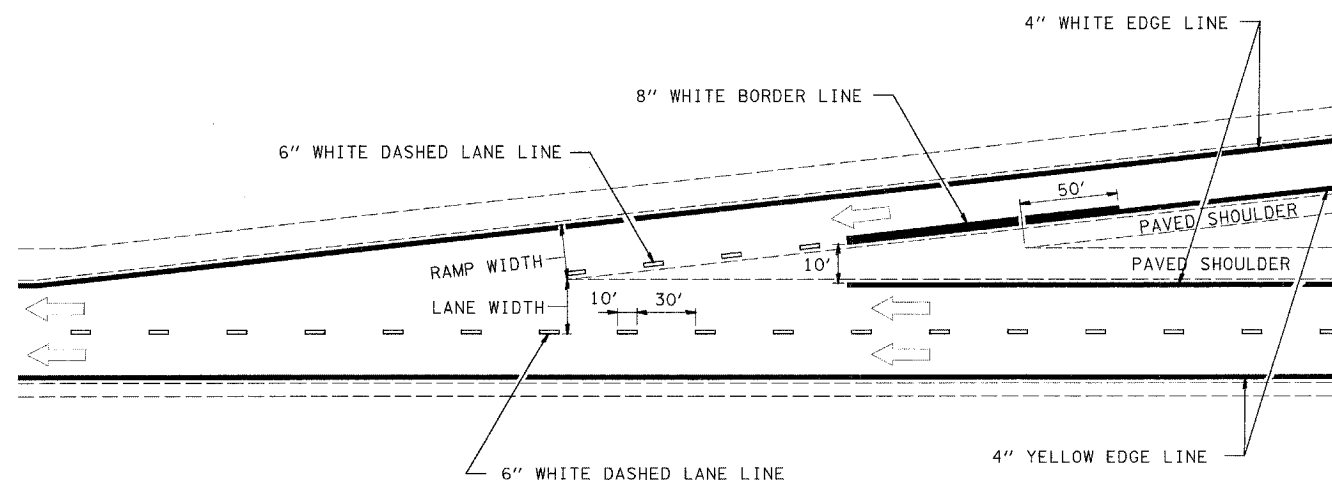

TYPICAL ENTRANCE RAMP MARKING

TYPICAL APPLICATIONS OF INTERCHANGE PAVEMENT MARKING
NOT TO SCALE

REVISIONS	
NAME	DATE
MMO	12-9
DRM	08-C

**BUTT JOINT DETAIL FOR
REST AREA RAMPS**

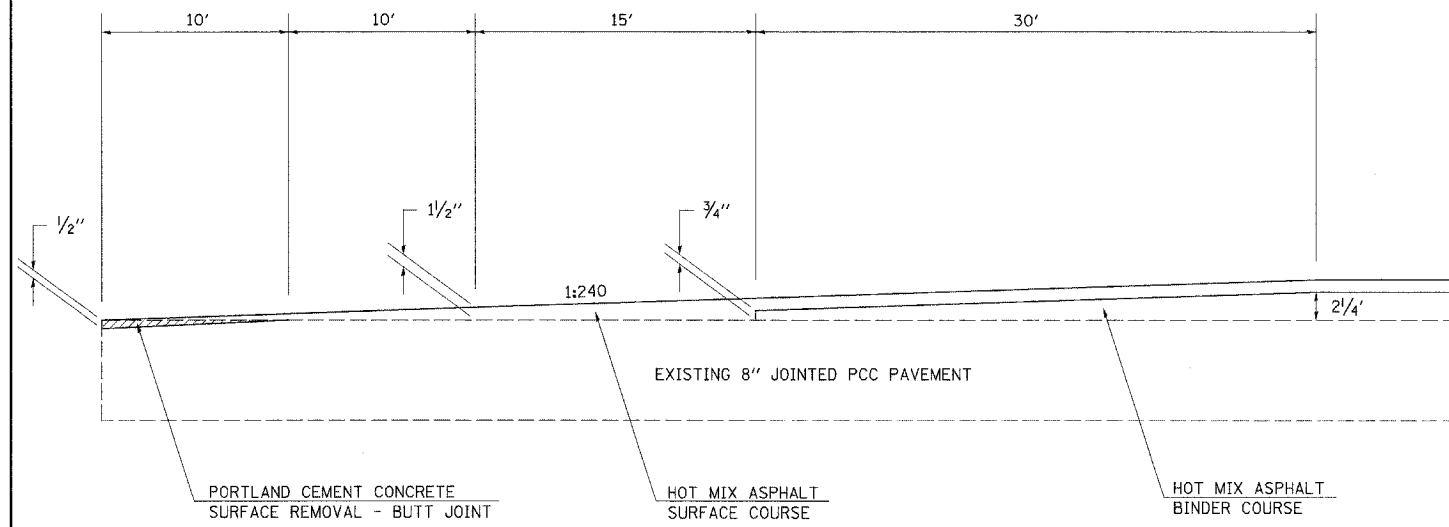

**BUTT JOINT DETAIL
STA. 700+98 & STA. 910+00**

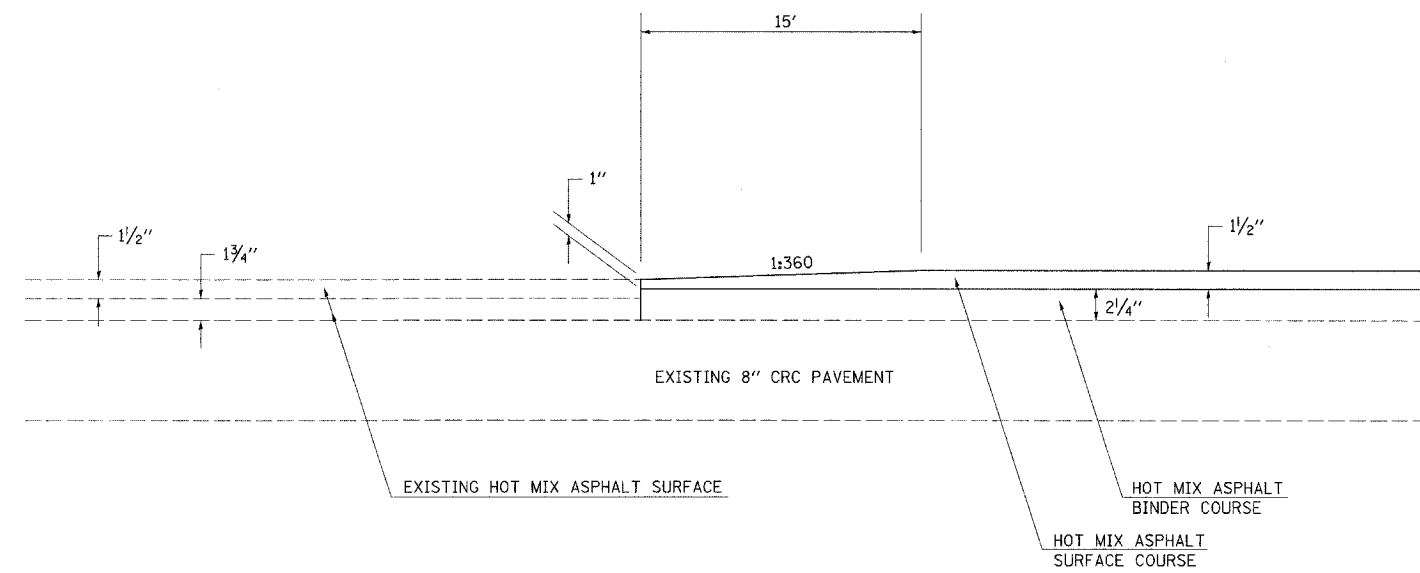

**BUTT JOINT DETAIL
S.N. 058-0093 & 058-0094**

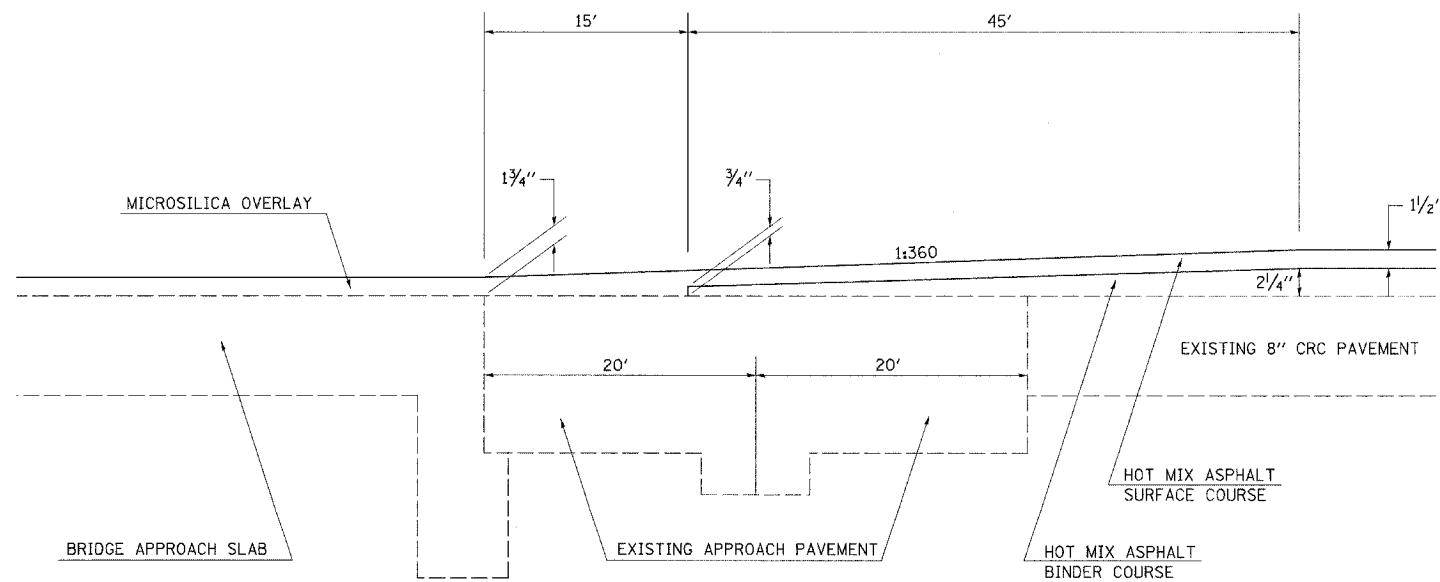

**BUTT JOINT DETAIL
S.N. 058-0095 (EAST APPROACH)**

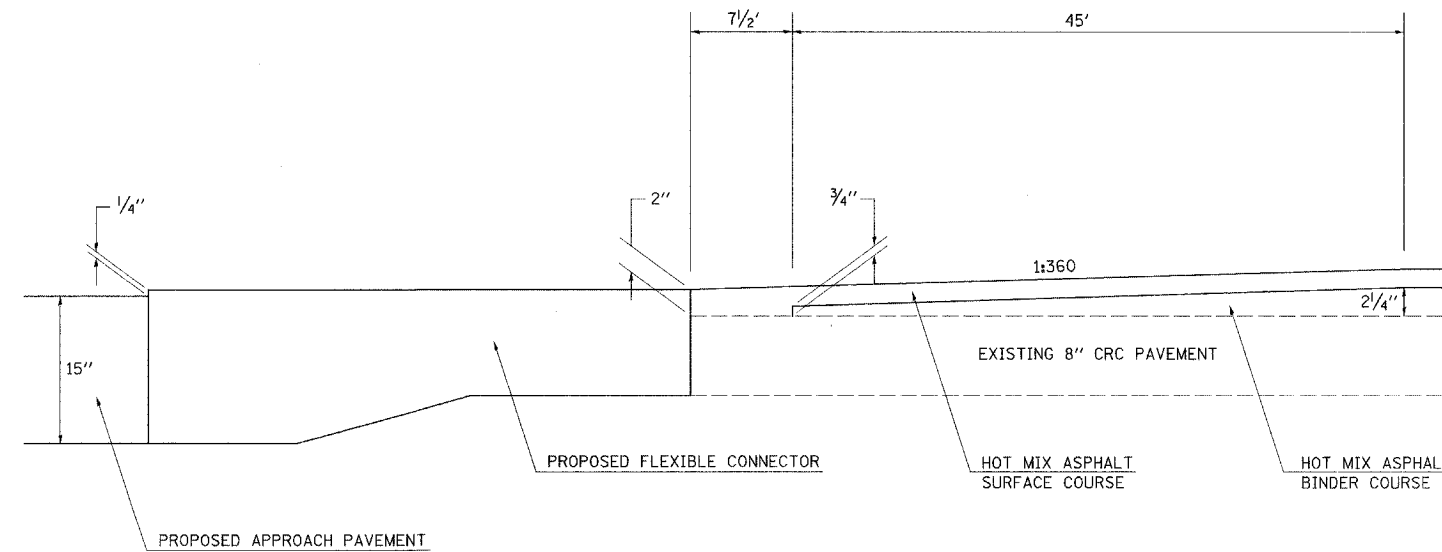

FILE NAME = c:\projects\74171\d\h\details\74171.dgn	USER NAME = swartzk	DESIGNED -	REVISED -
		DRAWN -	REVISED -
	PLOT SCALE = 20,0000' / IN.	CHECKED -	REVISED -
	PLOT DATE = 3/20/2009	DATE -	REVISED -

**STATE OF ILLINOIS
DEPARTMENT OF TRANSPORTATION**

DETAILS

SCALE: NA SHEET NO. OF SHEETS STA. TO STA.

F.A.I. RTE. 72	SECTION (58,74)(66,67)RS-1	COUNTY MACON	TOTAL SHEETS 88	SH N 7
FED. ROAD DIST. NO. ILLINOIS FED. AID PROJECT				CONTRACT NO. 741

BUTT JOINT DETAIL
S.N. 058-0096 (EAST APPROACH)

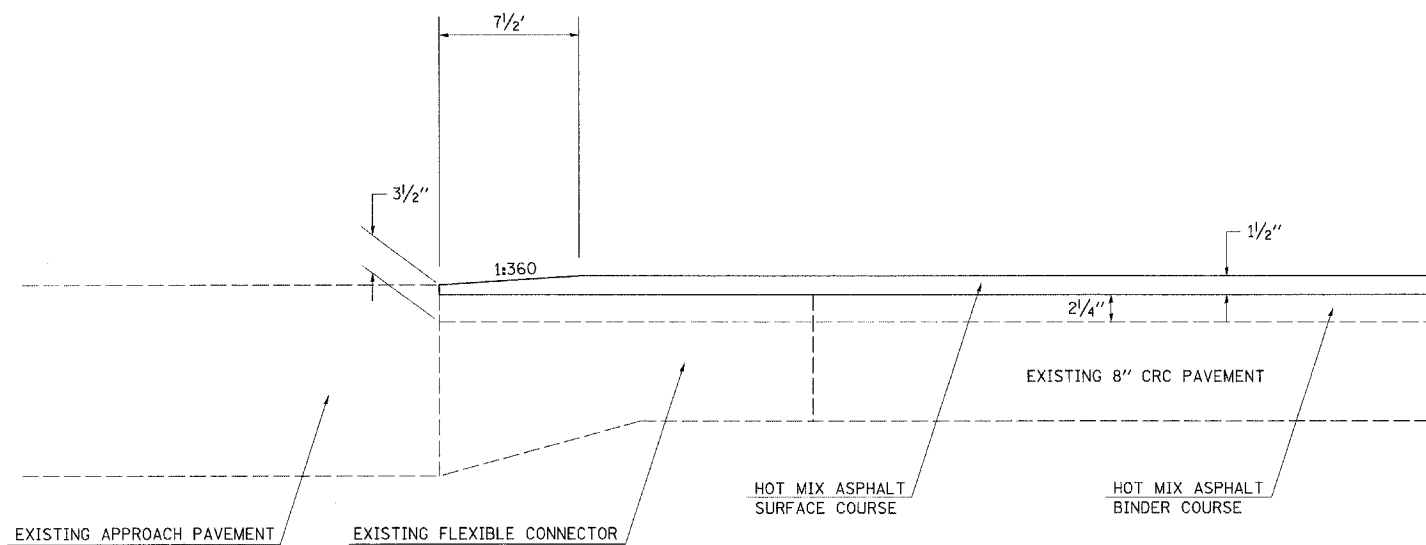

BUTT JOINT DETAIL
S.N. 058-0095 (WEST APPROACH)
S.N. 058-0096 (WEST APPROACH)

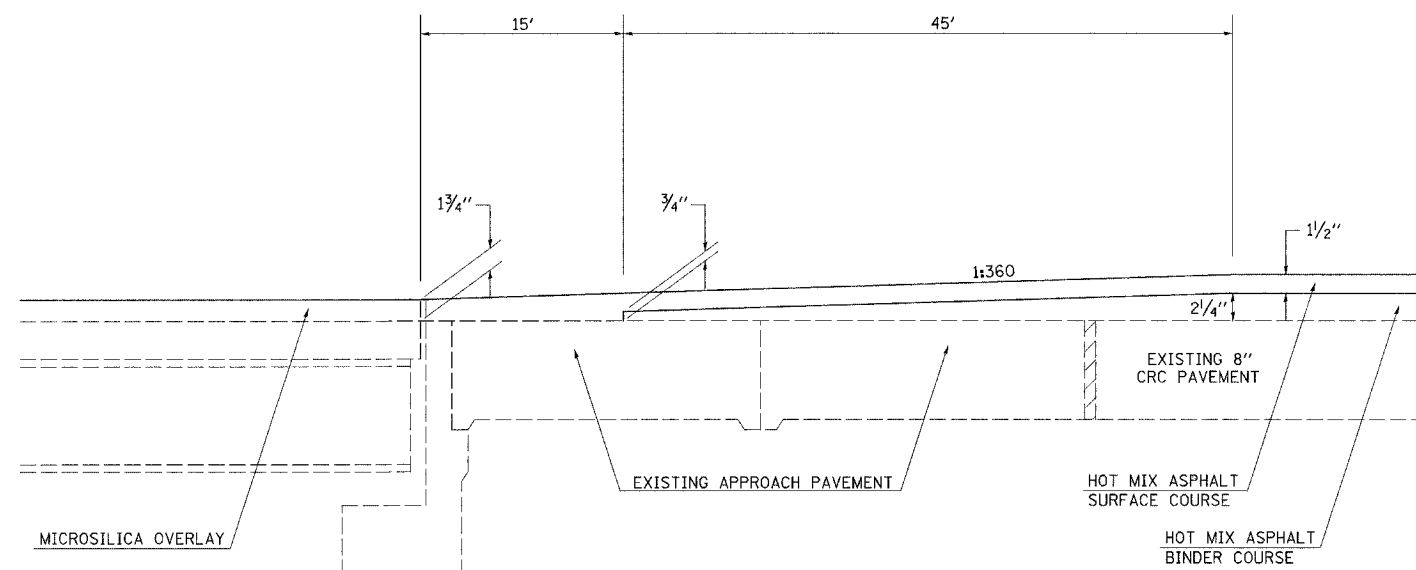

PAVEMENT TRANSITION DETAIL
S.N. 058-0097

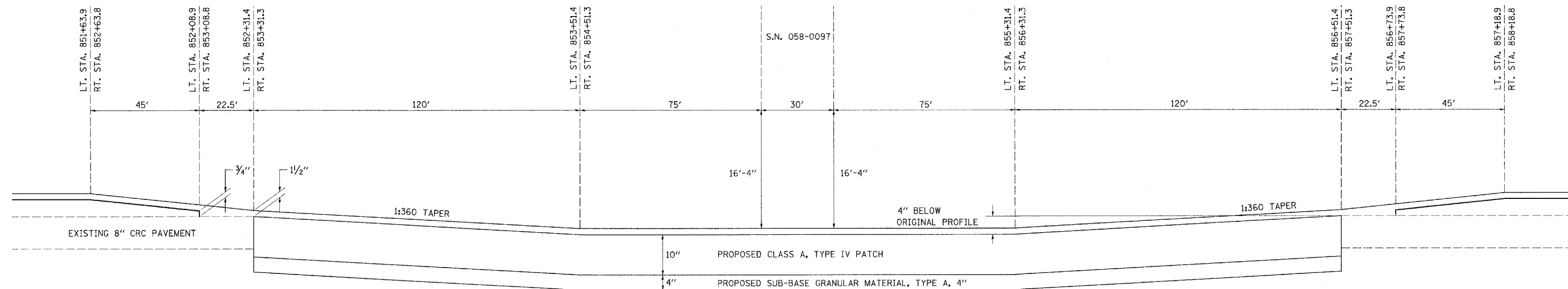

FILE NAME = c:\projects\74171\d\shhtdetails.74171.dgn	USER NAME = swartzw	DESIGNED -	REVISED -
		DRAWN -	REVISED -
	PLOT SCALE = 20,0000' / IN.	CHECKED -	REVISED -
	PLOT DATE = 3/20/2008	DATE -	REVISED -

STATE OF ILLINOIS
DEPARTMENT OF TRANSPORTATION

DETAILS

SCALE: NA SHEET NO. OF SHEETS STA. TO STA.

F.A.I RTE. 72	SECTION (58,74)(66,67)RS-1	COUNTY MACON	TOTAL SHEETS 88	SHE NO 80
FED. ROAD DIST. NO. ILLINOIS FED. AID PROJECT			CONTRACT NO. 741	

BUTT JOINT DETAIL
S.N. 058-0095 (EAST APPROACH)
STAGE I

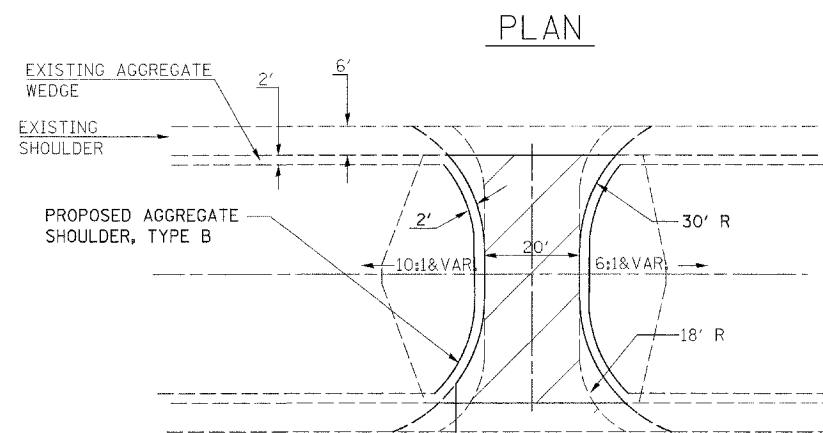
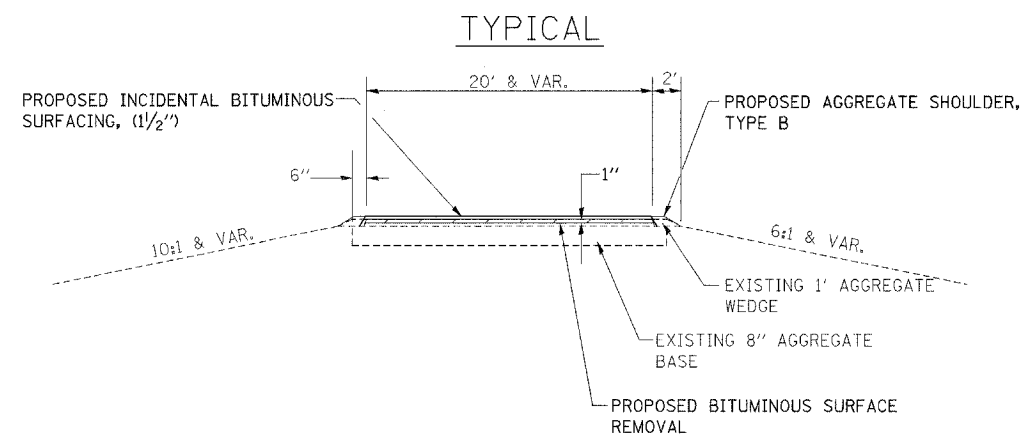
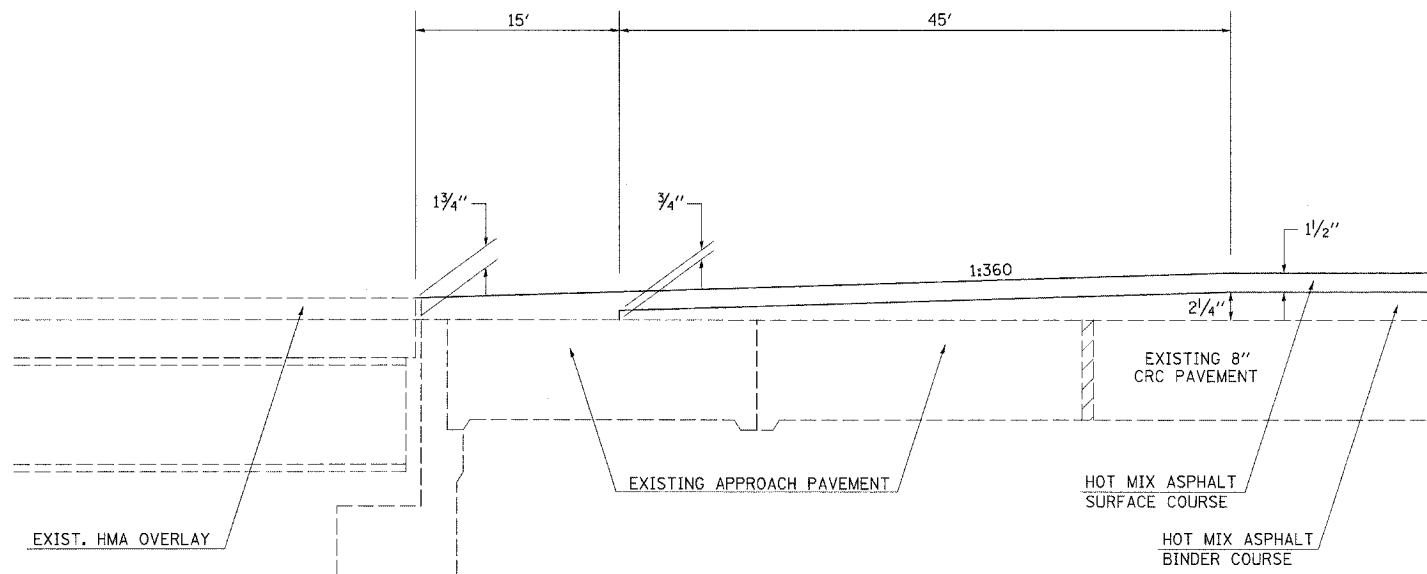

 BITUMINOUS SURFACE REMOVAL, 1"

NOTES

1.) OMIT RUMBLE STRIPS ON SHOULDERS WITHIN THE LIMITS OF THE MEDIAN CROSSOVER.

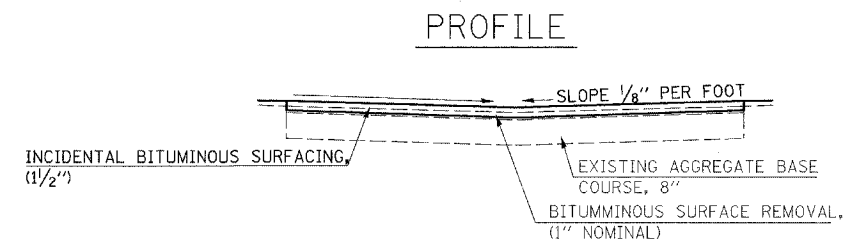

BUTT JOINT DETAIL
S.N. 058-0093, 0094, 0095 (WEST APP)
AND 0096
STAGE I

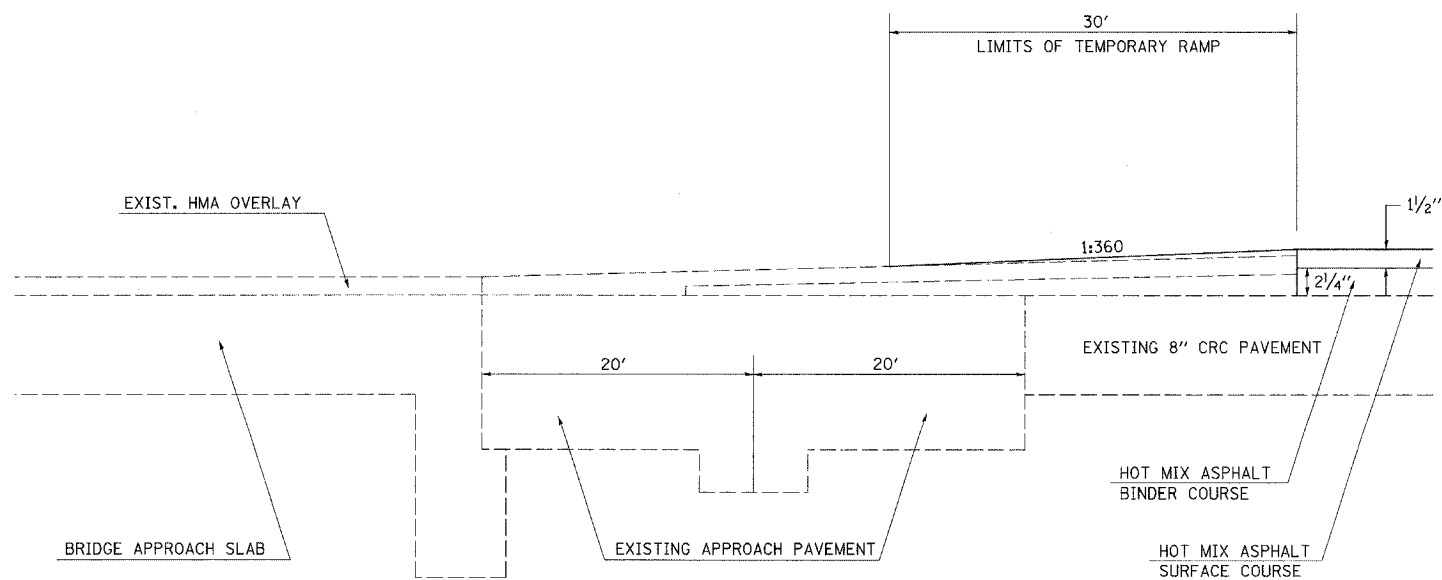

FILE NAME = c:\projects\7417\d\shdetails_74171.dgn	USER NAME = swartzw	DESIGNED -	REVISED -
		DRAWN -	REVISED -
	PLOT SCALE = 20.0000 "/td> <td>CHECKED -</td> <td>REVISED -</td>	CHECKED -	REVISED -
	PLOT DATE = 3/20/2008	DATE -	REVISED -

STATE OF ILLINOIS
DEPARTMENT OF TRANSPORTATION

DETAILS			
SCALE: NA	SHEET NO.	OF SHEETS	STA. TO STA.

F.A.I. RTE.	SECTION	COUNTY	TOTAL SHEETS	SH N
72	(58,74)(66,67)RS-1	MACON	88	8
FED. ROAD DIST. NO.			ILLINOIS FED. AID PROJECT	
			CONTRACT NO. 741	

DETAIL OF FLARED GUARDRAIL AT DUAL STRUCTURES

NOTE: NOT DRAWN TO SCALE

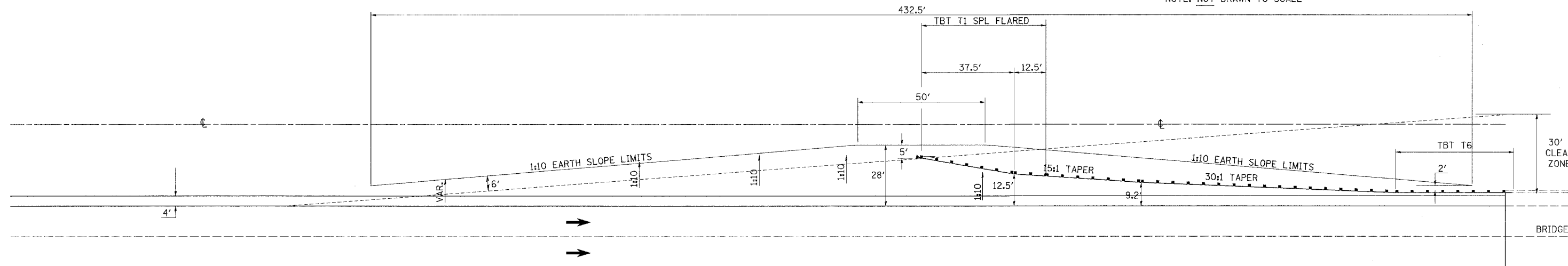

NOTE: SEE PLAN SHEET SCHEDULES FOR LOCATIONS AND STATIONING OF GUARDRAIL.

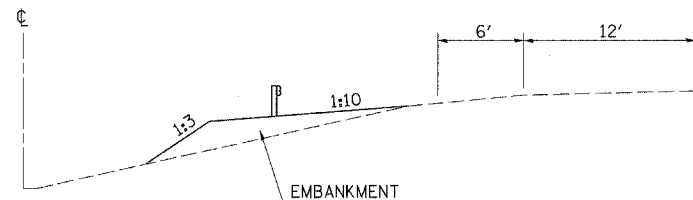

FILE NAME = c:\projects\74171d\shdtdetails.74171.dgn	USER NAME = swartzrw	DESIGNED -	REVISED -
		DRAWN -	REVISED -
	PLOT SCALE = 20,0000' / IN.	CHECKED -	REVISED -
	PLOT DATE = 3/28/2008	DATE -	REVISED -

STATE OF ILLINOIS
DEPARTMENT OF TRANSPORTATION

DETAILS

SCALE: NA SHEET NO. OF SHEETS STA. TO STA.

F.A.I RTE.	SECTION	COUNTY	TOTAL SHEETS	SH N
72	(58,74)(66,67)RS-1	MACON	88	8
CONTRACT NO. 741				
FED. ROAD DIST. NO.		ILLINOIS FED. AID PROJECT		

DATE	
BY	
FINAL SURVEY	
TEMPLATE	
NOTE BOOK	
AREAS CHECKED	
NO.	

DATE	
BY	
ORIGINAL SURVEY	
TEMPLATE	
NOTE BOOK	
AREAS CHECKED	
NO.	

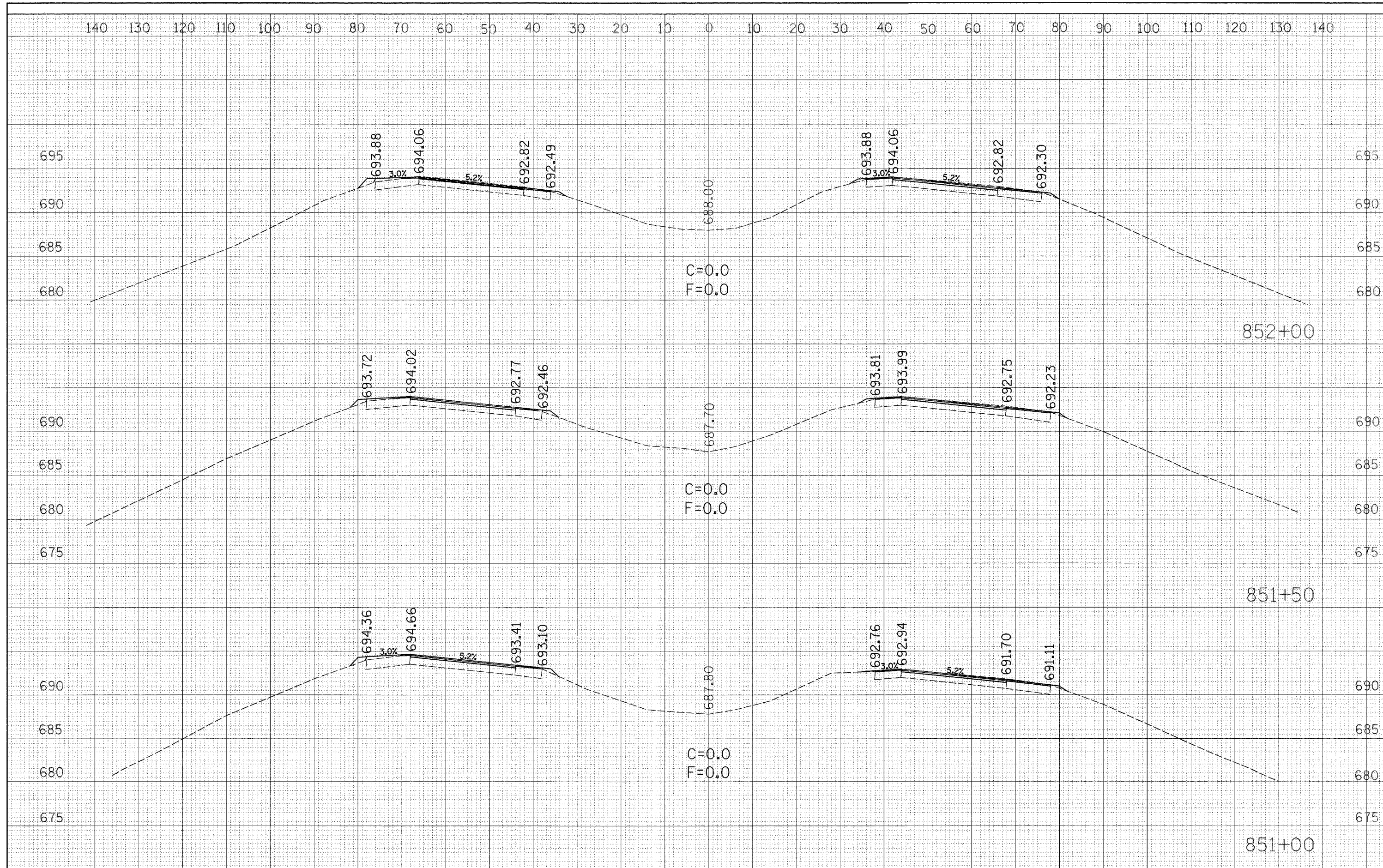

FILE NAME = c:\projects\74171d\sheet_74171.dgn

USER NAME = davisonjl
 PLOT SCALE = 10.0000' / IN.
 PLOT DATE = 3/20/2008

DESIGNED - JLD
 CHECKED -
 DRAWN - JLD
 CHECKED -

REVISED -
 REVISED -
 REVISED -
 REVISED -

**STATE OF ILLINOIS
 DEPARTMENT OF TRANSPORTATION**

PAVEMENT PATCH
 SCALE: 10 SHEET NO. 1 OF 6 SHEETS STA. 851+00 TO STA. 852+00

F.A.I. RTE.	SECTION	COUNTY	TOTAL SHEETS	SHE NO.
72	(58,74)66,67RS-1	MACON	88	8
CONTRACT NO. 741				
FED. ROAD DIST. NO. ILLINOIS FED. AID PROJECT				

FINAL SURVEY	SURVEYED	BY	DATE
SURVEY	PLOTTED		
NOTE BOOK	TEMPLATE		
NO.	AREAS CHECKED		

ORIGINAL SURVEY	SURVEYED	BY	DATE
SURVEY	PLOTTED		
NOTE BOOK	TEMPLATE		
NO.	AREAS CHECKED		

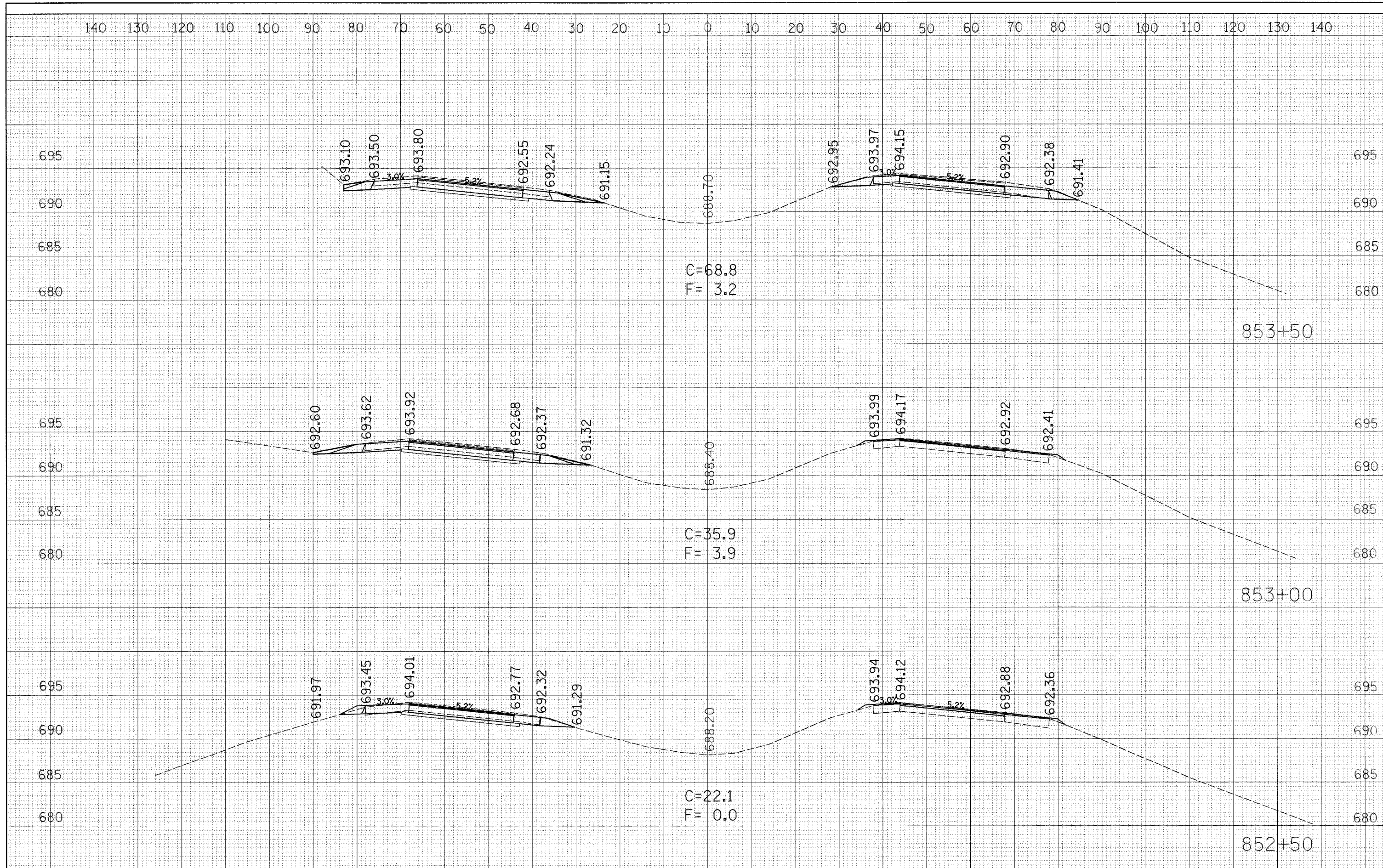

FILE NAME = e:\projects\74171d\sheet.74171.dgn

USER NAME = devisorjl

PLOT SCALE = 10.0000' / IN.
 PLOT DATE = 3/20/2008

DESIGNED - JLD
 CHECKED -
 DRAWN - JLD
 CHECKED -

REVISED -
 REVISED -
 REVISED -
 REVISED -

**STATE OF ILLINOIS
 DEPARTMENT OF TRANSPORTATION**

PAVEMENT PATCH

SCALE: 10 SHEET NO. 2 OF 6 SHEETS STA. 852+50 TO STA. 853+50

F.A. RTE.	SECTION	COUNTY	TOTAL SHEETS	SH. N.
72	(58,74)(66,67)RS-1	MACON	88	E
CONTRACT NO. 741				
FED. ROAD DIST. NO. ILLINOIS FED. AID PROJECT				

FINAL SURVEY	DATE
BY	
SURVEYED	
NOTE BOOK	
AREAS CHECKED	

ORIGINAL SURVEY	DATE
BY	
SURVEYED	
NOTE BOOK	
AREAS CHECKED	

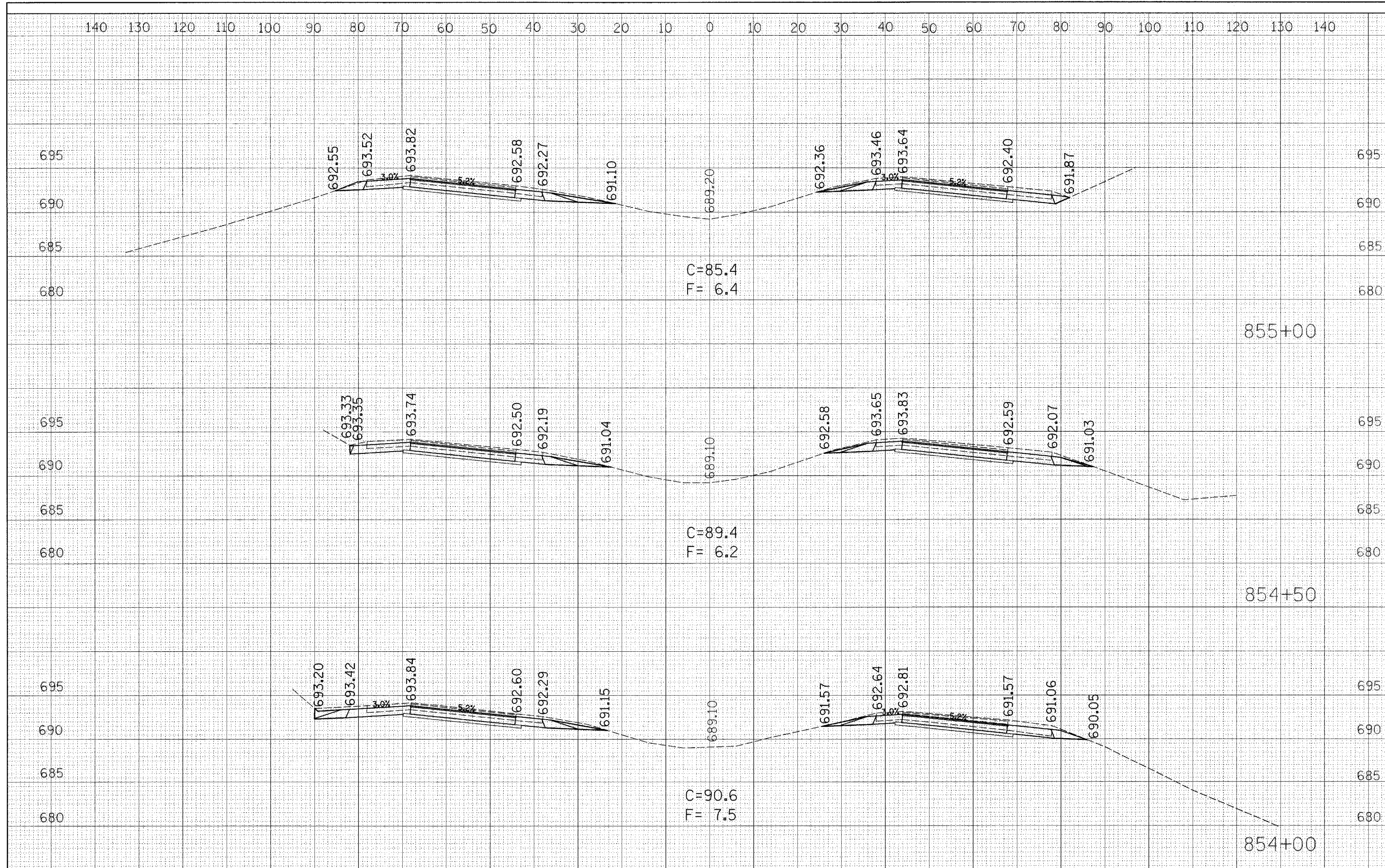

FILE NAME =
 c:\projects\74171d\sheet_74171.dgn

USER NAME = davisonjl
 PLOT SCALE = 10.0000' / IN.
 PLOT DATE = 3/20/2008

DESIGNED - JLD
 CHECKED -
 DRAWN - JLD
 CHECKED -

REVISED -
 REVISED -
 REVISED -
 REVISED -

**STATE OF ILLINOIS
 DEPARTMENT OF TRANSPORTATION**

PAVEMENT PATCH
 SCALE: 10 SHEET NO. 3 OF 6 SHEETS STA. 854+00 TO STA. 855+00

F.A. RTE. 72	SECTION (58,74)(66,67)RS-1	COUNTY MACON	TOTAL SHEETS 88	SHE NO. 85
FED. ROAD DIST. NO.		ILLINOIS FED. AID PROJECT		
CONTRACT NO. 741				

FINAL SURVEY NO.	SURVEYED	BY	DATE
	PLOTTED		
	TEMPLATE		
	NOTE BOOK		
	AREAS CHECKED		

ORIGINAL SURVEY NO.	SURVEYED	BY	DATE
	PLOTTED		
	TEMPLATE		
	NOTE BOOK		
	AREAS CHECKED		

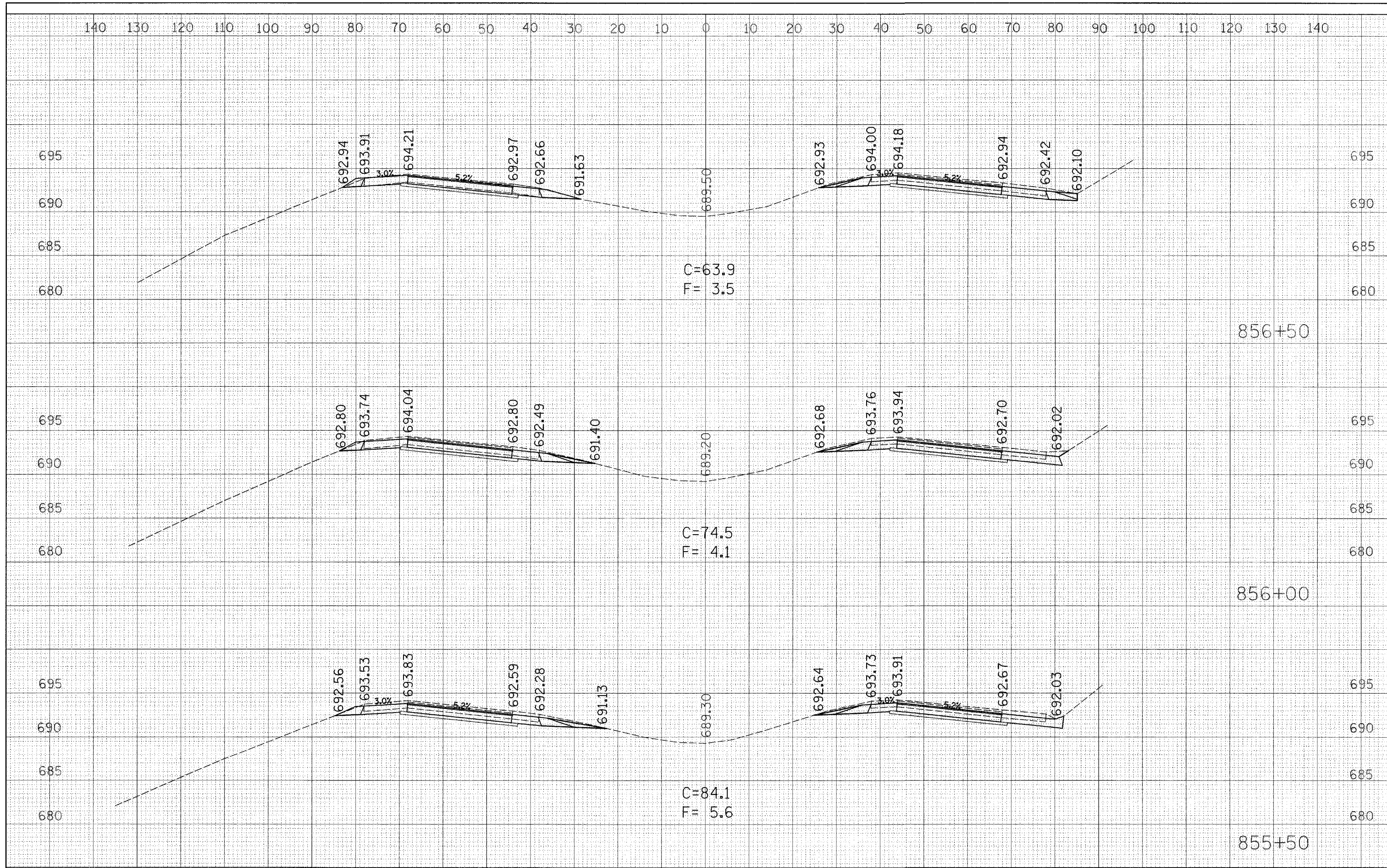

FILE NAME =
c:\projects\74171d\sheet_74171.dgn

USER NAME = davissonjl
PLOT SCALE = 10,0000' / IN.
PLOT DATE = 3/28/2008

DESIGNED - JLD
CHECKED -
DRAWN - JLD
CHECKED -

REVISED -
REVISED -
REVISED -
REVISED -

**STATE OF ILLINOIS
DEPARTMENT OF TRANSPORTATION**

PAVEMENT PATCH

SCALE: 10 SHEET NO. 4 OF 6 SHEETS STA. 855+50 TO STA. 856+50

F.A. RTE. 72	SECTION (58,74)(66,67)RS-1	COUNTY MACON	TOTAL SHEETS 88	SH. NO. 8
CONTRACT NO. 741				
FED. ROAD DIST. NO. ILLINOIS FED. AID PROJECT				

DATE	
BY	
SURVEYED	
PLOTTED	
TEMPLATE	
AREAS	
CHECKED	
NO.	

DATE	
BY	
SURVEYED	
PLOTTED	
TEMPLATE	
AREAS	
CHECKED	
NO.	

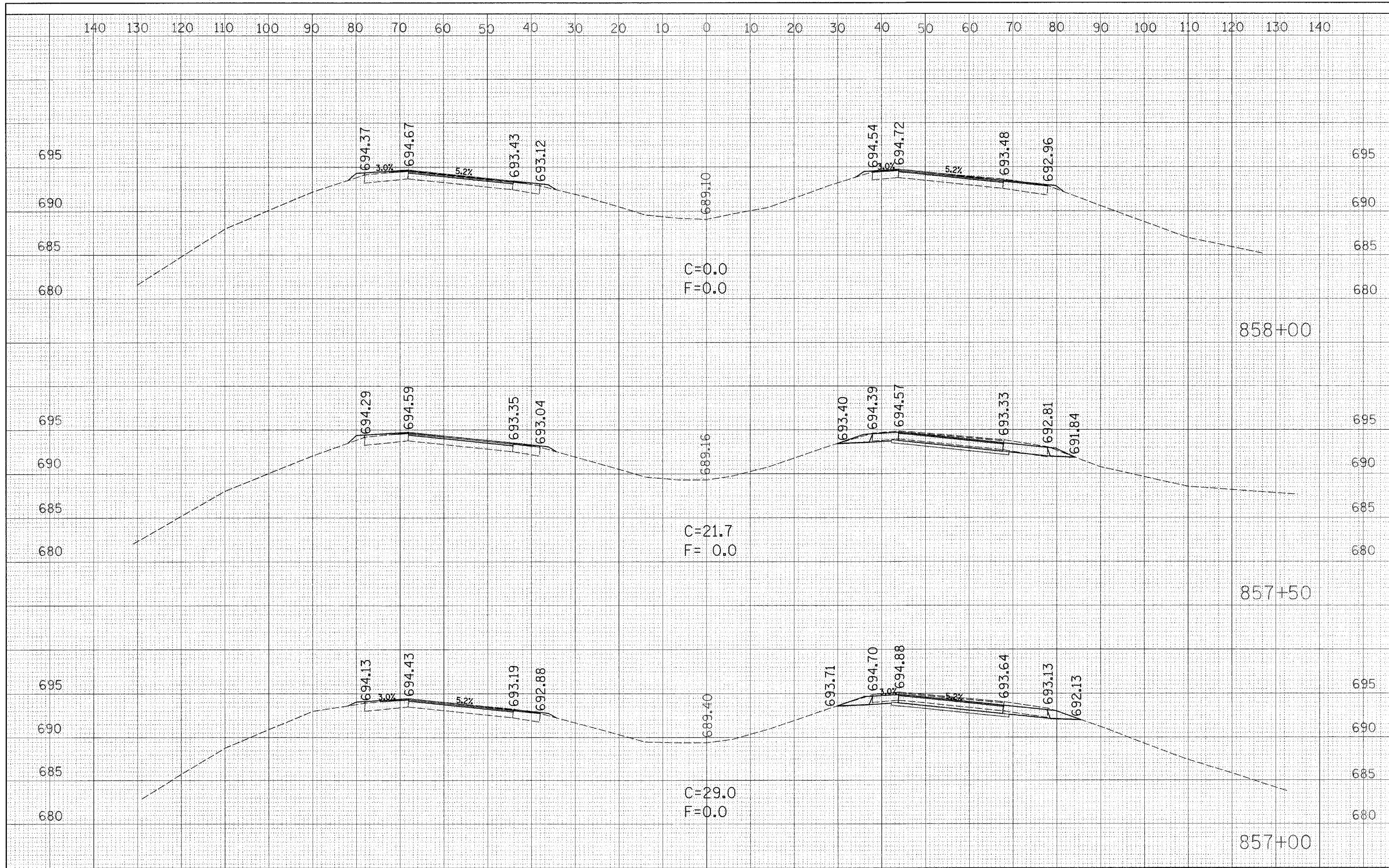

FILE NAME =
e:\projects\74171d\sheet_74171.dgn

USER NAME = davissonjl
PLOT SCALE = 10.0000' / IN.
PLOT DATE = 3/26/2008

DESIGNED - JLD
CHECKED -
DRAWN - JLD
CHECKED -

REVISED -
REVISED -
REVISED -
REVISED -

**STATE OF ILLINOIS
DEPARTMENT OF TRANSPORTATION**

SCALE: 10 SHEET NO. 5 OF 6 SHEETS STA. 857+00 TO STA. 858+00

PAVEMENT PATCH

F.A. RTE.	SECTION	COUNTY	TOTAL SHEETS	SH N
72	(58,74)(66,67)RS-1	MACON	88	8
CONTRACT NO. 741				
FED. ROAD DIST. NO. ILLINOIS FED. AID PROJECT				

