

SYCAMORE ST. TO EAST OF SUMMIT AVE.
STA. 429+95 TO STA. 448+18

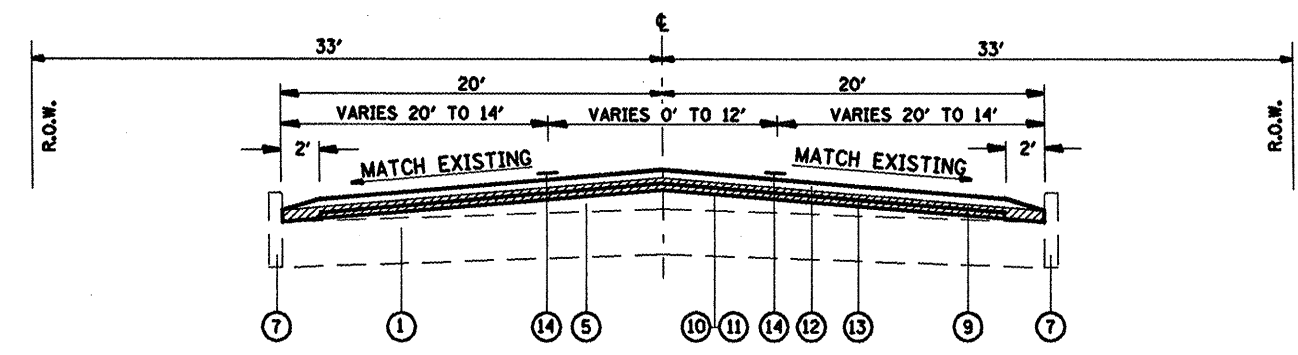

EAST OF CEDAR ST. TO MAIN ST. EOP
STA. 451+19 TO STA. 454+60

•THE EXACT LOCATIONS AND LIMITS FOR PLACEMENT OF STRIP REFLECTIVE CRACK CONTROL TREATMENT SHALL BE DETERMINED BY THE RESIDENT ENGINEER.

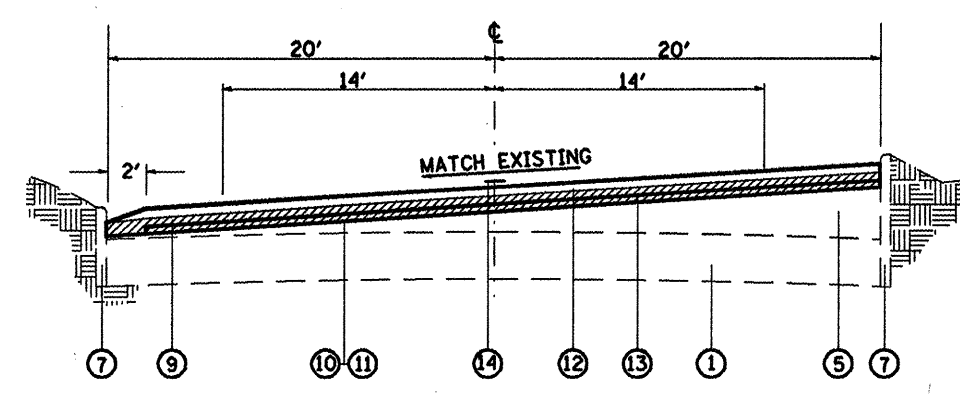

EAST OF SUMMIT AVE. TO EAST OF CEDAR ST.
STA. 448+18 TO STA. 451+19

LEGEND

- ① EXISTING PCC PAVEMENT
- ② CONSTRUCTION JOINT
- ③ METAL JOINT
- ④ 1/2" Ø DEFORMED BAR
- ⑤ EXISTING HOT-MIX ASPHALT RESURFACING
- ⑥ EXISTING TYPE A GUTTER
- ⑦ EXISTING CURB
- ⑧ EXISTING CURB AND GUTTER
- ⑨ PROPOSED HOT-MIX ASPHALT SURFACE REMOVAL 1 1/2"
- ⑩ PROPOSED BITUMINOUS MATERIALS (PRIME COAT)
- ⑪ PROPOSED AGGREGATE (PRIME COAT)
- ⑫ PROPOSED HOT-MIX ASPHALT SURFACE COURSE, MIX "D", N70 - 1 1/2"
- ⑬ PROPOSED LEVELING BINDER (MACHINE METHOD), N70 - 3/4"
- ⑭ PROPOSED THERMOPLASTIC PAVEMENT MARKING - LINE 4"
- ⑮ PROPOSED STRIP REFLECTIVE CRACK CONTROL TREATMENT

NOTE:

EXISTING CURB AND/OR GUTTER WILL BE REMOVED AND REPLACED AT VARIOUS LOCATIONS WITHIN THE PROJECT LIMITS. THIS WORK IS NOT REFLECTED ON THE TYPICAL SECTIONS. REFER TO PLAN SHEETS 11 THRU 20.

FILE NAME =	USER NAME = #USER*	DESIGNED -	REVISED -	STATE OF ILLINOIS DEPARTMENT OF TRANSPORTATION	TYPICAL SECTIONS			F.A.I.L. RTE.	SECTION	COUNTY	TOTAL SHEET NO.
#FILE#		DRAWN -	REVISED -		SCALE:	SHEET NO. OF SHEETS	STA. TO STA.	9128	38-IRS-3	MADISON	33 5
	PLOT SCALE = #SCALE*	CHECKED -	REVISED -					CONTRACT NO. T6A65			
	PLOT DATE = #DATE*	DATE -	REVISED -					FED. ROAD DIST. NO. ILLINOIS FED. AID PROJECT			