

FAP RTE	SECTION	COUNTY	TOTAL SHEETS	SHEET NO.
• 115BR-1, 110BR-1		••	73	17
STA.	TO STA.			
FED. ROAD DIST. NO.	ILLINOIS FED. AID PROJECT AID			
• 776 & 782	•• HAMILTON & WHITE			

DETAILS OF CONCRETE COLLAR PIPE TO PIPE

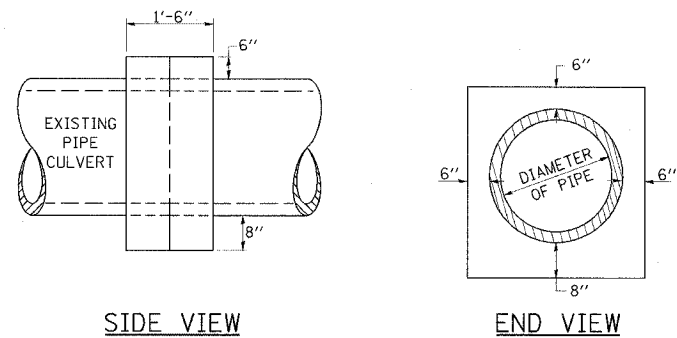

TABULATION

DIAMETER OF PIPE	CL SI CONC CU YDS EST
12"	0.24
15"	0.29
18"	0.32
24"	0.44
30"	0.56
36"	0.66
42"	0.80
48"	0.93
54"	1.07
60"	1.22
72"	1.55

THE CONCRETE COLLAR SHALL BE PAID FOR AT THE CONTRACT UNIT PRICE PER CUBIC YARD FOR **CONCRETE COLLAR**, AS SHOWN ON THE PLANS, WHICH PRICE SHALL INCLUDE THE REMOVAL OF SUCH PORTIONS THE EXISTING HEADWALLS AS MAY BE REQUIRED. CLASS SI CONCRETE SHALL BE USED THROUGHOUT.

REVISIONS
DRAWN 7-15-90
REVISED 8-22-93
STD. 9-79

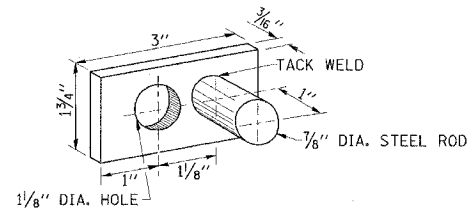
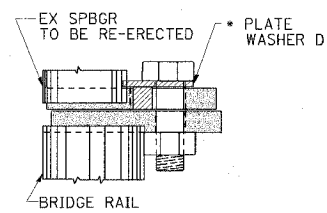

PLATE WASHER D



PLACEMENT OF PLATE WASHER D (PLAN)

• INSTALL PLATE WASHER D SO THAT THE 1" PROJECTION FILLS THE REMAINDER OF THE SLOTTED HOLES IN THE 1" END PLATE AFTER THE 1" DIA. BOLTS ARE IN PLACE

1/8" DIA. HOLES FOR 1" DIA. x 4" ROUND HEAD BOLTS PROVIDE 2 FLAT WASHERS & LOCKNUTS FOR GUARD RAIL CONNECTION

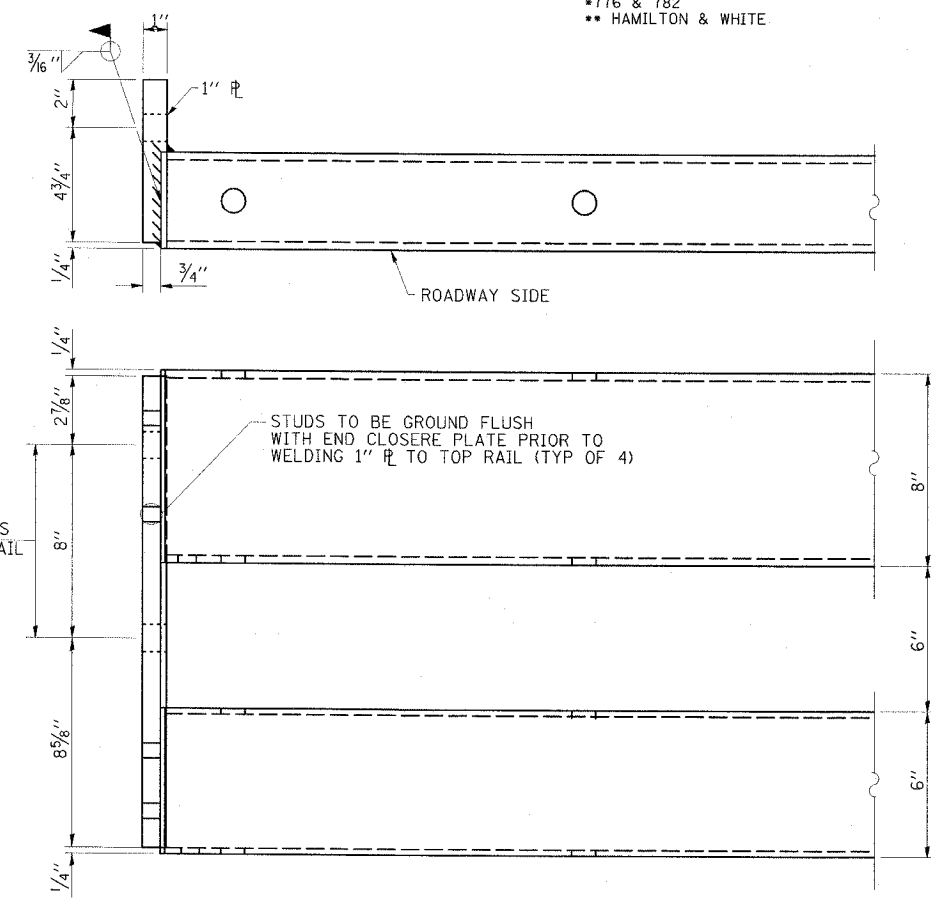

END OF BRIDGE RAIL DETAIL

SPECIAL GUARDRAIL CONNECTION DETAILS

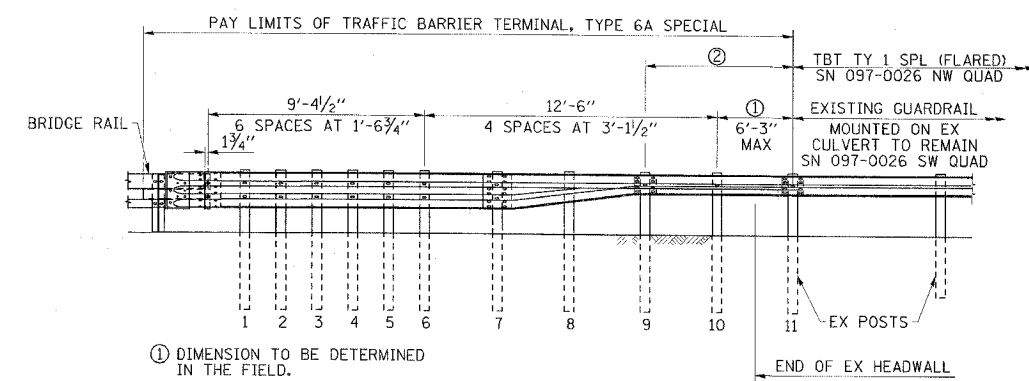

- ① DIMENSION TO BE DETERMINED IN THE FIELD.
- ② OMIT THIS SECTION OF RAIL IN NW QUAD

TBT, TYPE 6A SPECIAL (ONLY AT SN 097-0026)

NOTES: 1. OMIT SINGLE SECTION OF THRIE BEAM SHOWN ON STANDARD 631032.
2. SEE STANDARD 631032 FOR ADDITIONAL DETAILS.

MISCELLANEOUS DETAILS
FAP RTE'S 776 (IL 142) & 782 (IL 1)
SECTIONS 115BR-1 & 110BR-1
HAMILTON & WHITE COUNTIES

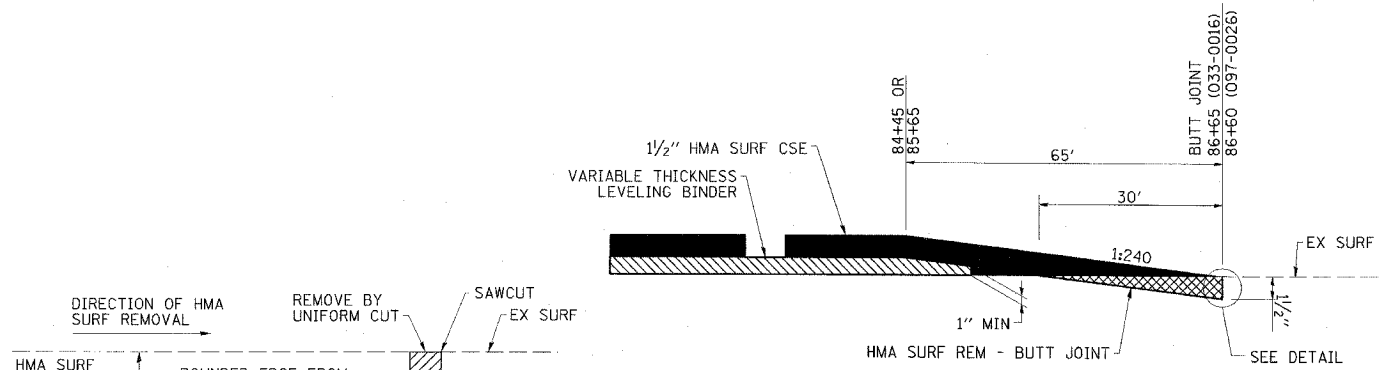

TYPICAL BUTT JOINT SECTION

DETAIL AT BUTT JOINT

NOTE: WHEN MILLING OPERATIONS PRODUCE A ROUNDED EDGE, THEN A SAWCUT SHALL BE USED TO MANUFACTURE A PERPENDICULAR EDGE AS SHOWN IN THE DETAIL. THE COST OF ALL WORK SHOWN IN THE DETAIL IS INCLUDED IN HOT-MIX ASPHALT SURFACE REMOVAL - BUTT JOINT. THE ENGINEER SHALL BE THE SOLE JUDGE CONCERNING THE USE OF THIS DETAIL.

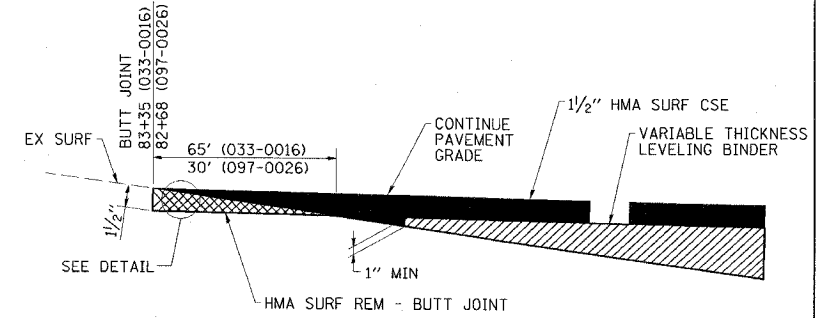

SPECIAL BUTT JOINT SECTION

ESCA
CONSULTANTS, INC.

DESIGNED BY:	DAJ	09/07
DRAWN BY:	HAS	09/07
CHECKED BY:	JMS/MTD	01/08
APPROVED BY:	RDP	02/08