

DETAIL OF AGGREGATE PRIVATE OR COMMERCIAL ENTRANCE

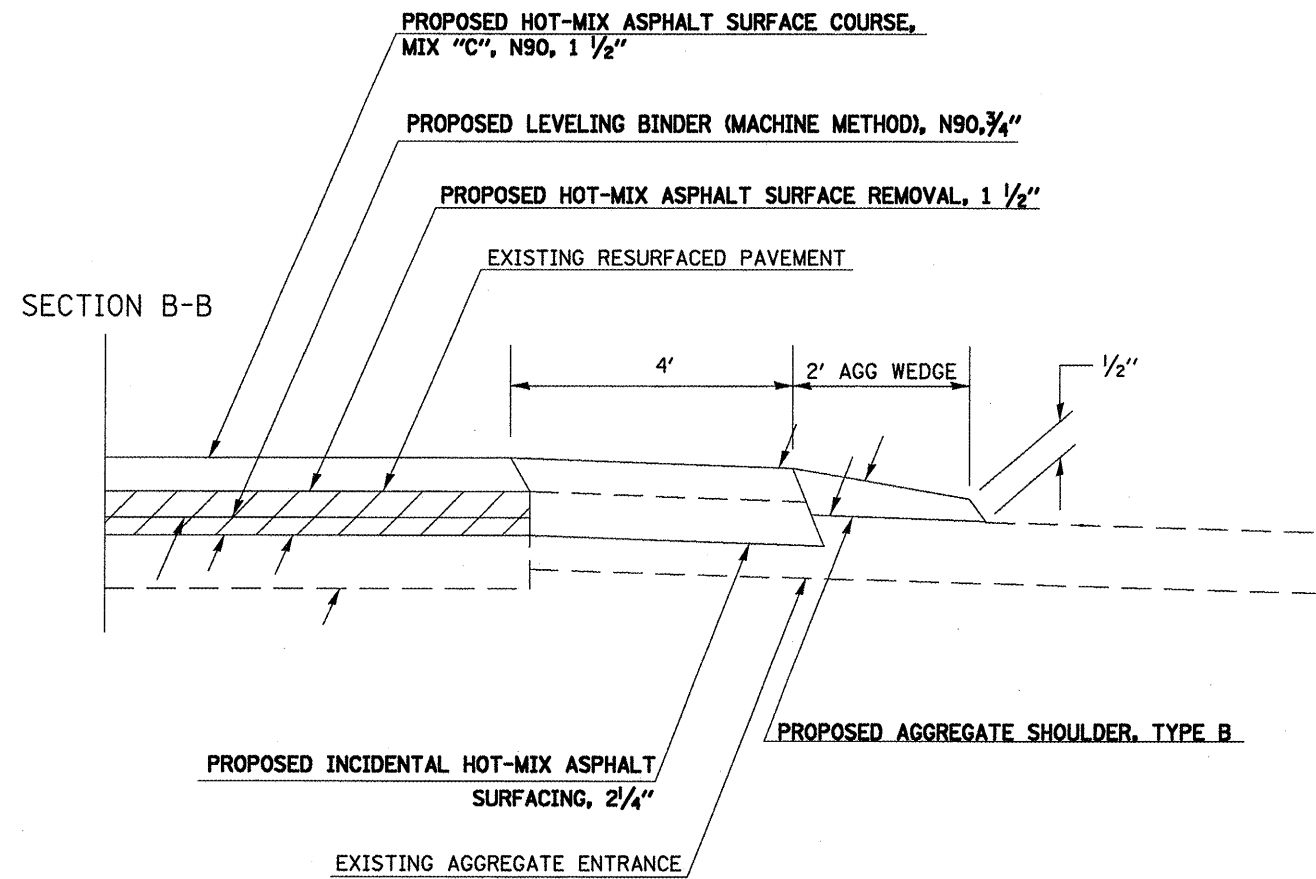
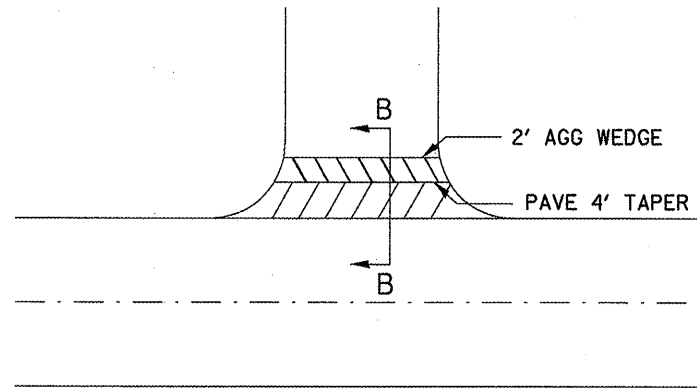

VARIABLE SHAPING IS INCLUDED IN THE COST OF INCIDENTAL HOT-MIX ASPHALT SURFACING.

PREPARATION OF EXISTING SURFACE AND ANY EXCAVATION FOR ENTRANCES SHALL BE IN ACCORDANCE WITH ARTICLE 406.09 OF THE STANDARD SPECIFICATIONS.

THE ABOVE QUANTITIES HAVE BEEN INCLUDED IN THE SUMMARY OF QUANTITIES.

DETAIL OF HOT-MIX ASPHALT OR P.C.C. PRIVATE OR COMMERCIAL ENTRANCE

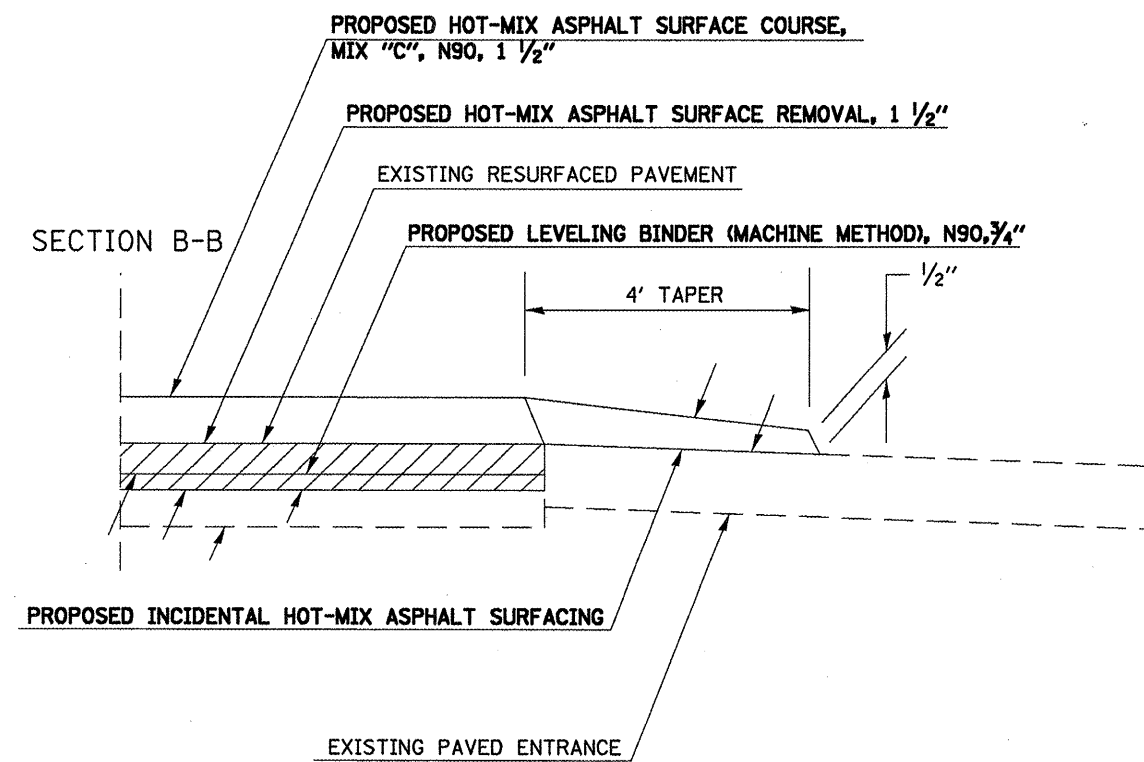
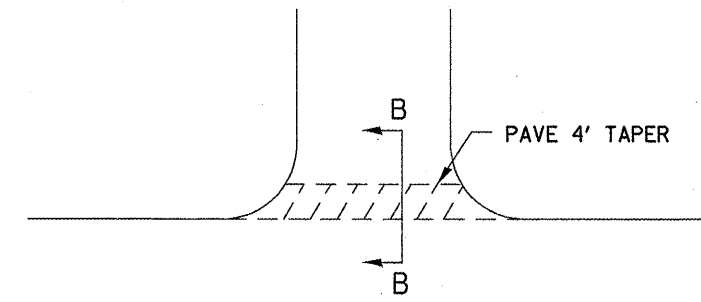

PREPARATION OF EXISTING SURFACE AND ANY EXCAVATION FOR ENTRANCES SHALL BE IN ACCORDANCE WITH ARTICLE 406.09 OF THE STANDARD OF SPECIFICATIONS.

THE ABOVE QUANTITIES HAVE BEEN INCLUDED IN THE SUMMARY OF QUANTITIES.

FILE NAME =
c:\projeots\78844\78844-miso.dgn

USER NAME = eolmm

DESIGNED -

REVISED -

DRAWN -

REVISED -

PLOT SCALE = 100.0000' / IN.

CHECKED -

REVISED -

PLOT DATE = 3/11/2008

DATE -

REVISED -

**STATE OF ILLINOIS
DEPARTMENT OF TRANSPORTATION**

ENTRANCE DETAILS

SCALE: NONE

SHEET NO. 1 OF 2 SHEETS

STA.

TO STA.

F.A.P. RTE.	SECTION	COUNTY	TOTAL SHEETS	SHEET NO.
726	(119,120)RS-3	JEFFERSON	16	11
CONTRACT NO. 78044				
FED. ROAD DIST. NO. ILLINOIS FED. AID PROJECT				