

ROUTE NO.	SECTION	COUNTY	TOTAL SHEETS	SHEET NO.
FAS 666	99-00080-00-RP	DOUGLAS	279	101
FEDERAL DIST. NO.	ILLINOIS	PROJECT	C-95-323-07	

**GENERAL NOTES:**

COMMERCIAL ENTRANCES SHALL BE CONSTRUCTED WITH 3 1/2 " HMA OVER 6" AGGREGATE BASE COURSE, TY B.

PRIVATE ENTRANCES SHALL BE CONSTRUCTED WITH 2 1/2" HMA OVER 6" AGGREGATE BASE COURSE, TY B.

THE SHOULDER, SUB-BASE GRANULAR MATL, TYPE A, SHALL BE CONSTRUCTED PRIOR TO ENTRANCE CONSTRUCTION. THE CONTRACTOR SHALL GRADE THE SUB-BASE GRANULAR MATL, TYPE A, TO THE PROPER GRADE FOR EACH TYPE OF ENTRANCE BEING CONSTRUCTED. THE EXCAVATED SUB-BASE GRANULAR MATERIAL SHALL BE DEPOSITED WITHIN THE LIMITS OF THE PROPOSED ENTRANCE AS AN AGGREGATE BASE. THIS REQUIREMENT SHALL NOT BE PAID FOR SEPARTELY BUT SHALL BE INCLUDED IN OTHER ITEMS OF RELATED CONSTRUCTION.

**COMMERCIAL - PRIVATE DRIVE  
TYPICAL DETAIL**

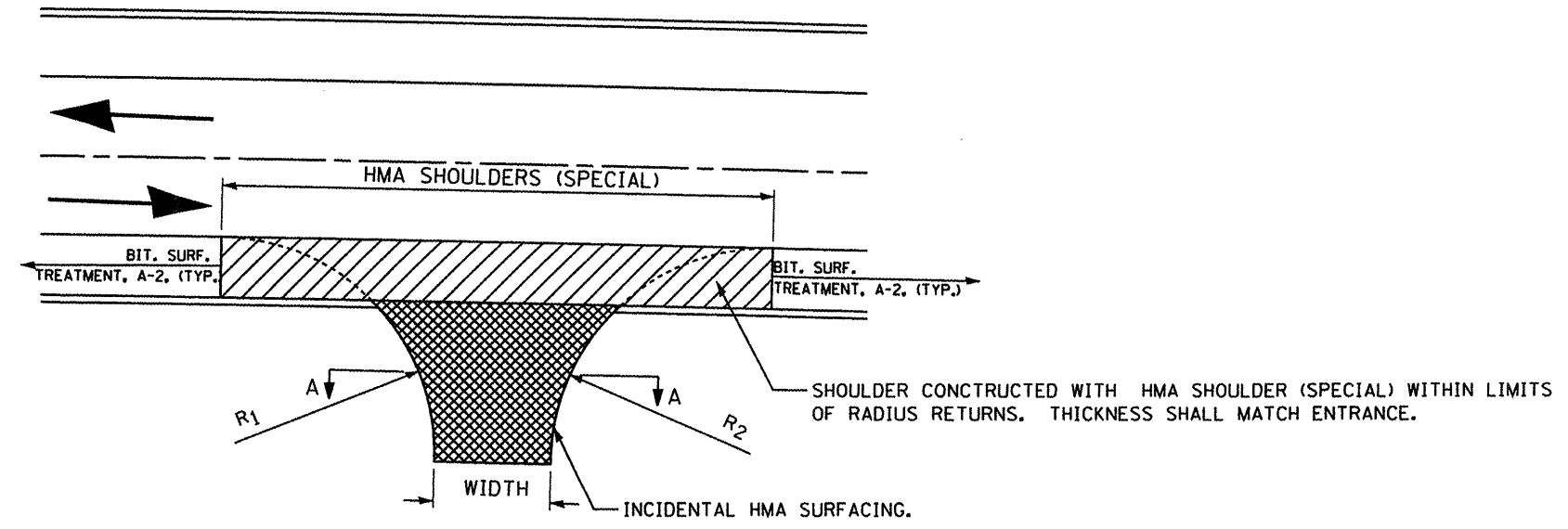

**GENERAL NOTES:**

FIELD ENTRANCES SHALL BE CONSTRUCTED WITH 2 1/2" HMA OVER 6" AGGREGATE BASE COURSE, TY B.

THE SHOULDER, SUB-BASE GRANULAR MATL, TYPE A, SHALL BE CONSTRUCTED PRIOR TO ENTRANCE CONSTRUCTION. THE CONTRACTOR SHALL GRADE THE SUB-BASE GRANULAR MATL, TYPE A, TO THE PROPER GRADE FOR EACH TYPE OF ENTRANCE BEING CONSTRUCTED. THE EXCAVATED SUB-BASE GRANULAR MATERIAL SHALL BE DEPOSITED WITHIN THE LIMITS OF THE PROPOSED ENTRANCE AS AN AGGREGATE BASE. THIS REQUIREMENT SHALL NOT BE PAID FOR SEPARTELY BUT SHALL BE INCLUDED IN OTHER ITEMS OF RELATED CONSTRUCTION.

**FIELD ENTRANCE  
TYPICAL DETAIL**

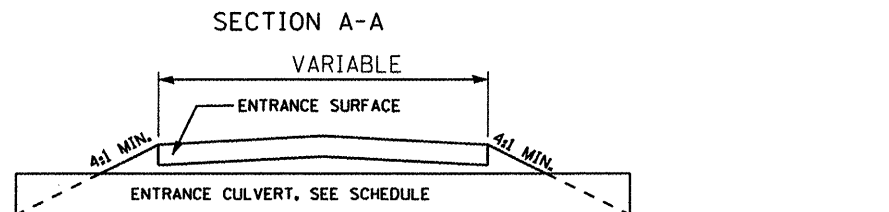
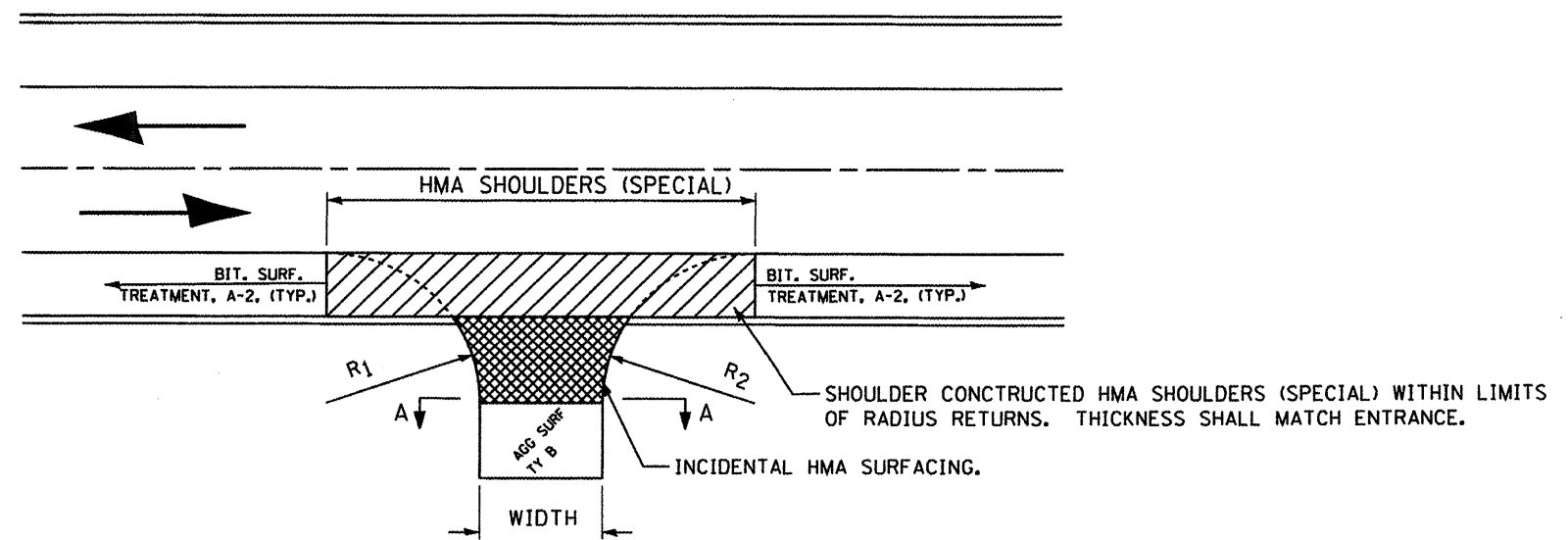

ENTRANCE SURFACE SHALL BE CONSTRUCTED AS PER THE SCHEDULES AND TYPE OF ENTRANCE BEING CONSTRUCTED.

**MISC DETAILS**

Revisions	Surveyed: DLE	<b>FAS ROUTE 666 (CH 11) DOUGLAS COUNTY, ILLINOIS</b>  <b>DOUGLAS COUNTY HIGHWAY DEPARTMENT TUSCOLA, ILLINOIS</b>
1. DATE INITIALS	Designed: JEC	
2.	Drawn: JEC	
3.	Checked: ---	
4.	Approved: JEC	
5.		
6.		
Job No.: NA	Date: 1/08	

ROUTE NO.	SECTION	COUNTY	TOTAL SHEETS	SHEET NO.
FAS 666	99-00080-00-RP	DOUGLAS	279	102
FEDERAL DISTRICT...	ILLINOIS	PROJECT	C-95-323-07	

### HMA SURFACE REMOVAL, BUTT JOINT DETAIL

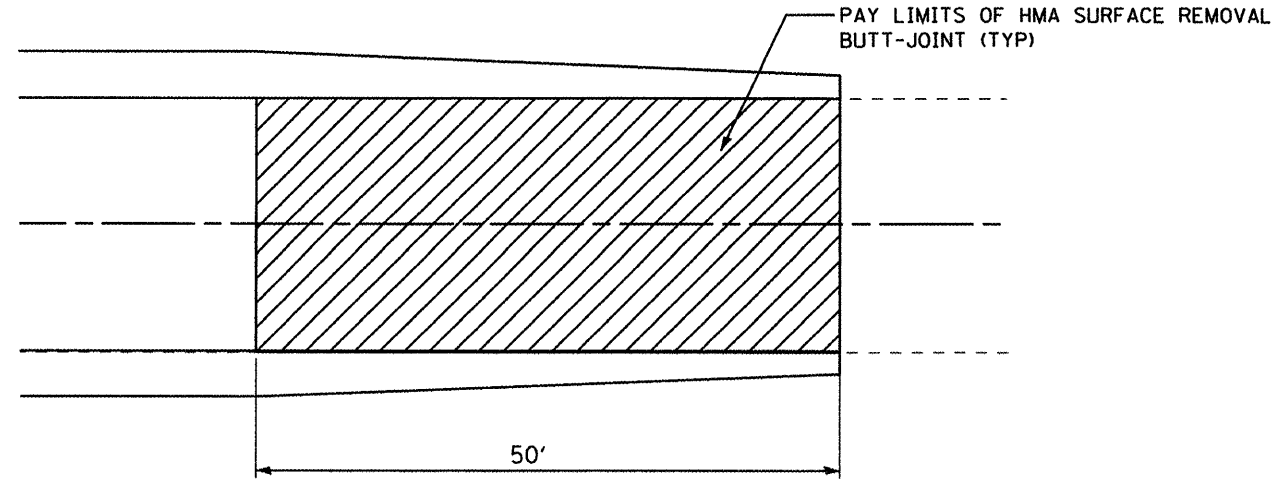

PLAN VIEW

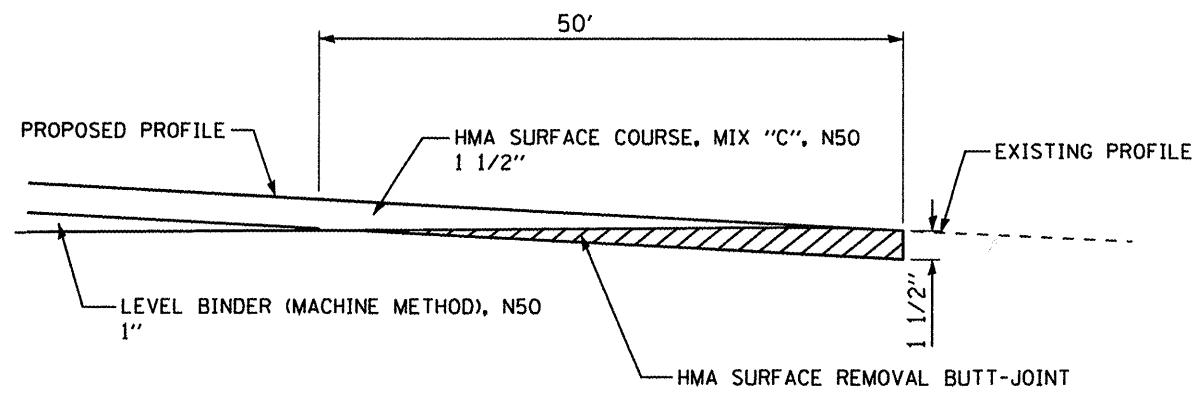

PROFILE VIEW

### COMBINATION CURB & GUTTER B6.24 FLARED INLET/OUTLET

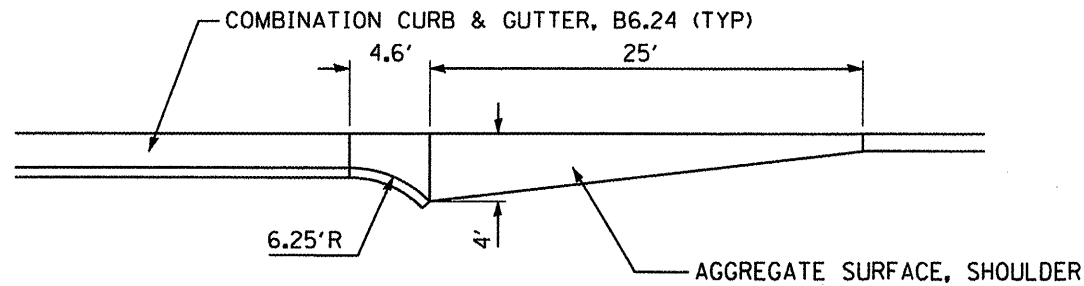

### Z0030900 INSPECTION WELLS

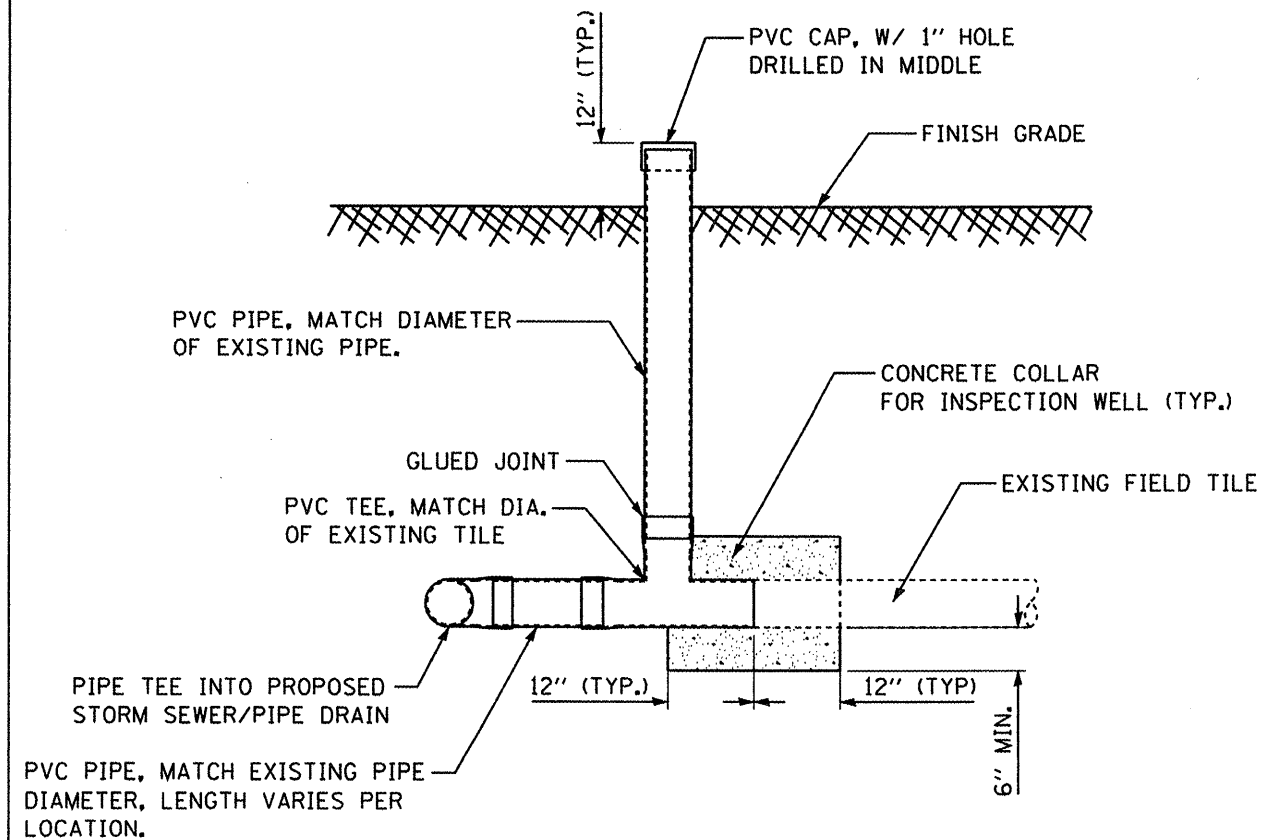

CONCRETE COLLAR FOR INSPECTION WELLS

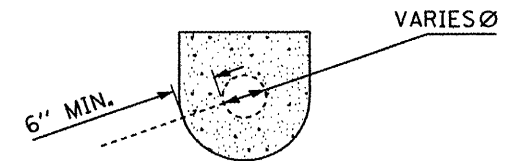

#### GENERAL NOTES:

ALL ITEMS REQUIRED TO CONSTRUCT THE INSPECTION WELL TO INCLUDE THE CONCRETE COLLAR SHALL BE PAID FOR AT THE CONTRACT UNIT COST FOR INSPECTION WELL, EACH. NO ADDITIONAL COMPENSATION WILL BE ALLOWED.

THE PIPE DIAMETER SHALL BE DETERMINED BY THE SIZE OF THE EXISTING FIELD TILE-PIPE DRAIN THAT IS BEING TIED INTO THE PROPOSED PIPE DRAIN-STORM SEWER.

#### MISC DETAILS

Revisions	Surveyed:	DLE
1	Designed:	JEC
2	Drawn:	JEC
3	Checked:	---
4	Approved:	JEC
5		
Job No.:	NA	Date:
		1/08

FAS ROUTE 666 (CH 11)  
DOUGLAS COUNTY, ILLINOIS

DOUGLAS COUNTY HIGHWAY  
DEPARTMENT  
TUSCOLA, ILLINOIS

ROUTE NO.	SECTION	COUNTY	TOTAL SHEETS	SHEET NO.
FAS 666	99-00080-00-RP	DOUGLAS	279	103
FEDERAL DISTRICT		ILLINOIS	PROJECT	C-95-323-07

DATE	BY

  

NO.	AREAS CHECKED	NOTE BOOK	TEMPLATE	PLOTTED	SKETCHED	FINAL SURVEY

DATE	BY

NO.	AREAS CHECKED	NOTE BOOK	TEMPLATE	PLOTTED	SKETCHED	ORIGINAL SURVEY

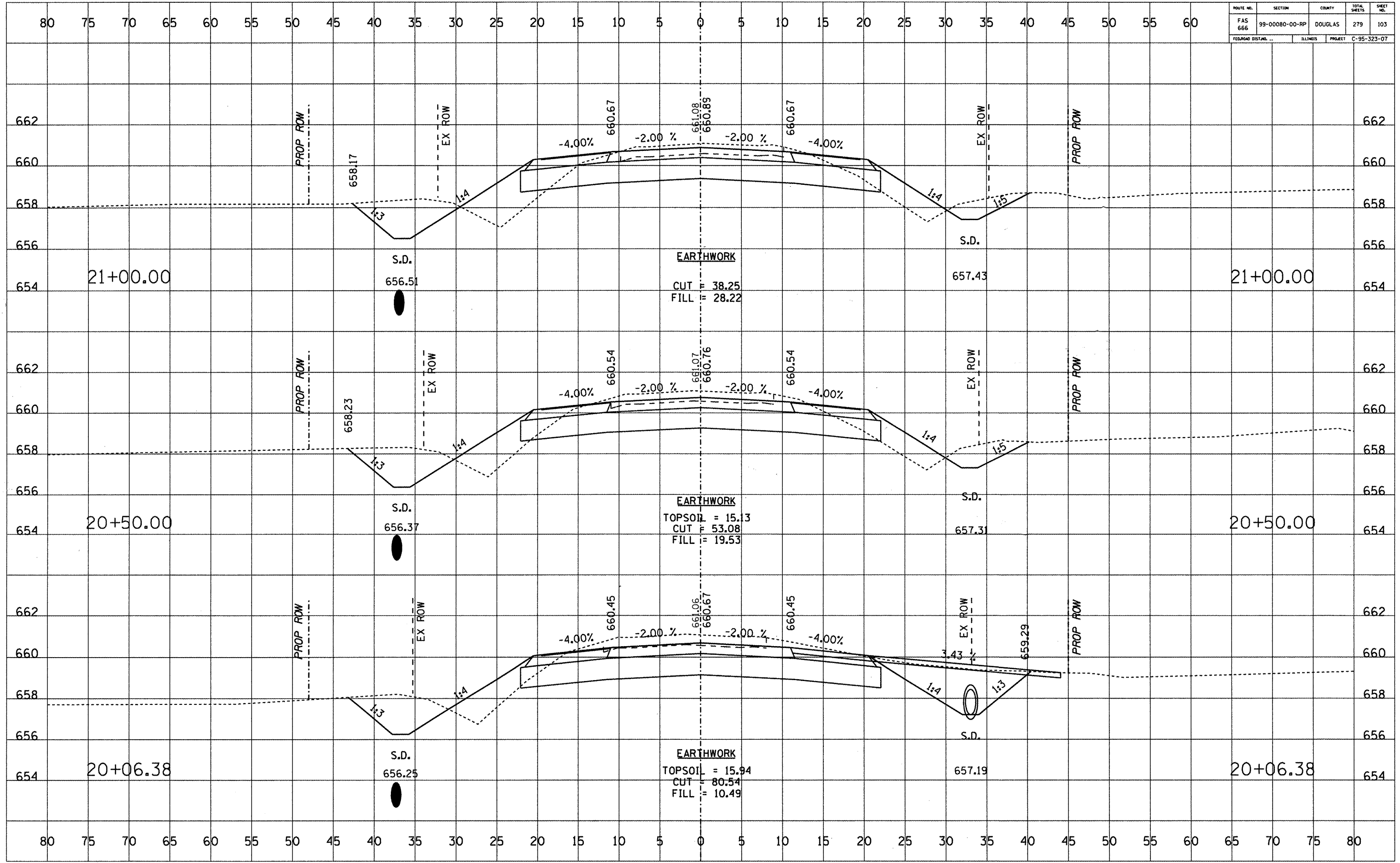

ROUTE NO.	SECTION	COUNTY	TOTAL SHEETS	SHEET NO.
FAS 666	99-00080-00-RP	DOUGLAS	279	104
FEDERAL DISTRICT		ILLINOIS	PROJECT C-95-323-07	

DATE	
BY	
SURVEYED	
PLOTTED	
TEMPLATE	
NOTE BOOK	
AREAS CHECKED	
NO.	

DATE	
BY	
ORIGINAL SURVEY	
PLOTTED	
TEMPLATE	
NOTE BOOK	
AREAS CHECKED	
NO.	

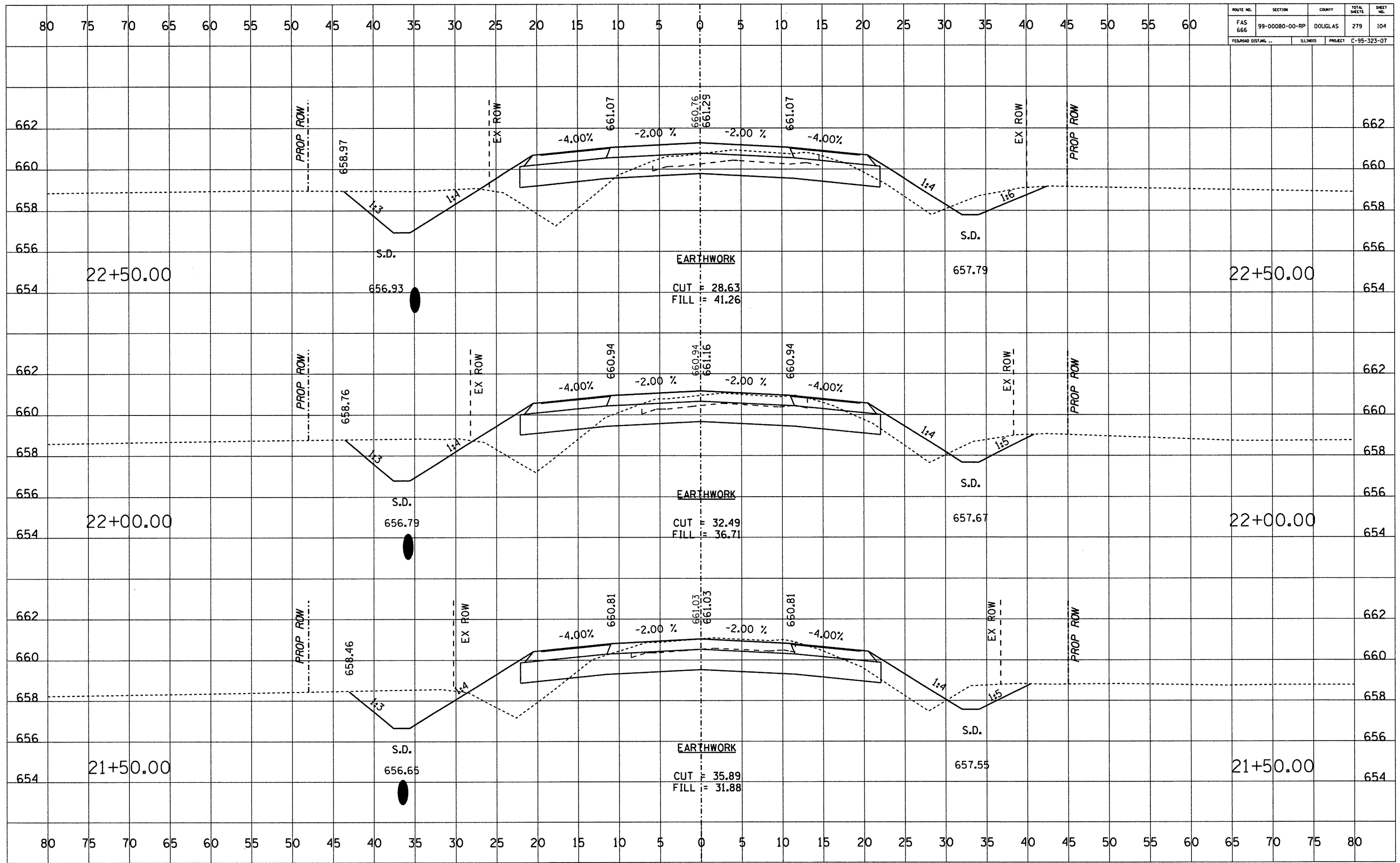

ROUTE NO.	SECTION	COUNTY	TOTAL SHEETS	SHEET NO.
FAS 666	99-00080-00-RP	DOUGLAS	279	105
FIGURE DISTANCE		ILLINOIS	PROJECT C-95-323-07	

DATE	BY

DATE	BY

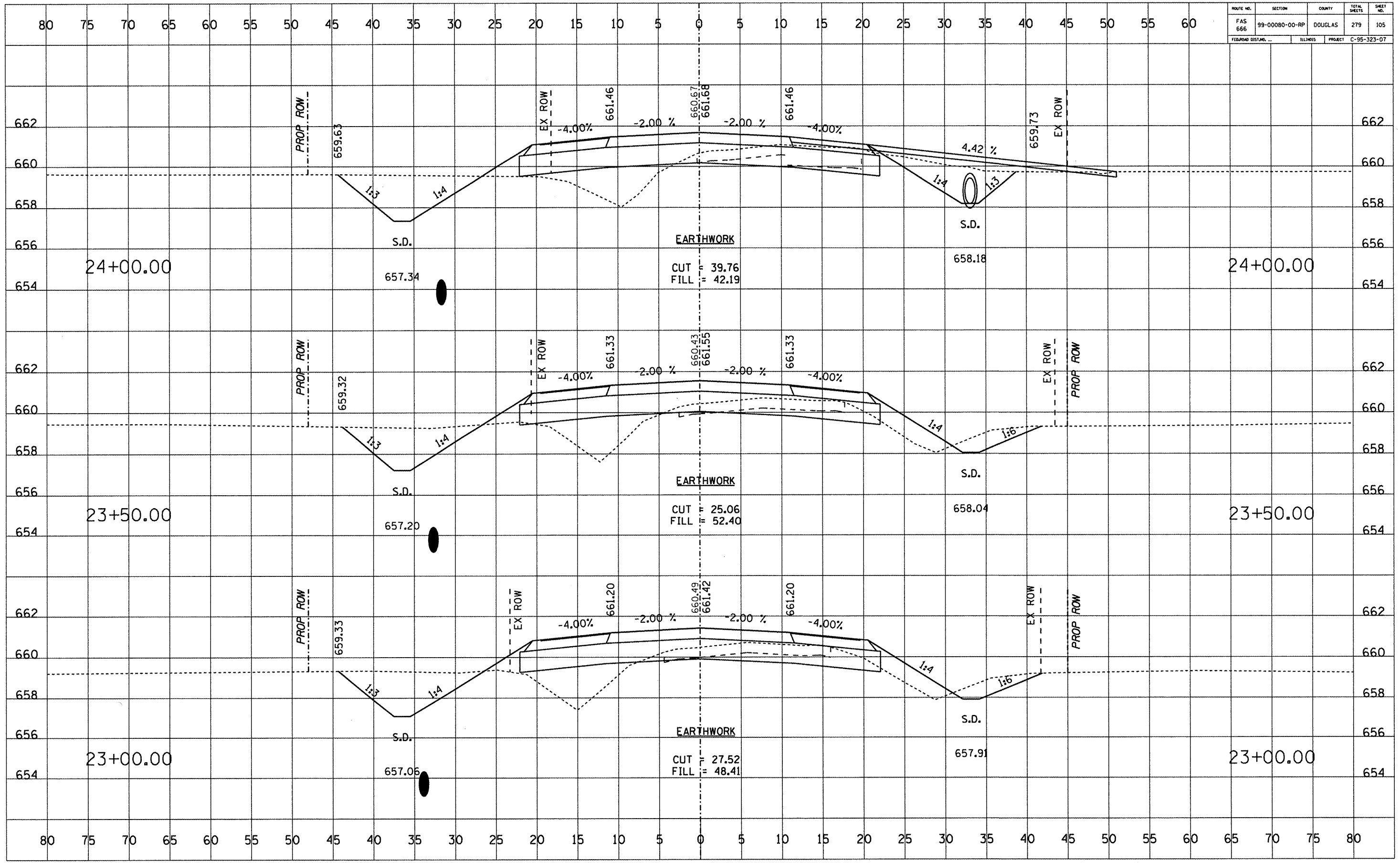

ROUTE NO.	SECTION	COUNTY	TOTAL SHEETS	SHEET NO.
FAS 666	99-00080-00-RP	DOUGLAS	279	106
FEDERAL DISTRICT...		ILLINOIS	PROJECT C-95-323-07	

80 75 70 65 60 55 50 45 40 35 30 25 20 15 10 5 0 5 10 15 20 25 30 35 40 45 50 55 60

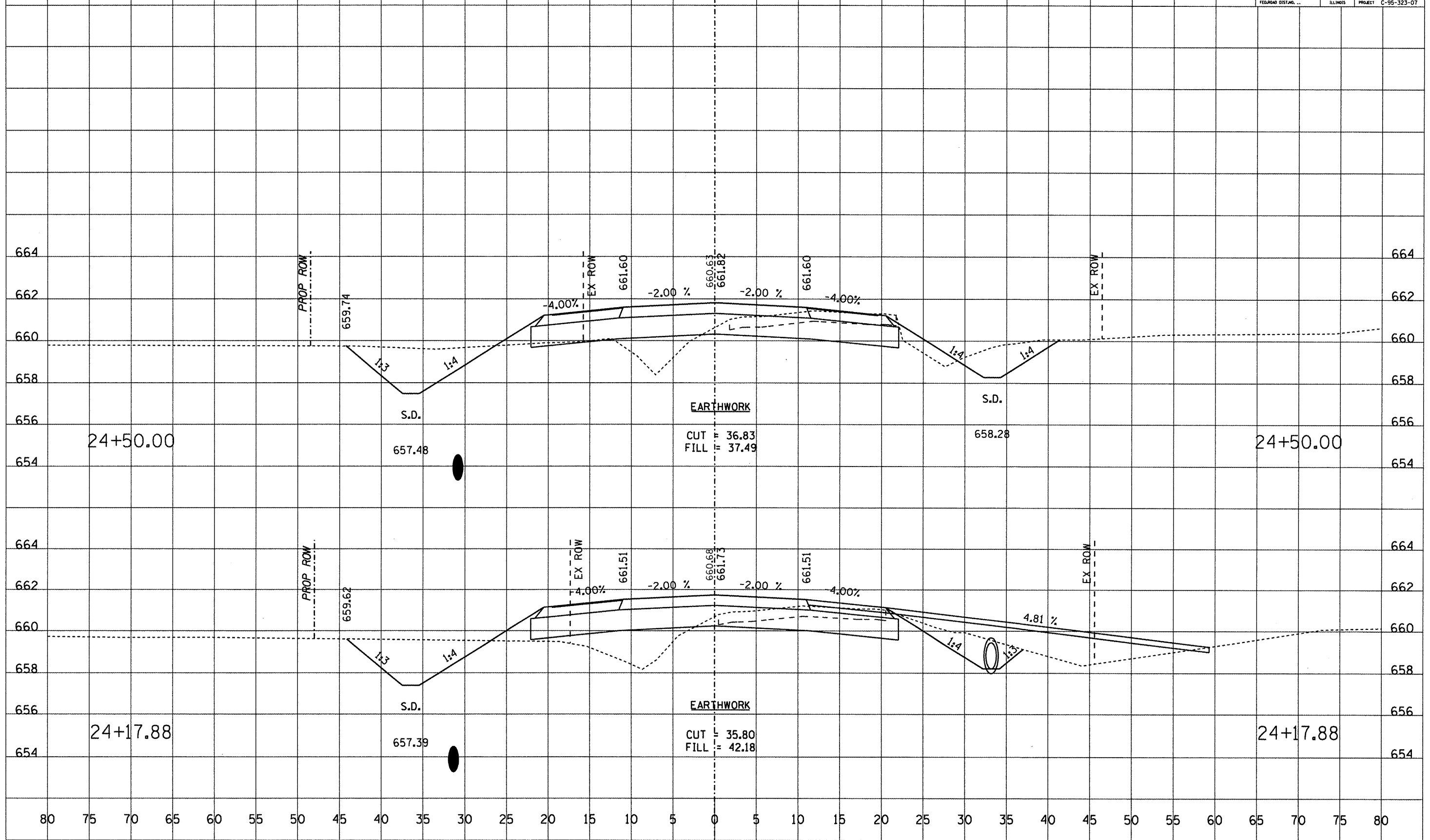

DATE	BY

DATE	BY

ROUTE NO.	SECTION	COUNTY	TOTAL SHEETS	SHEET NO.
FAS 666	99-00080-00-RP	DOUGLAS	279	107
FEDERAL DIST. NO. ...		ILLINOIS	PROJECT C-95-323-07	

DATE	BY

FINAL SURVEY	SURVEYED	PLOTTED	RECALCULATE	AREAS CHECKED

DATE	BY

ORIGINAL SURVEY	SURVEYED	PLOTTED	RECALCULATE	AREAS CHECKED

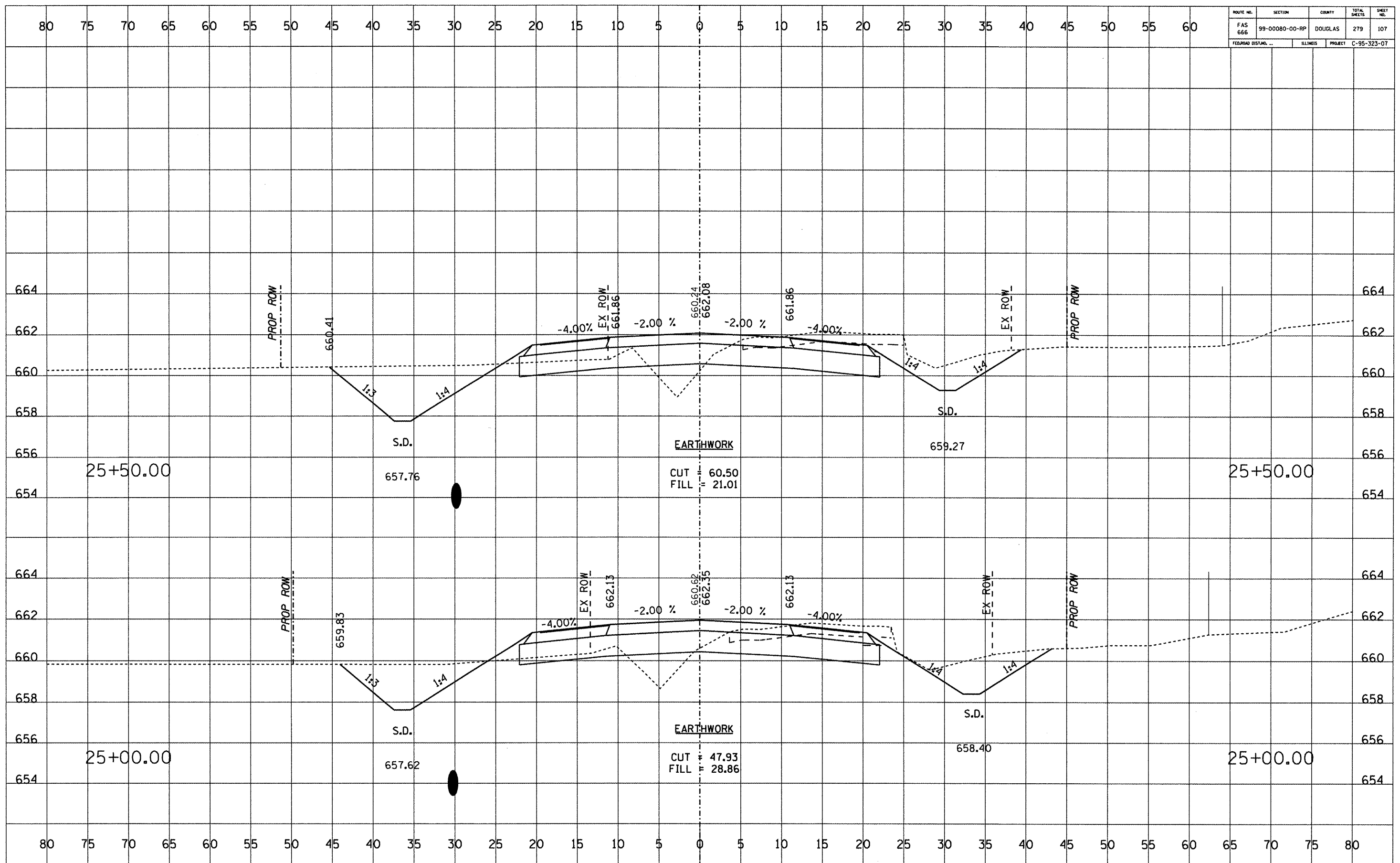

ROUTE NO.	SECTION	COUNTY	TOTAL SHEETS	SHEET NO.
FAS 666	99-00080-00-RP	DOUGLAS	279	108
FEDERAL DIST. NO. ...		ILLINOIS	PROJECT C-95-323-07	

DATE	BY	NO.
FINAL SURVEY	SKETCHED	PLOTTED
NOTE BOOK	TEMPLATE	AREAS CHECKED

DATE	BY	NO.
ORIGINAL SURVEY	SKETCHED	PLOTTED
NOTE BOOK	TEMPLATE	AREAS CHECKED

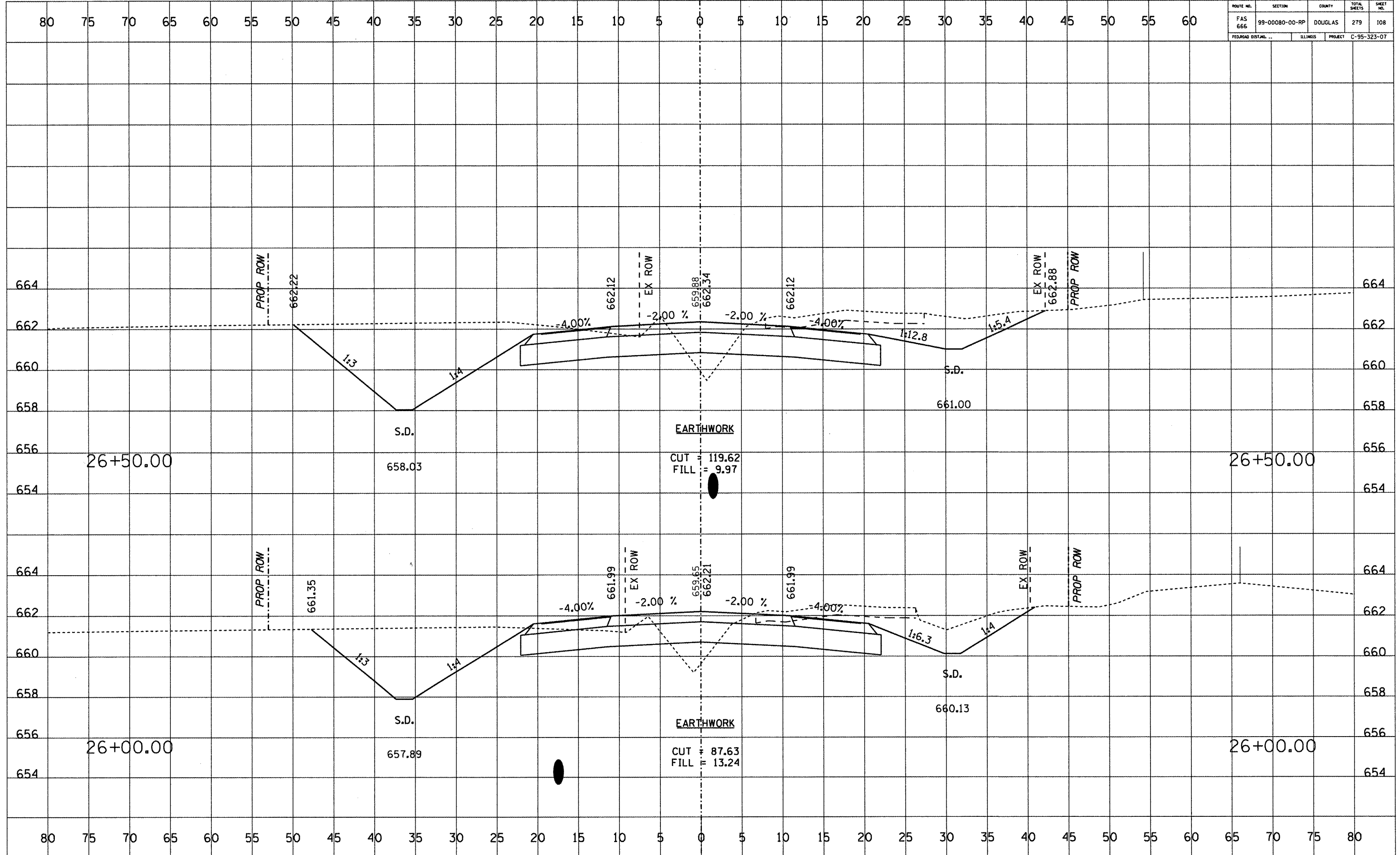



ROUTE NO.	SECTION	COUNTY	TOTAL SHEETS	SHEET NO.
FAS 666	99-00080-00-RP	DOUGLAS	279	109
FEDERAL DIST. NO.	ILLINOIS	PROJECT	C-95-323-07	

DATE	
BY	
SURVEYED	
PLOTTED	
TEMPLATE	
NOTE BOOK	
NO.	
AREAS CHECKED	

DATE	
BY	
SURVEYED	
PLOTTED	
TEMPLATE	
NOTE BOOK	
NO.	
AREAS CHECKED	

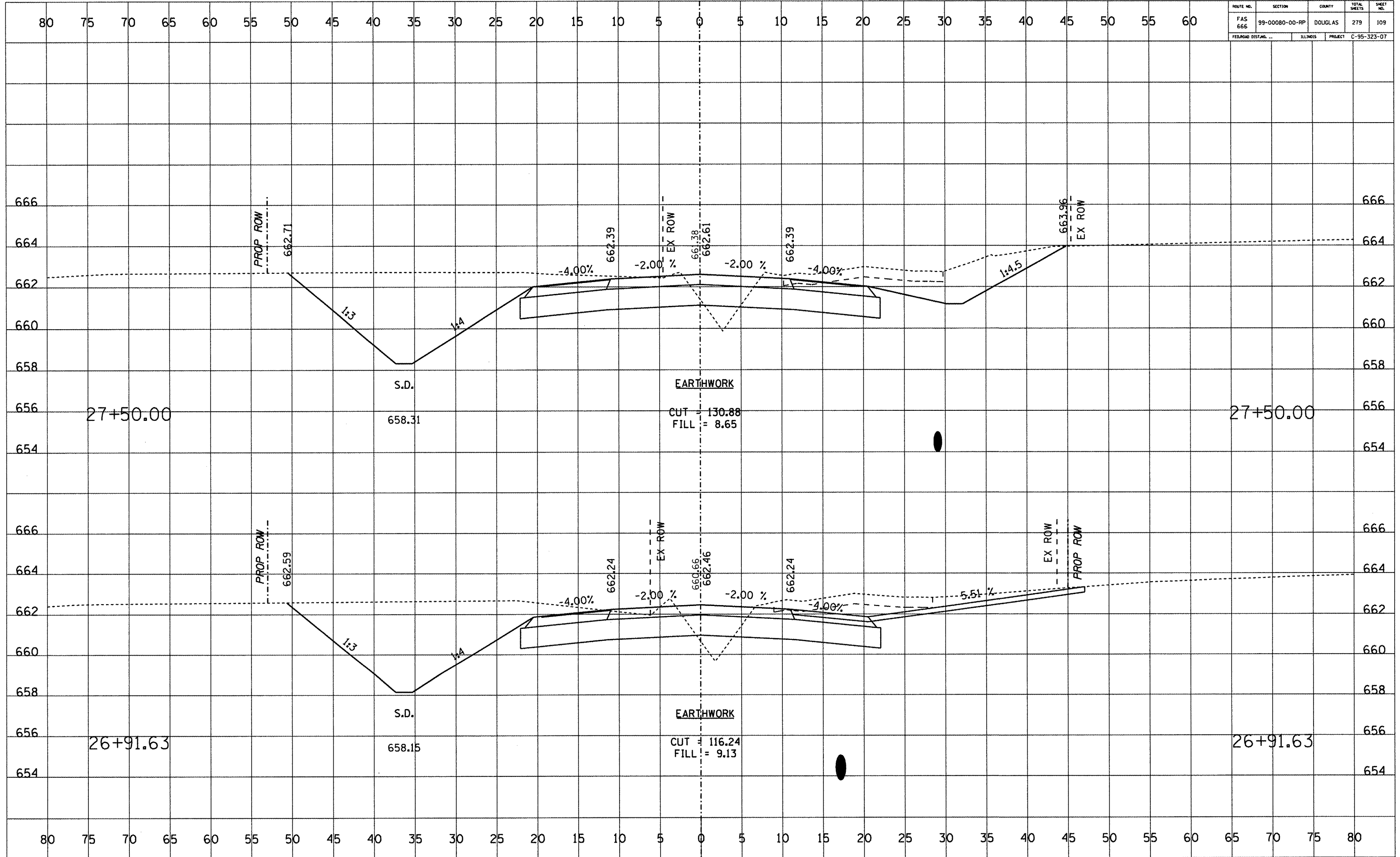

ROUTE NO.	SECTION	COUNTY	TOTAL SHEETS	SHEET NO.
FAS 666	99-00080-00-RP	DOUGLAS	279	110
FEDERAL DIST. NO.	ILLINOIS	PROJECT	C-95-323-07	

DATE	
BY	
FINAL SURVEY	
NOTE BOOK NO.	
SURVEYED	
PLOTTED	
TEMPLATE	
AREAS CHECKED	

DATE	
BY	
ORIGINAL SURVEY	
NOTE BOOK NO.	
SURVEYED	
PLOTTED	
TEMPLATE	
AREAS CHECKED	

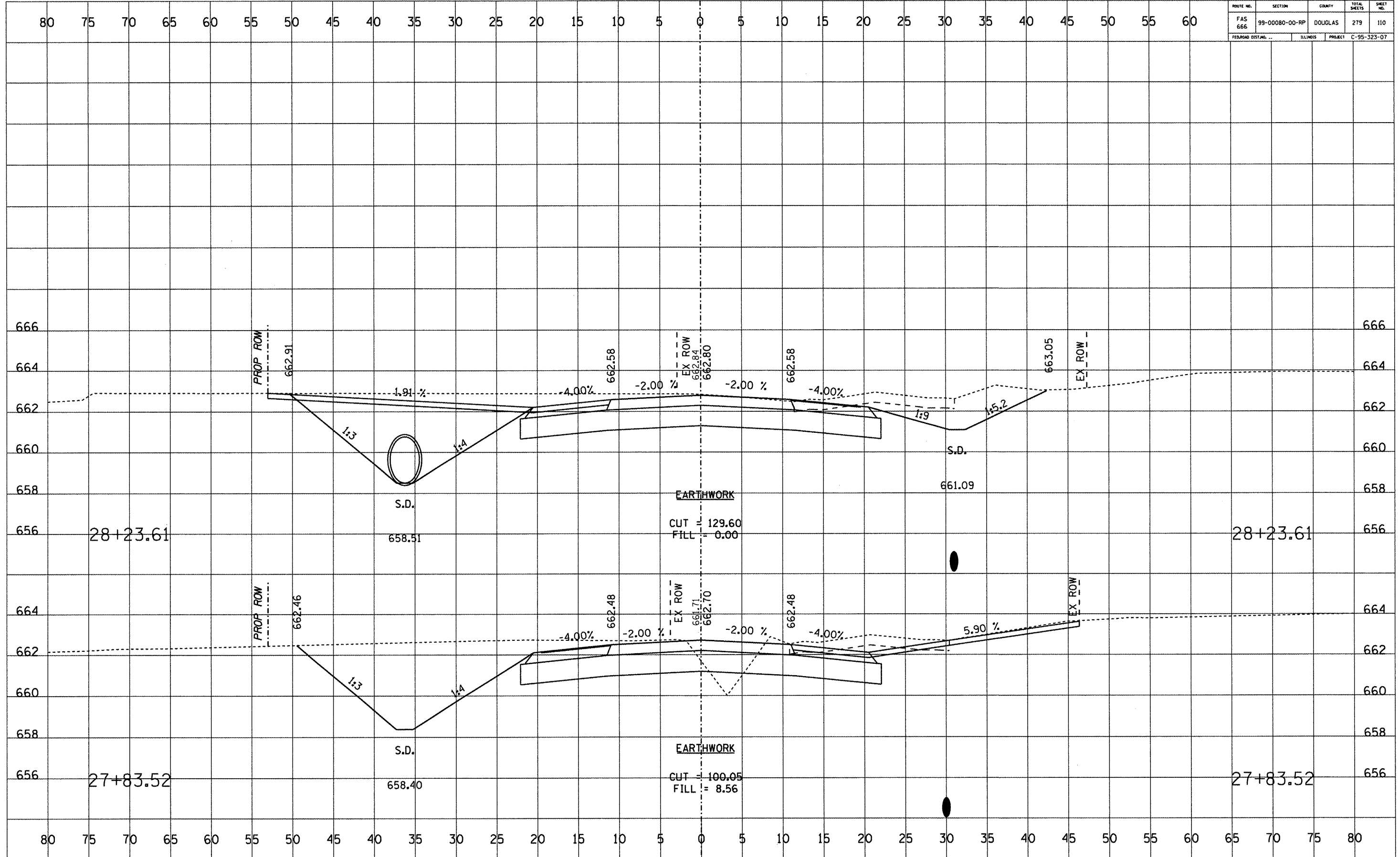

ROUTE NO.	SECTION	COUNTY	TOTAL SHEETS	SHEET NO.
FAS 666	99-00080-00-RP	DOUGLAS	279	111
FEDERAL DISTRICT		ILLINOIS	PROJECT C-95-323-07	

DATE	
BY	
FINAL SURVEY	
NOTED	
PLOTTED	
TEMPLATE	
NO. BOOK	
AREAS CHECKED	

DATE	
BY	
ORIGINAL SURVEY	
NOTED	
PLOTTED	
TEMPLATE	
NO. BOOK	
AREAS CHECKED	

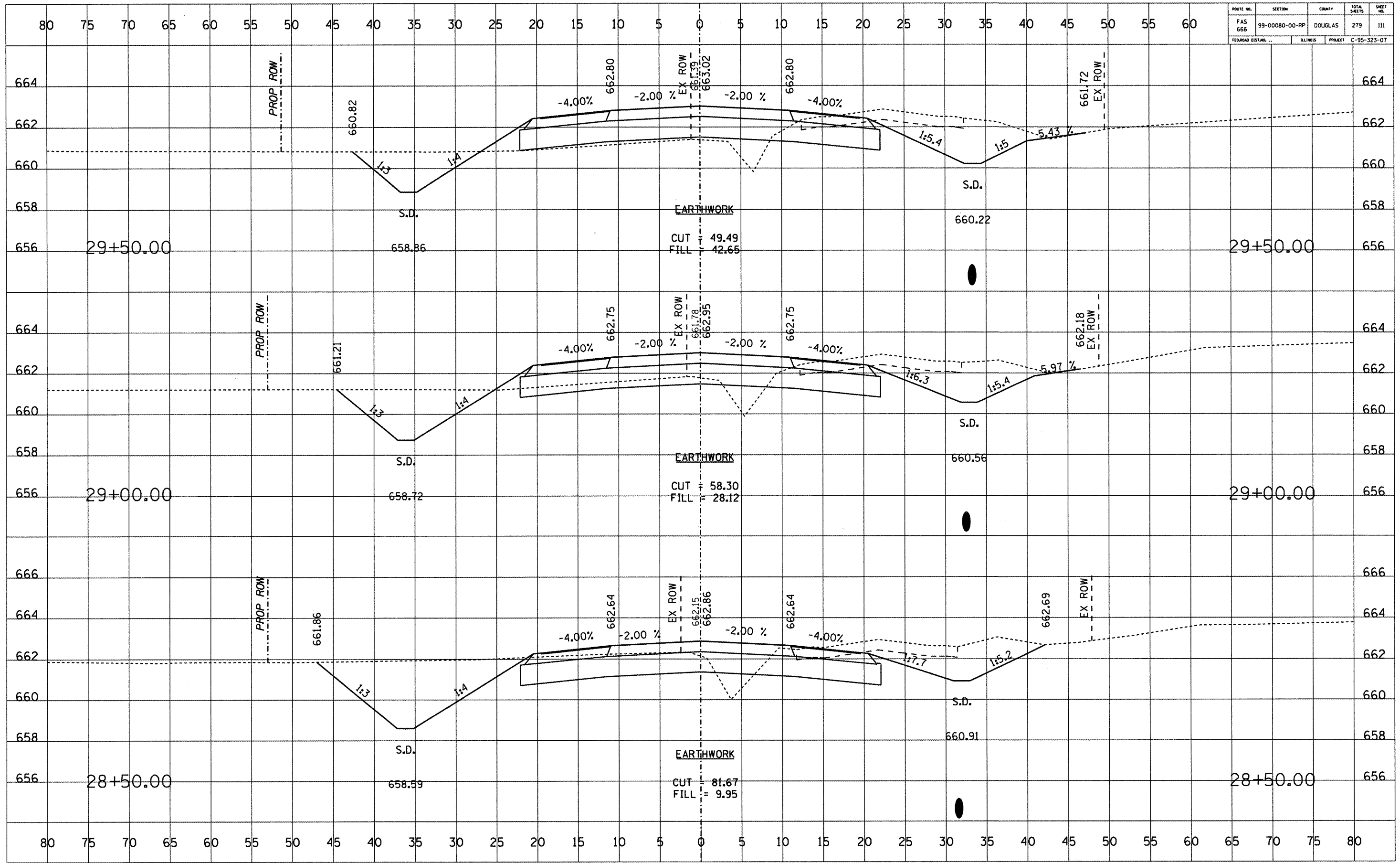

ROUTE NO.	SECTION	COUNTY	TOTAL SHEETS	SHEET NO.
FAS 666	99-00080-00-RP	DOUGLAS	279	112
FEDERAL DIST. NO.	ILLINOIS	PROJECT	C-95-323-07	

80 75 70 65 60 55 50 45 40 35 30 25 20 15 10 5 0 5 10 15 20 25 30 35 40 45 50 55 60

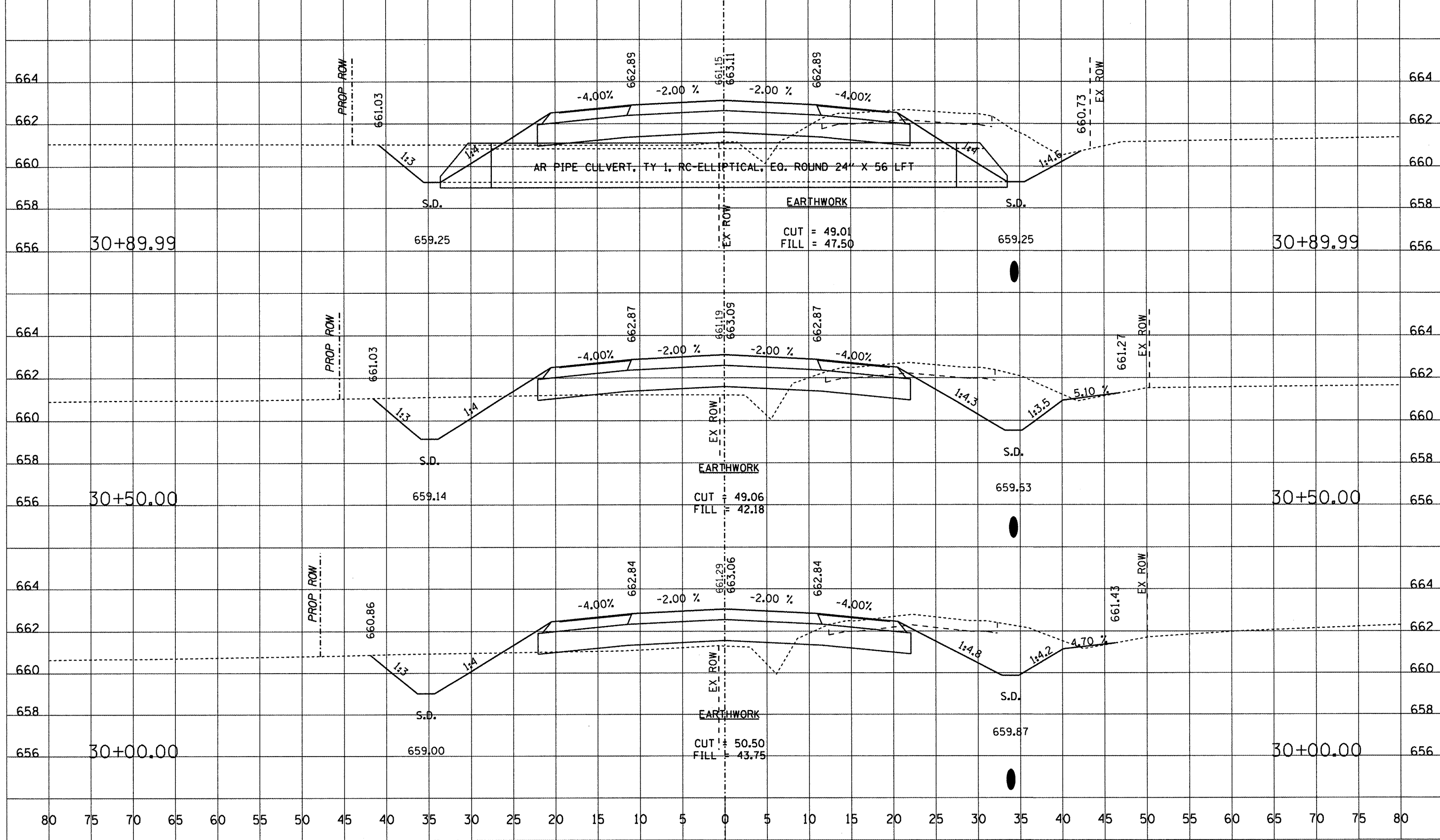

DATE	BY

DATE	BY

ROUTE NO.	SECTION	COUNTY	TOTAL SHEETS	SHEET NO.
FAS 666	99-00080-00-RP	DOUGLAS	279	113
FEDERAL DIST. NO.		ILLINOIS	PROJECT	C-95-323-07

DATE	BY

  

NO.	AREAS CHECKED

DATE	BY

NO.	AREAS CHECKED

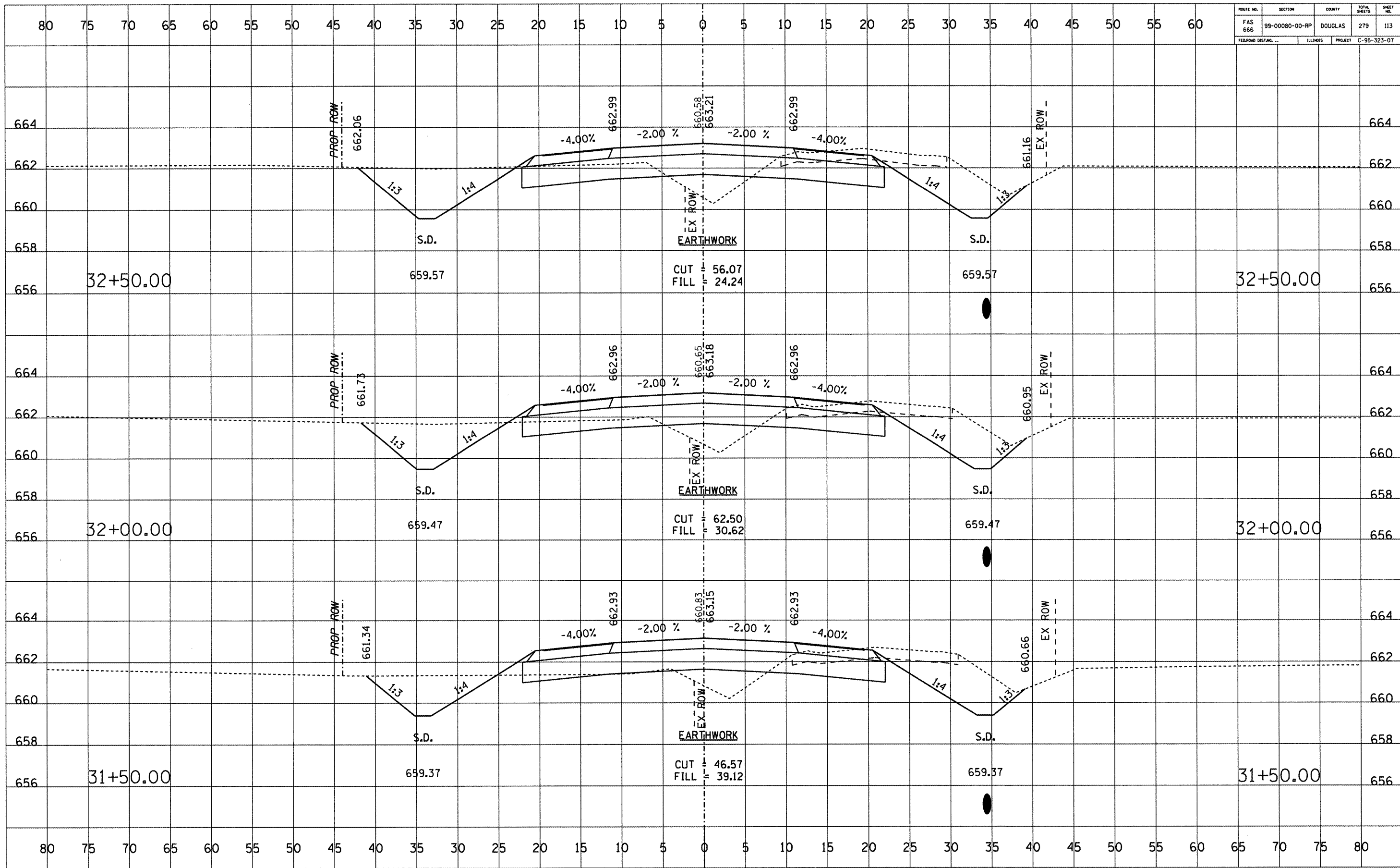

ROUTE NO.	SECTION	COUNTY	TOTAL SHEETS	SHEET NO.
FAS 666	99-00080-00-RP	DOUGLAS	279	114
FEDERAL DIST. NO.		ILLINOIS	PROJECT C-95-323-07	

DATE	
BY	
DESIGNED	
CHECKED	
APPROVED	
FINAL SURVEY	
NOTE BOOK NO.	

DATE	
BY	
DESIGNED	
CHECKED	
APPROVED	
ORIGINAL SURVEY	
NOTE BOOK NO.	

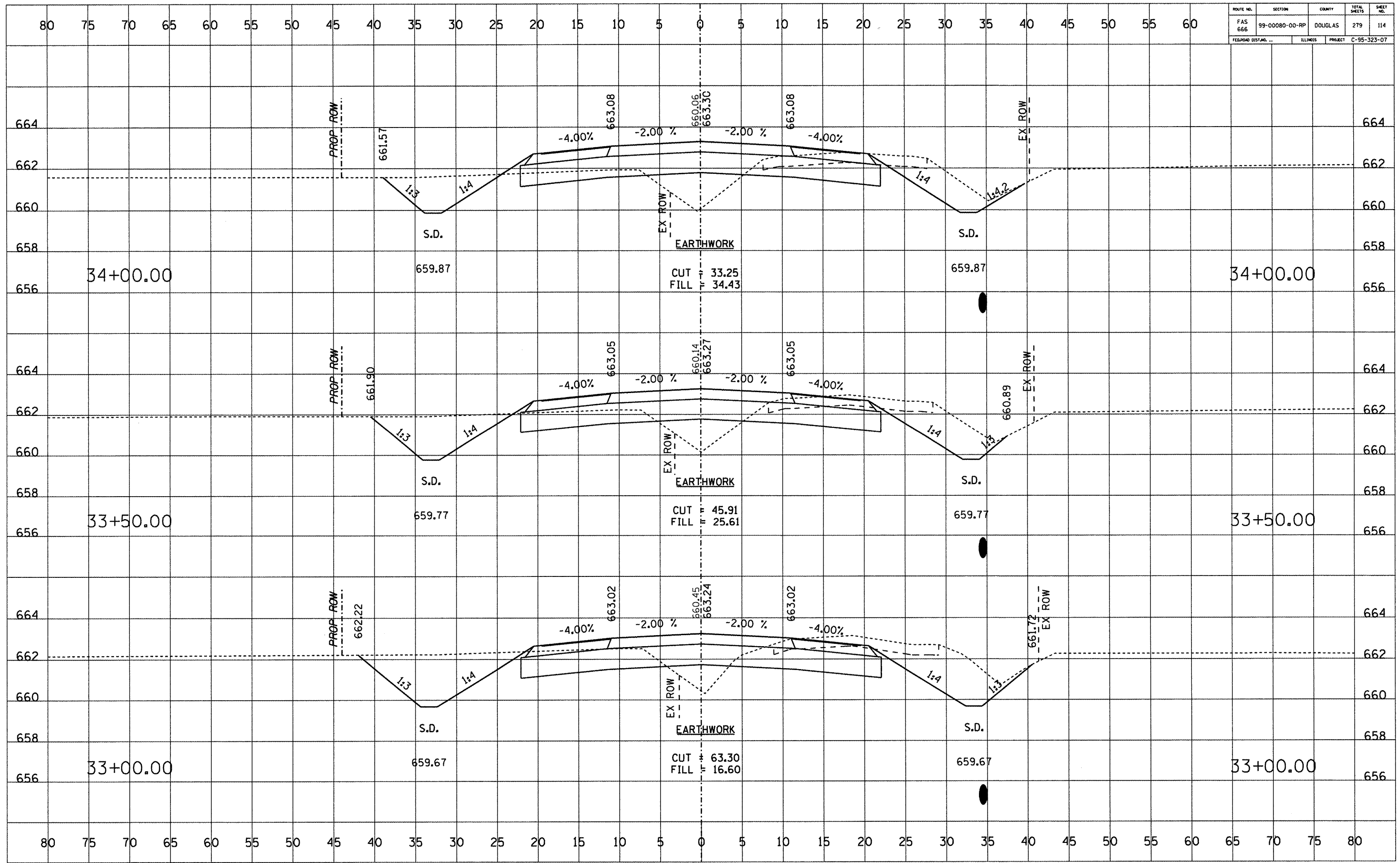

ROUTE NO.	SECTION	COUNTY	TOTAL SHEETS	SHEET NO.
FAS 666	99-00080-00-RP	DOUGLAS	279	115
FEEDROAD DISTANO. ...		ILLINOIS	PROJECT	C-95-323-07

DATE	BY

ORIGINAL SURVEY NO.	DATE	BY

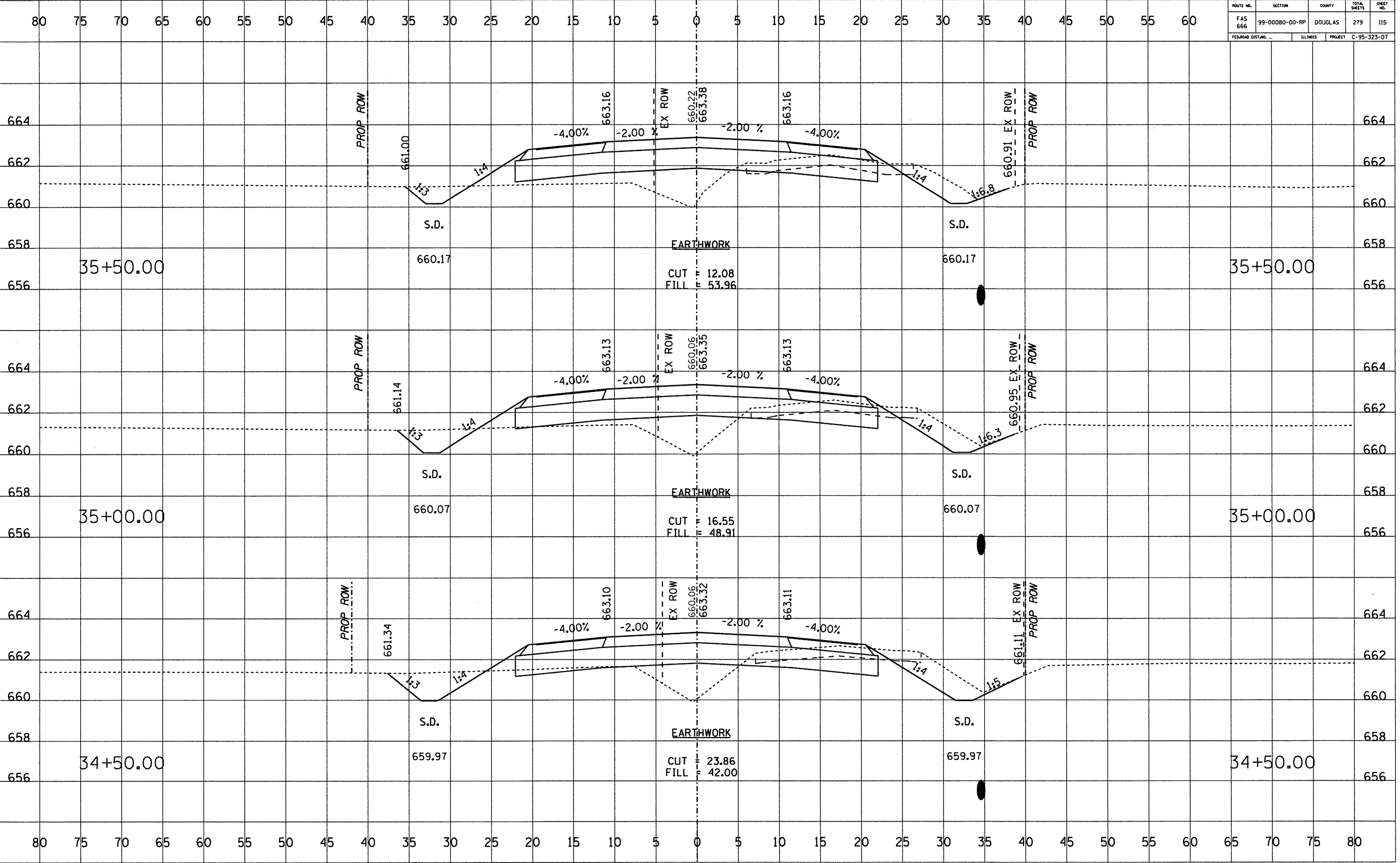

ROUTE NO.	SECTION	COUNTY	TOTAL SHEETS	SHEET NO.
FAS 666	99-00080-00-RP	DOUGLAS	279	116
FEDERAL DIST. NO.		ILLINOIS	PROJECT C-95-323-07	

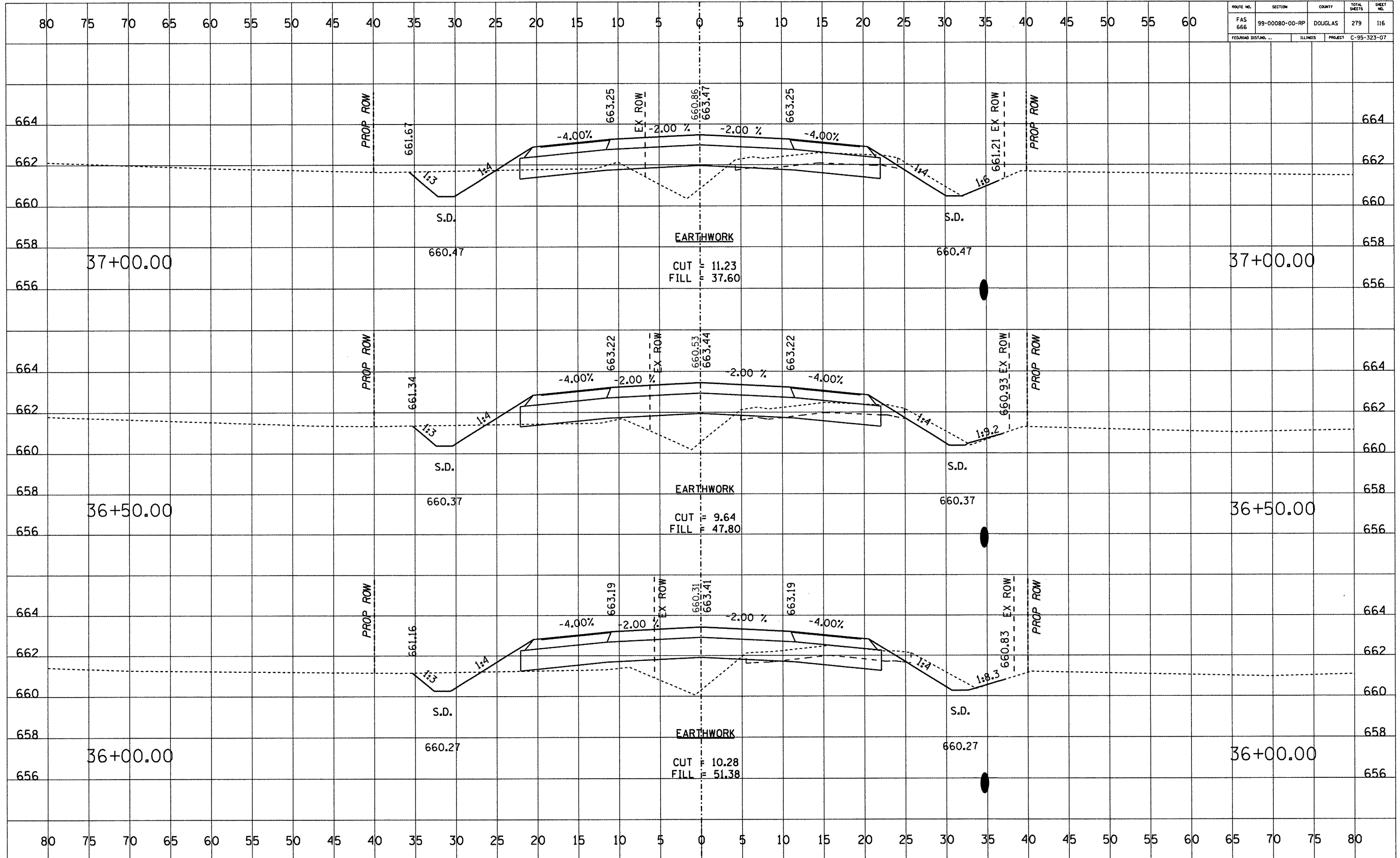

DATE	BY

DATE	BY



ROUTE NO.	SECTION	COUNTY	TOTAL SHEETS	SHEET NO.
FAS 666	99-00080-00-RP	DOUGLAS	279	117
FEDERAL DIST. NO.	ILLINOIS	PROJECT	C-95-323-07	

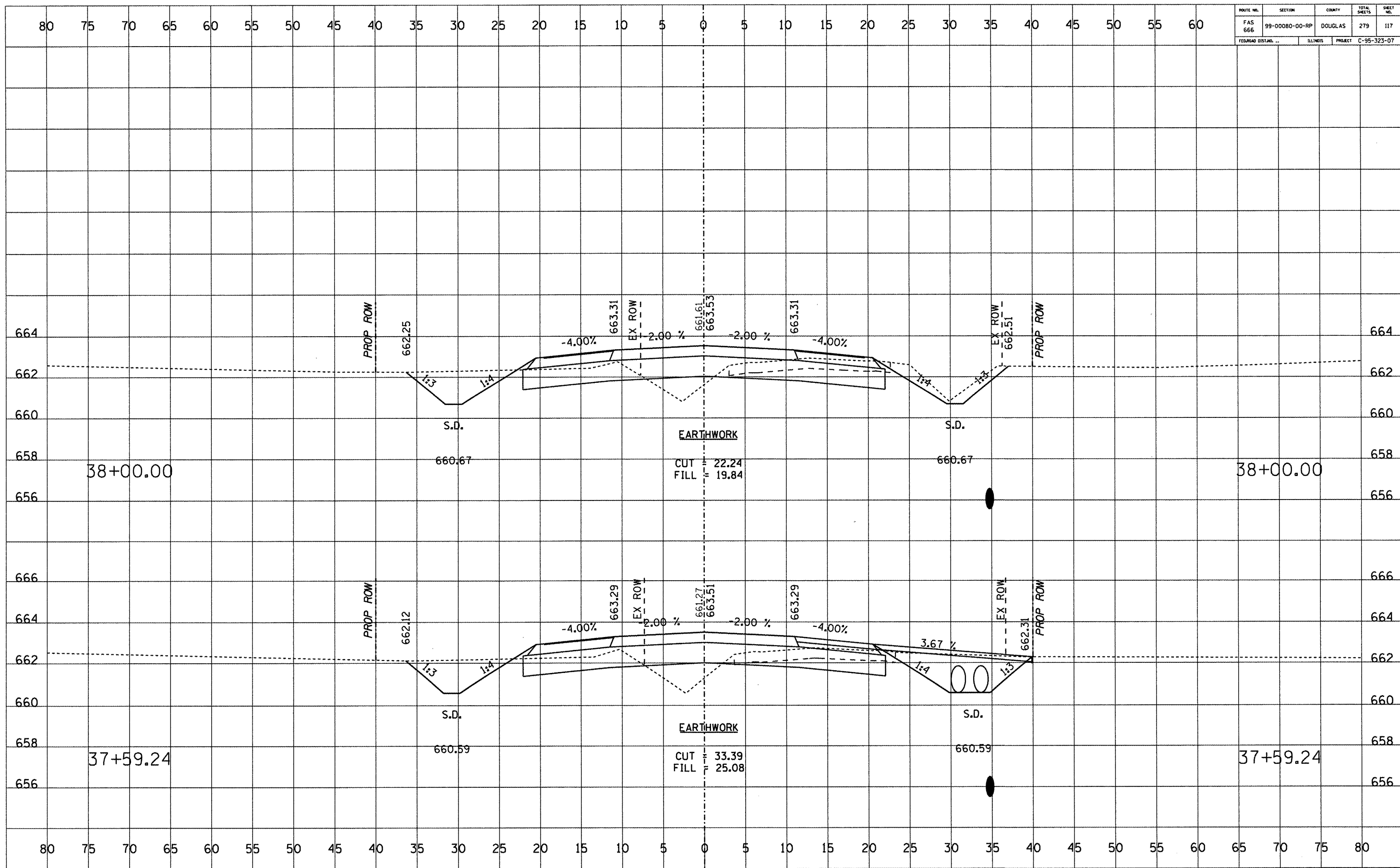

DATE	BY

FINAL SURVEY	SURVEYED	PLOTTED	TEMPLATE	AREAS CHECKED

DATE	BY

ORIGINAL SURVEY	SURVEYED	PLOTTED	TEMPLATE	AREAS CHECKED

ROUTE NO.	SECTION	COUNTY	TOTAL SHEETS	SHEET NO.
FAS 666	99-00080-00-RP	DOUGLAS	279	118
FEDERAL DIST. NO. ...		ILLINOIS	PROJECT	C-95-323-07

DATE	
BY	
FINAL SURVEY	
NOTED	
NO. ...	

DATE	
BY	
ORIGINAL SURVEY	
NOTED	
NO. ...	

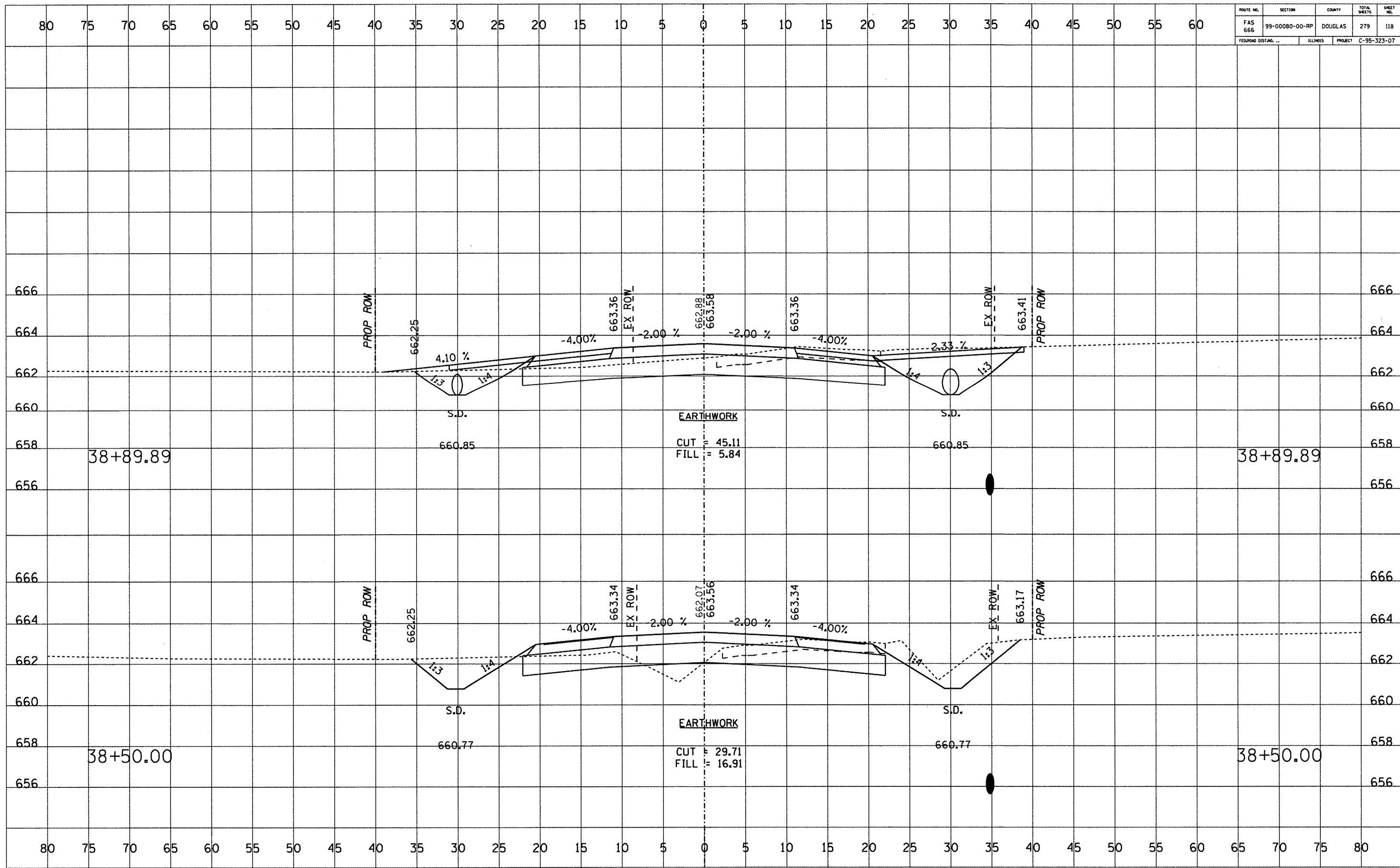

ROUTE NO.	SECTION	COUNTY	TOTAL SHEETS	SHEET NO.
FAS 666	99-00080-00-RP	DOUGLAS	279	119
FEDORAD DIST.NO.	ILLINOIS	PROJECT	C-95-323-07	

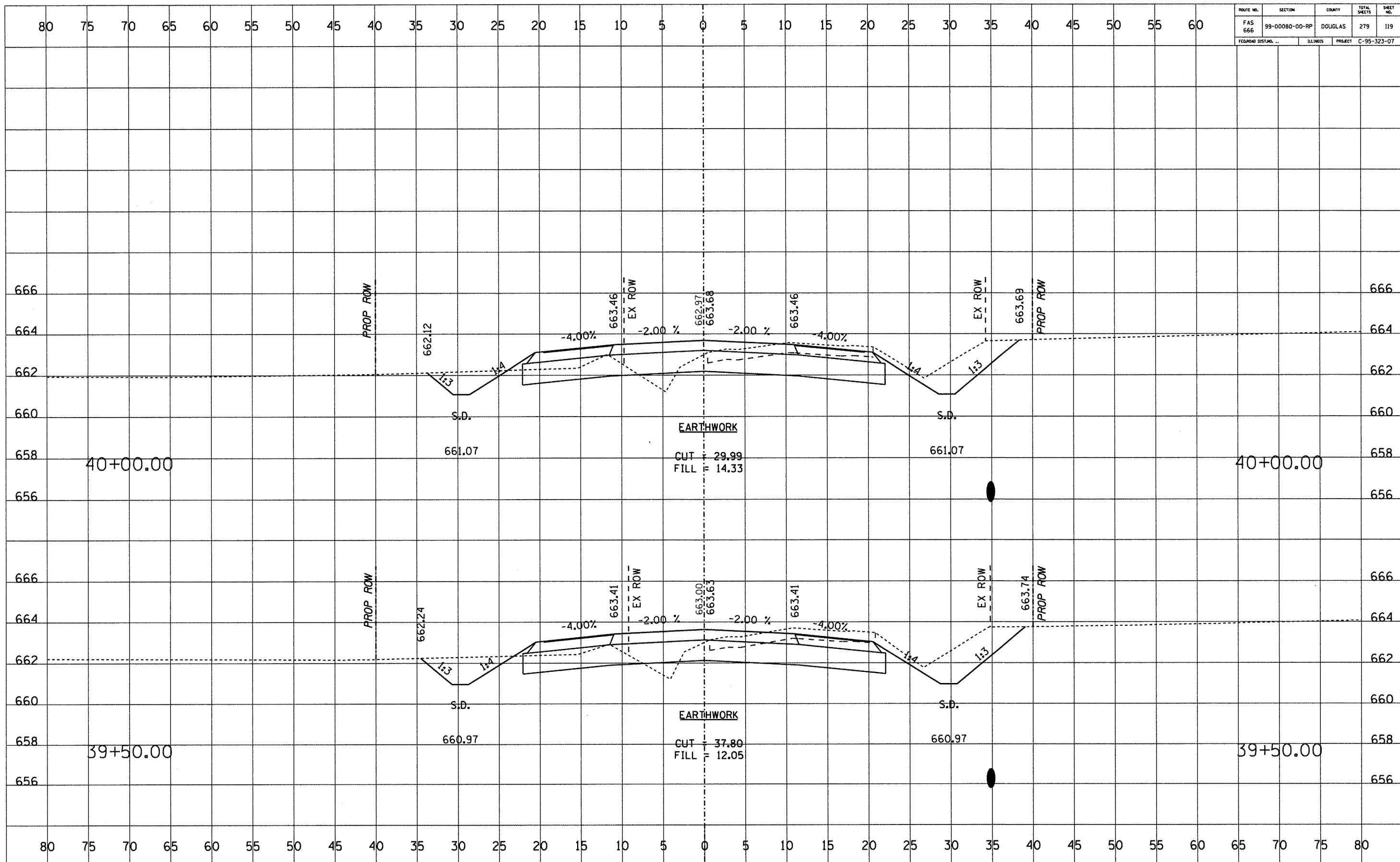

DATE	
BY	
NO.	
FINAL SURVEY	SURVEYED
NOTE BOOK	PLOTTED
NO.	REPLATE
	AREAS CHECKED

DATE	
BY	
NO.	
ORIGINAL SURVEY	SURVEYED
NOTE BOOK	PLOTTED
NO.	REPLATE
	AREAS CHECKED

40+00.00

40+00.00

39+50.00

39+50.00

EARTHWORK

CUT 29.99  
FILL 14.33

EARTHWORK

CUT 37.80  
FILL 12.05

ROUTE NO.	SECTION	COUNTY	TOTAL SHEETS	SHEET NO.
FAS 666	99-00080-00-RP	DOUGLAS	279	120
FEEDBACK DIST. ...		ILLINOIS	PROJECT	C-95-323-07

DATE	BY
DATE	BY
DATE	BY
DATE	BY
DATE	BY

DATE	BY
DATE	BY
DATE	BY
DATE	BY
DATE	BY

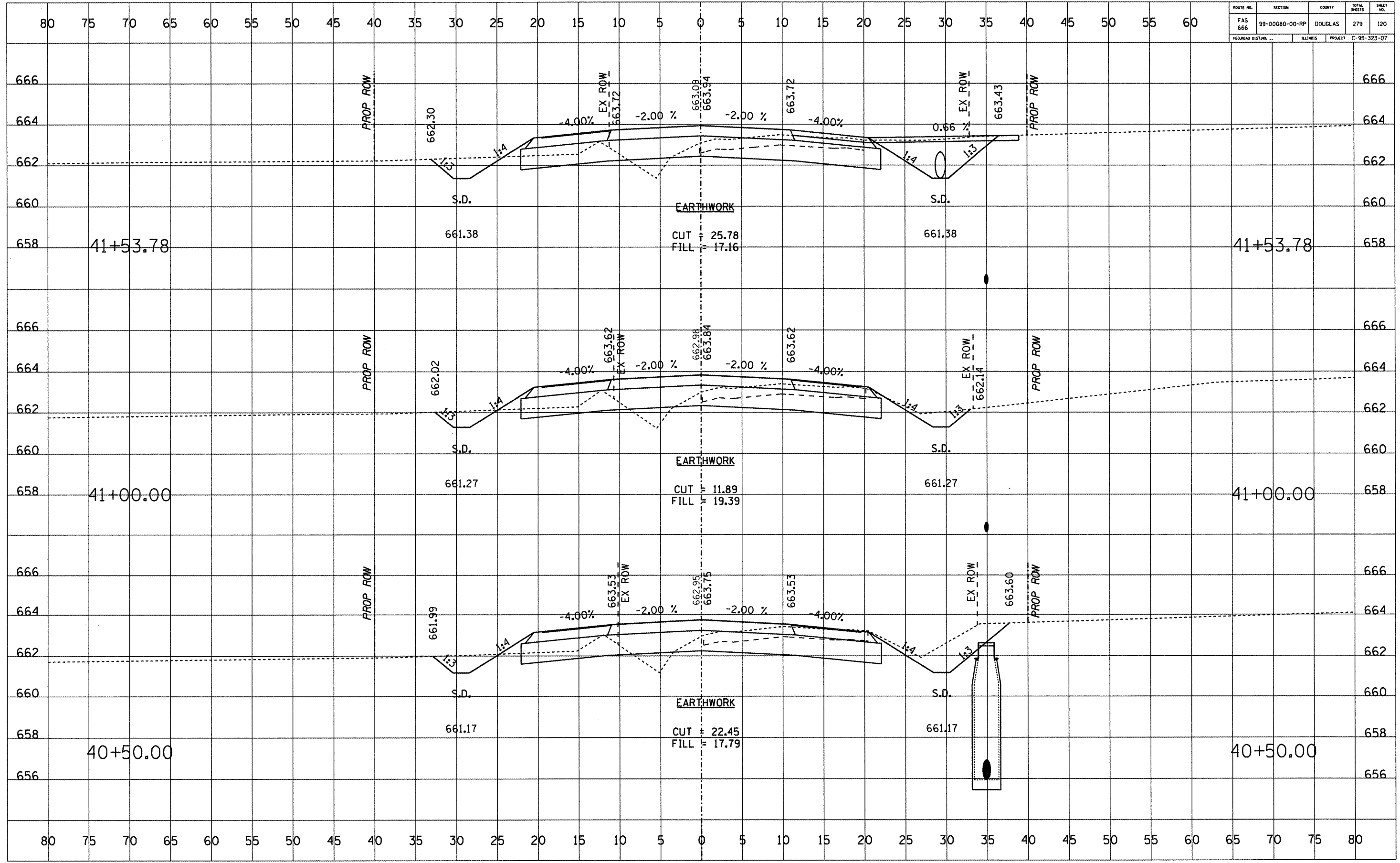

ROUTE NO.	SECTION	COUNTY	TOTAL SHEETS	SHEET NO.
FAS 666	99-00080-00-RP	DOUGLAS	279	121
FEDERAL DIST. NO.	ILLINOIS	PROJECT	C-95-323-07	

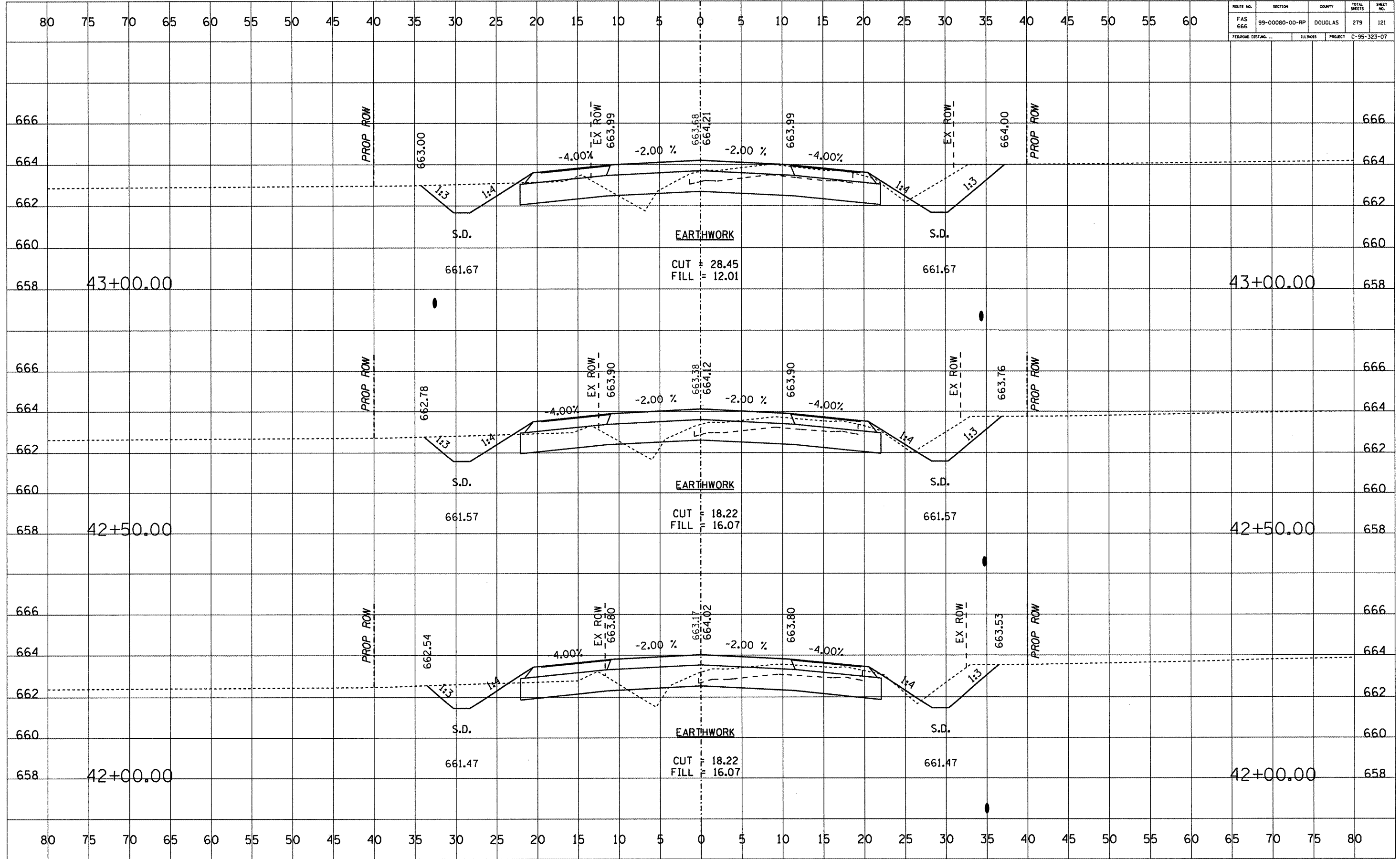

DATE	BY
FINAL SURVEY	SURVEYED
NOTE BOOK NO.	PLOTTED
	TEMPLATE
	AREAS CHECKED

DATE	BY
ORIGINAL SURVEY	SURVEYED
NOTE BOOK NO.	PLOTTED
	TEMPLATE
	AREAS CHECKED

ROUTE NO.	SECTION	COUNTY	TOTAL SHEETS	SHEET NO.
FAS 666	99-00080-00-RP	DOUGLAS	279	122
FEEDBACK DISTRICT	ILLINOIS	PROJECT	C-95-323-07	

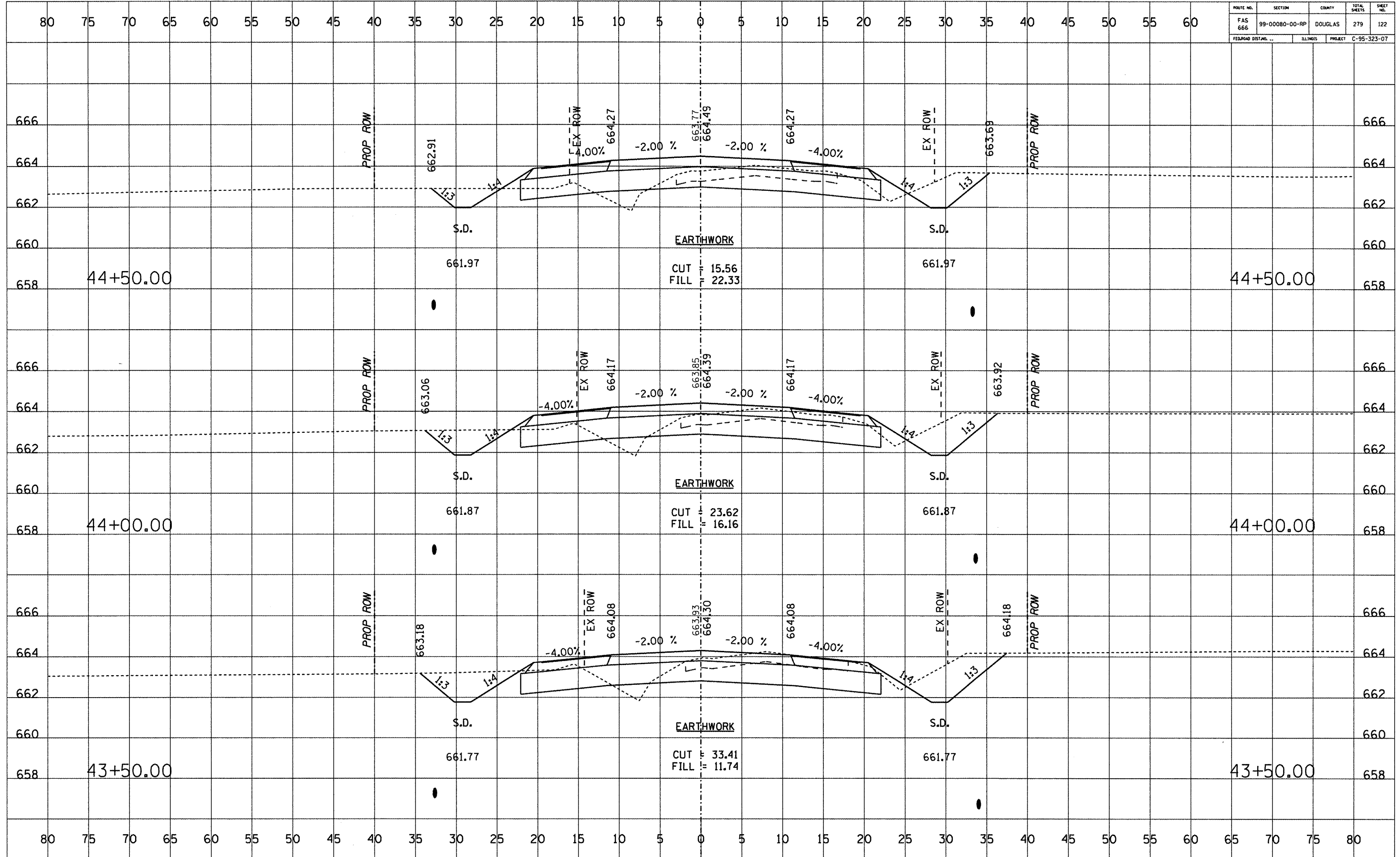

DATE	BY

DATE	BY

ROUTE NO.	SECTION	COUNTY	TOTAL SHEETS	SHEET NO.
FAS 666	99-00080-00-RP	DOUGLAS	279	123
FEDERAL DIST. NO. ...	ILLINOIS	PROJECT	C-95-323-07	

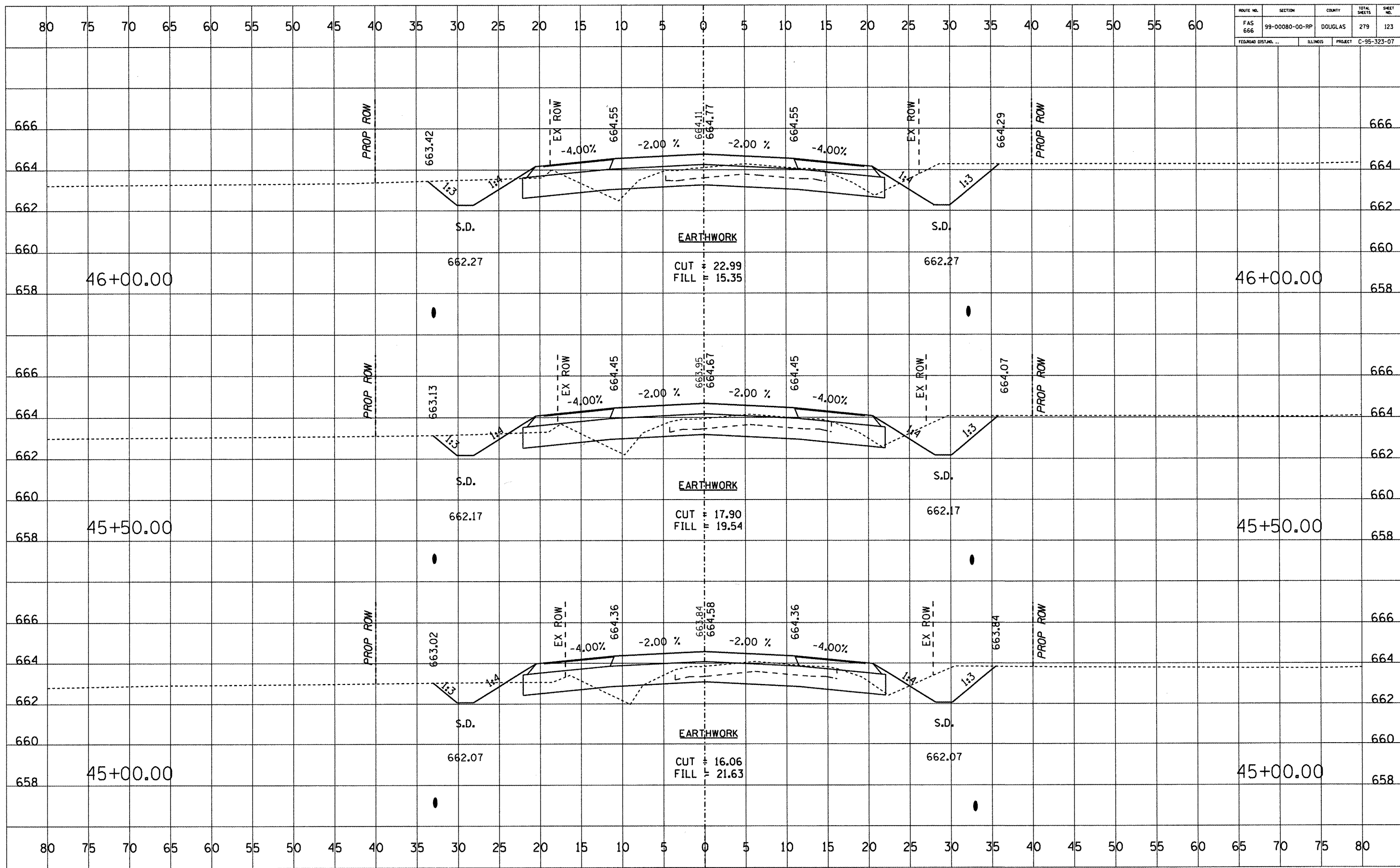

DATE	
BY	
FINAL SURVEY	
PLOTTED	
TEMPLATE	
NOTE BOOK	
AREAS CHECKED	
NO.	

DATE	
BY	
ORIGINAL SURVEY	
PLOTTED	
TEMPLATE	
NOTE BOOK	
AREAS CHECKED	
NO.	

ROUTE NO.	SECTION	COUNTY	TOTAL SHEETS	SHEET NO.
FAS 666	99-00080-00-RP	DOUGLAS	279	124
FEDERAL DIST. NO.	ILLINOIS	PROJECT	C-95-323-07	

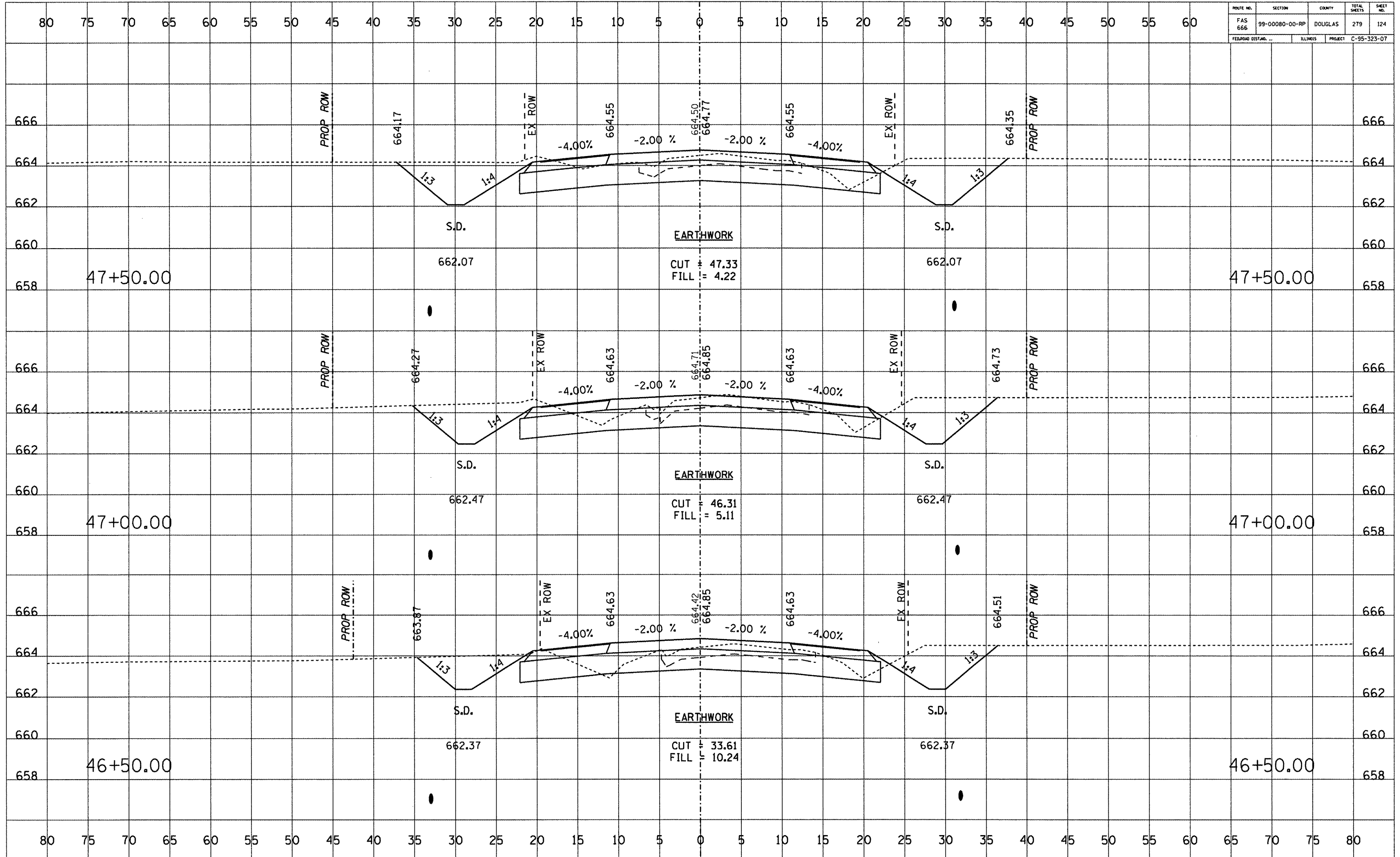

DATE	BY

DATE	BY

DATE	BY



ROUTE NO.	SECTION	COUNTY	TOTAL SHEETS	SHEET NO.
FAS 666	99-00080-00-RP	DOUGLAS	279	125
FEDERAL DIST. NO.		ILLINOIS	PROJECT C-95-323-07	

DATE	BY

DATE	BY

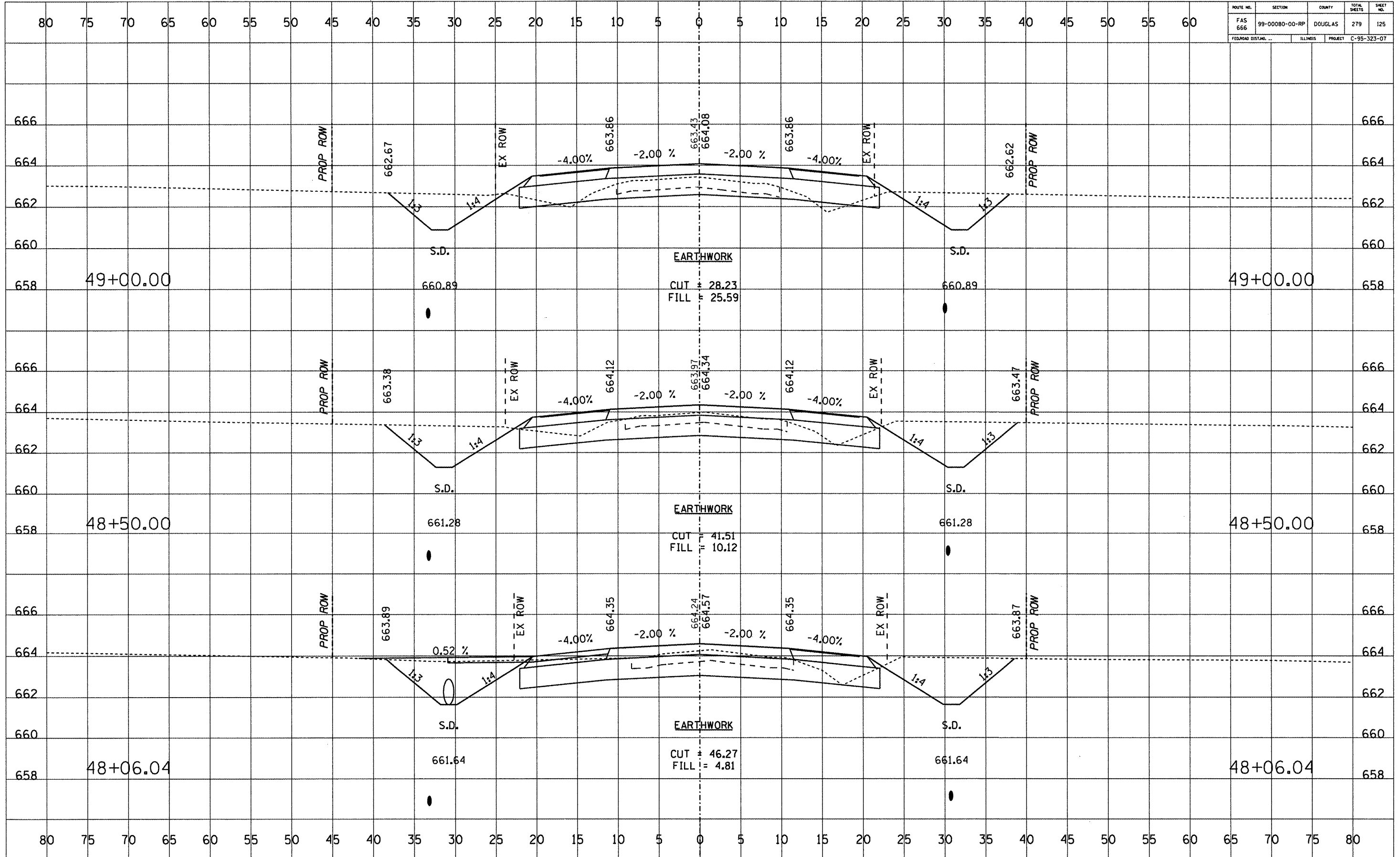

ROUTE NO.	SECTION	COUNTY	TOTAL SHEETS	SHEET NO.
FAS 666	99-00080-00-RP	DOUGLAS	279	126
FEDERAL DIST. NO. ...		ILLINOIS	PROJECT	C-95-323-07

DATE	BY

DATE	BY

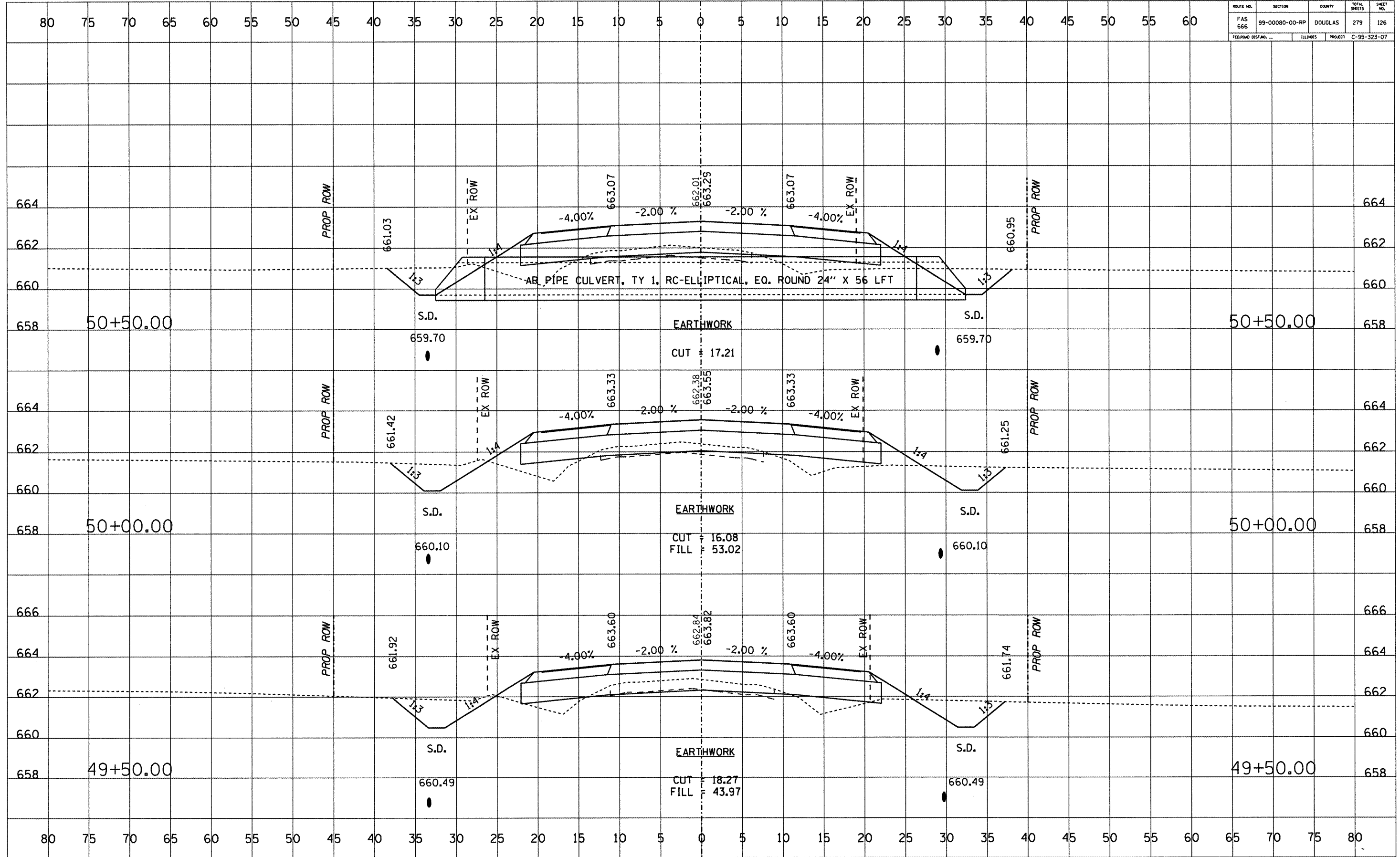

ROUTE NO.	SECTION	COUNTY	TOTAL SHEETS	SHEET NO.
FAS 666	99-00080-00-RP	DOUGLAS	279	127
FEDORAD DIST. NO. ...		ILLINOIS	PROJECT	C-95-323-07

DATE	BY
DATE	BY
DATE	BY
DATE	BY
DATE	BY

DATE	BY
DATE	BY
DATE	BY
DATE	BY
DATE	BY

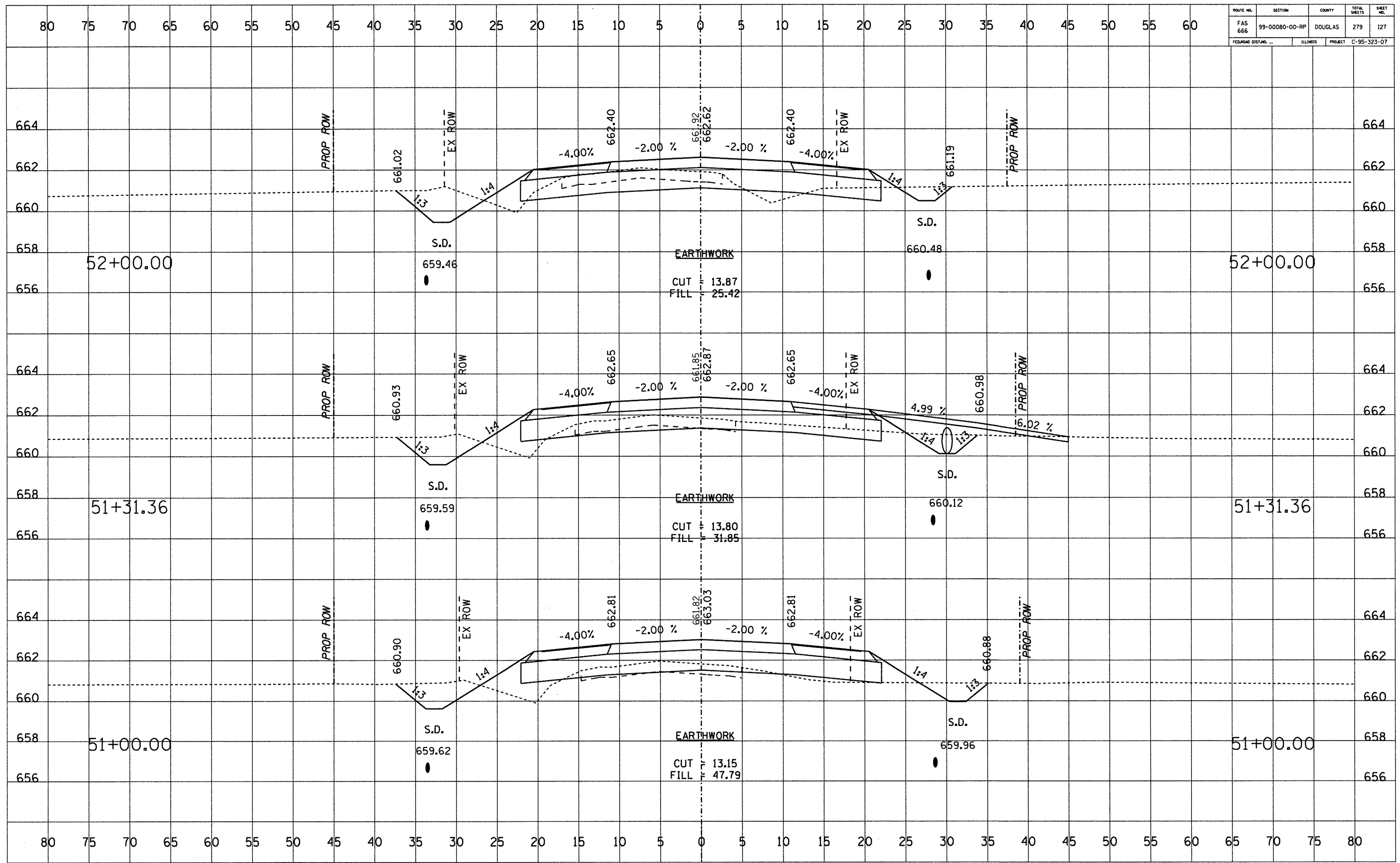

ROUTE NO.	SECTION	COUNTY	TOTAL SHEETS	SHEET NO.
FAS 666	99-00080-00-RP	DOUGLAS	279	128
FEDERAL DIST. NO.	ILLINOIS	PROJECT	C-95-323-07	

DATE	BY

DATE	BY

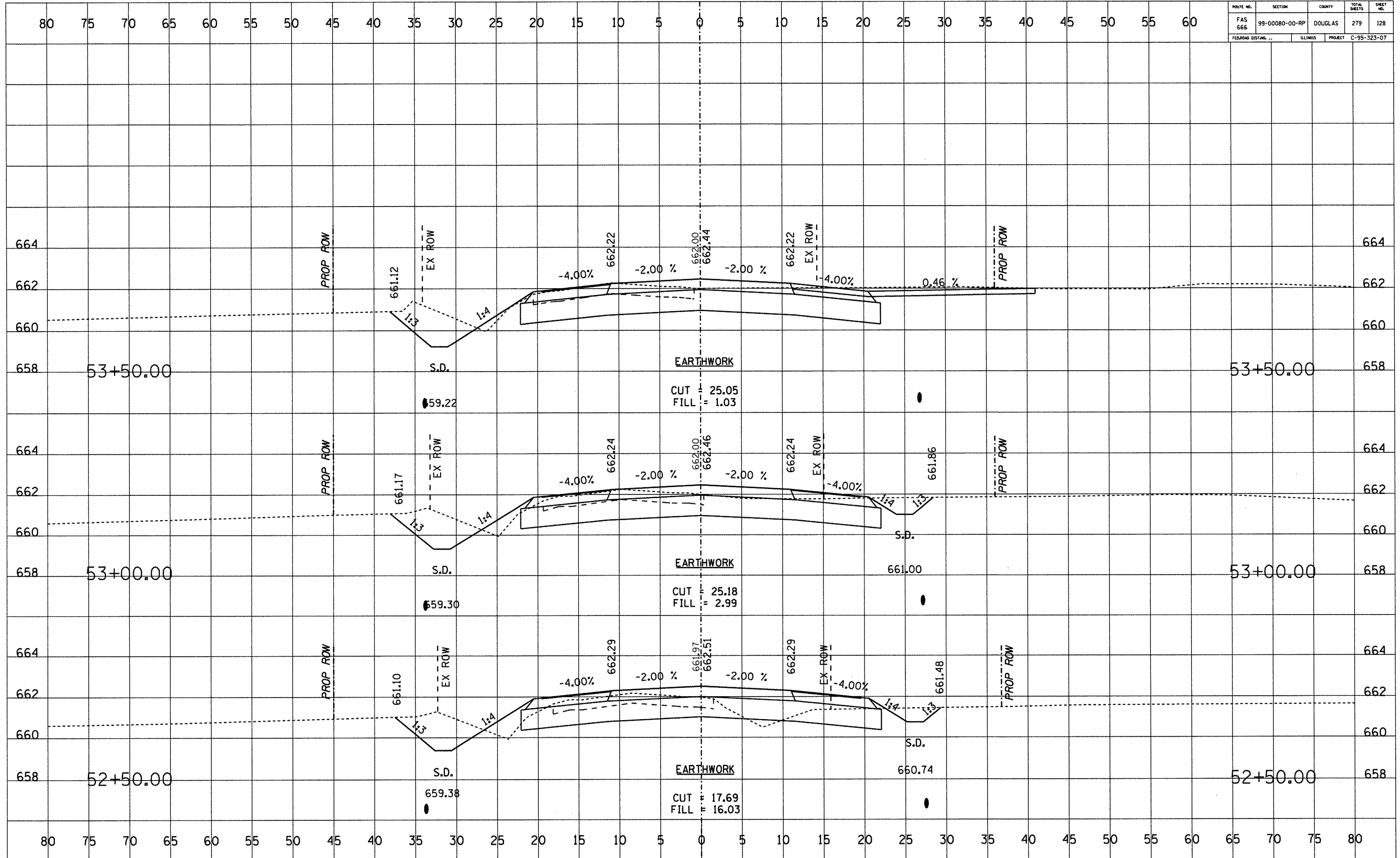

ROUTE NO.	SECTION	COUNTY	TOTAL SHEETS	SHEET NO.
FAS 666	99-00080-00-RP	DOUGLAS	279	129
FEDERAL DISTRICT		ILLINOIS	PROJECT C-95-323-07	

DATE	BY

DATE	BY

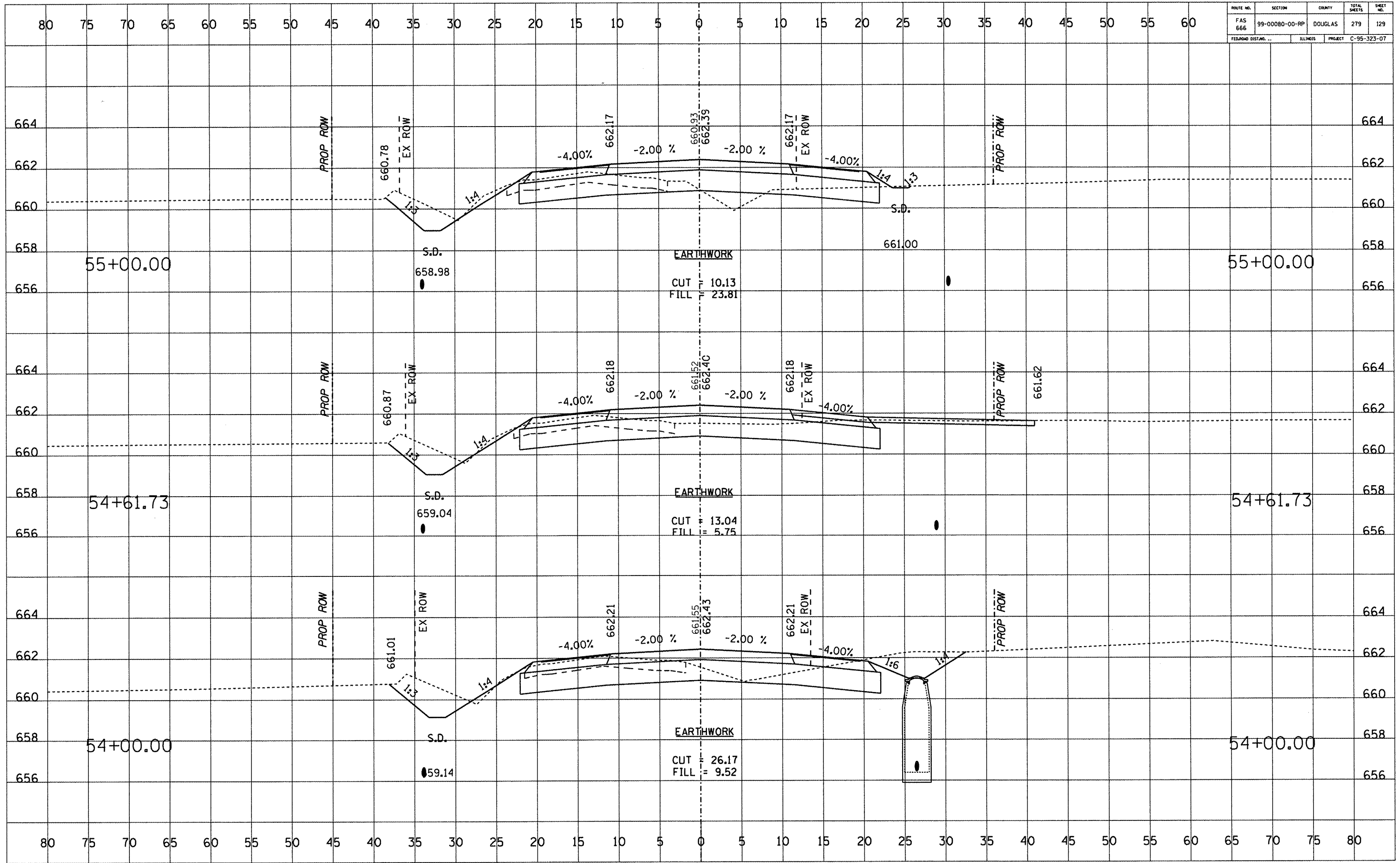

ROUTE NO.	SECTION	COUNTY	TOTAL SHEETS	SHEET NO.
FAS 666	99-00080-00-RP	DOUGLAS	279	130
FEDROAD DIST. NO.	ILLINOIS PROJECT	C-95-323-07		

DATE	BY

FINAL SURVEY	SURVEYED
NOTE BOOK NO.	PLOTTED
	TEMPLATE
	AREAS CHECKED

DATE	BY

ORIGINAL SURVEY	SURVEYED
NOTE BOOK NO.	PLOTTED
	TEMPLATE
	AREAS CHECKED

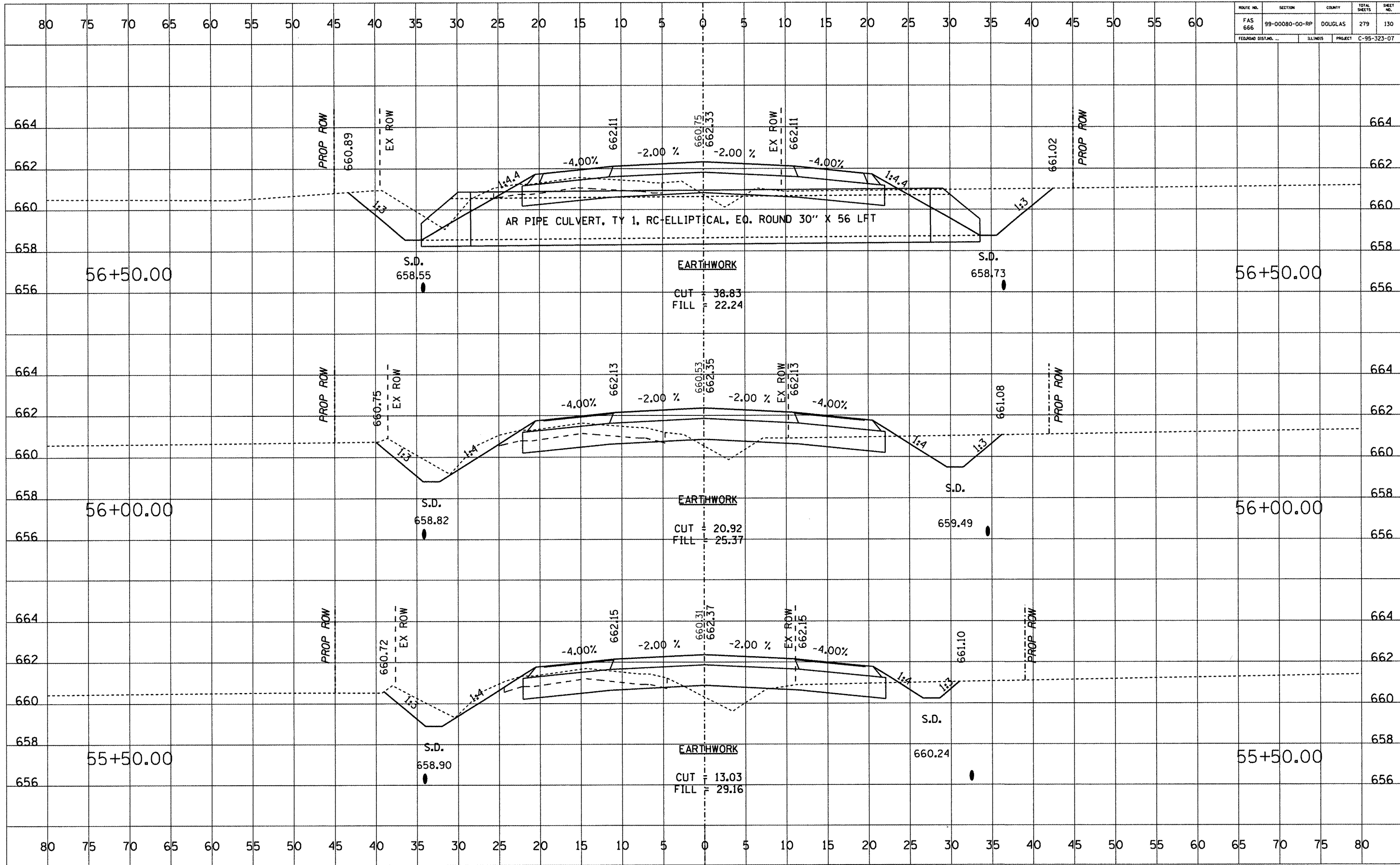

ROUTE NO.	SECTION	COUNTY	TOTAL SHEETS	SHEET NO.
FAS 666	99-00080-00-RP	DOUGLAS	279	131
FEDERAL DIST. NO.		ILLINOIS	PROJECT C-95-323-07	

DATE	BY

DATE	BY

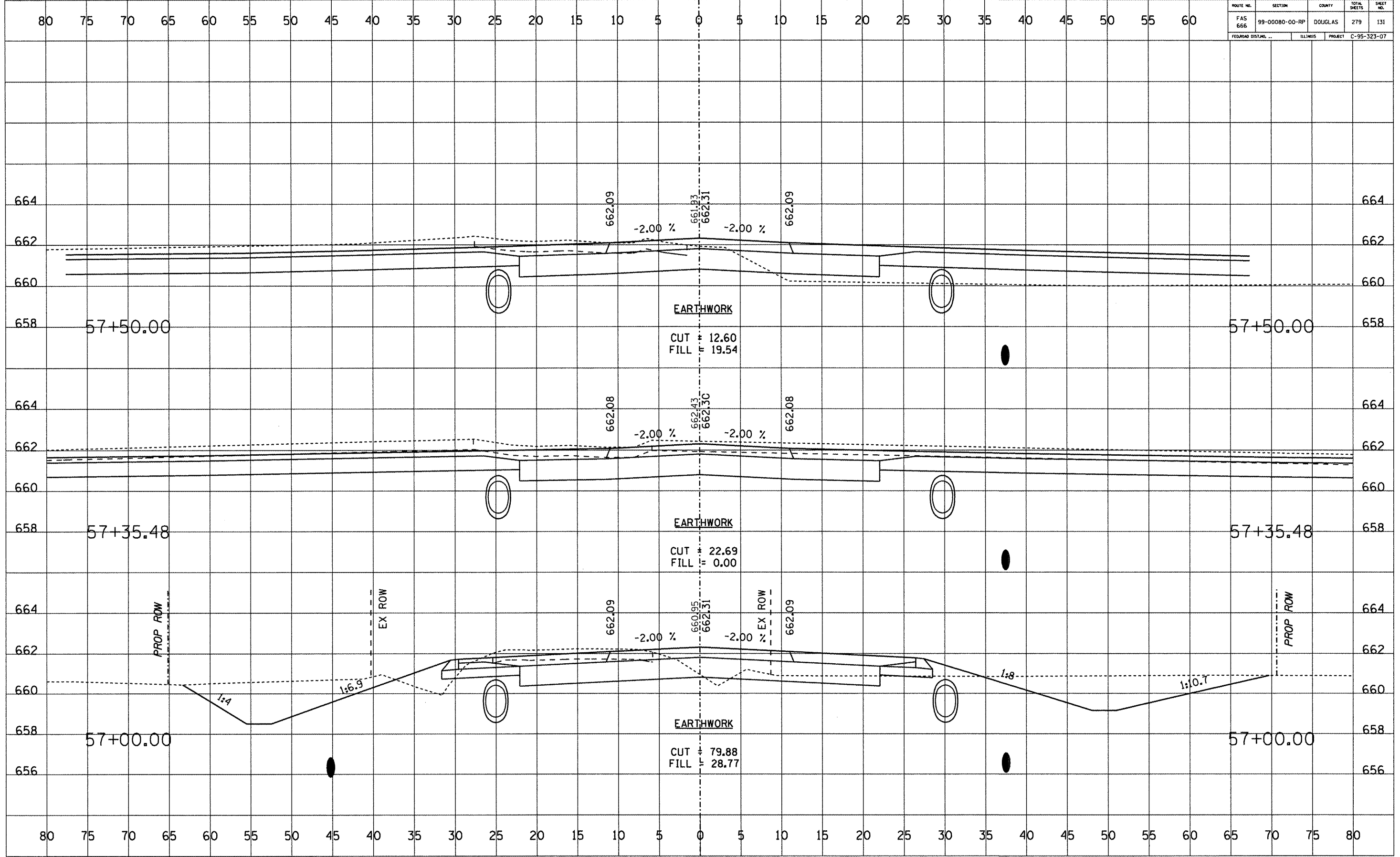

ROUTE NO.	SECTION	COUNTY	TOTAL SHEETS	SHEET NO.
FAS 666	99-0080-00-RP	DOUGLAS	279	132
FEDERAL DIST. NO. ...		ILLINOIS	PROJECT	C-95-323-07

DATE	BY

DATE	BY

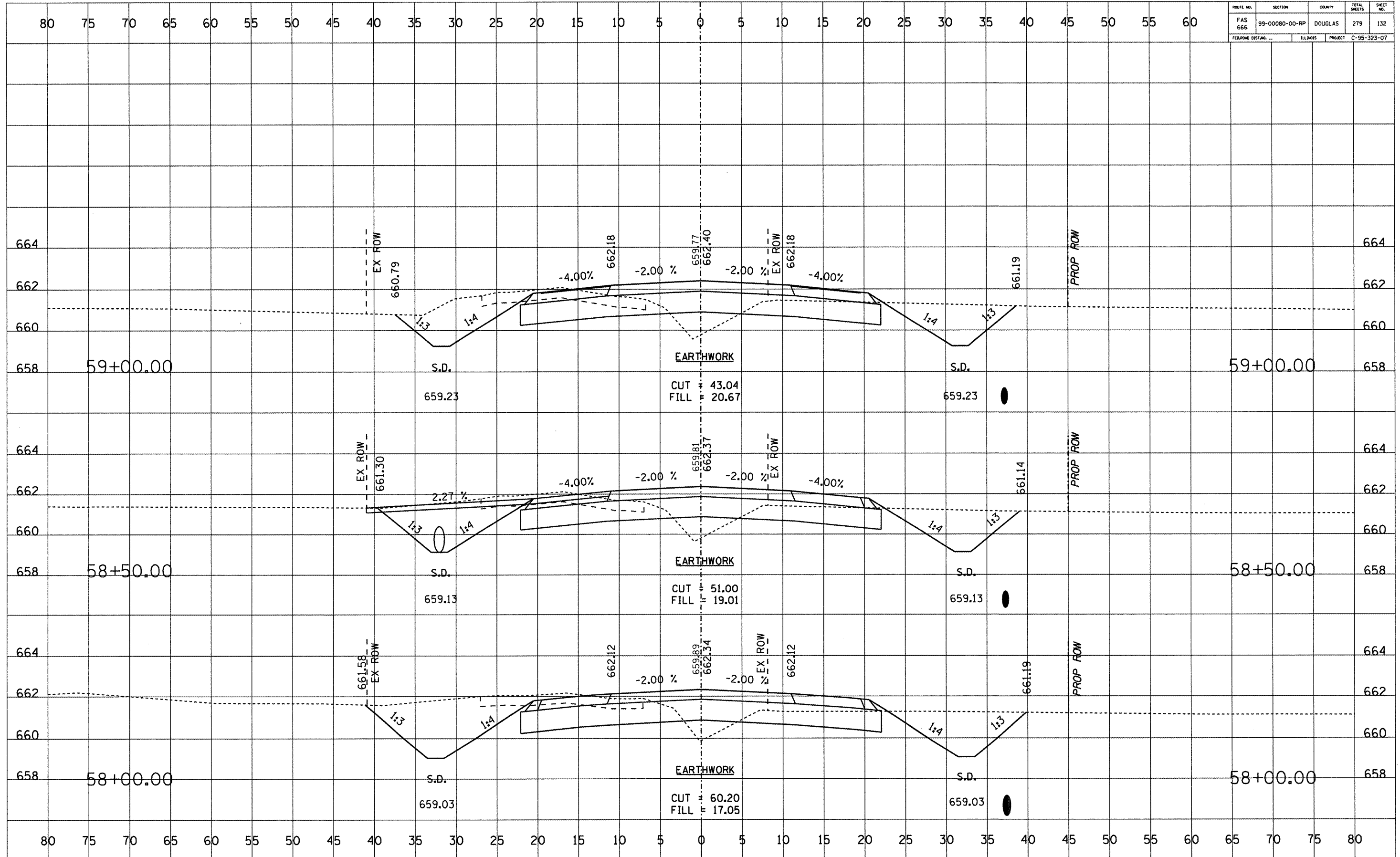



ROUTE NO.	SECTION	COUNTY	TOTAL SHEETS	SHEET NO.
FAS 666	99-00080-00-RP	DOUGLAS	279	133
FEDERAL DISTRICT		ILLINOIS	PROJECT C-95-323-07	

DATE	BY	NO.

DATE	BY	NO.

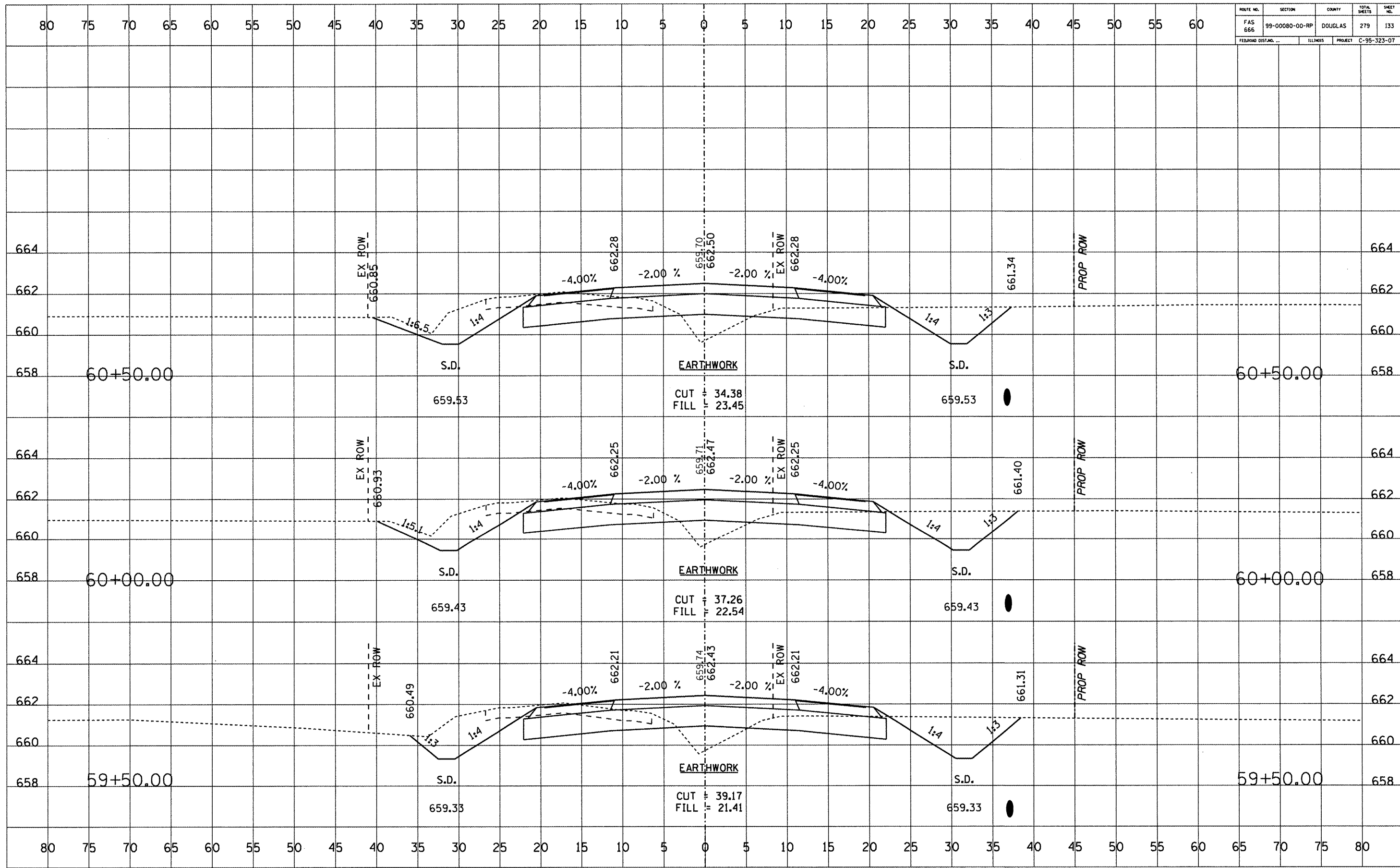

ROUTE NO.	SECTION	COUNTY	TOTAL SHEETS	SHEET NO.
FAS 666	99-00080-00-RP	DOUGLAS	279	134
FEDERAL DIST. NO. ...		ILLINOIS	PROJECT C-95-323-07	

DATE	
BY	
DESIGNED	
SURVEY	
PLOTTED	
TEMPLATE	
NOTE BOOK	
NO.	
AREAS CHECKED	

DATE	
BY	
DESIGNED	
SURVEY	
PLOTTED	
TEMPLATE	
NOTE BOOK	
NO.	
AREAS CHECKED	

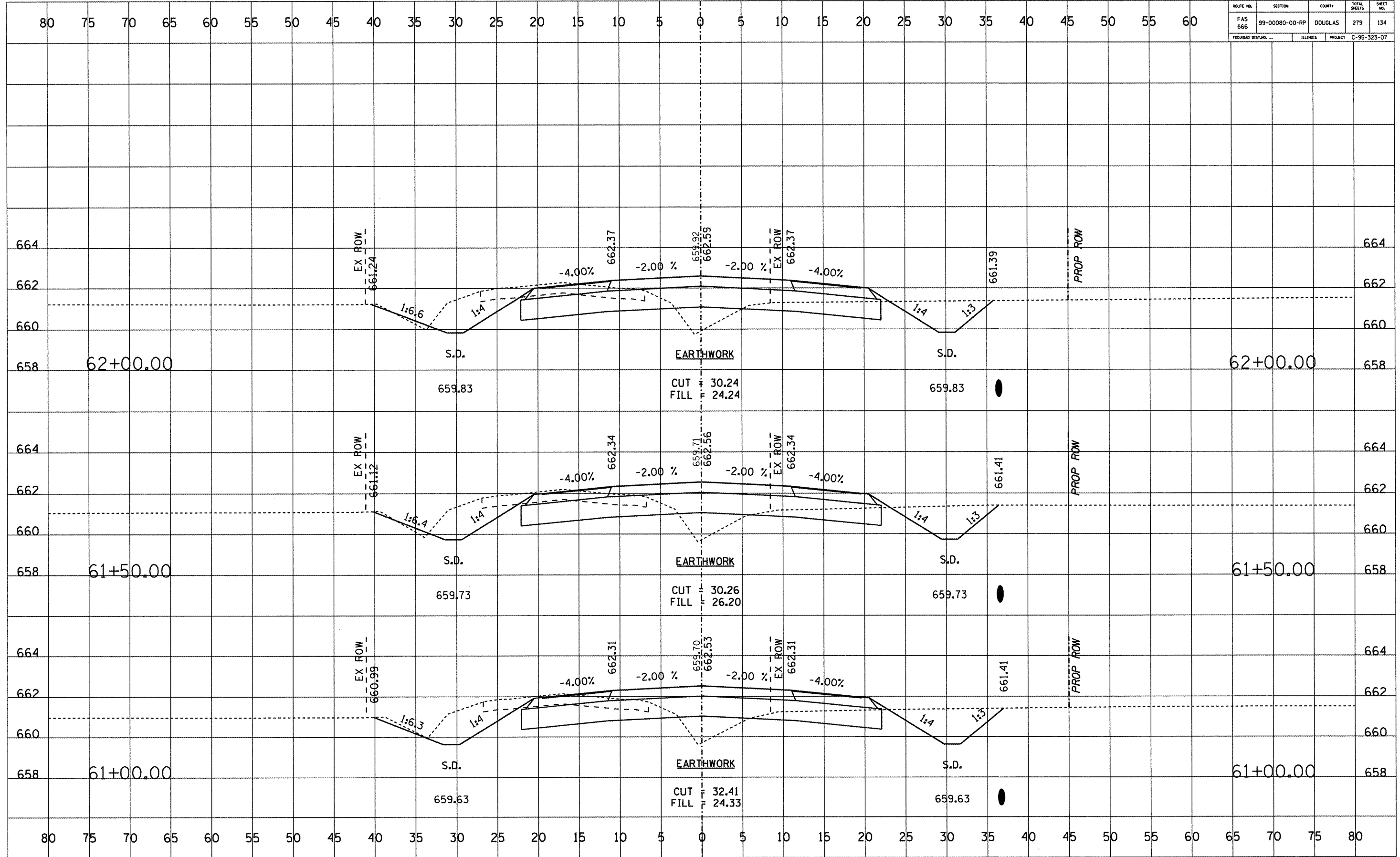

ROUTE NO.	SECTION	COUNTY	TOTAL SHEETS	SHEET NO.
FAS 666	99-00080-00-RP	DOUGLAS	279	135
FEDERAL DIST. NO. ...		ILLINOIS	PROJECT C-95-323-07	

DATE	BY

DATE	BY

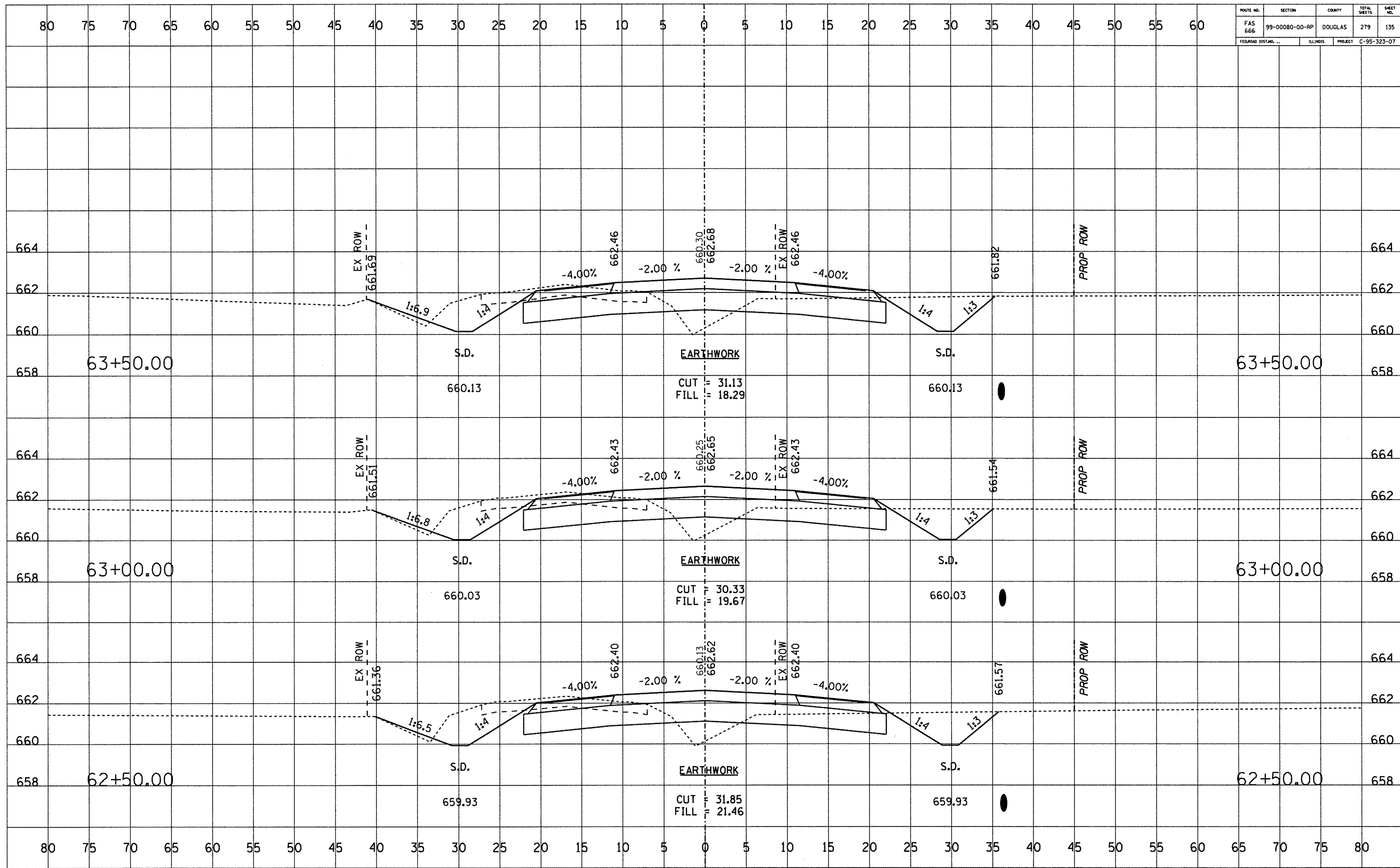

ROUTE NO.	SECTION	COUNTY	TOTAL SHEETS	SHEET NO.
FAS 666	99-00080-00-RP	DOUGLAS	279	136
FEDERAL DIST. NO. ...		ILLINOIS	PROJECT C-95-323-07	

DATE	
BY	
FINAL SURVEY	
PLOTTED	
NOTE BOOK	
AREAS CHECKED	
NO.	

DATE	
BY	
ORIGINAL SURVEY	
PLOTTED	
NOTE BOOK	
AREAS CHECKED	
NO.	

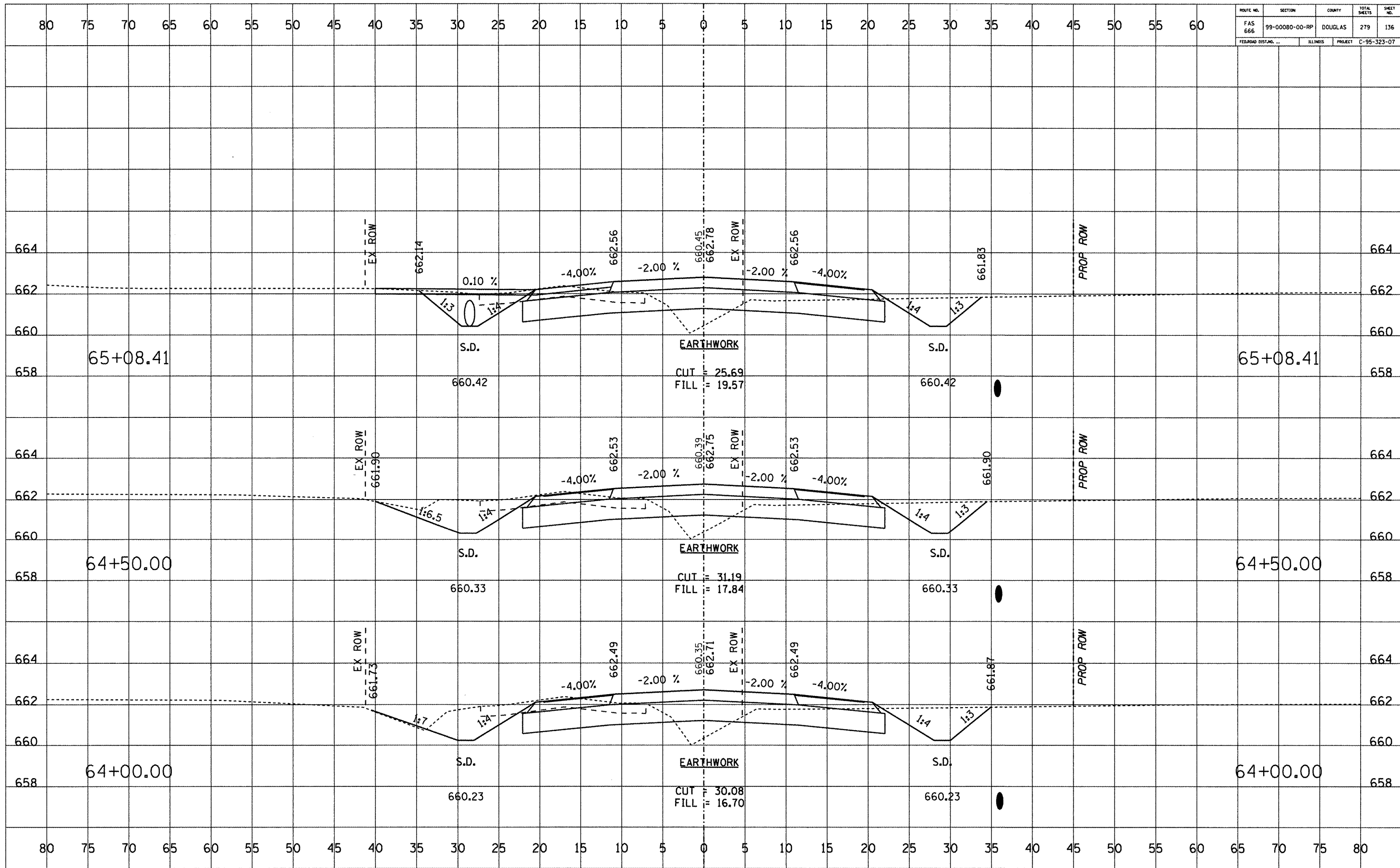

ROUTE NO.	SECTION	COUNTY	TOTAL SHEETS	SHEET NO.
FAS 666	99-00080-00-RP	DOUGLAS	279	137
FEDERAL DIST. NO.		ILLINOIS	PROJECT	C-95-323-07

DATE	BY

  

FINAL SURVEY	SURVEYED	PLOTTED	DATE
NOTE BOOK NO.		AREAS CHECKED	

DATE	BY

ORIGINAL SURVEY	SURVEYED	PLOTTED	DATE
NOTE BOOK NO.		AREAS CHECKED	

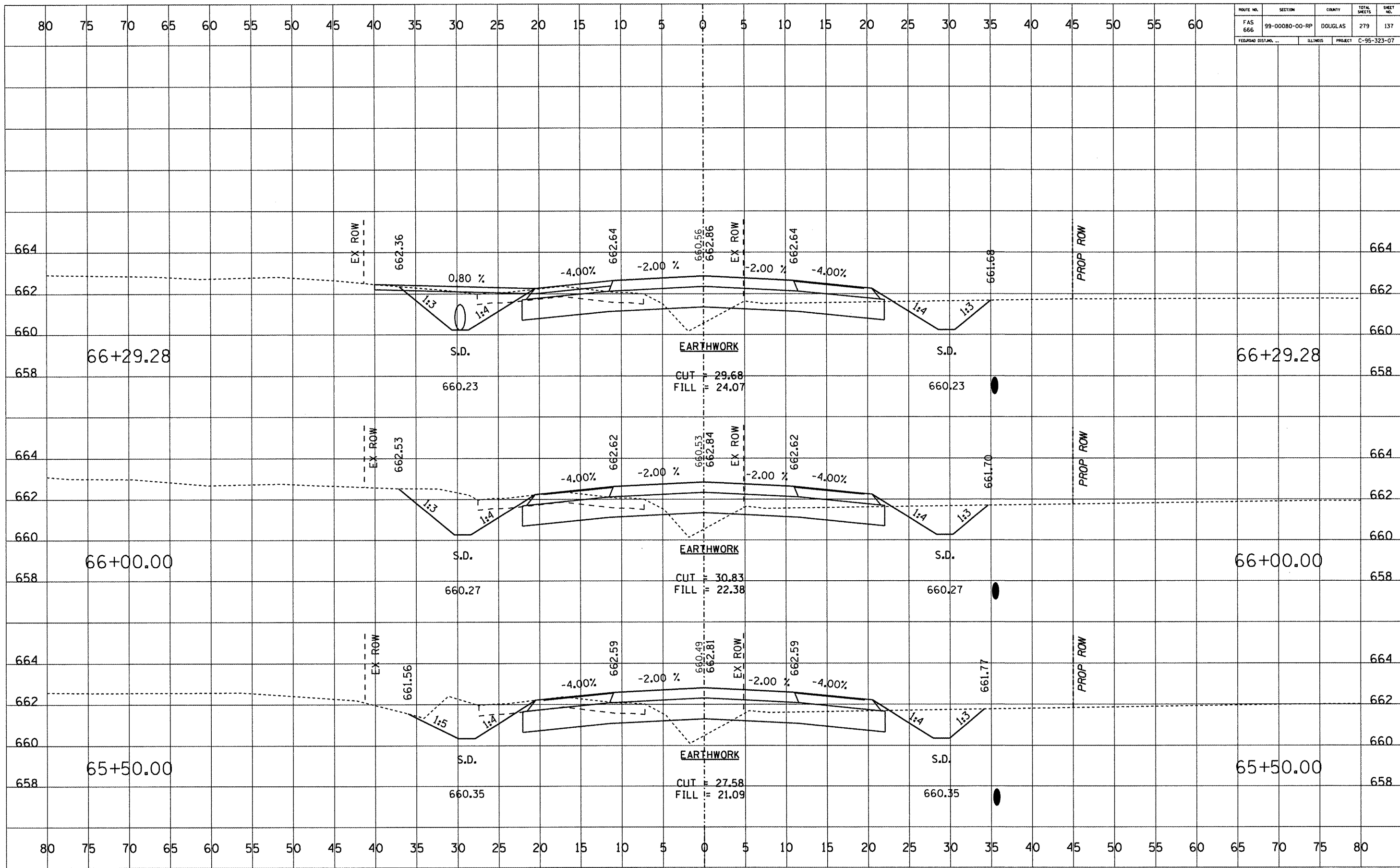

ROUTE NO.	SECTION	COUNTY	TOTAL SHEETS	SHEET NO.
FAS 666	99-00080-00-RP	DOUGLAS	279	138
FEDERAL DIST. NO. ...		ILLINOIS	PROJECT C-95-323-07	

DATE	BY

DATE	BY

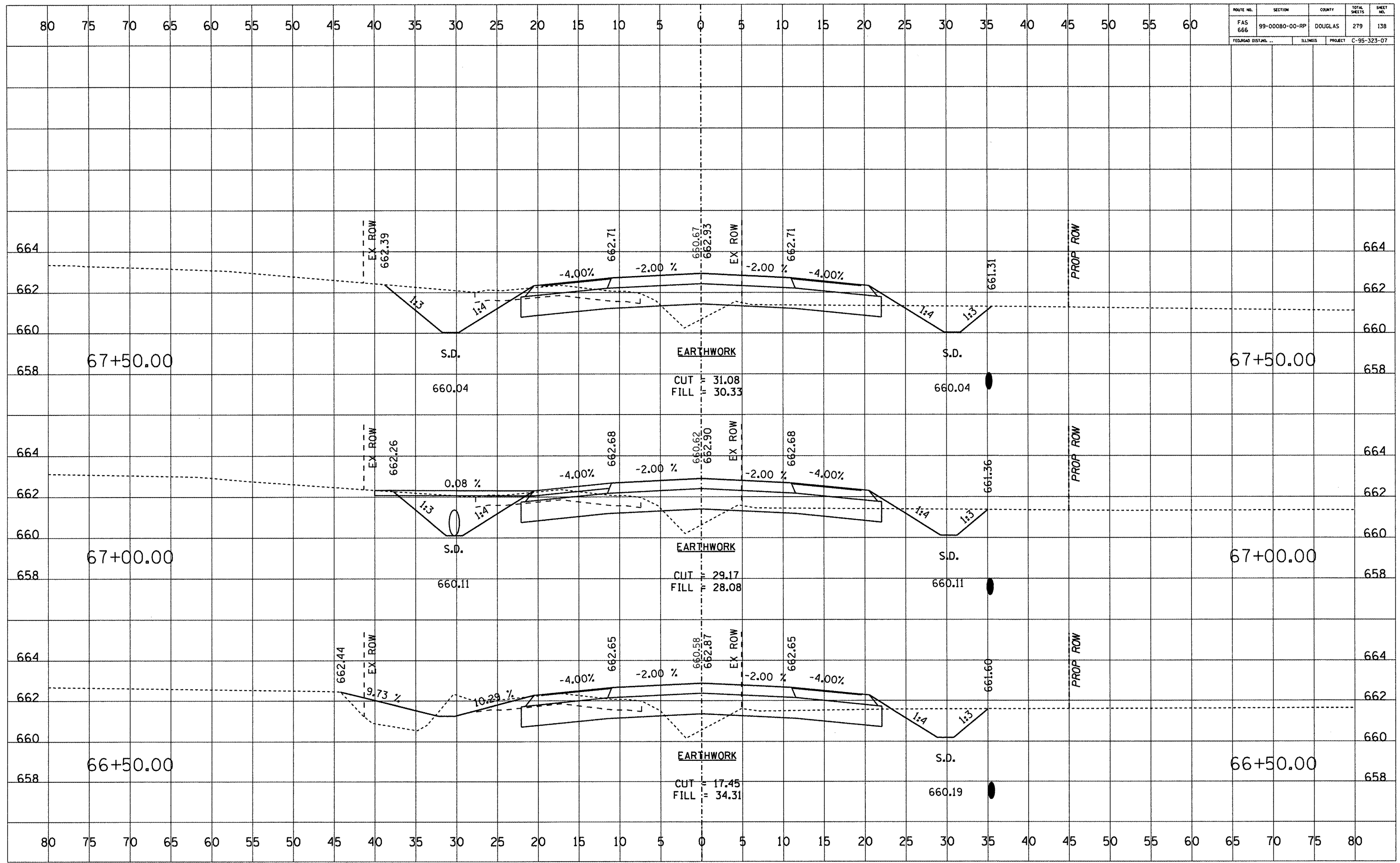

ROUTE NO. FAS 666	SECTION 99-00080-00-RP	COUNTY DOUGLAS	TOTAL SHEETS 279	SHEET NO. 139
FEDERAL DIST. NO. ...		ILLINOIS	PROJECT C-95-323-07	

DATE	
BY	
REVISIONS	
NO.	
DATE	
BY	
REVISIONS	
NO.	
DATE	
BY	
REVISIONS	
NO.	
DATE	
BY	
REVISIONS	
NO.	
DATE	
BY	
REVISIONS	
NO.	
DATE	
BY	
REVISIONS	
NO.	

DATE	
BY	
REVISIONS	
NO.	
DATE	
BY	
REVISIONS	
NO.	
DATE	
BY	
REVISIONS	
NO.	
DATE	
BY	
REVISIONS	
NO.	
DATE	
BY	
REVISIONS	
NO.	
DATE	
BY	
REVISIONS	
NO.	

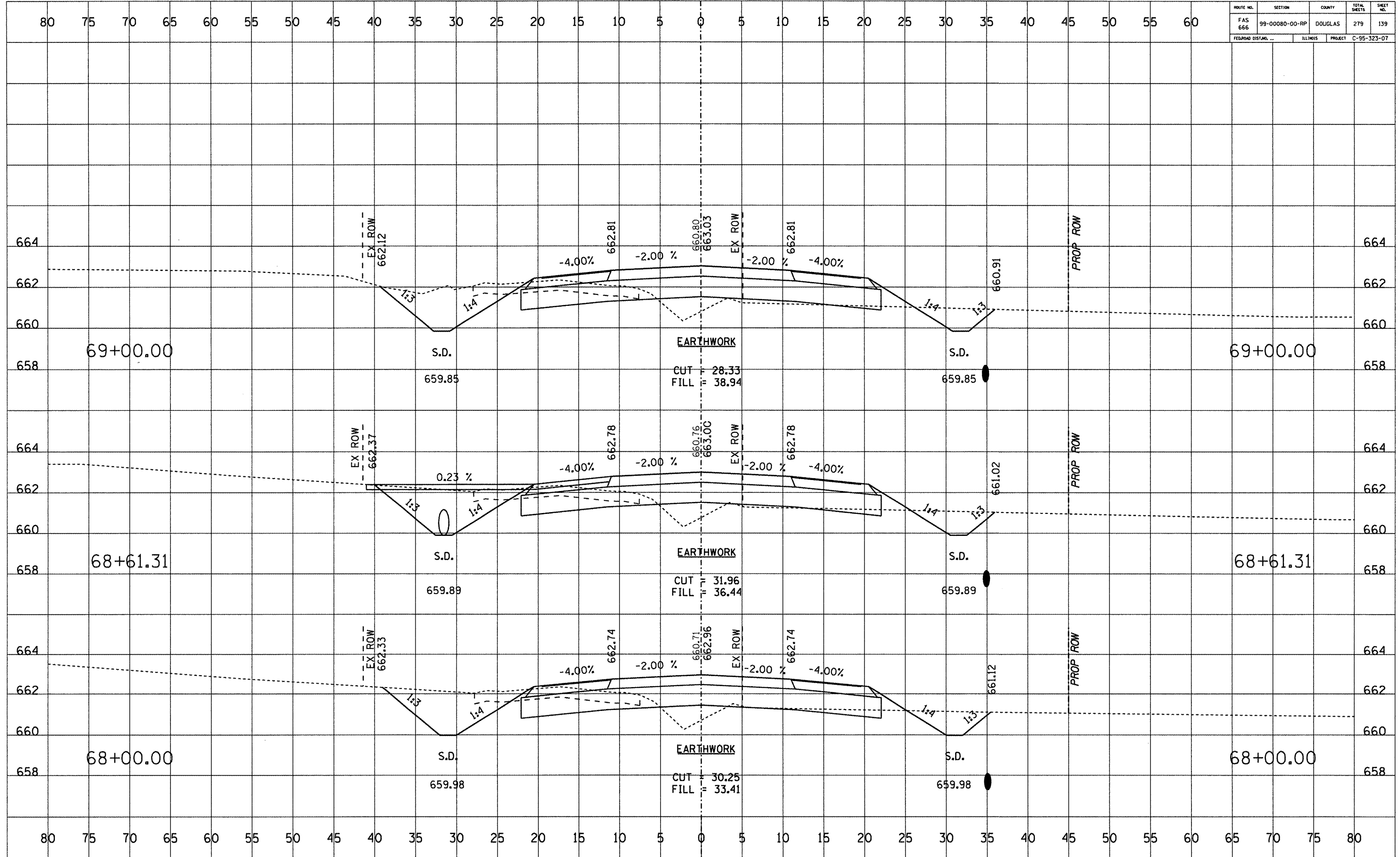

ROUTE NO.	SECTION	COUNTY	TOTAL SHEETS	SHEET NO.
FAS 666	99-00080-00-RP	DOUGLAS	279	140
FEDERAL DIST. NO. ...		ILLINOIS	PROJECT C-95-323-07	

DATE	BY
FINAL SURVEY	CHECKED
NOTE BOOK	PLOTTED
NO.	TEMPLATE
	AREAS CHECKED

DATE	BY
ORIGINAL SURVEY	CHECKED
NOTE BOOK	PLOTTED
NO.	TEMPLATE
	AREAS CHECKED

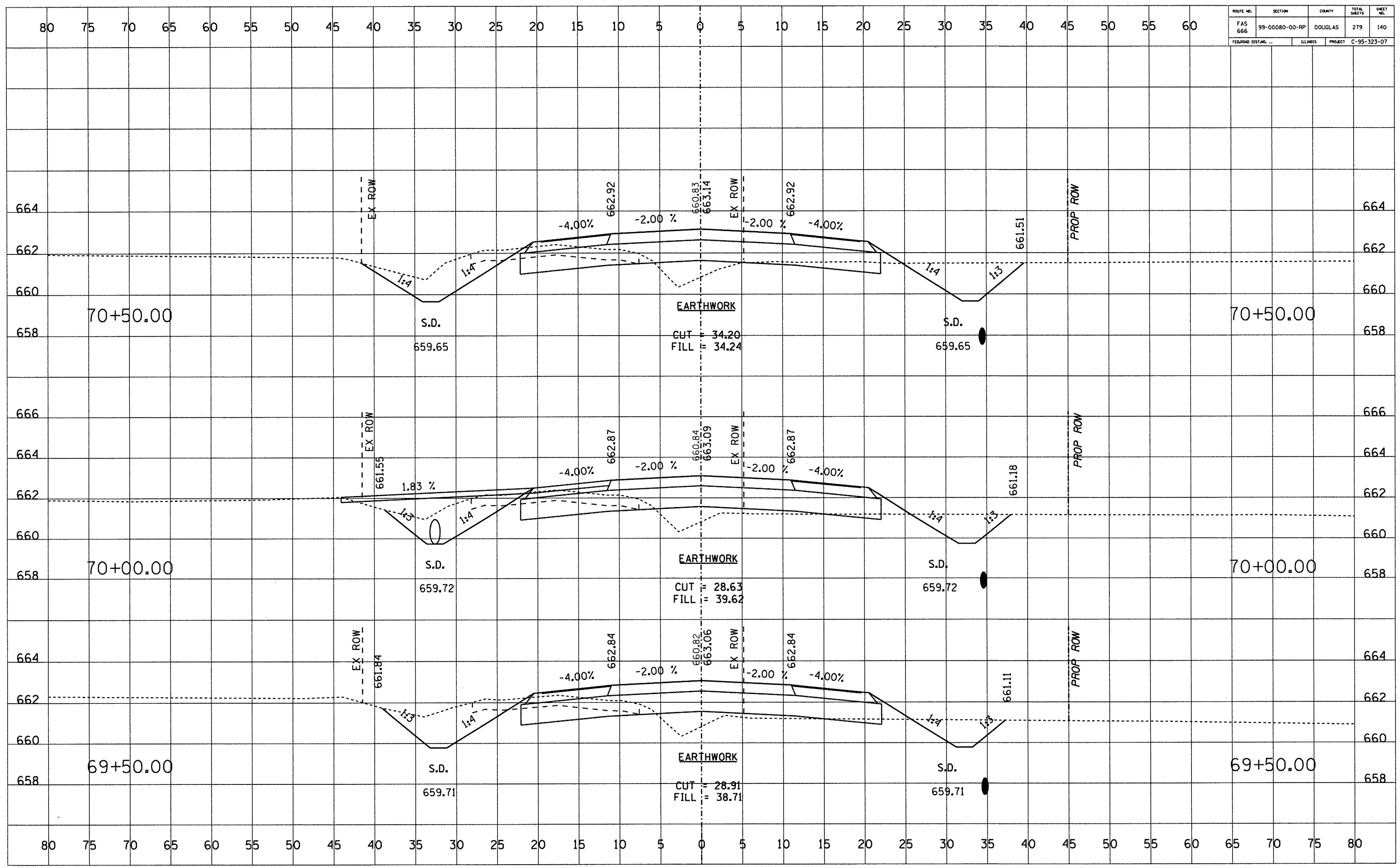



ROUTE NO.	SECTION	COUNTY	TOTAL SHEETS	SHEET NO.
FAS 666	99-00080-00-RP	DOUGLAS	279	141
FEDERAL DIST. NO.		ILLINOIS	PROJECT C-95-323-07	

DATE	
BY	
ORIGINAL SURVEY	
PLOTTED	
TEMPLATE	
NOTE BOOK	
AREAS CHECKED	
NO.	

DATE	
BY	
ORIGINAL SURVEY	
PLOTTED	
TEMPLATE	
NOTE BOOK	
AREAS CHECKED	
NO.	

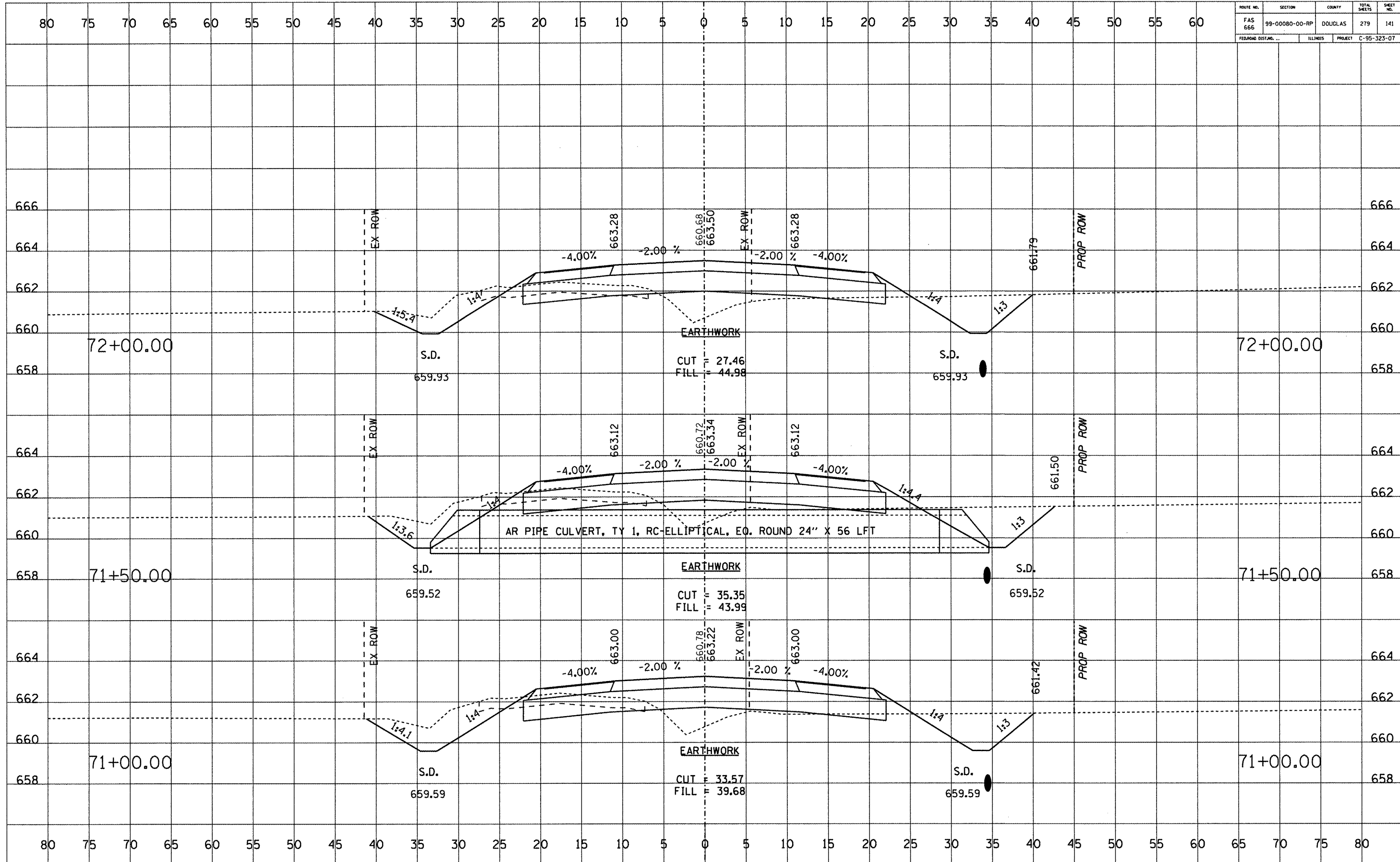

ROUTE NO.	SECTION	COUNTY	TOTAL SHEETS	SHEET NO.
FAS 666	99-00080-00-RP	DOUGLAS	279	142
FEDERAL DIST. NO.	ILLINOIS	PROJECT	C-95-323-07	

DATE	BY

FINAL SURVEY	SUPERVED

DATE	BY

ORIGINAL SURVEY	SUPERVED

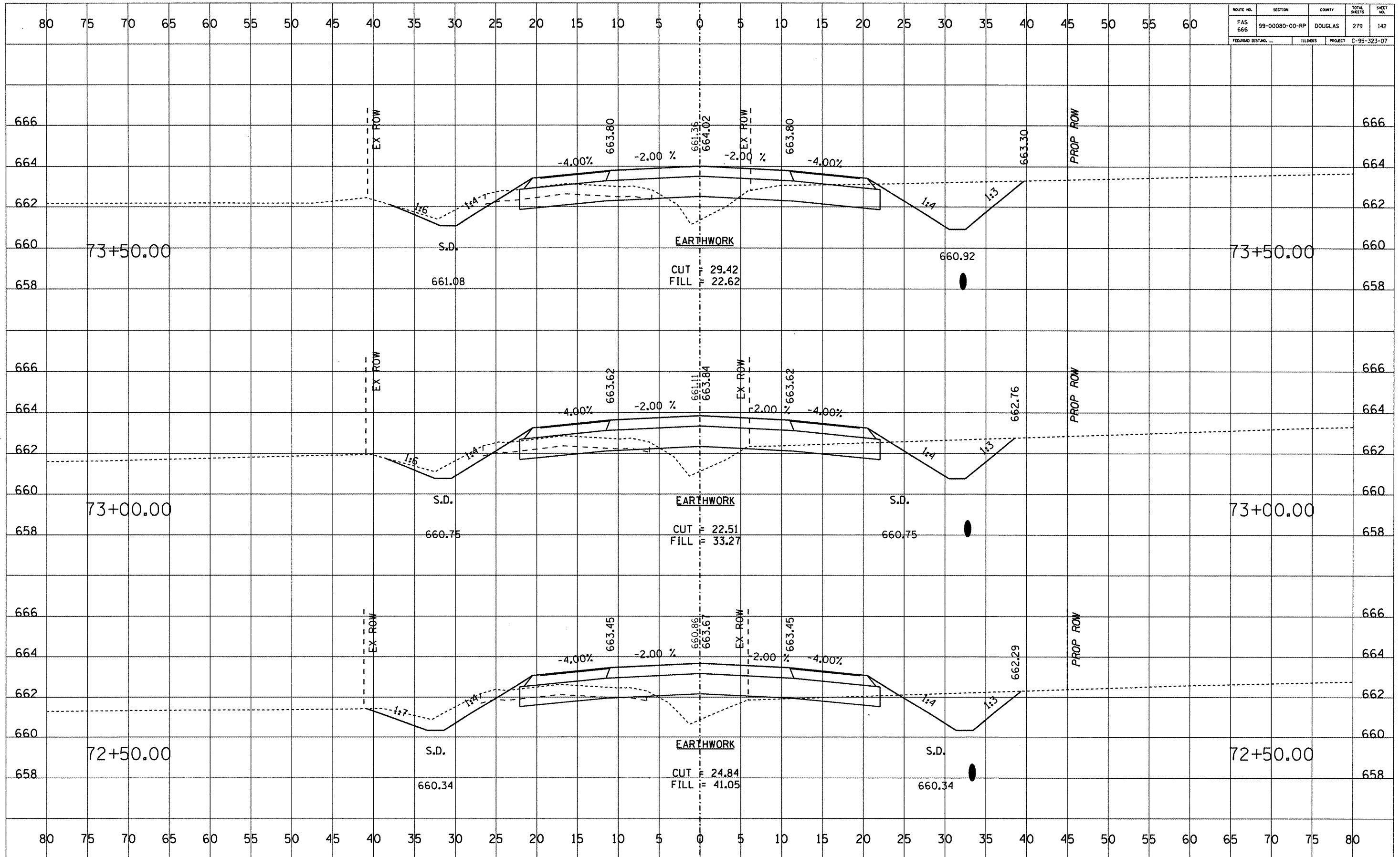

ROUTE NO.	SECTION	COUNTY	TOTAL SHEETS	SHEET NO.
FAS 666	99-00080-00-RP	DOUGLAS	279	143
FEDORAD ESTABL. ...	ILLINOIS	PROJECT	C-95-323-07	

DATE	BY	FINAL SURVEY	SURVEYED	PLOTTED	APPROVED	AREAS CHECKED

DATE	BY	ORIGINAL SURVEY	SURVEYED	PLOTTED	APPROVED	AREAS CHECKED

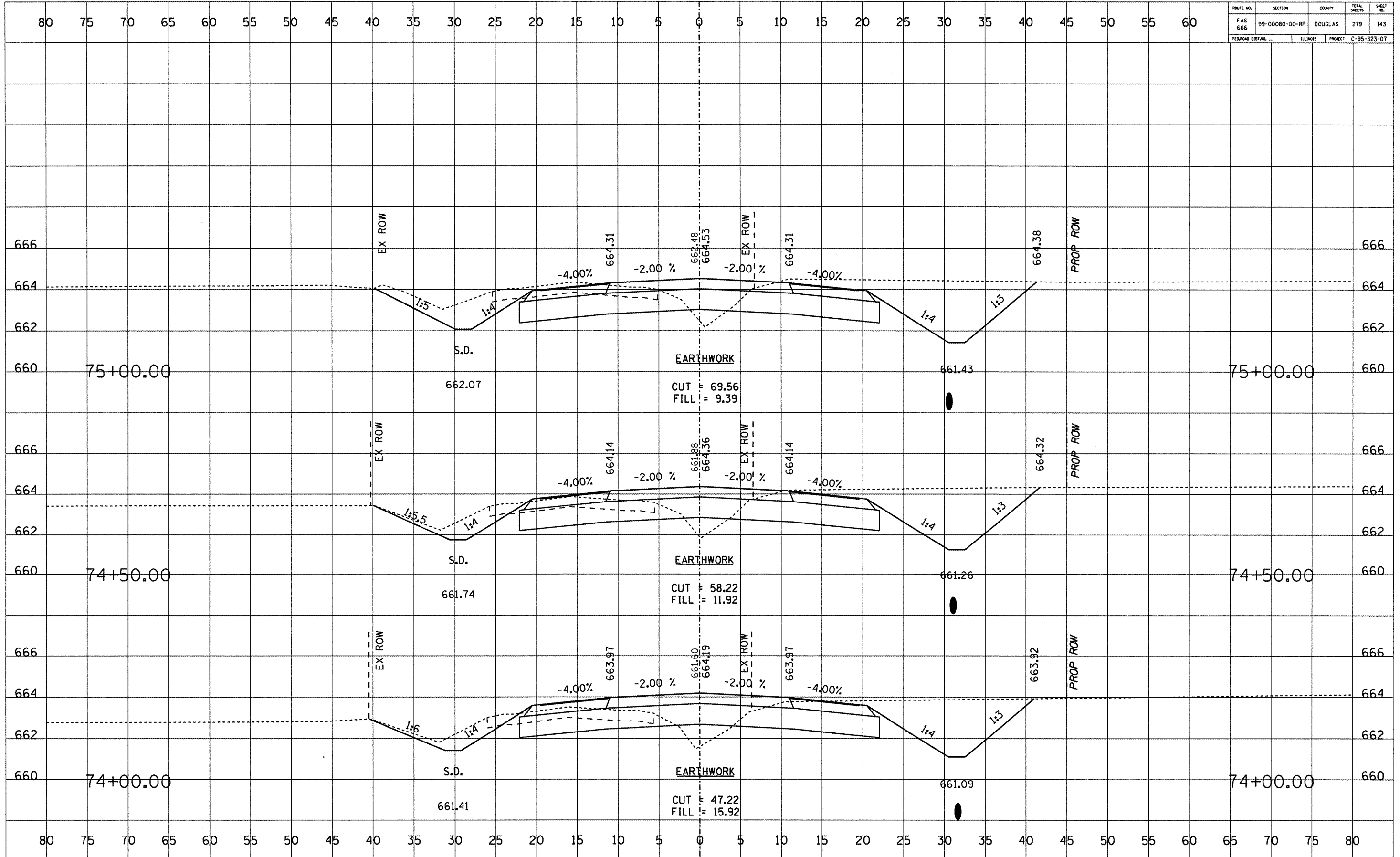

ROUTE NO.	SECTION	COUNTY	TOTAL SHEETS	SHEET NO.
FAS 666	99-00080-00-RP	DOUGLAS	279	144
FEDERAL DISTRICT	ILLINOIS	PROJECT	C-95-323-07	

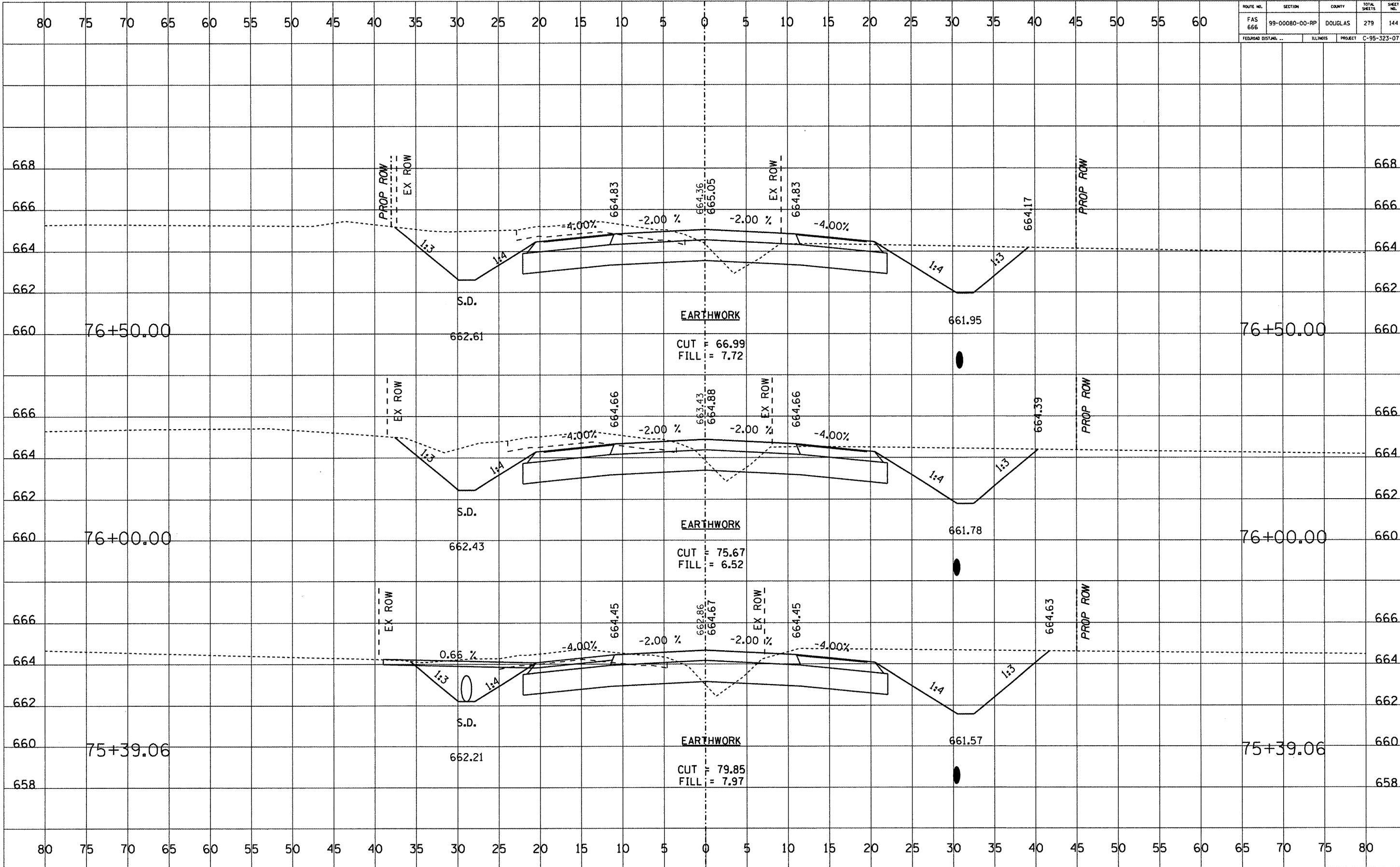

DATE	BY

NO.	AREAS CHECKED

DATE	BY

NO.	AREAS CHECKED



ROUTE NO.	SECTION	COUNTY	TOTAL SHEETS	SHEET NO.
FAS 666	99-00080-00-RP	DOUGLAS	279	146
FEDERAL DISTRICT		ILLINOIS	PROJECT C-95-323-07	

DATE	
BY	
FINAL SURVEY	
SURVEYED	
PLOTTED	
TEMPLATE	
NOTE BOOK	
AREAS CHECKED	
NO.	

DATE	
BY	
ORIGINAL SURVEY	
SURVEYED	
PLOTTED	
TEMPLATE	
NOTE BOOK	
AREAS CHECKED	
NO.	

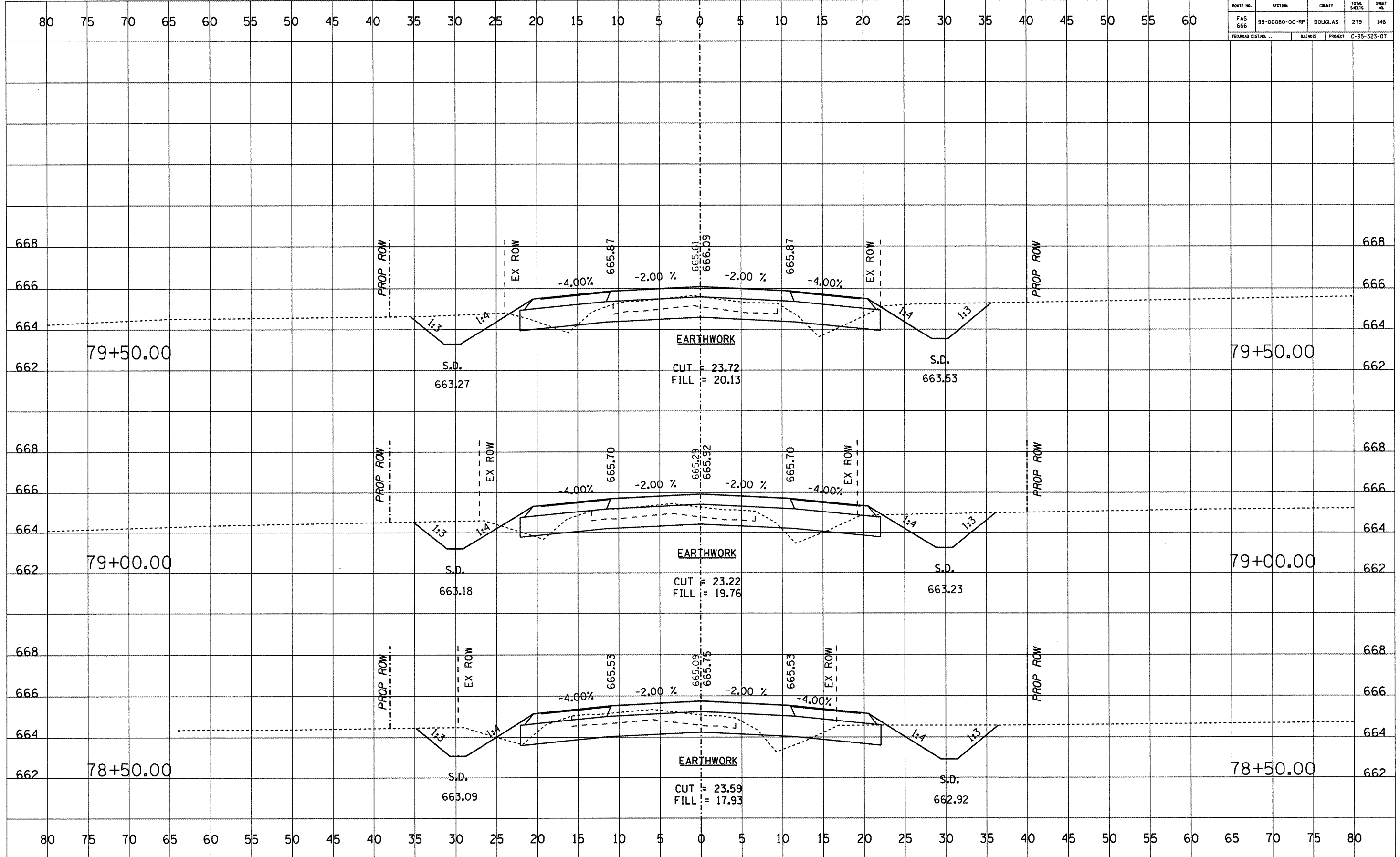

ROUTE NO.	SECTION	COUNTY	TOTAL SHEETS	SHEET NO.
FAS 666	99-00080-00-RP	DOUGLAS	279	147
FEDERAL DIST. NO.	ILLINOIS	PROJECT	C-95-323-07	

DATE	BY

DATE	BY

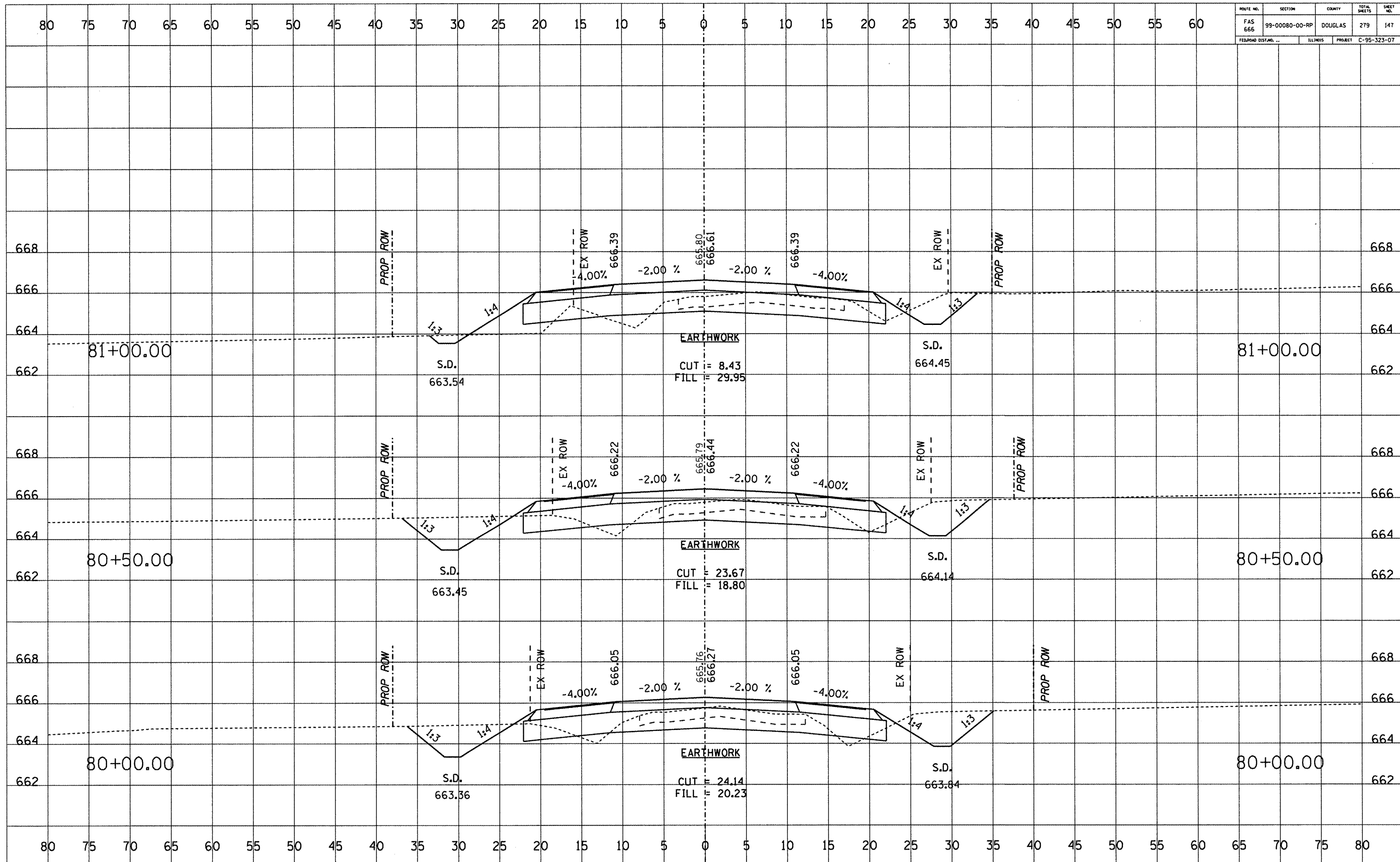

ROUTE NO.	SECTION	COUNTY	TOTAL SHEETS	SHEET NO.
FAS 666	99-00080-00-RP	DOUGLAS	279	148
FEDERAL DIST. NO.	ILLINOIS	PROJECT	C-95-323-07	

DATE	BY	FINAL SURVEY	SURVEYED	PLOTTED	REPLATE	NO. BOOK	AREAS CHECKED

DATE	BY	ORIGINAL SURVEY	SURVEYED	PLOTTED	REPLATE	NO. BOOK	AREAS CHECKED

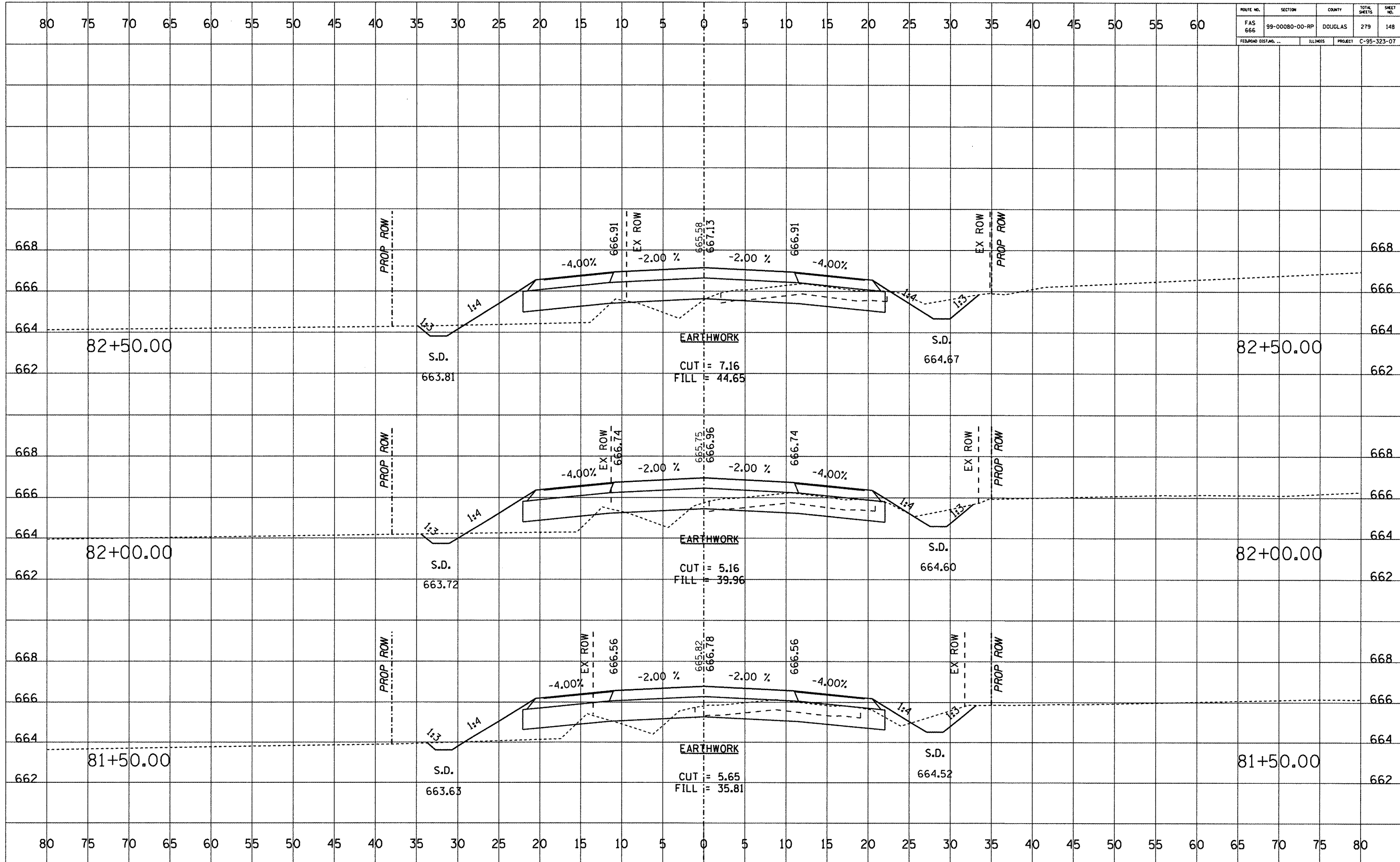



ROUTE NO.	SECTION	COUNTY	TOTAL SHEETS	SHEET NO.
FAS 666	99-00080-00-RP	DOUGLAS	279	149
FEDERAL DIST. NO.		ILLINOIS	PROJECT C-95-323-07	

DATE	BY

DATE	BY

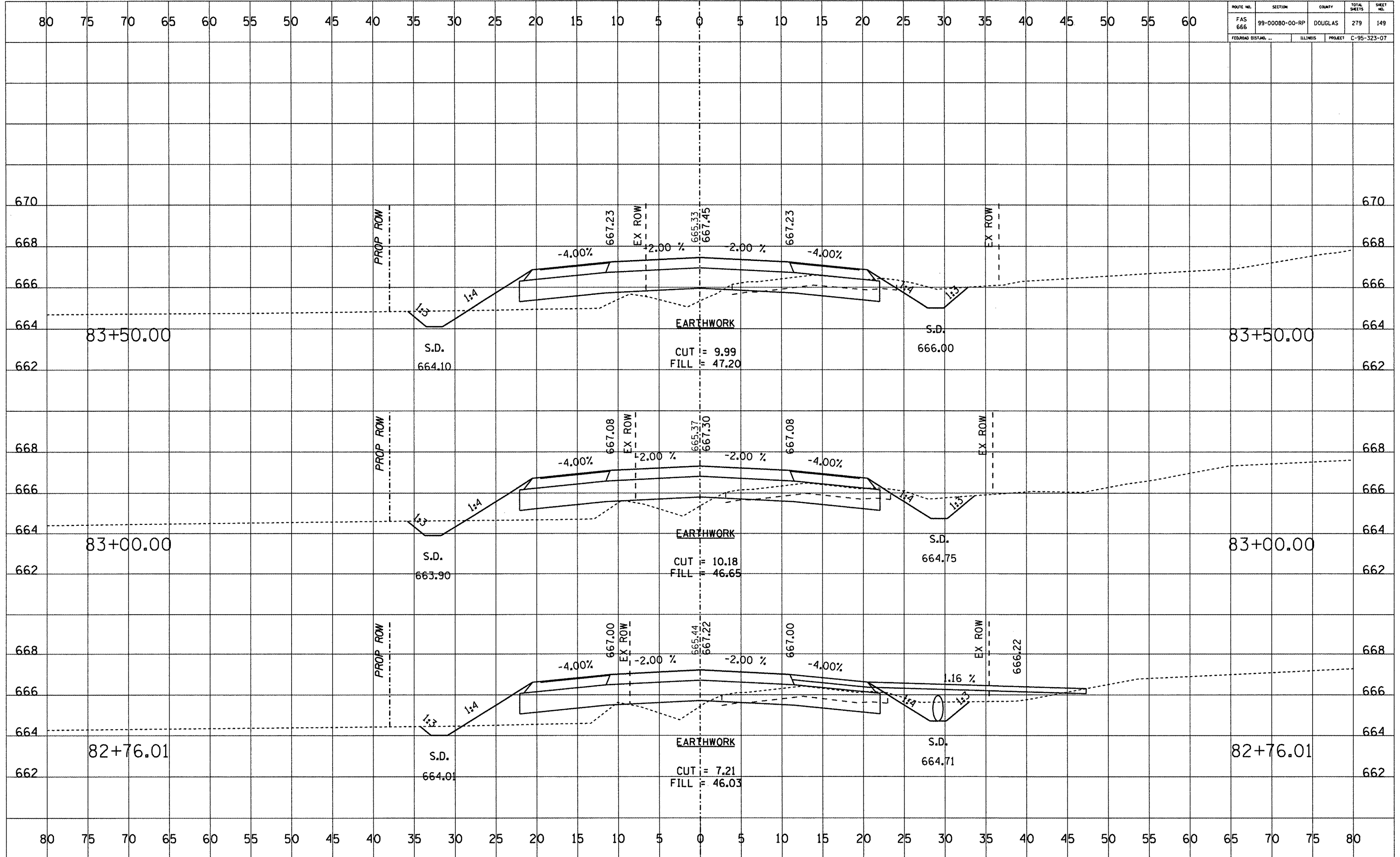

ROUTE NO.	SECTION	COUNTY	TOTAL SHEETS	SHEET NO.
FAS 666	99-00080-00-RP	DOUGLAS	279	150
FEDERAL DIST. NO. ...		ILLINOIS	PROJECT C-95-323-07	

DATE	BY	FINISHED	SURVEY	NOTED	PLOTTED	TEMPERATURE	AREAS CHECKED

DATE	BY	ORIGINAL	SURVEY	NOTED	PLOTTED	TEMPERATURE	AREAS CHECKED

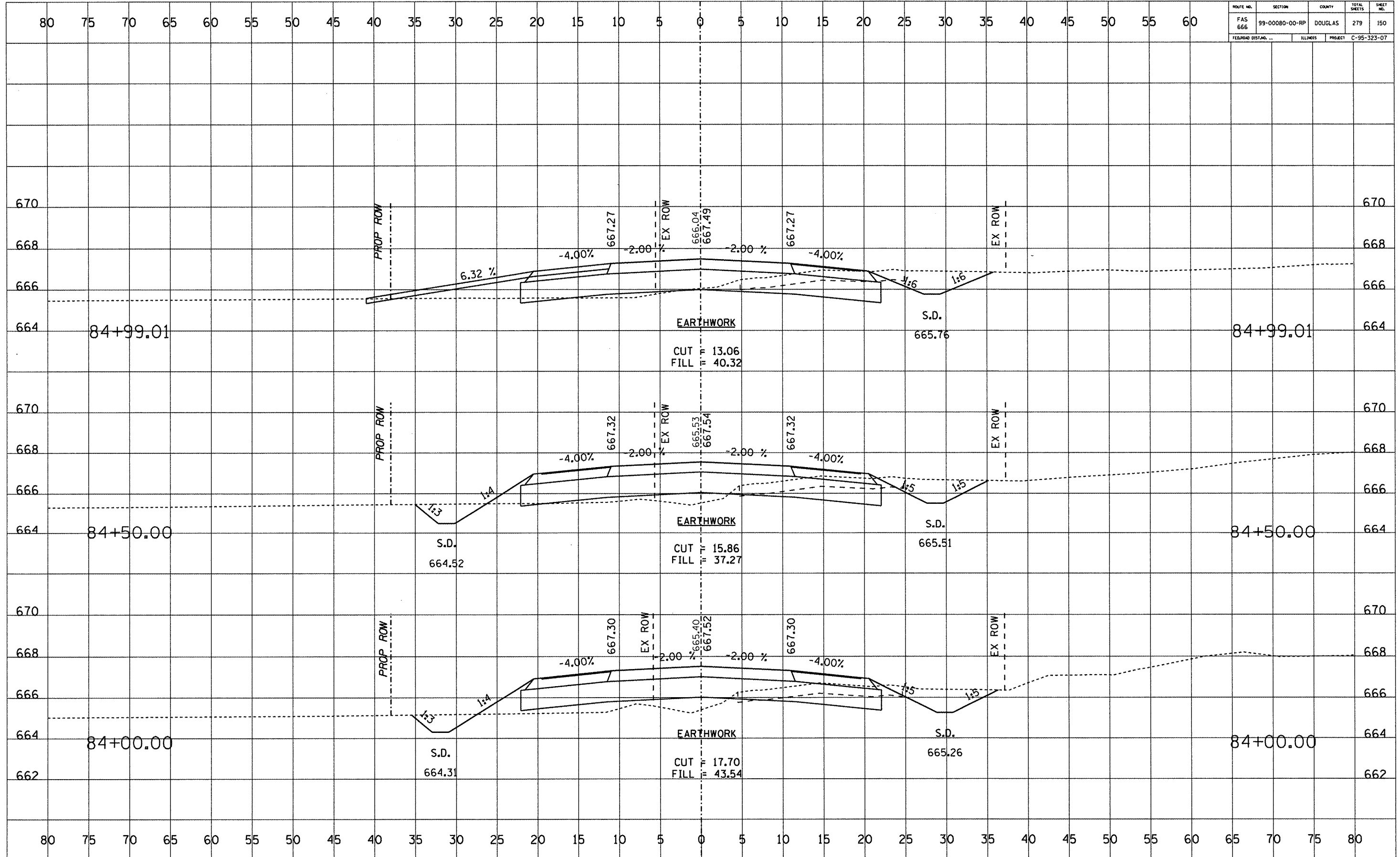

ROUTE NO.	SECTION	COUNTY	TOTAL SHEETS	SHEET NO.
FAS 666	99-00080-00-RP	DOUGLAS	279	151
FEDERAL DISTRICT		ILLINOIS	PROJECT C-95-323-07	

DATE	
BY	
NO.	
FINAL SURVEY	
REQUESTED	
PLOTTED	
TEMPLATE	
AREAS CHECKED	

DATE	
BY	
NO.	
ORIGINAL SURVEY	
REQUESTED	
PLOTTED	
TEMPLATE	
AREAS CHECKED	

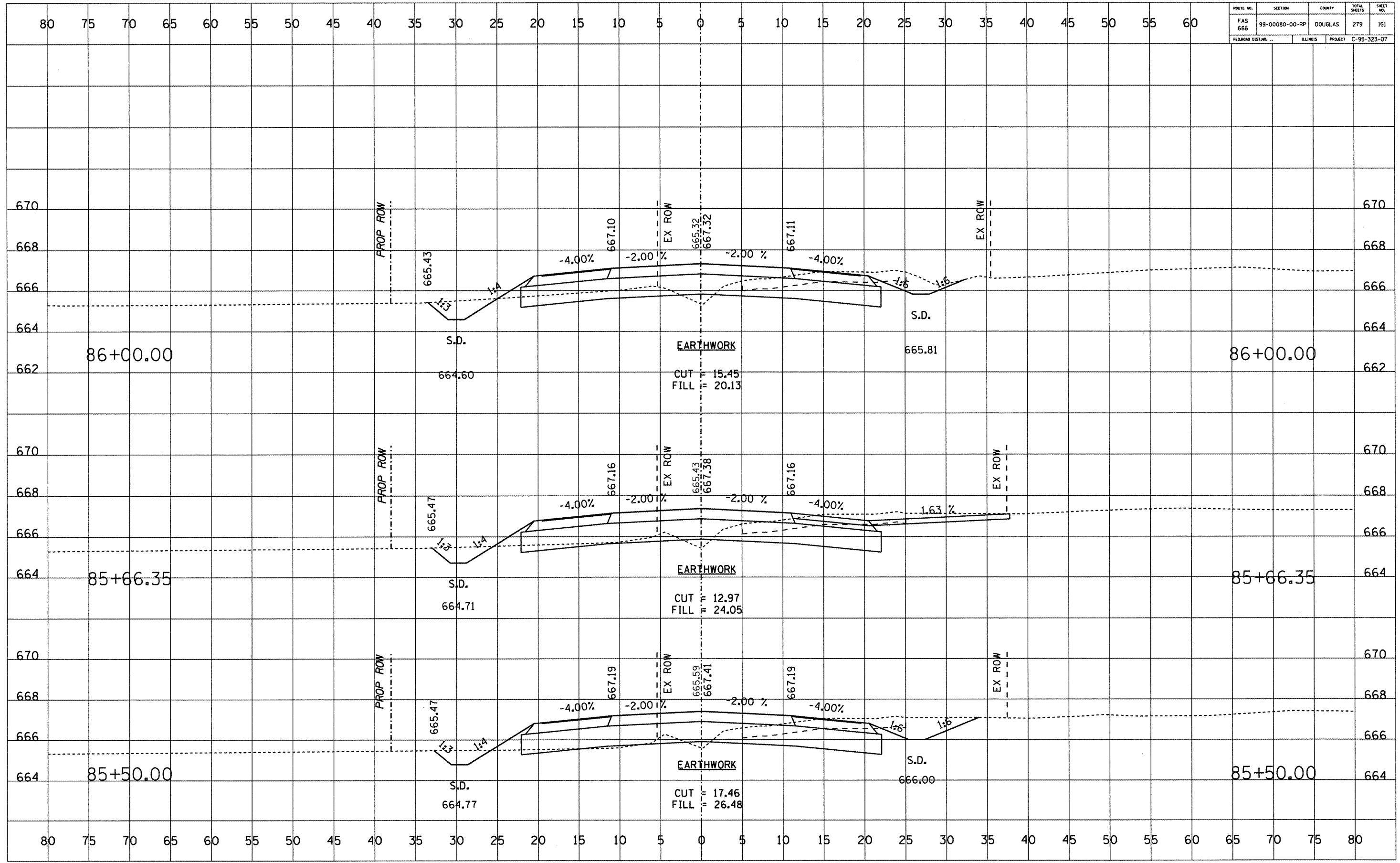

ROUTE NO.	SECTION	COUNTY	TOTAL SHEETS	SHEET NO.
FAS 666	99-00080-00-RP	DOUGLAS	279	152
FEDERAL DIST. NO.	ILLINOIS	PROJECT	C-95-323-07	

DATE	BY

DATE	BY

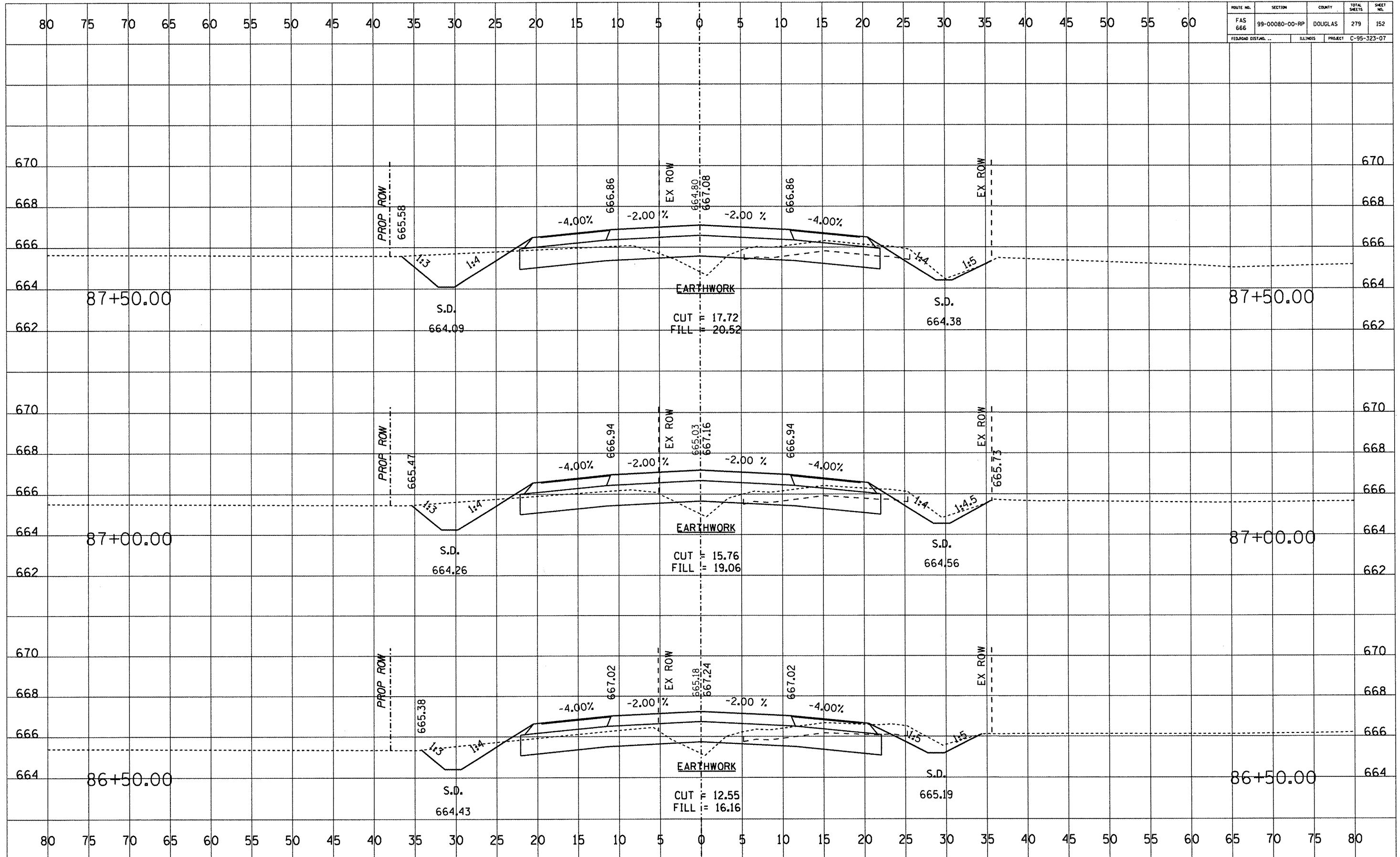

ROUTE NO.	SECTION	COUNTY	TOTAL SHEETS	SHEET NO.
FAS 666	99-00080-00-RP	DOUGLAS	279	153
FEDERAL DIST. NO.	ILLINOIS	PROJECT	C-95-323-07	

DATE	BY
DATE	BY
DATE	BY
DATE	BY
DATE	BY

DATE	BY
DATE	BY
DATE	BY
DATE	BY
DATE	BY

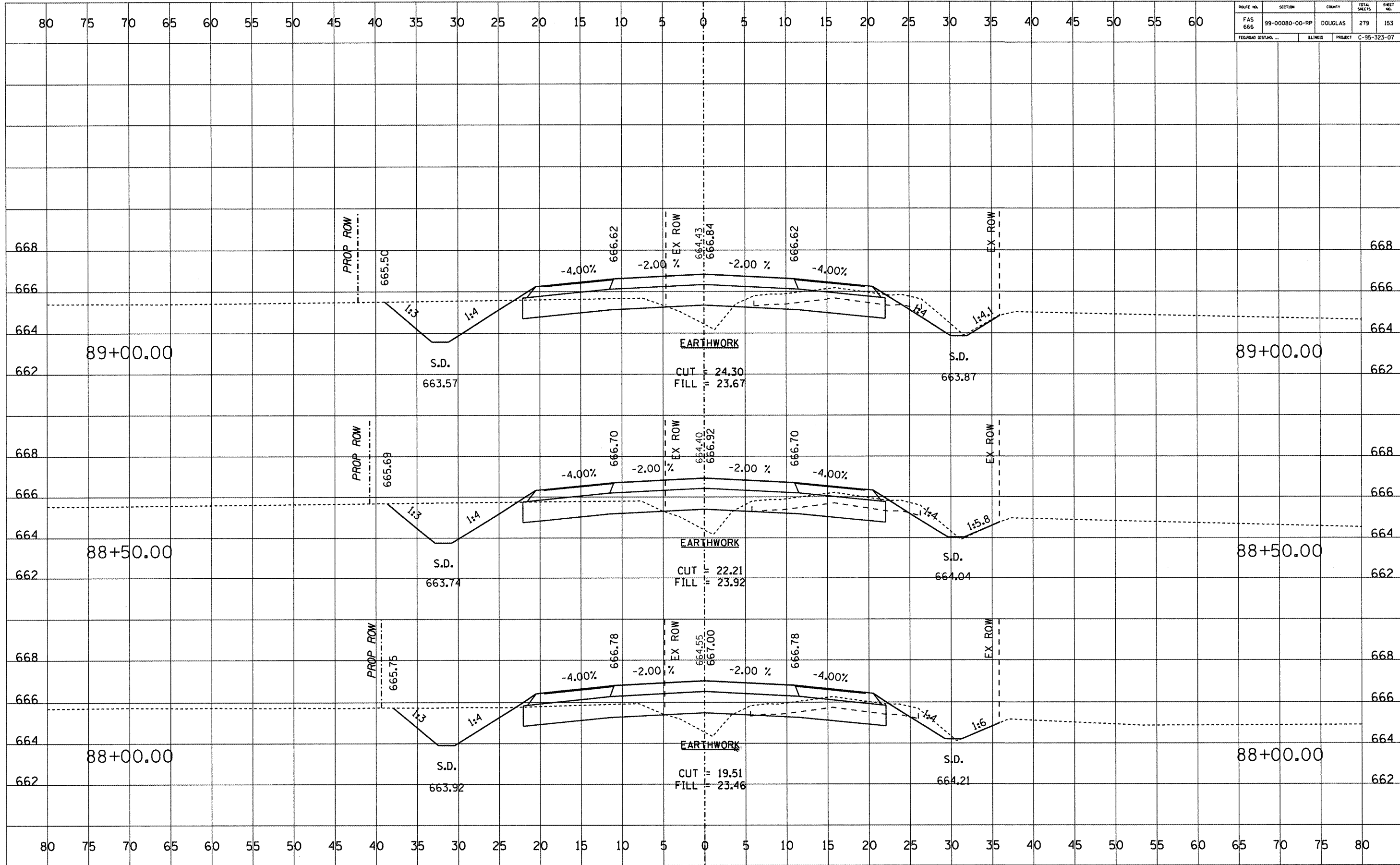

ROUTE NO. FAS 666	SECTION 99-00080-00-RP	COUNTY DOUGLAS	TOTAL SHEETS 279	SHEET NO. 154
FEDERAL DISTRICT		ILLINOIS	PROJECT C-95-323-07	

DATE	
BY	
NO.	
ORIGINAL SURVEY	
SURVEYED	
PLOTTED	
TEMPLATE	
NOTE BOOK	
AREAS CHECKED	

DATE	
BY	
NO.	
ORIGINAL SURVEY	
SURVEYED	
PLOTTED	
TEMPLATE	
NOTE BOOK	
AREAS CHECKED	

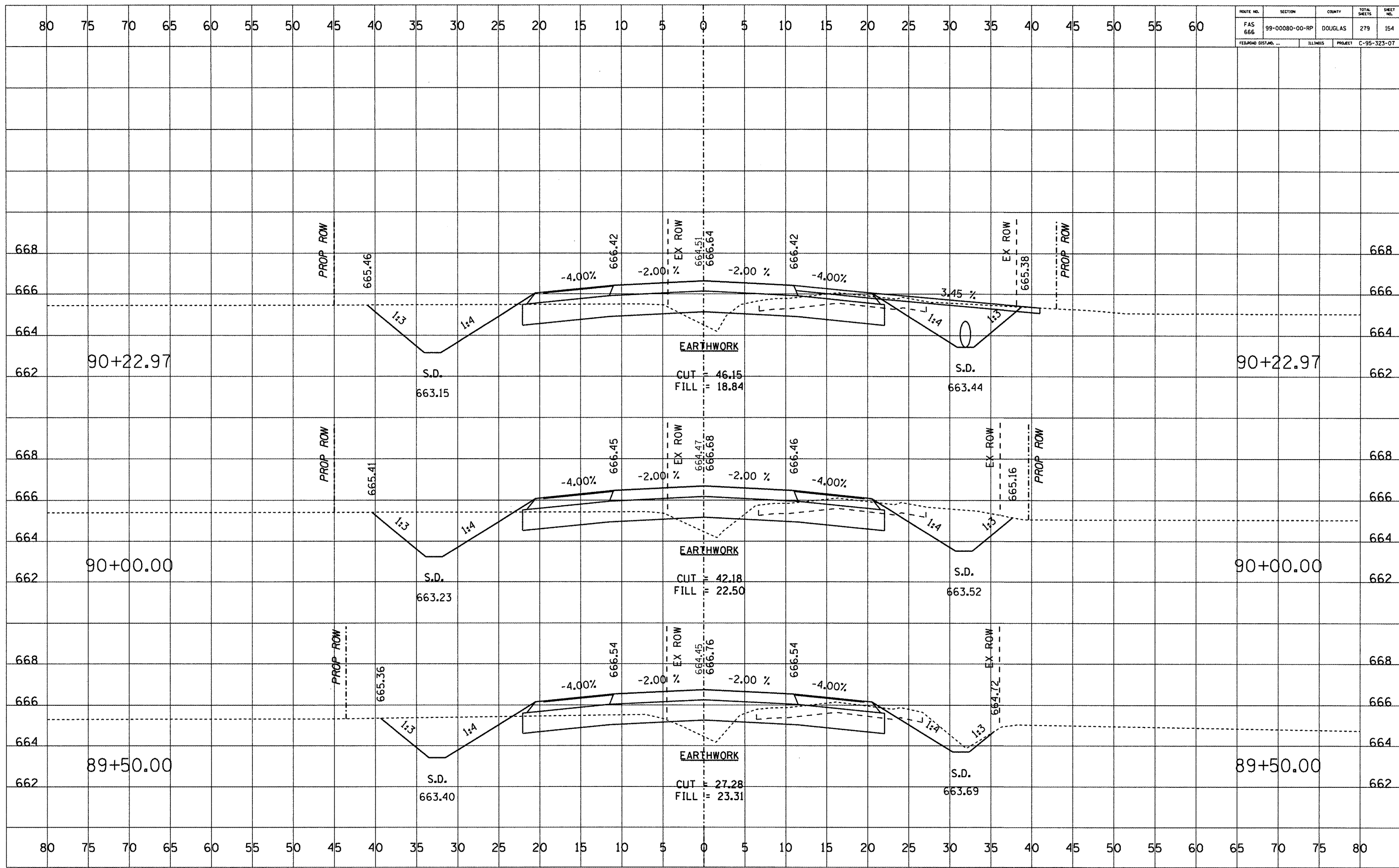

ROUTE NO.	SECTION	COUNTY	TOTAL SHEETS	SHEET NO.
FAS 666	99-00080-00-RP	DOUGLAS	279	155
FEDERAL DIST. NO. ...		ILLINOIS	PROJECT	C-95-323-07

DATE	
BY	
FINAL SURVEY	
PLOTTED	
NOTE BOOK	
AREAS CHECKED	

DATE	
BY	
ORIGINAL SURVEY	
PLOTTED	
NOTE BOOK	
AREAS CHECKED	

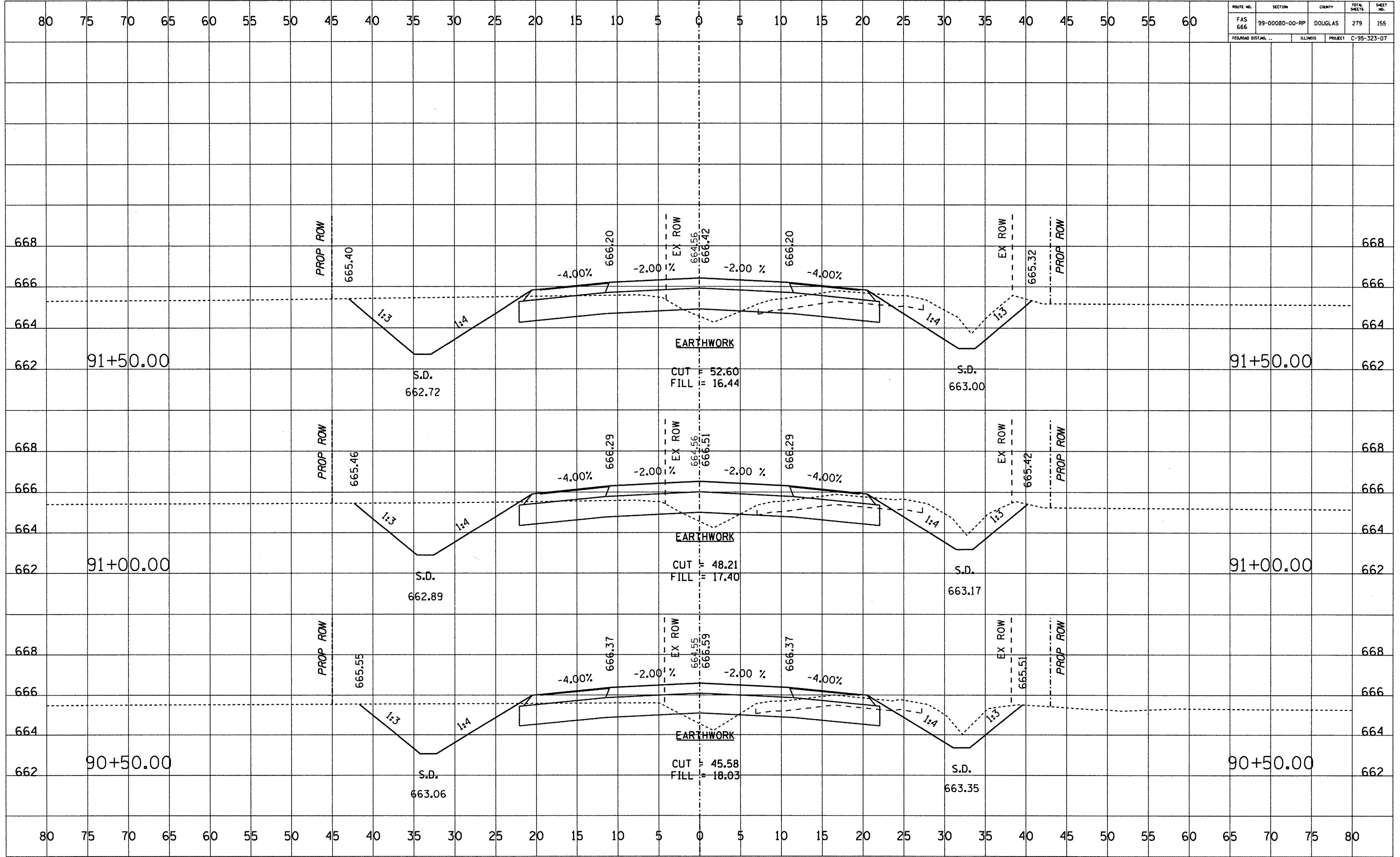

ROUTE NO.	SECTION	COUNTY	TOTAL SHEETS	SHEET NO.
FAS 666	99-00080-00-RP	DOUGLAS	279	156
FEDERAL DIST. NO. ...		ILLINOIS	PROJECT C-95-323-07	

DATE	
BY	
FINAL SURVEY	
EXTRACTED	
PLOTTED	
TEMPLATE	
NOTE BOOK	
NO.	
AREAS CHECKED	

DATE	
BY	
ORIGINAL SURVEY	
EXTRACTED	
PLOTTED	
TEMPLATE	
NOTE BOOK	
NO.	
AREAS CHECKED	

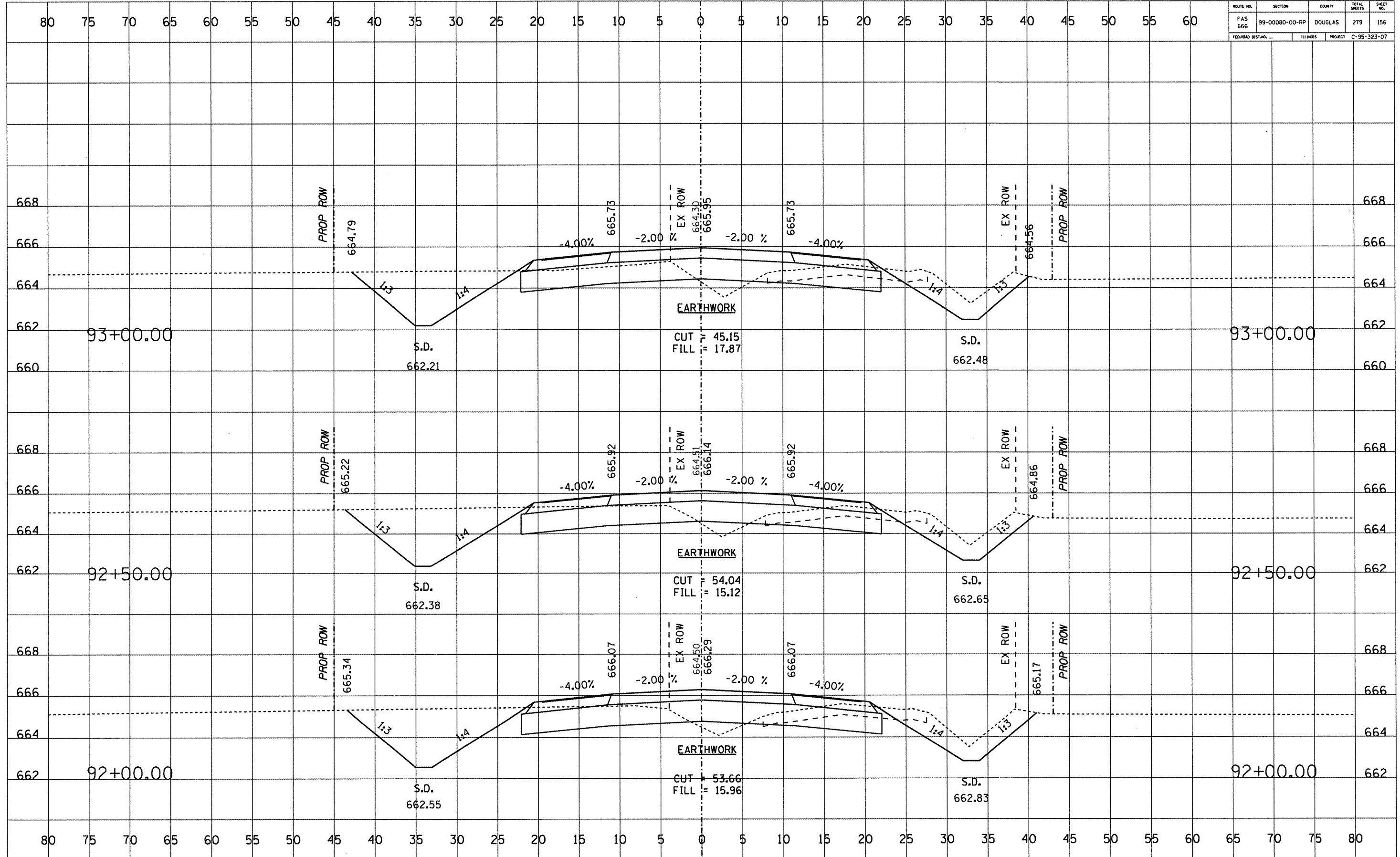



ROUTE NO.	SECTION	COUNTY	TOTAL SHEETS	SHEET NO.
FAS 666	99-00080-00-RP	DOUGLAS	279	157
FED. ROAD DIST. NO. ...		ILLINOIS	PROJECT	C-95-323-07

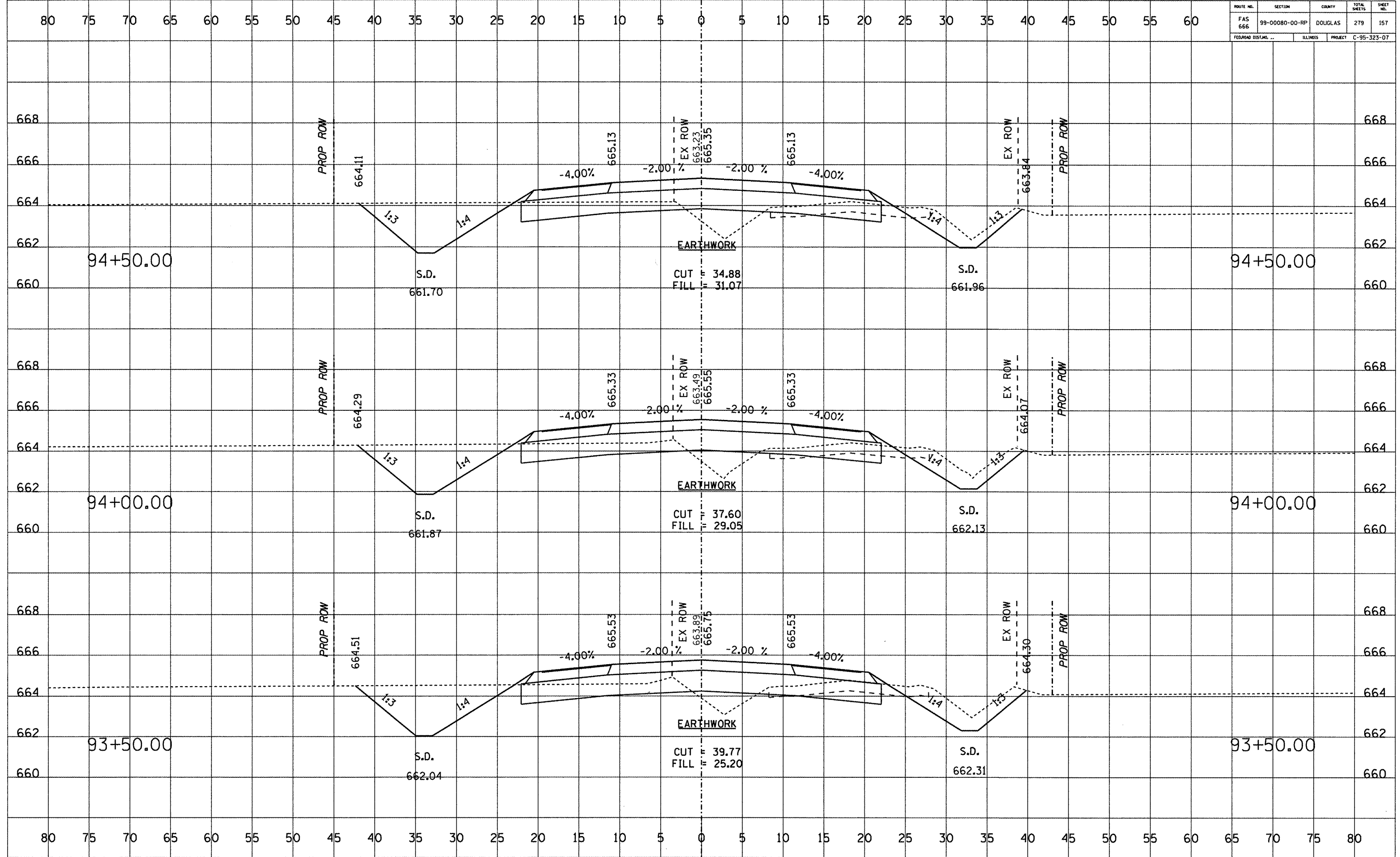

DATE	BY

NO.	AREAS CHECKED

DATE	BY

NO.	AREAS CHECKED

ROUTE NO.	SECTION	COUNTY	TOTAL SHEETS	SHEET NO.
FAS 666	99-00080-00-RP	DOUGLAS	279	158
FEDORAD DIST.NO.	ILLINOIS	PROJECT	C-95-323-07	

DATE	
BY	
FINAL SURVEY	
SURVEYED	
NOTED	
PLOTTED	
TEMPLATE	
AREAS CHECKED	

DATE	
BY	
ORIGINAL SURVEY	
SURVEYED	
NOTED	
PLOTTED	
TEMPLATE	
AREAS CHECKED	

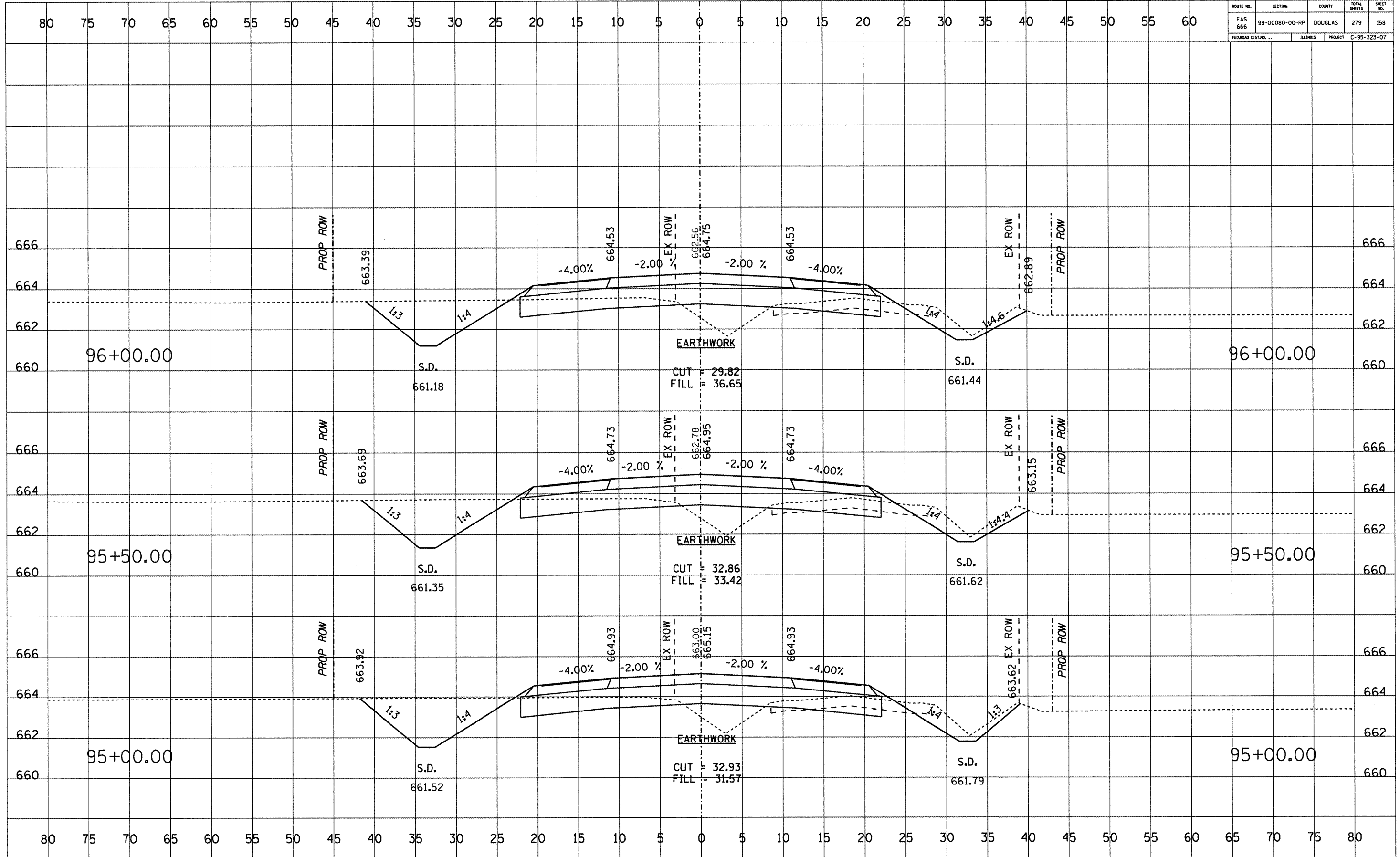

ROUTE NO.	SECTION	COUNTY	TOTAL SHEETS	SHEET NO.
FAS 666	99-00080-00-RP	DOUGLAS	279	159
FEDERAL DIST. NO.		ILLINOIS	PROJECT C-95-323-07	

DATE	BY

DATE	BY

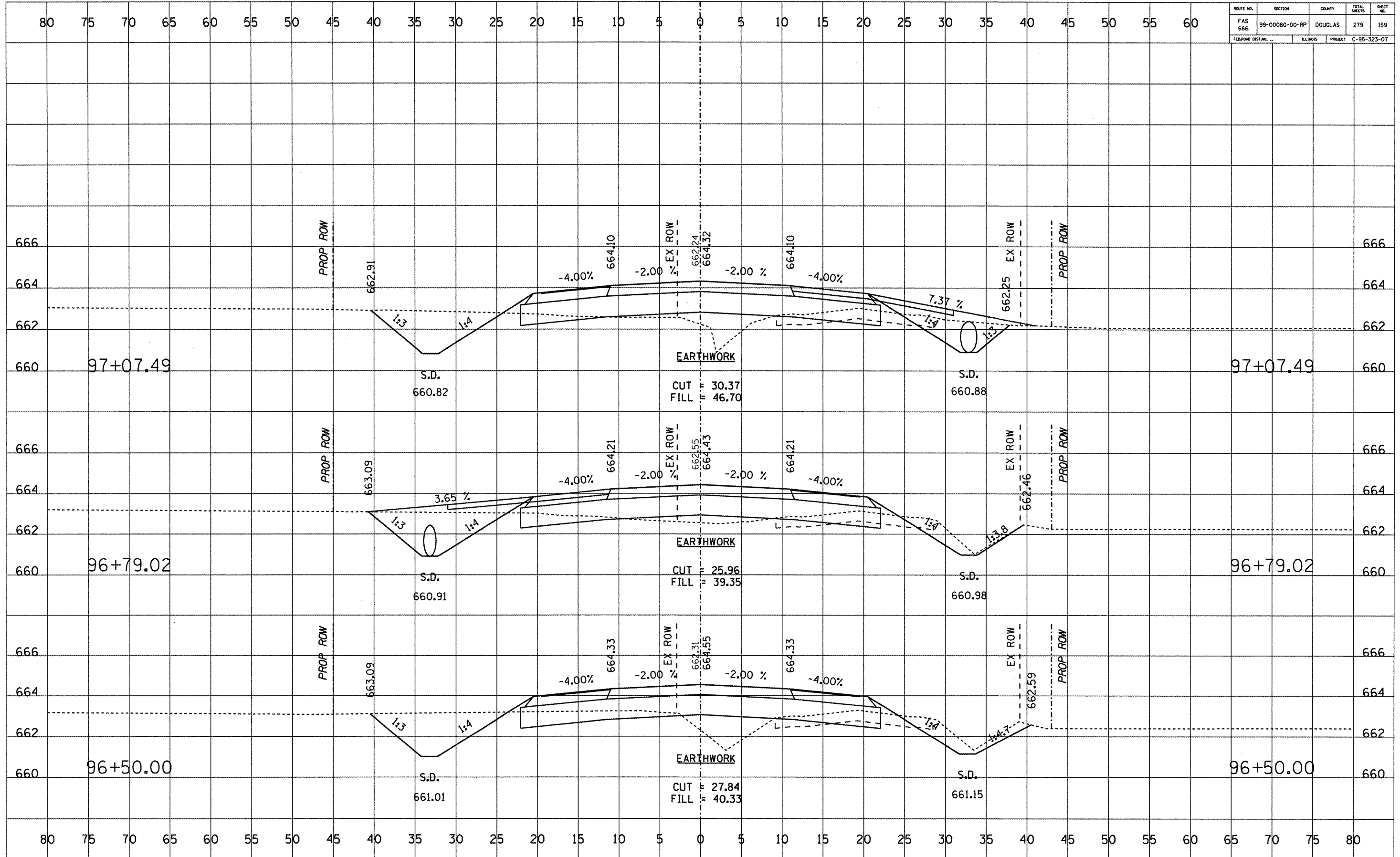

ROUTE NO.	SECTION	COUNTY	TOTAL SHEETS	SHEET NO.
FAS 666	99-00080-00-RP	DOUGLAS	279	160
FEDERAL DIST. NO.		ILLINOIS	PROJECT	C-95-323-07

DATE	BY

  

FINL SURVEY	SURVEYED	PLOTTED	REPLATE	AREAS CHECKED

DATE	BY

ORIGINAL SURVEY	SURVEYED	PLOTTED	REPLATE	AREAS CHECKED

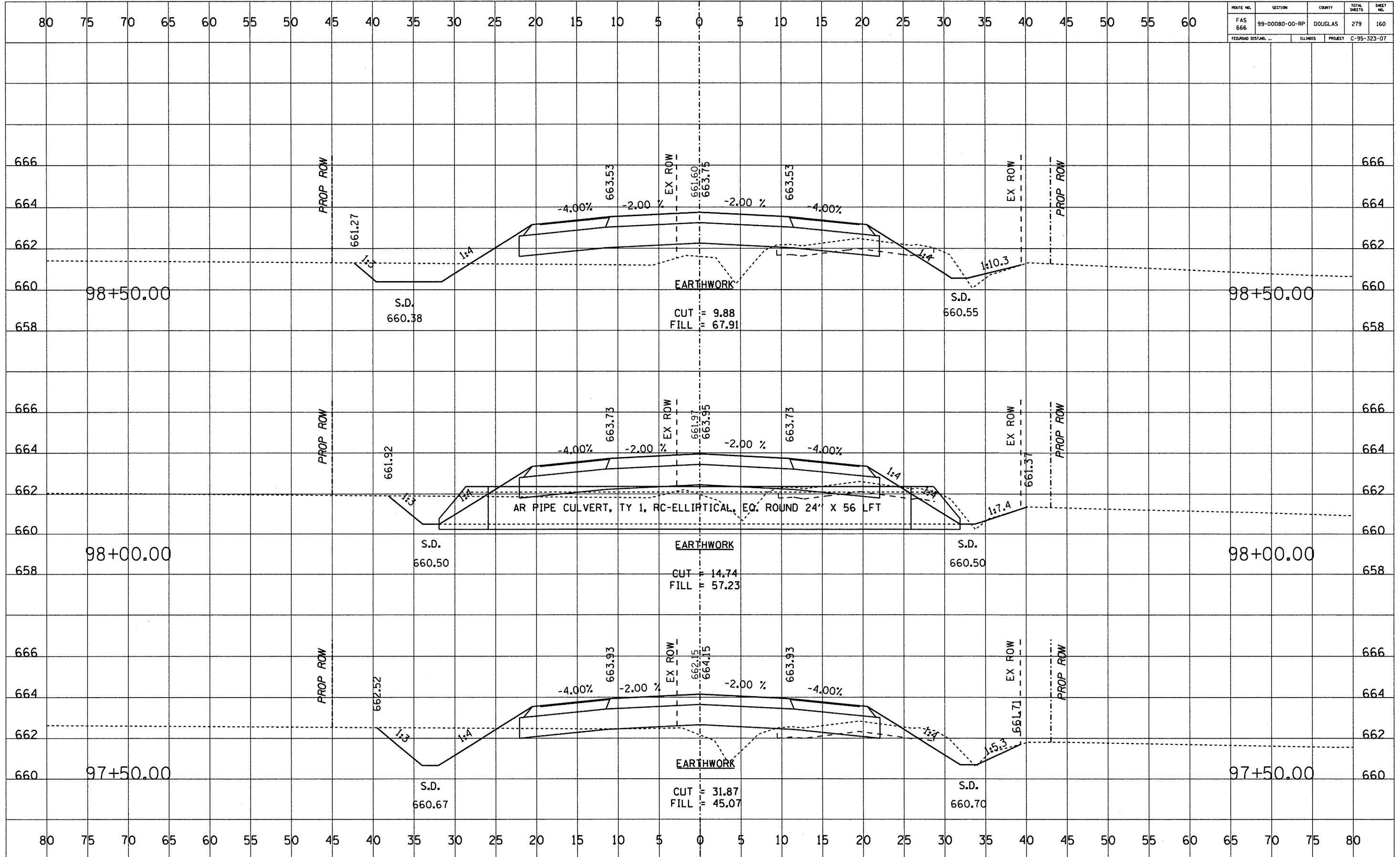

ROUTE NO.	SECTION	COUNTY	TOTAL SHEETS	SHEET NO.
FAS 666	99-0080-00-RP	DOUGLAS	279	161
FEDERAL DISTRICT		ILLINOIS	PROJECT	C-95-323-07

DATE	BY

DATE	BY

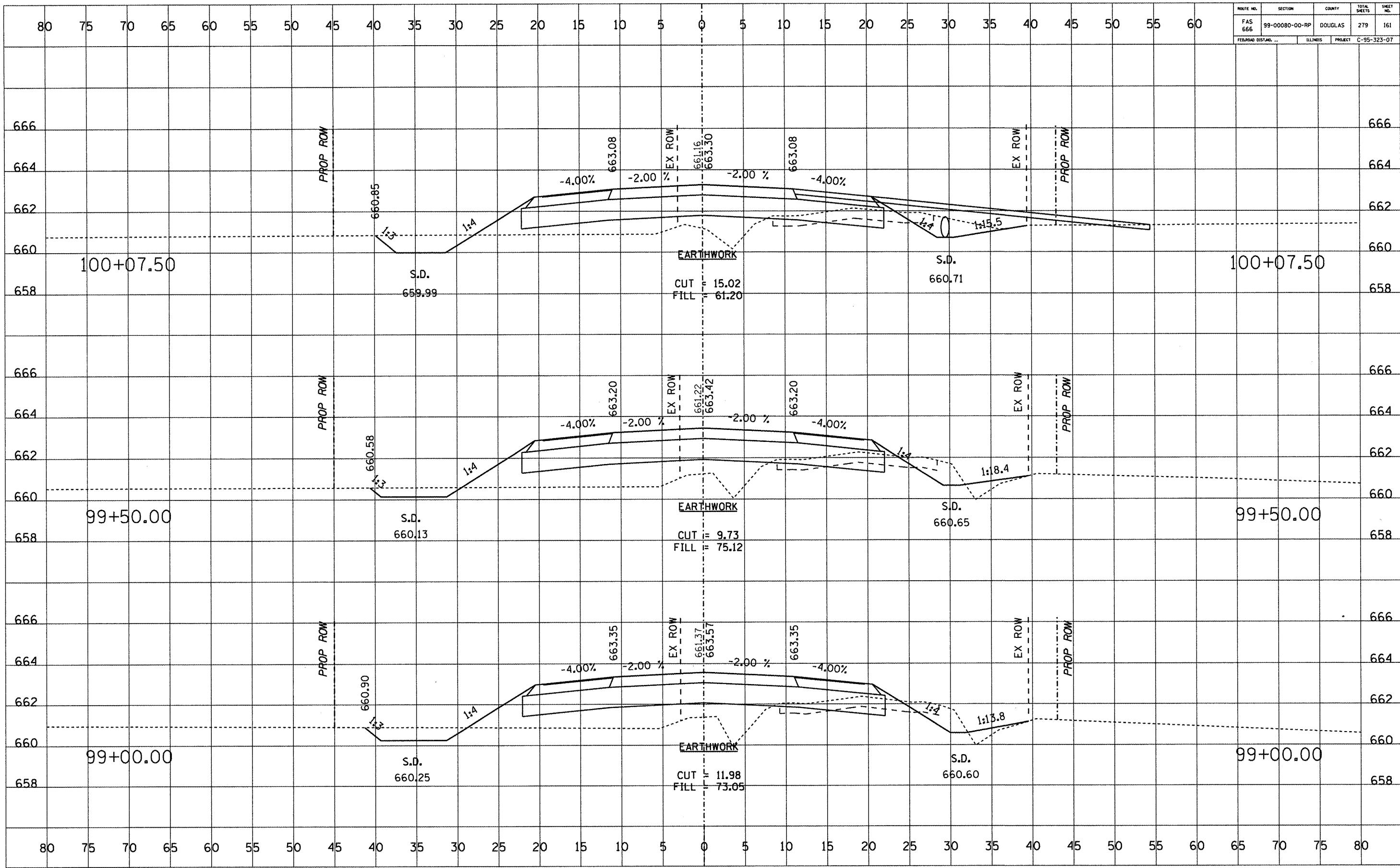

ROUTE NO.	SECTION	COUNTY	TOTAL SHEETS	SHEET NO.
FAS 666	99-00080-00-RP	DOUGLAS	279	162
FEDERAL DISTRICT...		ILLINOIS	PROJECT	C-95-323-07

DATE	BY	APPROVED	DATE
FINAL SURVEY	REVISIONS	REVISIONS	REVISIONS
NOTE BOOK NO.	TEMPLATE	TEMPLATE	TEMPLATE
	AREAS CHECKED	AREAS CHECKED	AREAS CHECKED

DATE	BY	APPROVED	DATE
ORIGINAL SURVEY	REVISIONS	REVISIONS	REVISIONS
NOTE BOOK NO.	TEMPLATE	TEMPLATE	TEMPLATE
	AREAS CHECKED	AREAS CHECKED	AREAS CHECKED

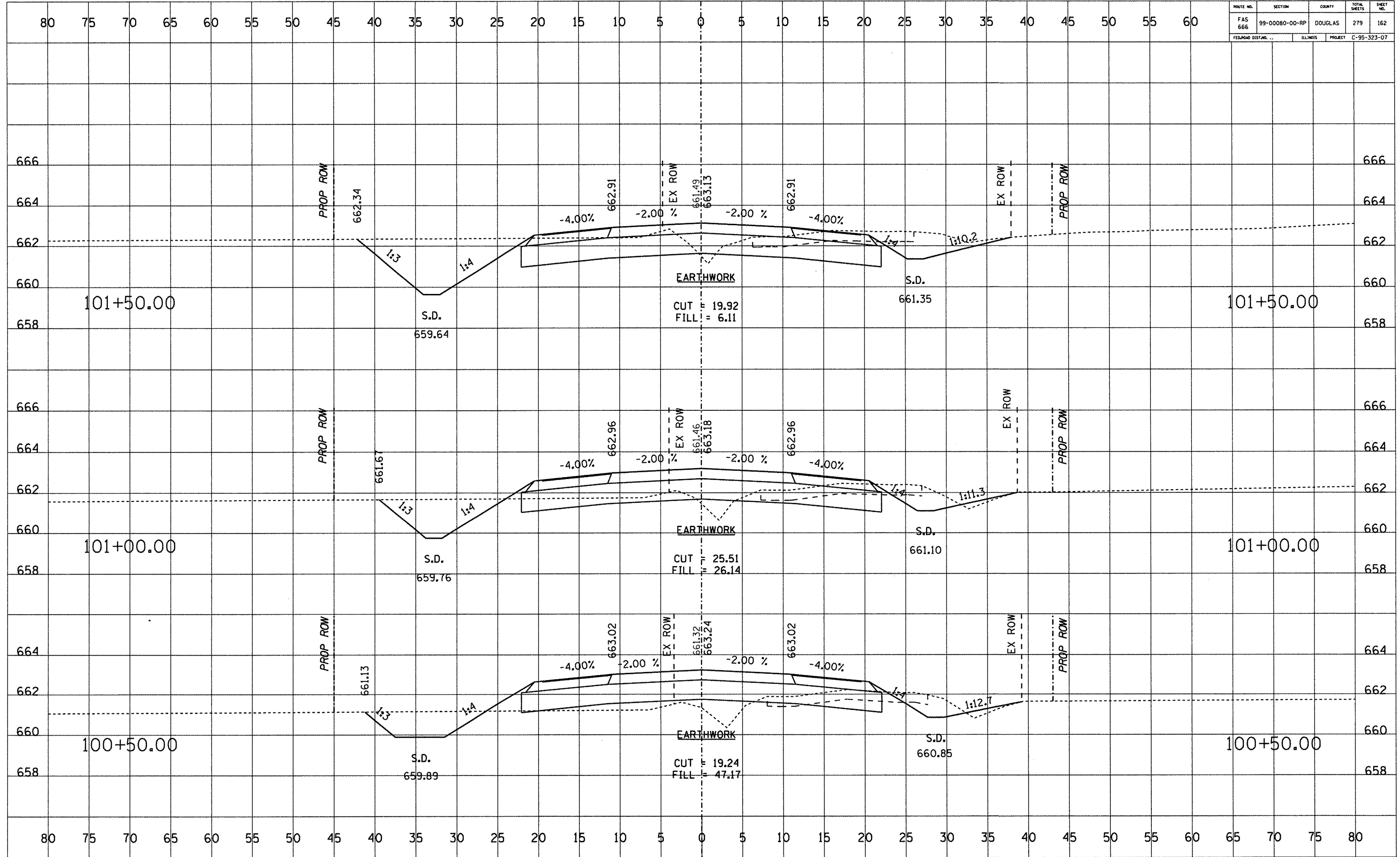

ROUTE NO.	SECTION	COUNTY	TOTAL SHEETS	SHEET NO.
FAS 666	99-00080-00-RP	DOUGLAS	279	163
FEDERAL DIST. NO.		ILLINOIS	PROJECT C-95-323-07	

DATE	
BY	
FINAL SURVEY	
SURVEY	
NOTED	
NO. CHECKED	
AREAS	
NO.	

DATE	
BY	
ORIGINAL SURVEY	
SURVEY	
NOTED	
NO. CHECKED	
AREAS	
NO.	

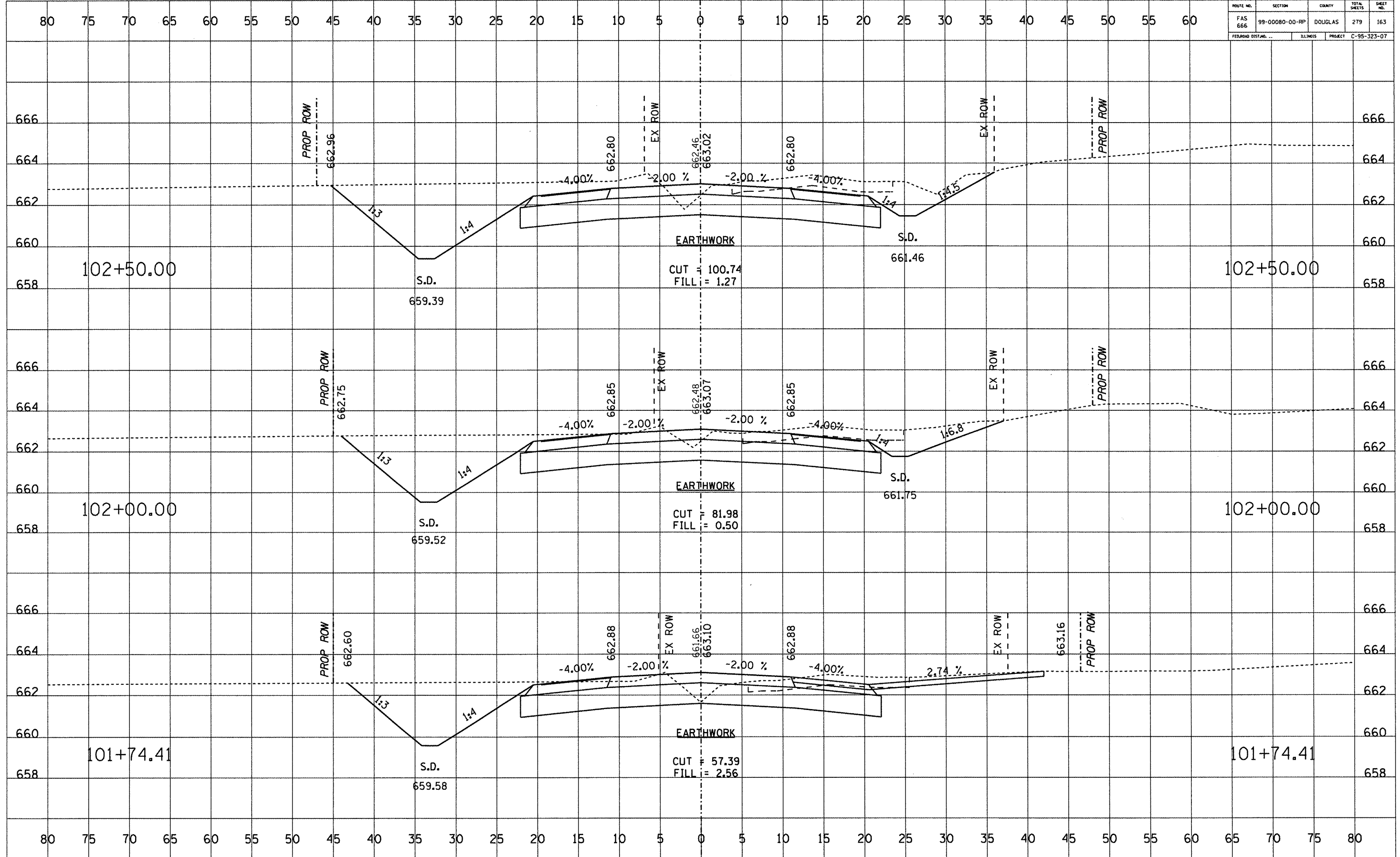

ROUTE NO.	SECTION	COUNTY	TOTAL SHEETS	SHEET NO.
FAS 666	99-00080-00-RP	DOUGLAS	279	164
FEDERAL DIST. NO.		ILLINOIS	PROJECT C-95-323-07	

DATE	
BY	
FINAL SURVEY	
PLOTTED	
TEMPLATE	
NOTE BOOK	
AREAS CHECKED	
NO.	

DATE	
BY	
ORIGINAL SURVEY	
PLOTTED	
TEMPLATE	
NOTE BOOK	
AREAS CHECKED	
NO.	

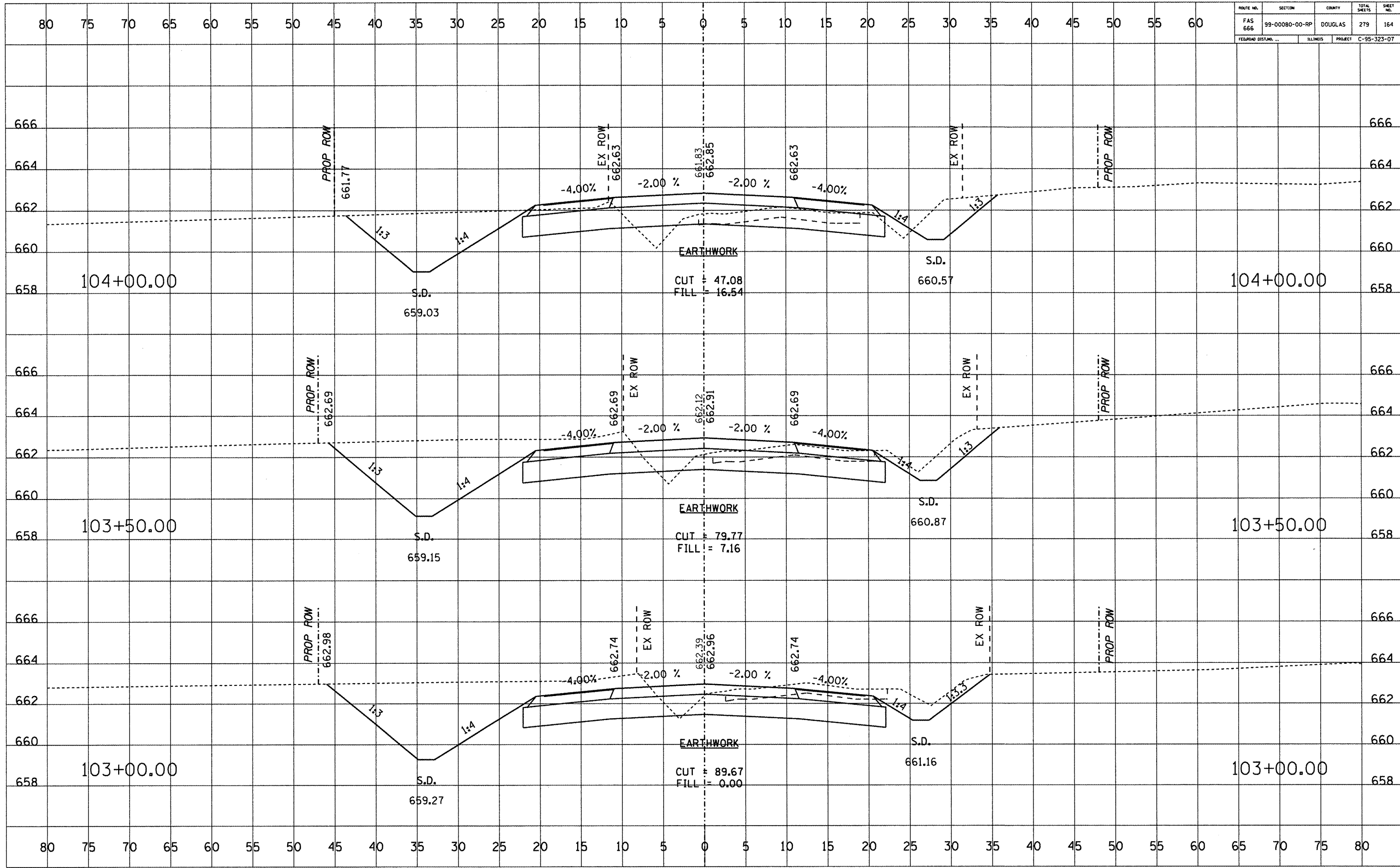



ROUTE NO.	SECTION	COUNTY	TOTAL SHEETS	SHEET NO.
FAS 666	99-00080-00-RP	DOUGLAS	279	165
FEDERAL DIST. NO.		ILLINOIS	PROJECT C-95-323-07	

DATE	BY

DATE	BY

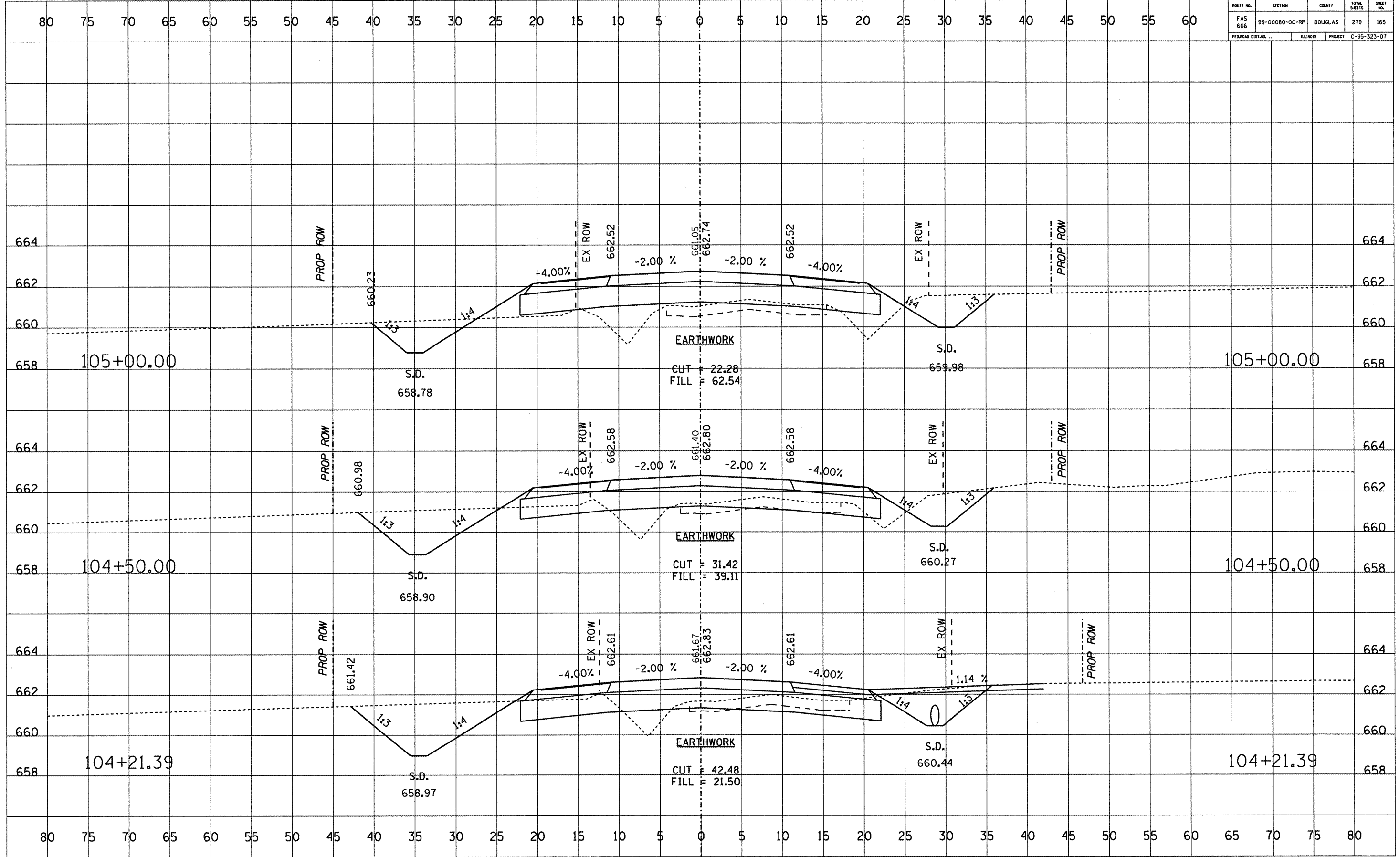

ROUTE NO.	SECTION	COUNTY	TOTAL SHEETS	SHEET NO.
FAS 666	99-00080-00-RP	DOUGLAS	279	166
FEDERAL DISTRICT		ILLINOIS	PROJECT C-95-323-07	

DATE	BY

DATE	BY

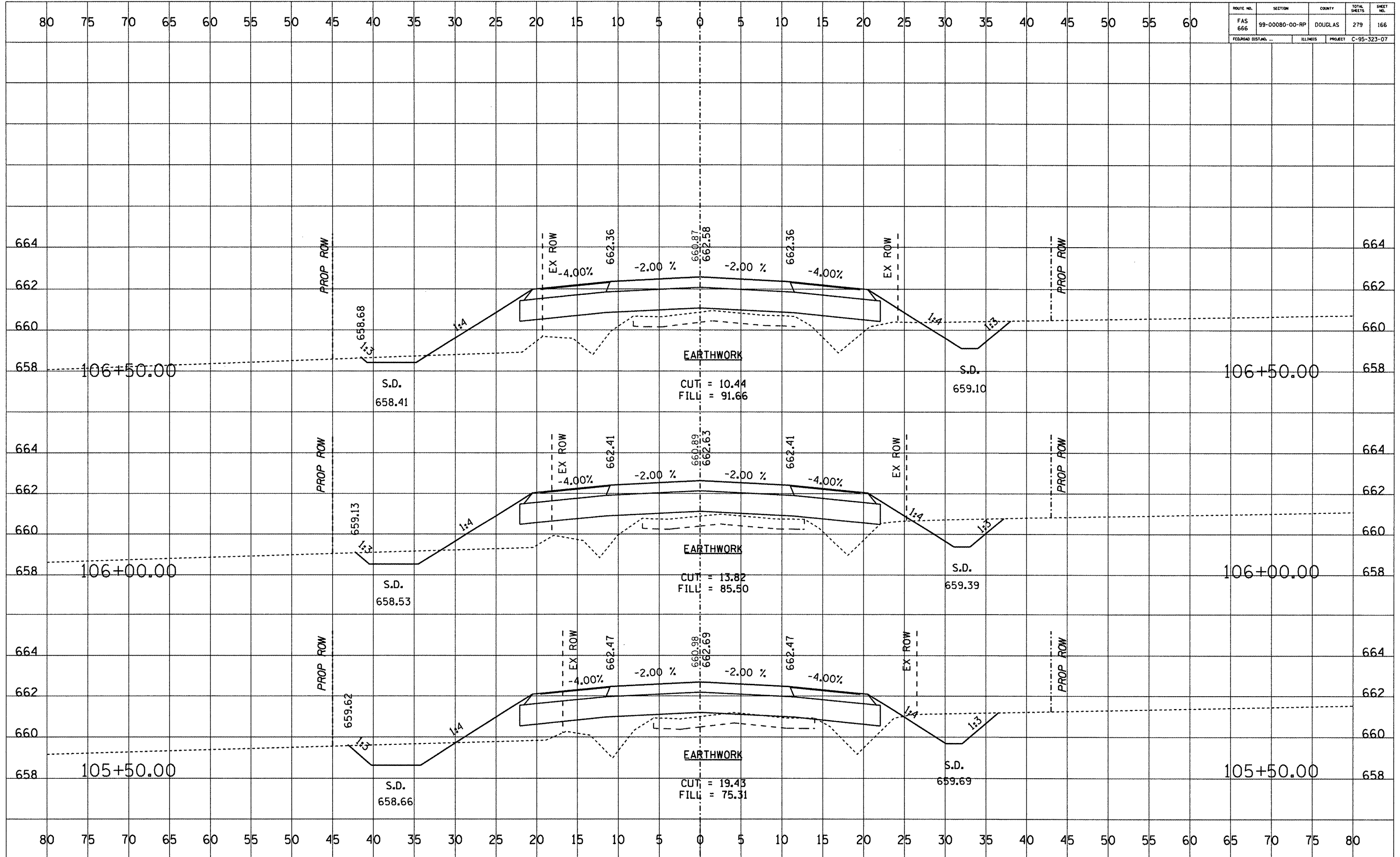

ROUTE NO.	SECTION	COUNTY	TOTAL SHEETS	SHEET NO.
FAS 666	99-00080-00-RP	DOUGLAS	279	167
FEDERAL DISTRICT		ILLINOIS	PROJECT C-95-323-07	

DATE	BY

DATE	BY

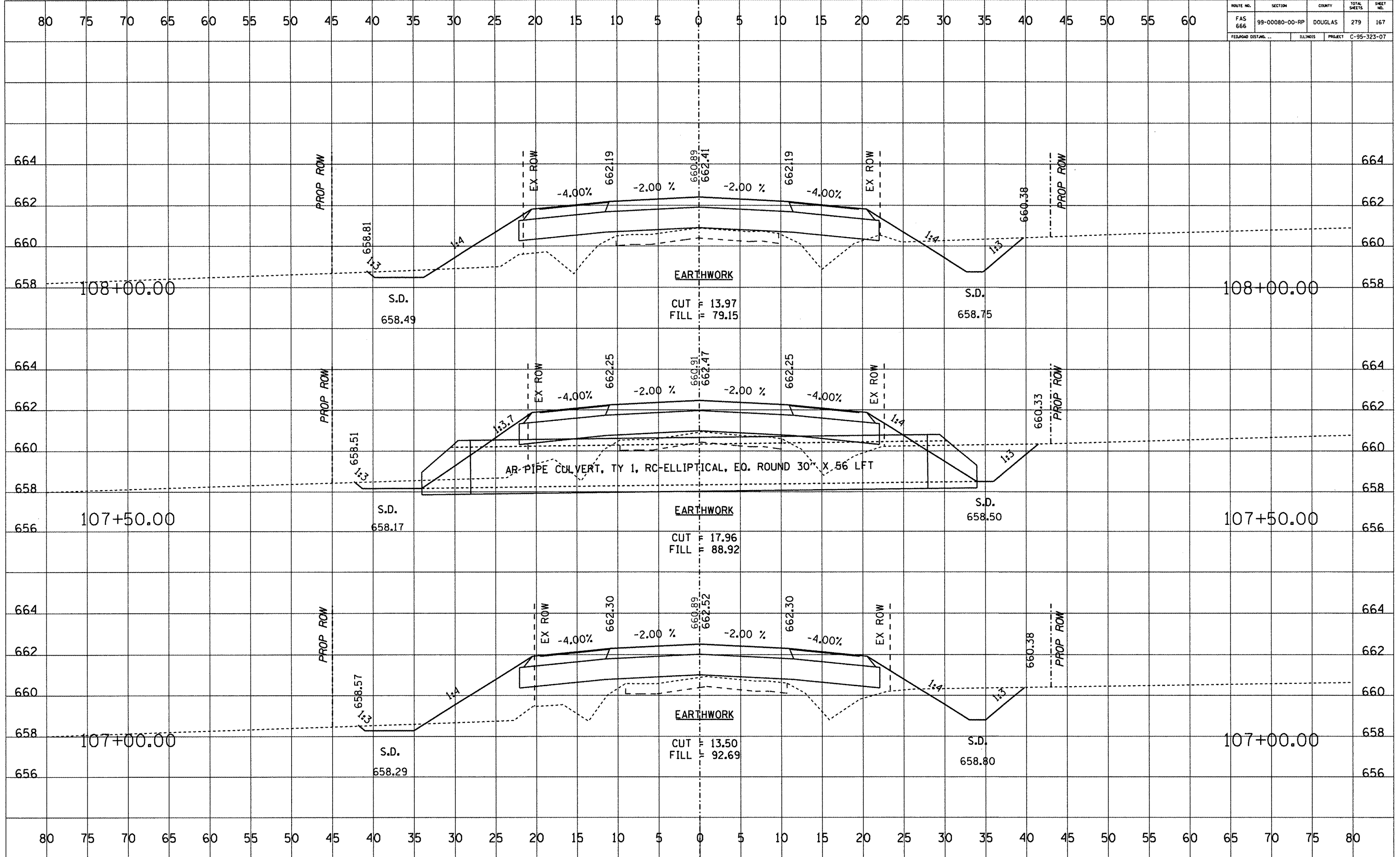

ROUTE NO.	SECTION	COUNTY	TOTAL SHEETS	SHEET NO.
FAS 666	99-00080-00-RP	DOUGLAS	279	168
FEDERAL DIST. NO. ...		ILLINOIS	PROJECT C-95-323-07	

DATE	BY

DATE	BY

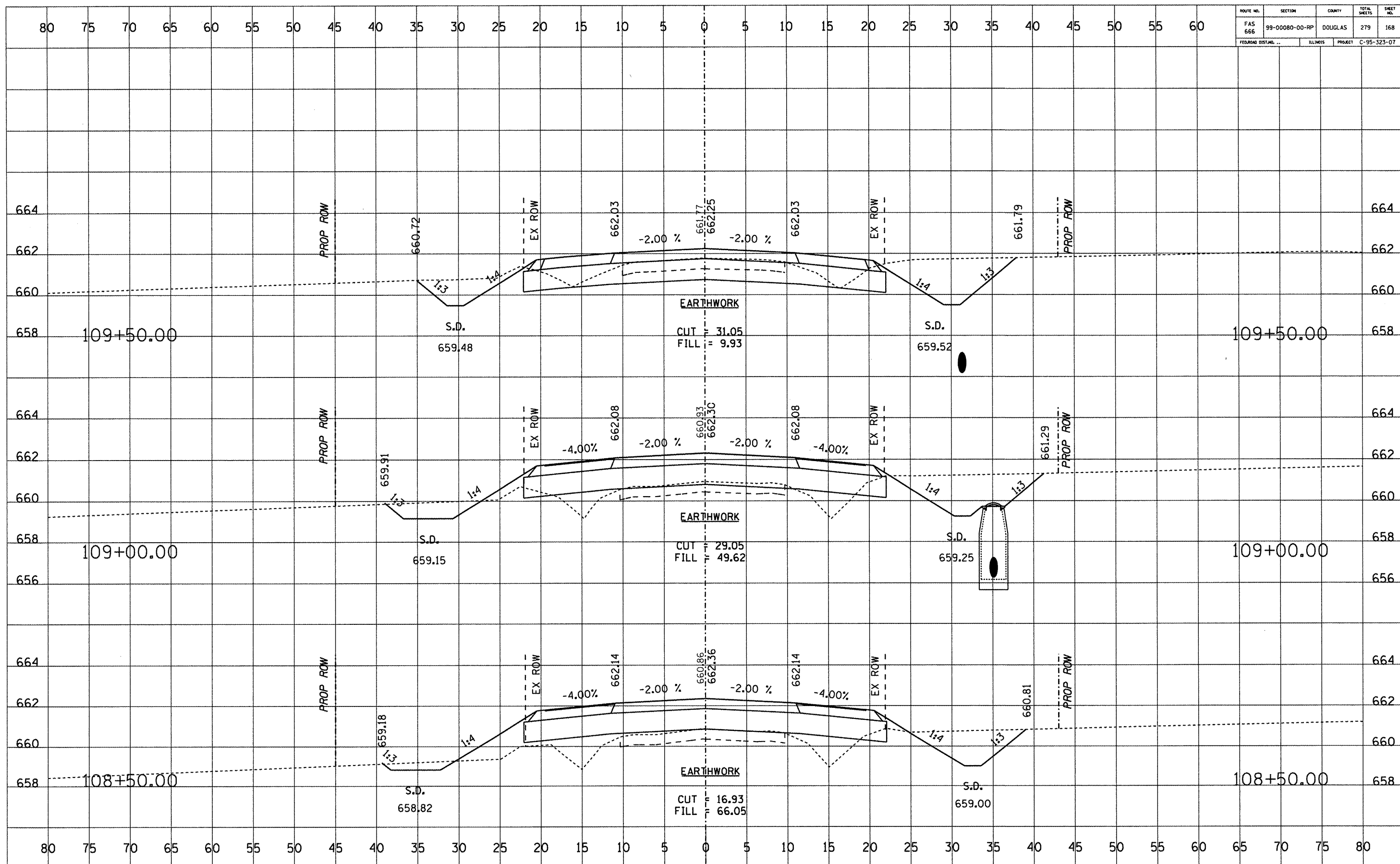

ROUTE NO.	SECTION	COUNTY	TOTAL SHEETS	SHEET NO.
FAS 666	99-00080-00-RP	DOUGLAS	279	169
FED. ROAD DIST. NO. ...		ILLINOIS	PROJECT C-95-323-07	

DATE	BY	REVISION

DATE	BY	REVISION

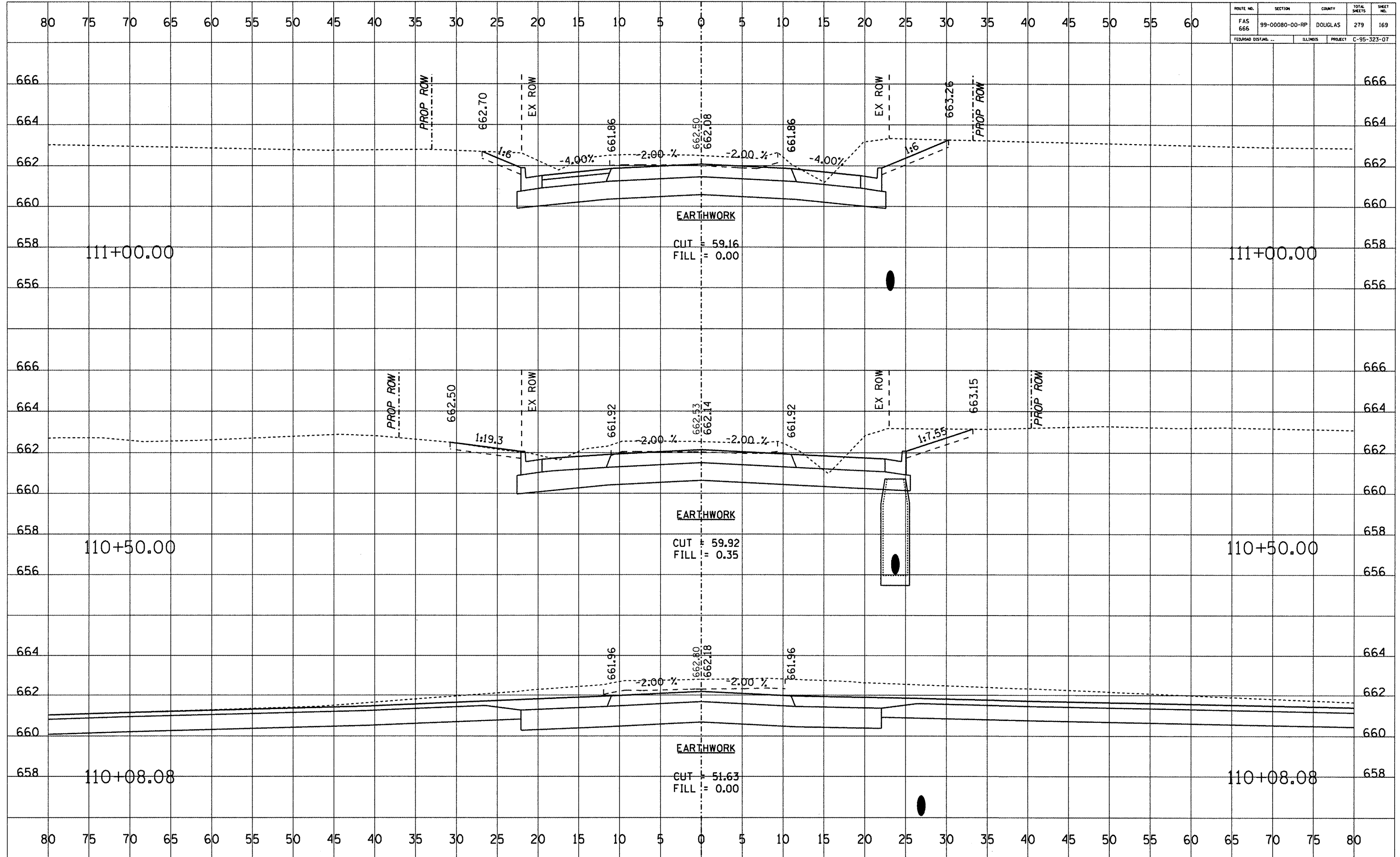

ROUTE NO.	SECTION	COUNTY	TOTAL SHEETS	SHEET NO.
FAS 666	99-00080-00-RP	DOUGLAS	279	170
FEDERAL DIST. NO. ...		ILLINOIS	PROJECT C-95-323-07	

DATE	
BY	
FINAL SURVEY	SURVEYED
NOTE BOOK NO.	PLOTTED
	TEMPLATE
	AREAS CHECKED

DATE	
BY	
ORIGINAL SURVEY	SURVEYED
NOTE BOOK NO.	PLOTTED
	TEMPLATE
	AREAS CHECKED

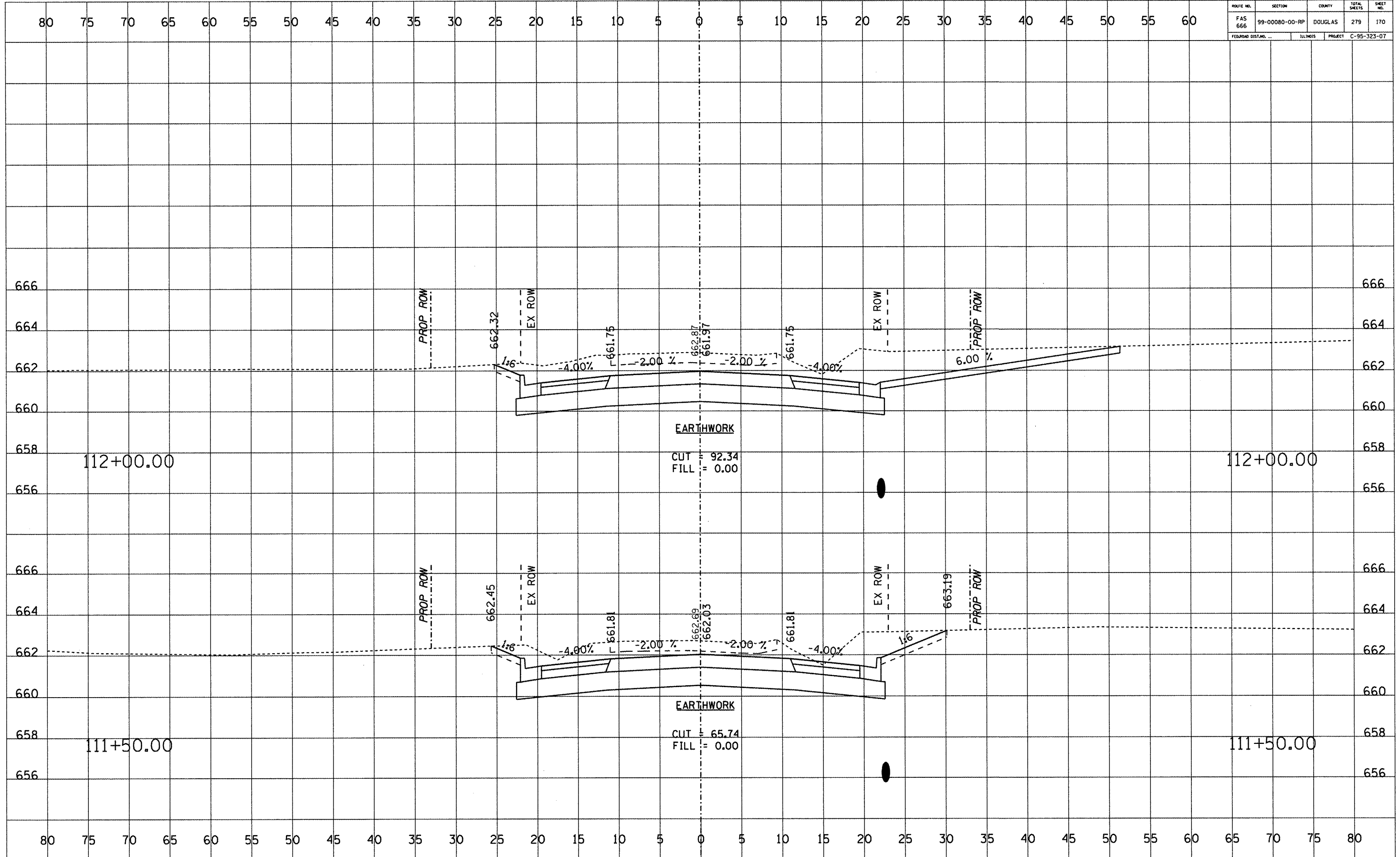

ROUTE NO.	SECTION	COUNTY	TOTAL SHEETS	SHEET NO.
FAS 666	99-00080-00-RP	DOUGLAS	279	171
FEDERAL DISTRICT		ILLINOIS	PROJECT C-95-323-07	

DATE	
BY	
NO.	
FINAL SURVEY	
NOTE BOOK	
PLOTTED	
TEMPLATE	
AREAS CHECKED	

DATE	
BY	
NO.	
ORIGINAL SURVEY	
NOTE BOOK	
PLOTTED	
TEMPLATE	
AREAS CHECKED	

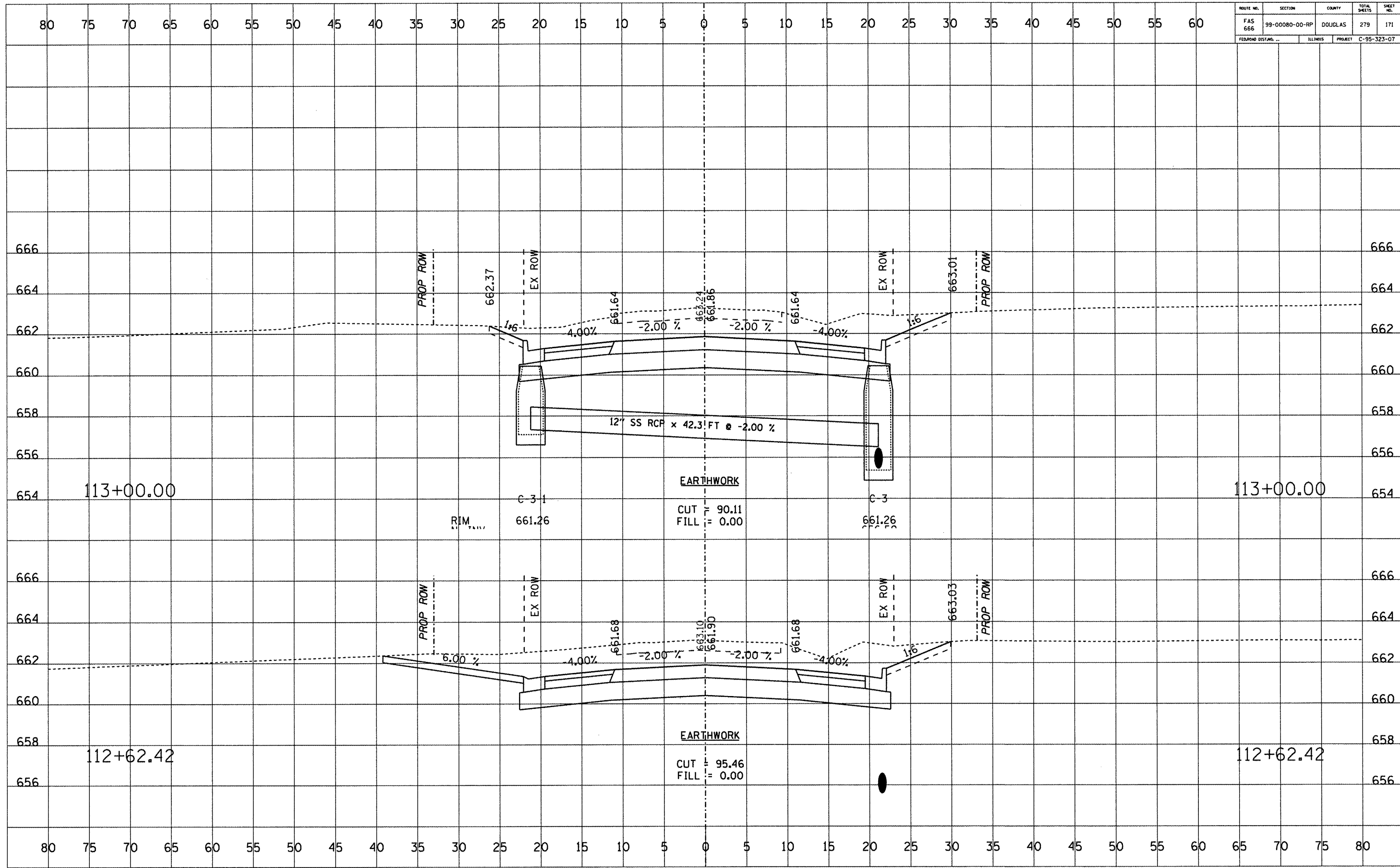

ROUTE NO.	SECTION	COUNTY	TOTAL SHEETS	SHEET NO.
FAS 666	99-00080-00-RP	DOUGLAS	279	172
FED. ROAD DIST. NO.	ILLINOIS	PROJECT	C-95-323-07	

80 75 70 65 60 55 50 45 40 35 30 25 20 15 10 5 0 5 10 15 20 25 30 35 40 45 50 55 60

DATE	BY

NO.	AREAS CHECKED	REMARKS	DATE

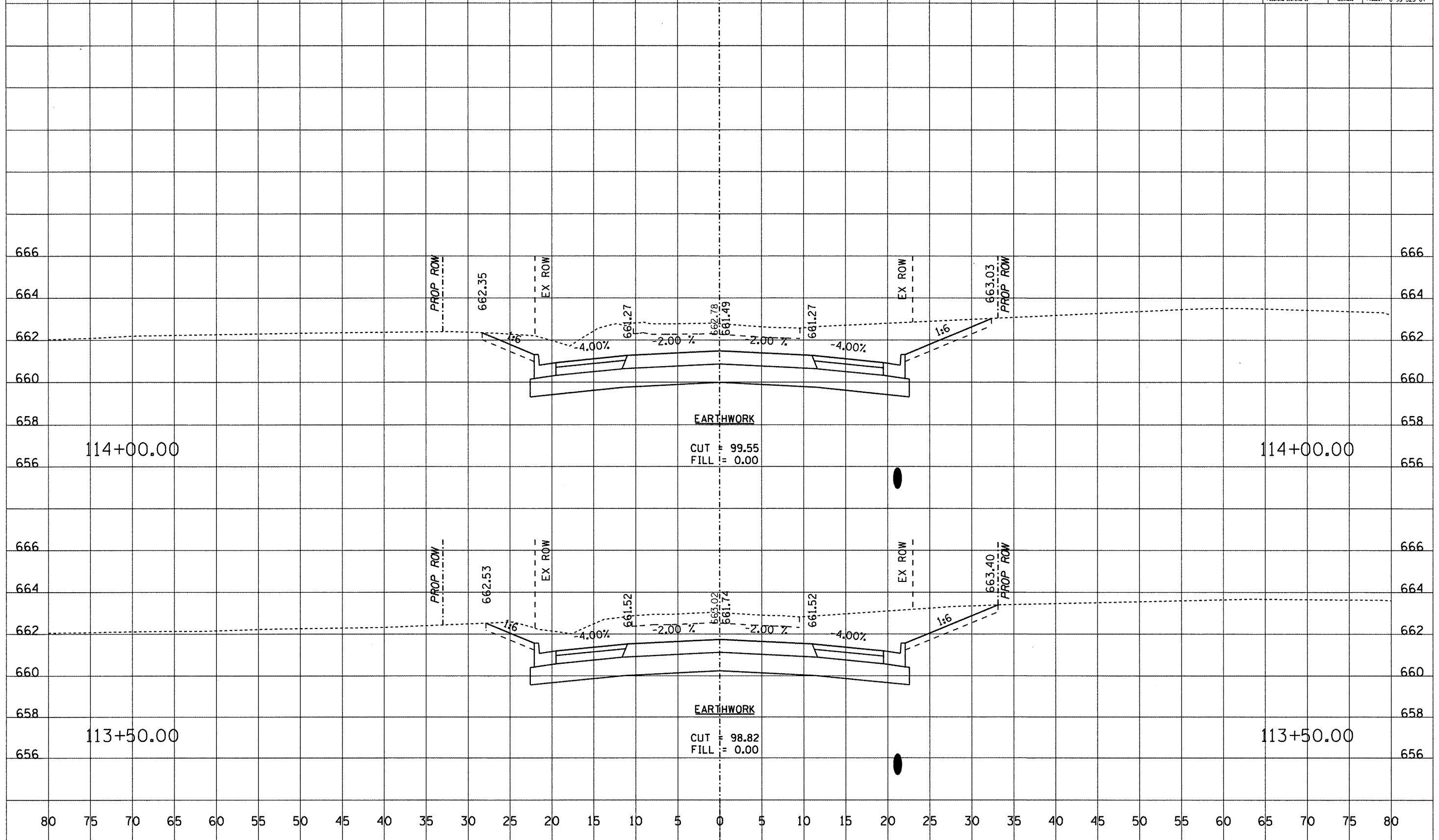

DATE	BY

NO.	AREAS CHECKED	REMARKS	DATE



ROUTE NO.	SECTION	COUNTY	TOTAL SHEETS	SHEET NO.
FAS 666	99-00080-00-RP	DOUGLAS	279	173
FEDERAL DIST. NO.		ILLINOIS	PROJECT	C-95-323-07

DATE	BY

DATE	BY

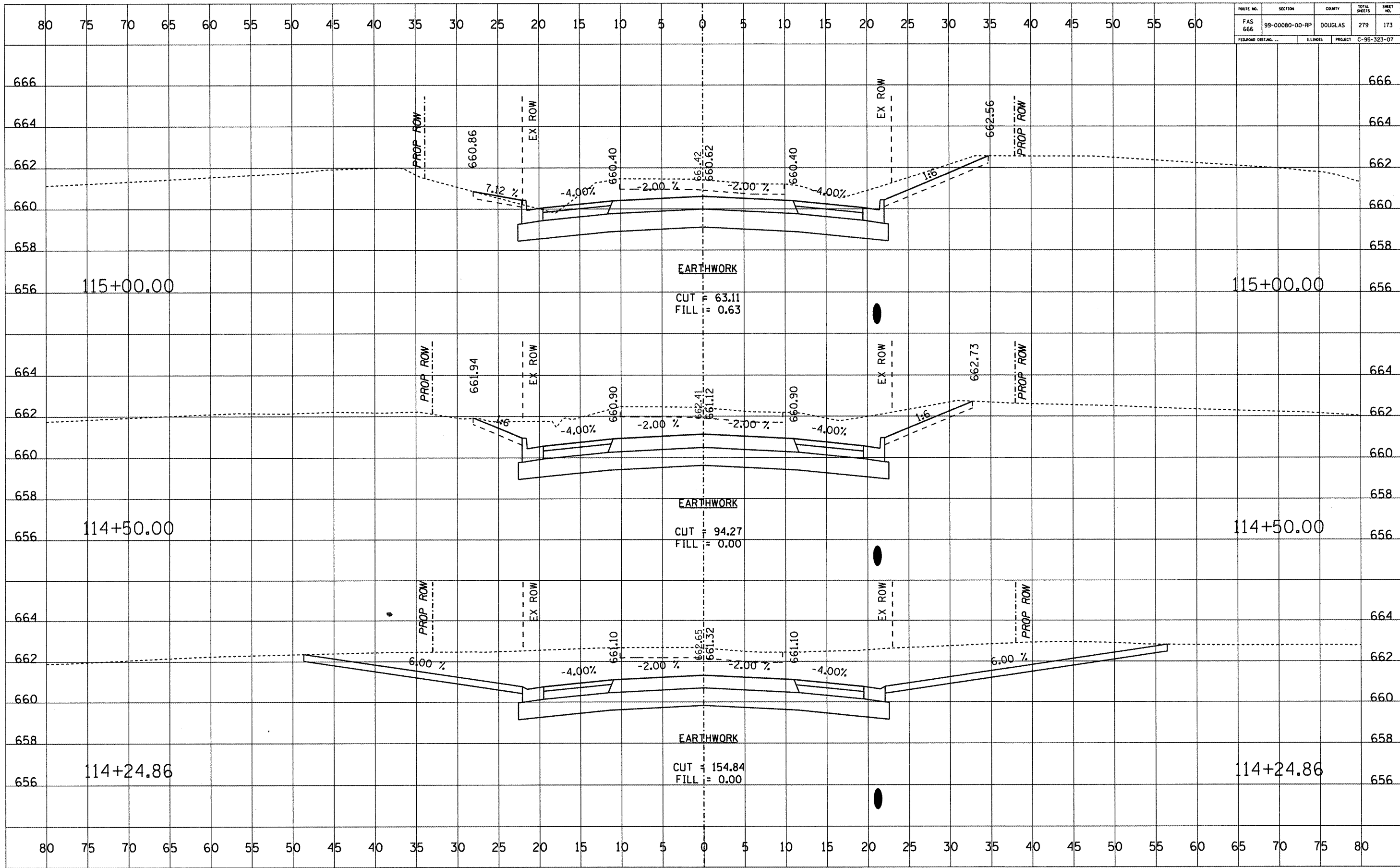

ROUTE NO.	SECTION	COUNTY	TOTAL SHEETS	SHEET NO.
FAS 666	99-00080-00-RP	DOUGLAS	279	174
FEDERAL DIST. NO. ...		ILLINOIS	PROJECT C-95-323-07	

DATE	
BY	
REVISIONS	
SURVEY	
PLOTTED	
TEMPLATE	
NOTE BOOK	
NO.	
AREAS CHECKED	

DATE	
BY	
REVISIONS	
SURVEY	
PLOTTED	
TEMPLATE	
NOTE BOOK	
NO.	
AREAS CHECKED	

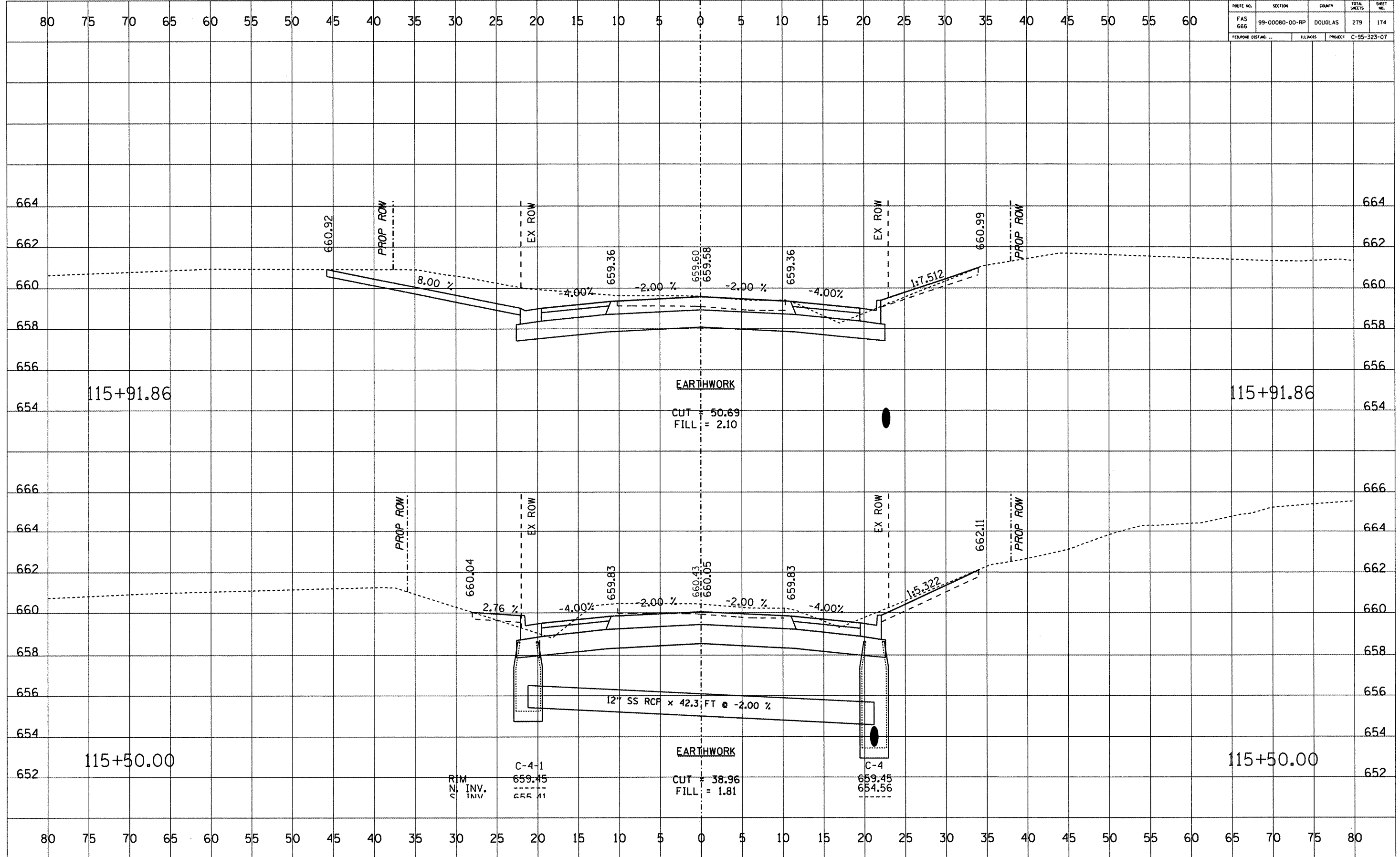

ROUTE NO.	SECTION	COUNTY	TOTAL SHEETS	SHEET NO.
FAS 666	99-00080-00-RP	DOUGLAS	279	175
FEDERAL DIST. NO. ...		ILLINOIS	PROJECT C-95-323-07	

DATE	BY

DATE	BY

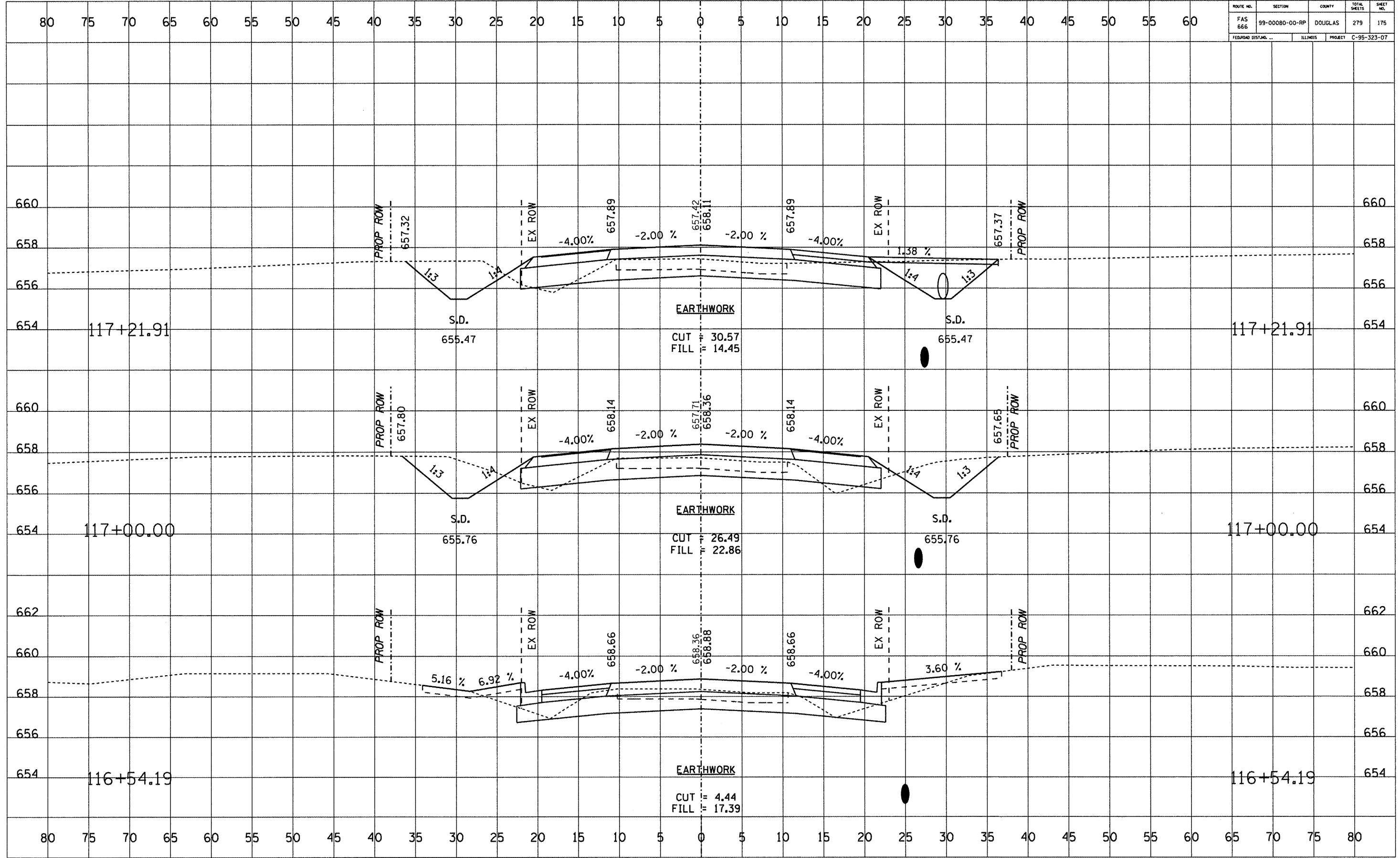

**EARTHWORK**  
 CUT = 30.57  
 FILL = 14.45

**EARTHWORK**  
 CUT = 26.49  
 FILL = 22.86

**EARTHWORK**  
 CUT = 4.44  
 FILL = 17.39

ROUTE NO.	SECTION	COUNTY	TOTAL SHEETS	SHEET NO.
FAS 666	99-00080-00-RP	DOUGLAS	279	176
ROAD DISTANCE		ILLINOIS	PROJECT	C-95-323-07

DATE	
BY	
APPROVED	
PLOTTED	
TEMPLATE	
NOTE BOOK	
AREAS CHECKED	
NO.	

DATE	
BY	
APPROVED	
PLOTTED	
TEMPLATE	
NOTE BOOK	
AREAS CHECKED	
NO.	

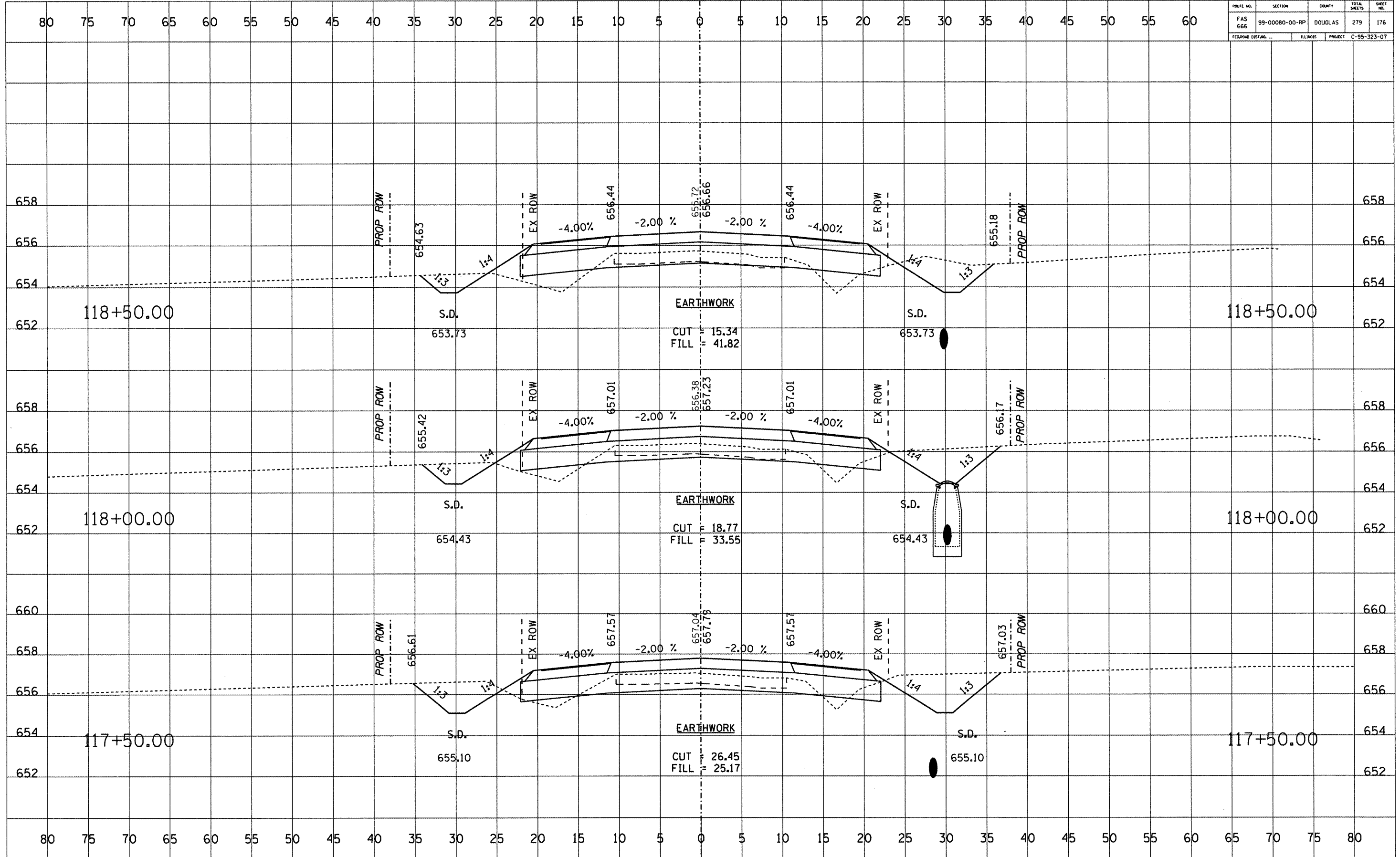

ROUTE NO.	SECTION	COUNTY	TOTAL SHEETS	SHEET NO.
FAS 666	99-00080-00-RP	DOUGLAS	279	177
FEDERAL DIST. NO.		ILLINOIS	PROJECT C-95-323-07	

DATE	BY

DATE	BY

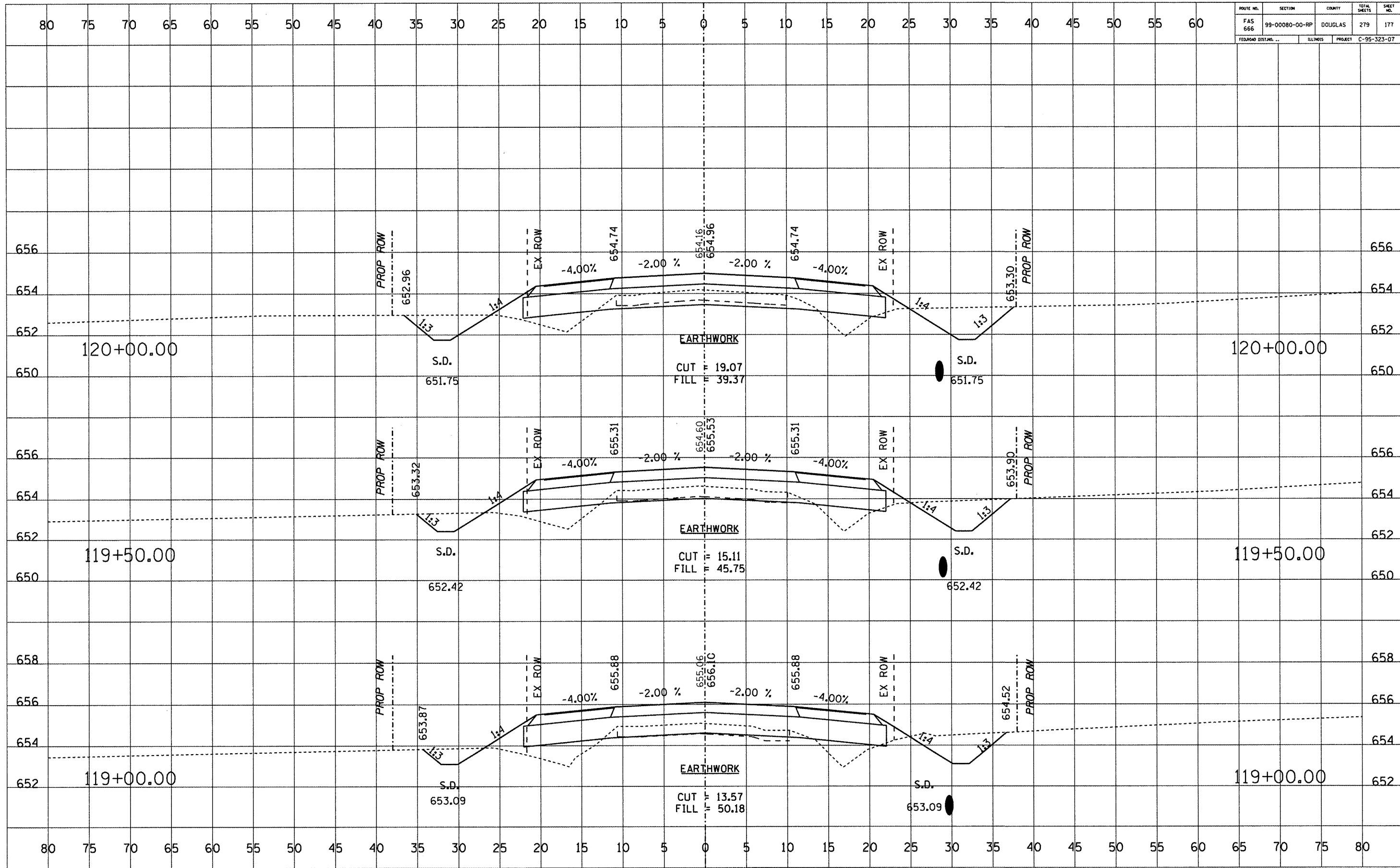

ROUTE NO.	SECTION	COUNTY	TOTAL SHEETS	SHEET NO.
FAS 666	99-00080-00-RP	DOUGLAS	279	178
FEDORAD DIST. NO. ...		ILLINOIS	PROJECT C-95-323-07	

DATE	
BY	
FINAL SURVEY	
PLOTTED	
NOTE BOOK	
AREAS CHECKED	

DATE	
BY	
ORIGINAL SURVEY	
PLOTTED	
NOTE BOOK	
AREAS CHECKED	

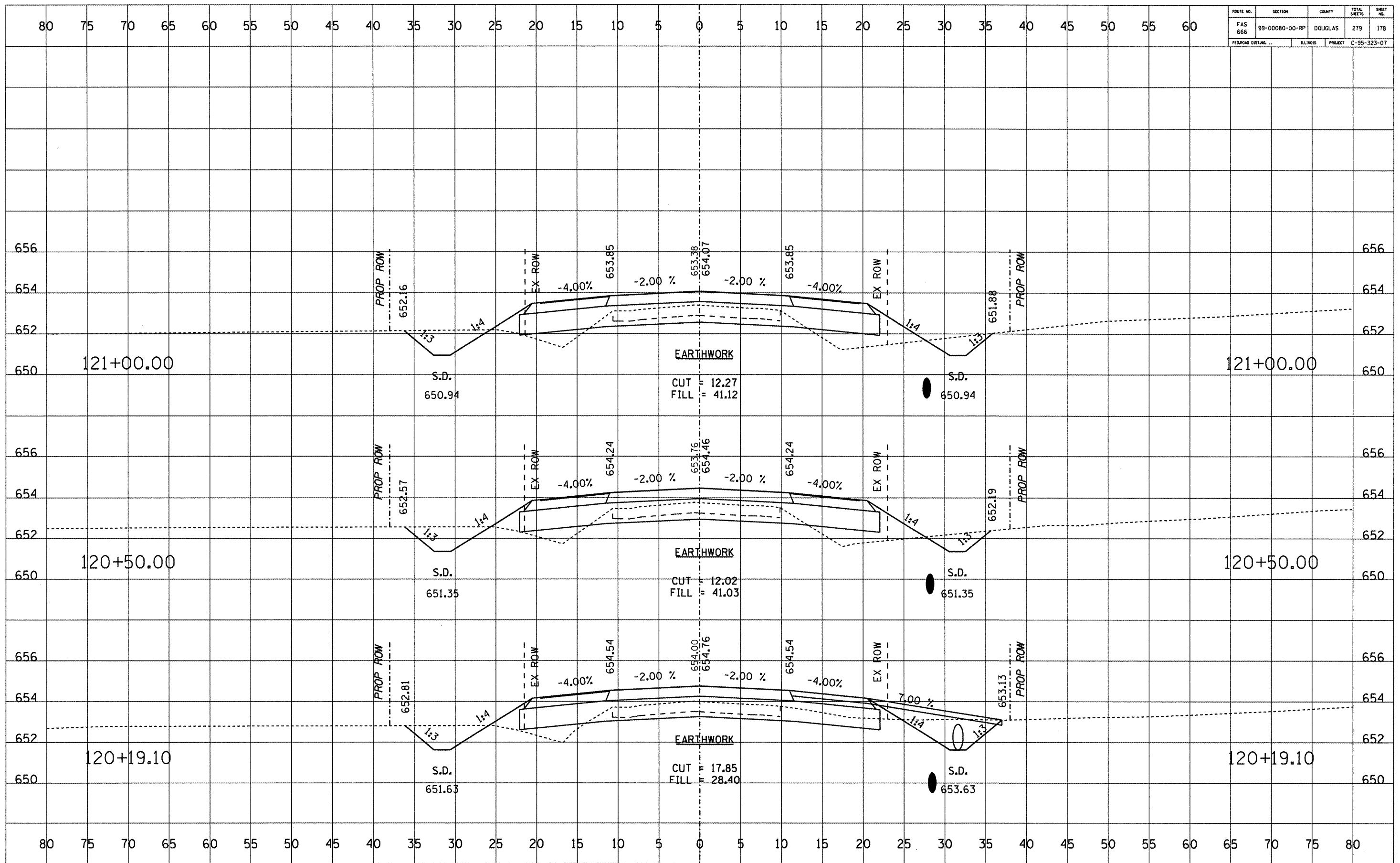

ROUTE NO.	SECTION	COUNTY	TOTAL SHEETS	SHEET NO.
FAS 666	99-00080-00-RP	DOUGLAS	279	179
FED. ROAD DIST. NO.	ILLINOIS	PROJECT	C-95-323-07	

DATE	BY	REVISION

DATE	BY	REVISION

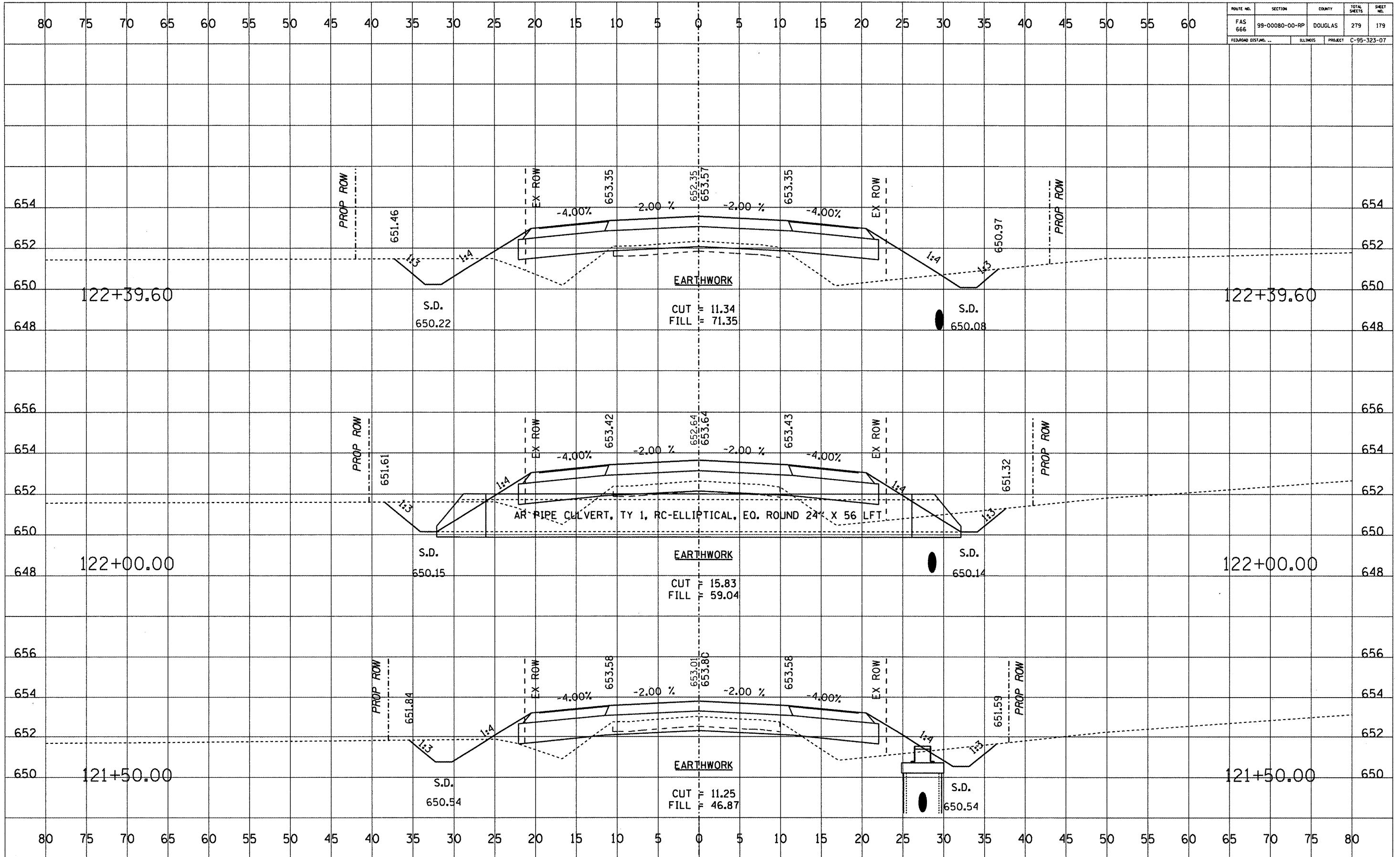







ROUTE NO.	SECTION	COUNTY	TOTAL SHEETS	SHEET NO.
FAS 666	99-00080-00-RP	DOUGLAS	279	182
FEDERAL DISTRICT		ILLINOIS	PROJECT C-95-323-07	

DATE	BY

DATE	BY

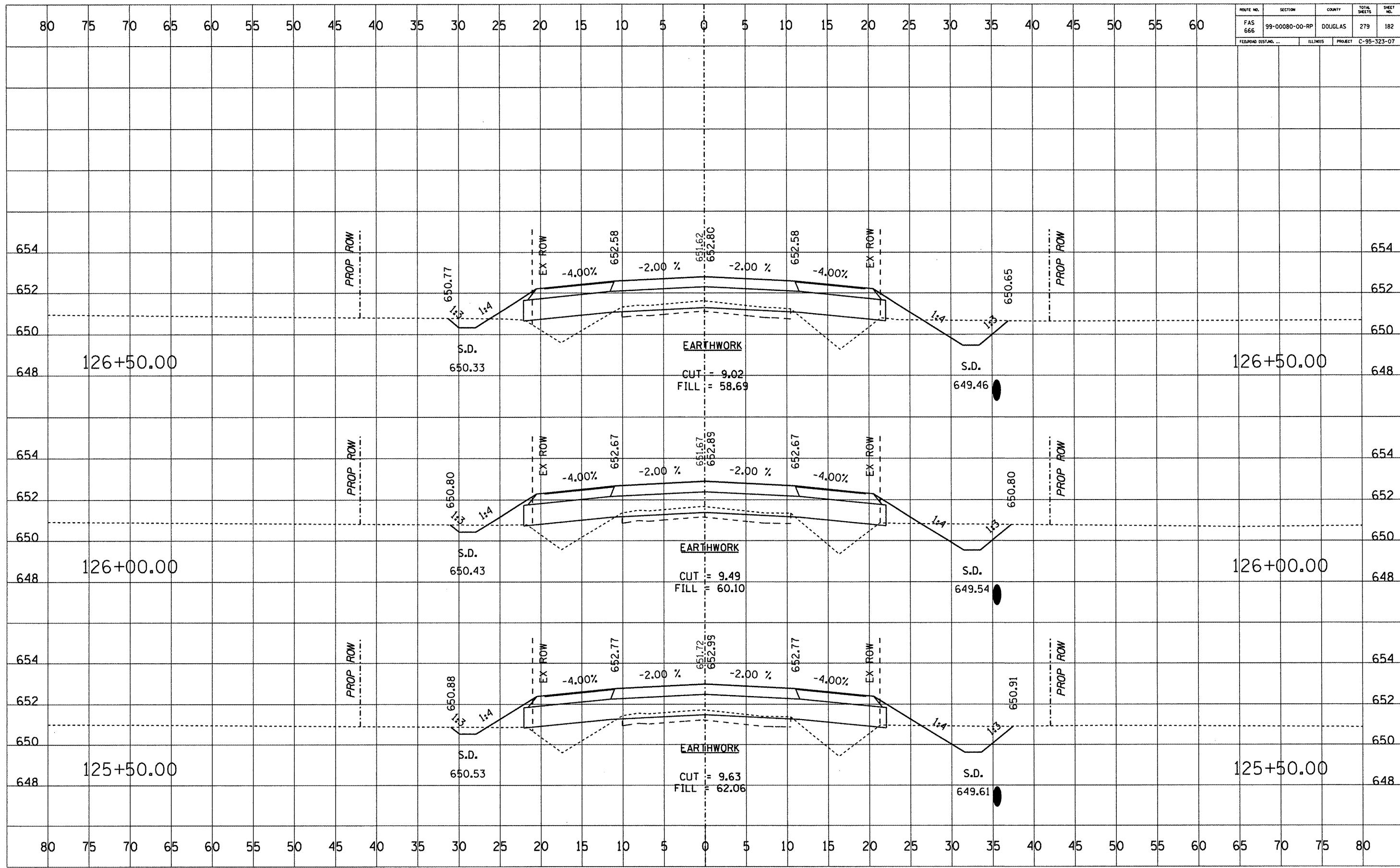

ROUTE NO.	SECTION	COUNTY	TOTAL SHEETS	SHEET NO.
FAS 666	99-00080-00-RP	DOUGLAS	279	183
FEDERAL DIST. NO.	ILLINOIS	PROJECT	C-95-323-07	

DATE	BY

DATE	BY

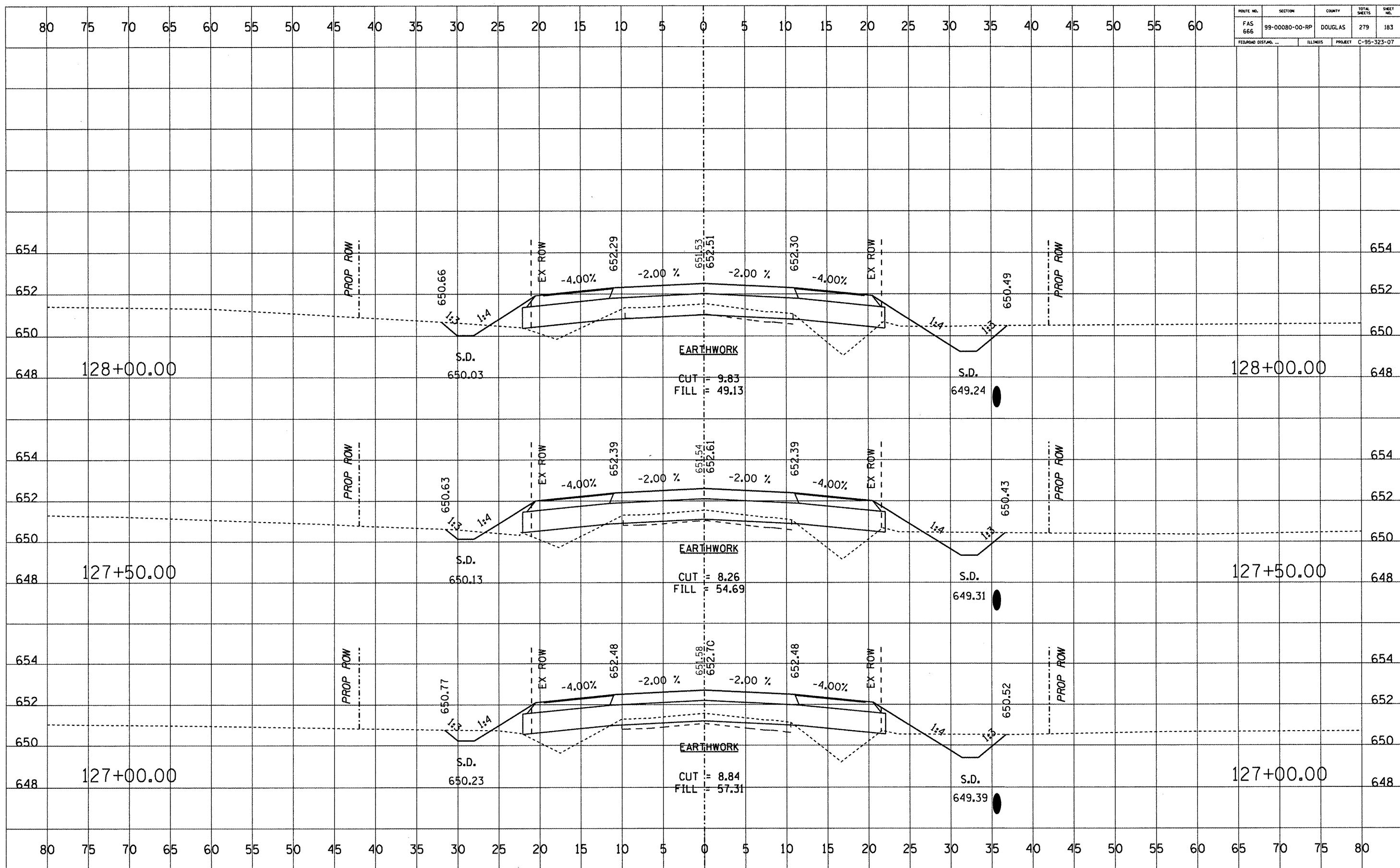

ROUTE NO.	SECTION	COUNTY	TOTAL SHEETS	SHEET NO.
FAS 666	99-00080-00-RP	DOUGLAS	279	184
FEDORAD DIST. NO. ...		ILLINOIS	PROJECT C-95-323-07	

DATE	BY

DATE	BY

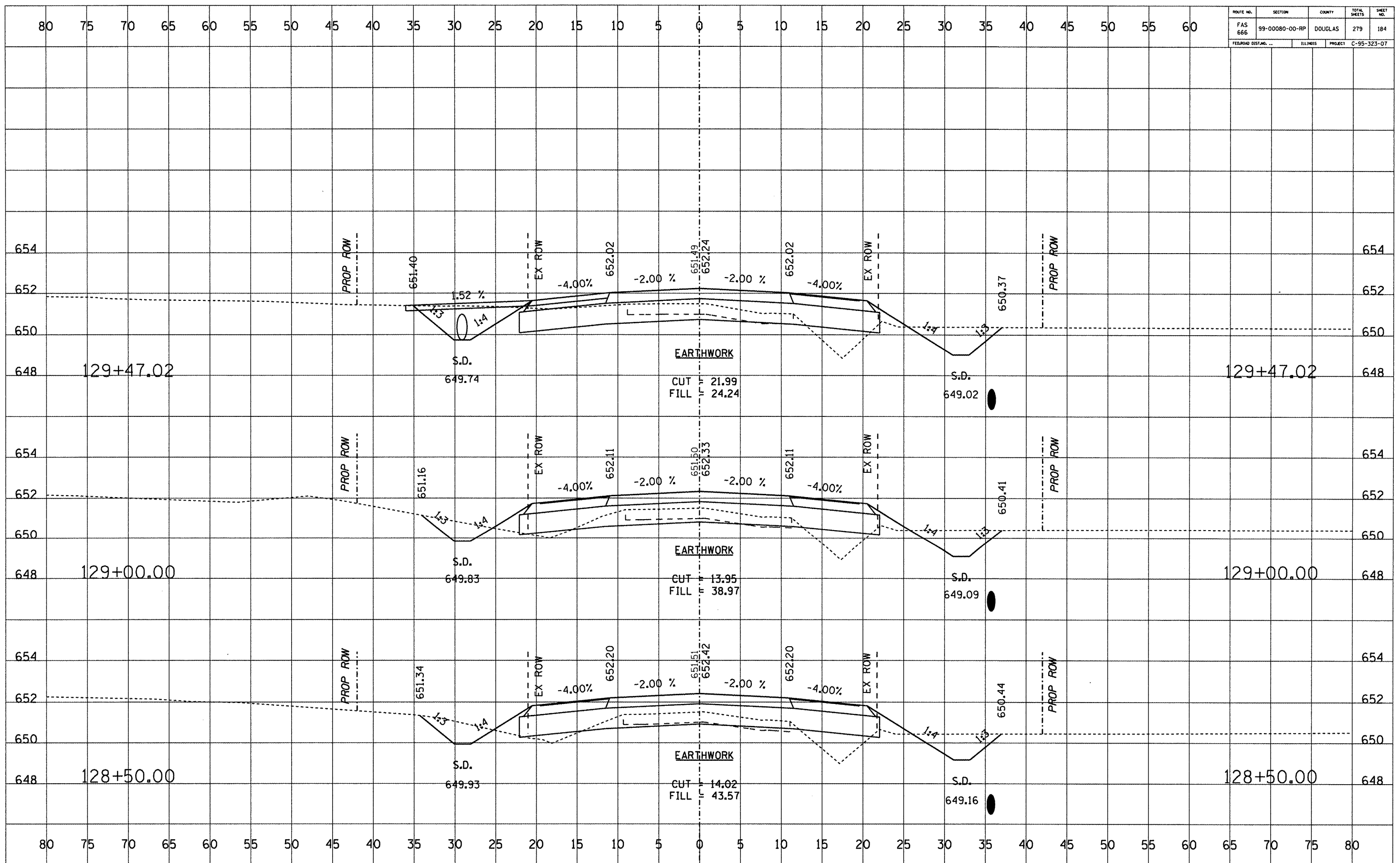

ROUTE NO.	SECTION	COUNTY	TOTAL SHEETS	SHEET NO.
FAS 666	99-00080-00-RP	DOUGLAS	279	185
FEDERAL DIST. NO. ...		ILLINOIS	PROJECT C-95-323-07	

FINAL SURVEY	DATE
SURVEYED	
PLOTTED	
REPLATE	
NOTE BOOK	
AREAS CHECKED	
NO.	

ORIGINAL SURVEY	DATE
SURVEYED	
PLOTTED	
REPLATE	
NOTE BOOK	
AREAS CHECKED	
NO.	

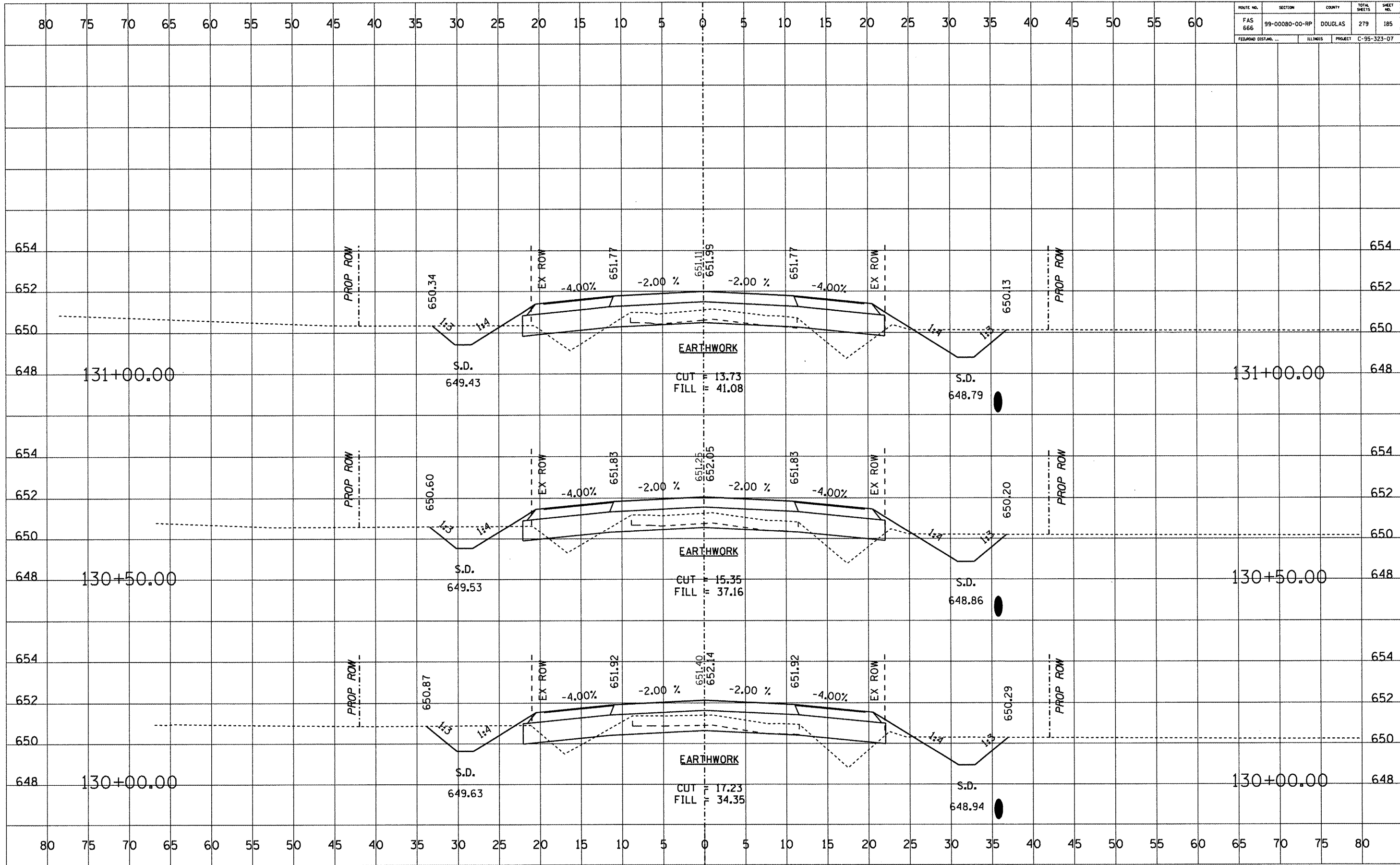



ROUTE NO.	SECTION	COUNTY	TOTAL SHEETS	SHEET NO.
FAS 666	99-00080-00-RP	DOUGLAS	279	187
FEDERAL DIST. NO.		ILLINOIS	PROJECT C-95-323-07	

DATE	BY	SURVEYED	PLOTTED	TEMPLATE	NO. BOOK	AREAS CHECKED

DATE	BY	SURVEYED	PLOTTED	TEMPLATE	NO. BOOK	AREAS CHECKED

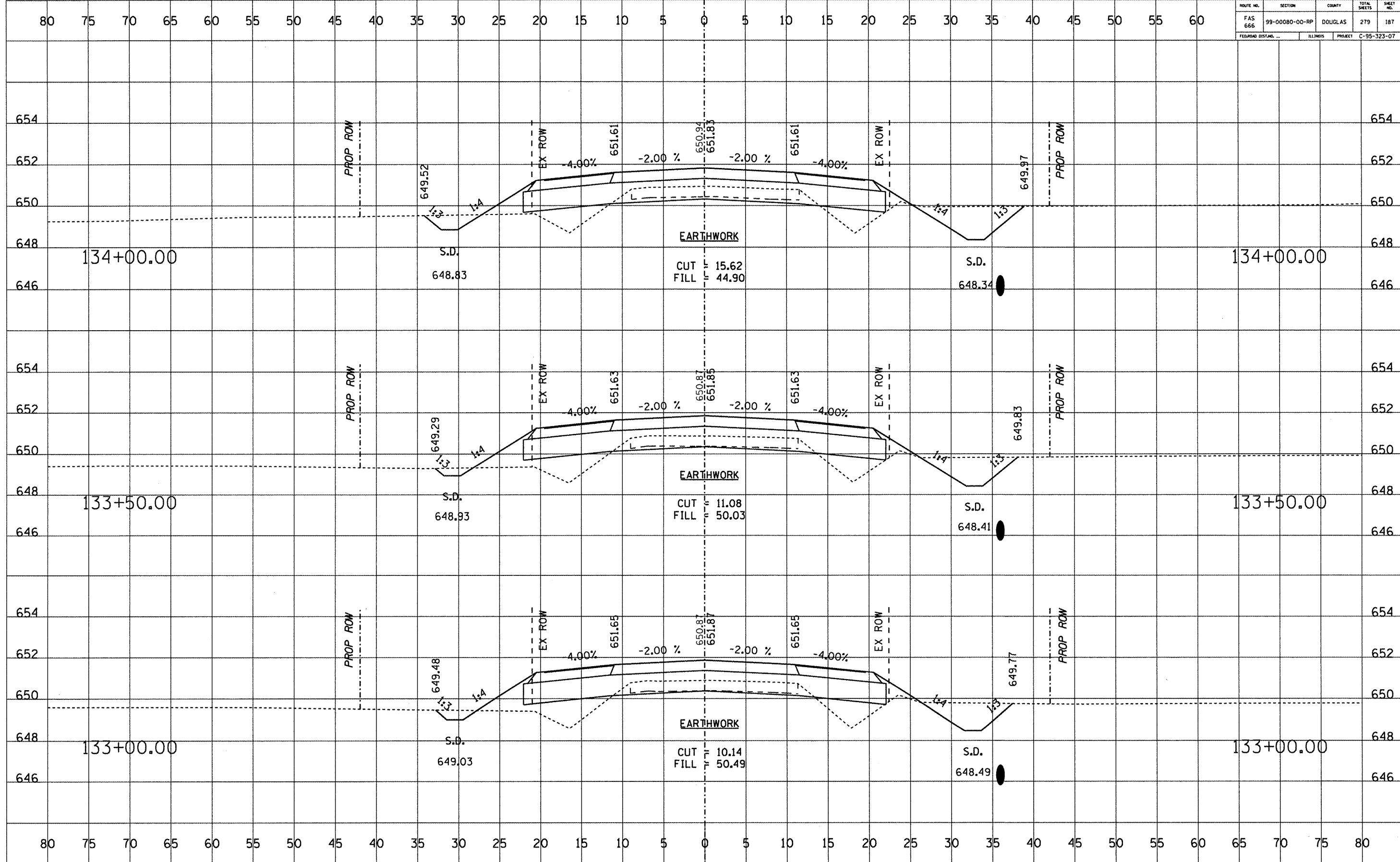

ROUTE NO.	SECTION	COUNTY	TOTAL SHEETS	SHEET NO.
FAS 666	99-00080-00-RP	DOUGLAS	279	188
FEDERAL DISTRICT ...		ILLINOIS	PROJECT C-95-323-07	

DATE	BY

  

FINAL SURVEY	REVISIONS	DATE
NOTE BOOK NO.	PLOTTED	
	TEMPLATE	
	AREAS CHECKED	

DATE	BY

ORIGINAL SURVEY	REVISIONS	DATE
NOTE BOOK NO.	PLOTTED	
	TEMPLATE	
	AREAS CHECKED	



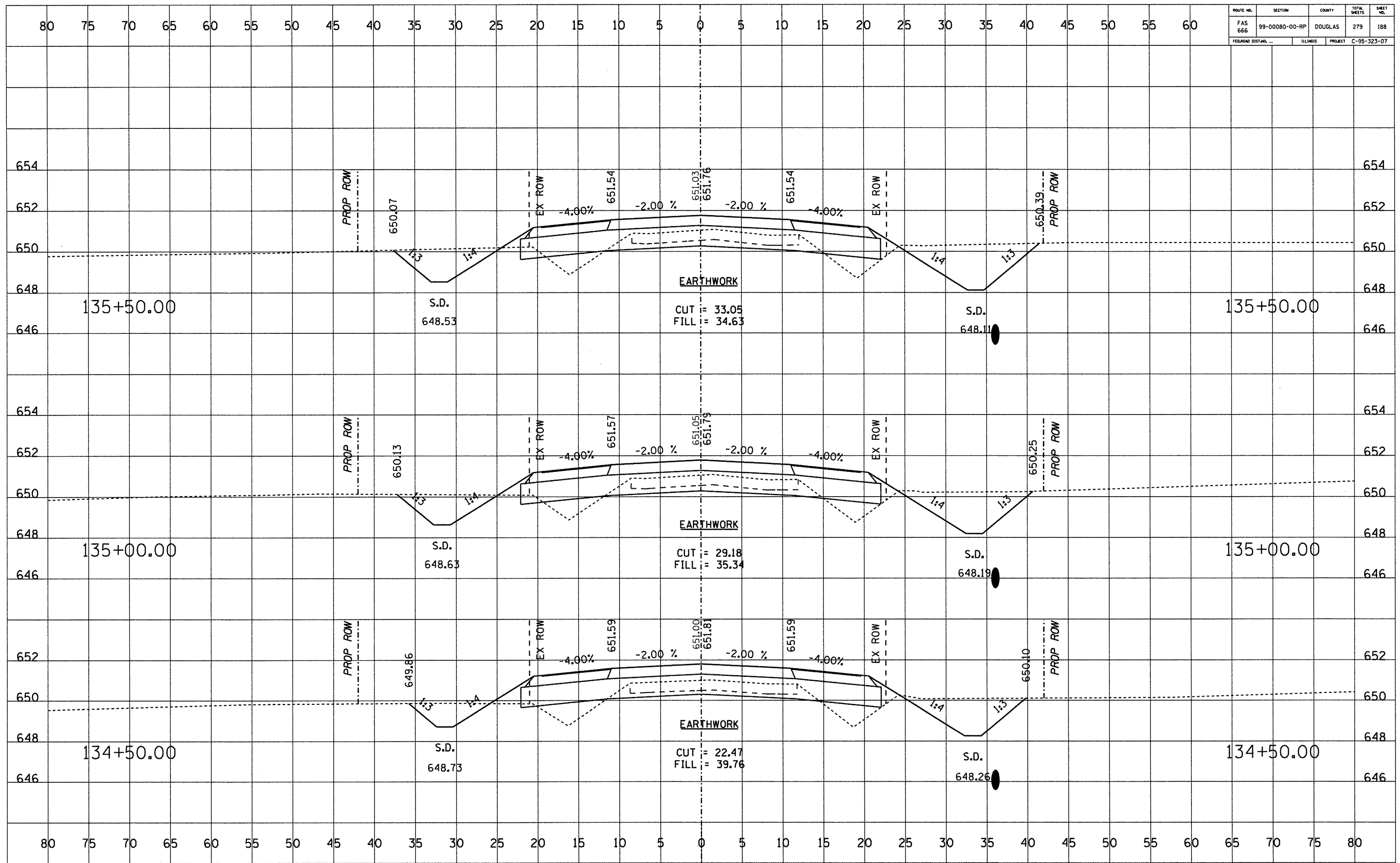

ROUTE NO.	SECTION	COUNTY	TOTAL SHEETS	SHEET NO.
FAS 666	99-00080-00-RP	DOUGLAS	279	189
FEDERAL DIST. NO.		ILLINOIS	PROJECT C-95-323-07	

DATE	
BY	
FINAL SURVEY	
NOTED	
TEMPLATE	
NO. BOOK	
AREAS CHECKED	

DATE	
BY	
ORIGINAL SURVEY	
NOTED	
TEMPLATE	
NO. BOOK	
AREAS CHECKED	

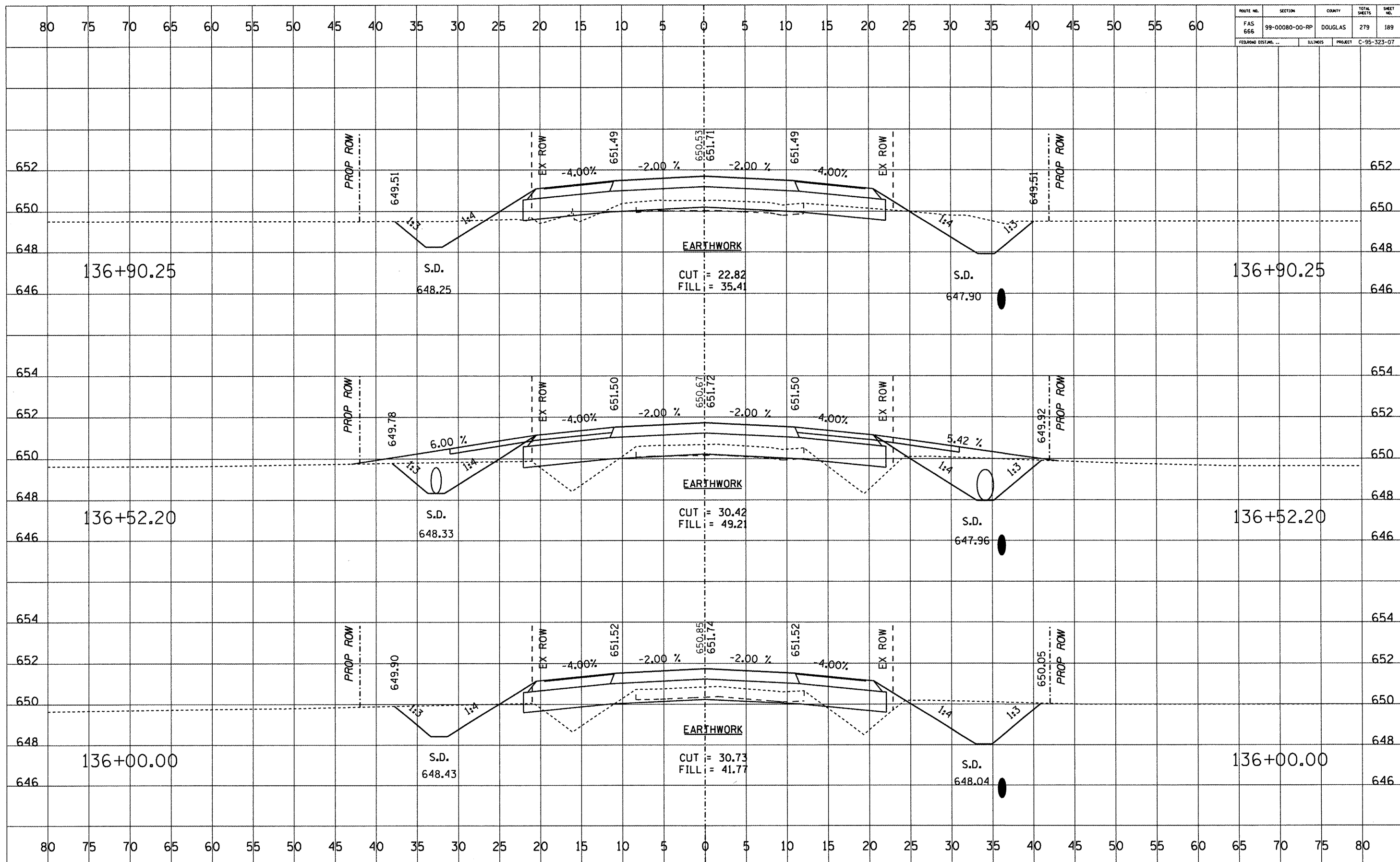

ROUTE NO.	SECTION	COUNTY	TOTAL SHEETS	SHEET NO.
FAS 666	99-00080-00-RP	DOUGLAS	279	190
FED/ROAD DISTRICT	ILLINOIS	PROJECT	C-95-323-07	

DATE	BY

DATE	BY

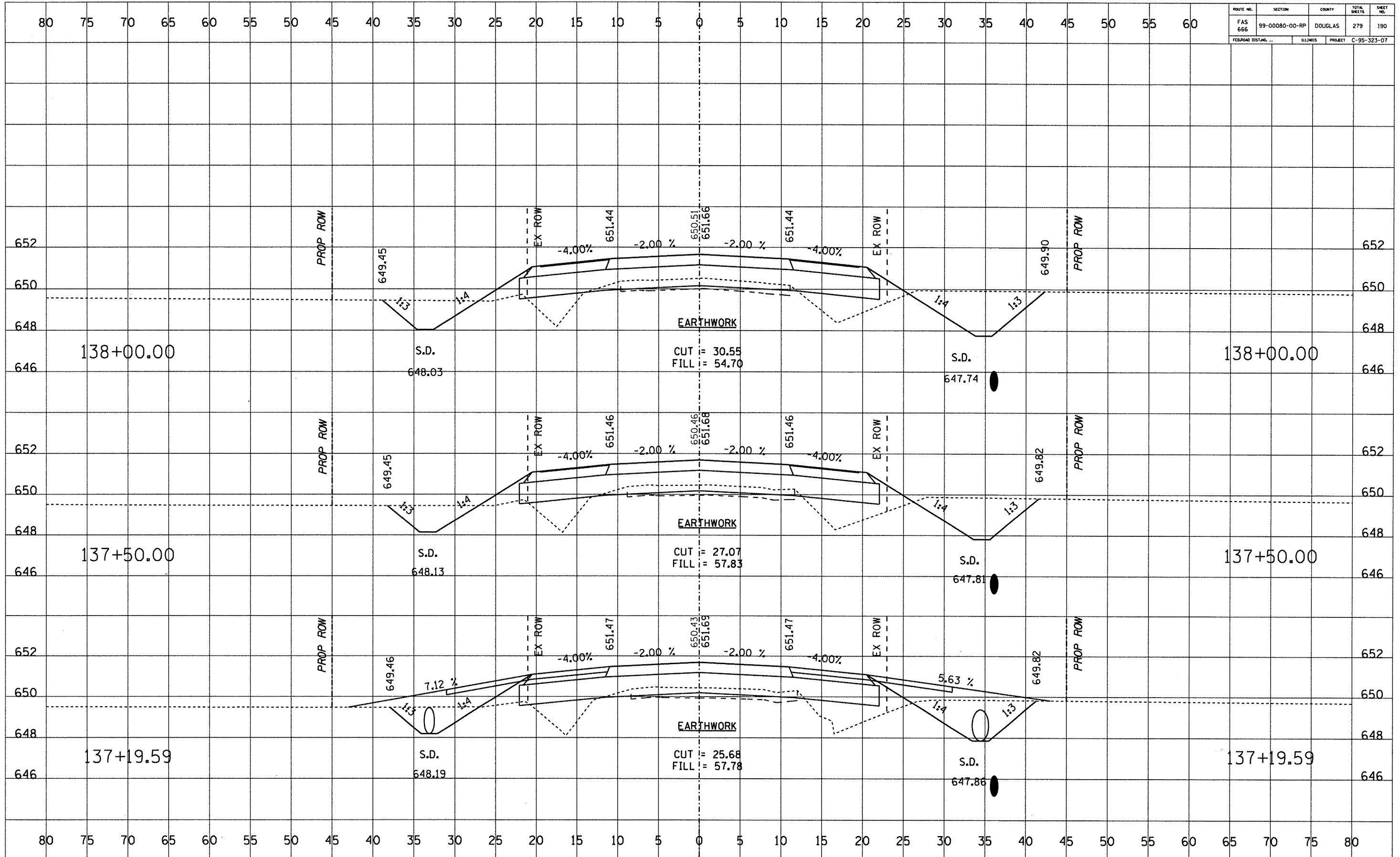

ROUTE NO.	SECTION	COUNTY	TOTAL SHEETS	SHEET NO.
FAS 666	99-00080-00-RP	DOUGLAS	279	191
FED. ROAD DIST. NO.		ILLINOIS	PROJECT	C-95-323-07

DATE	
BY	
FINAL SURVEY	
NOTED BOOK	
NO.	
AREAS CHECKED	

DATE	
BY	
ORIGINAL SURVEY	
NOTED BOOK	
NO.	
AREAS CHECKED	

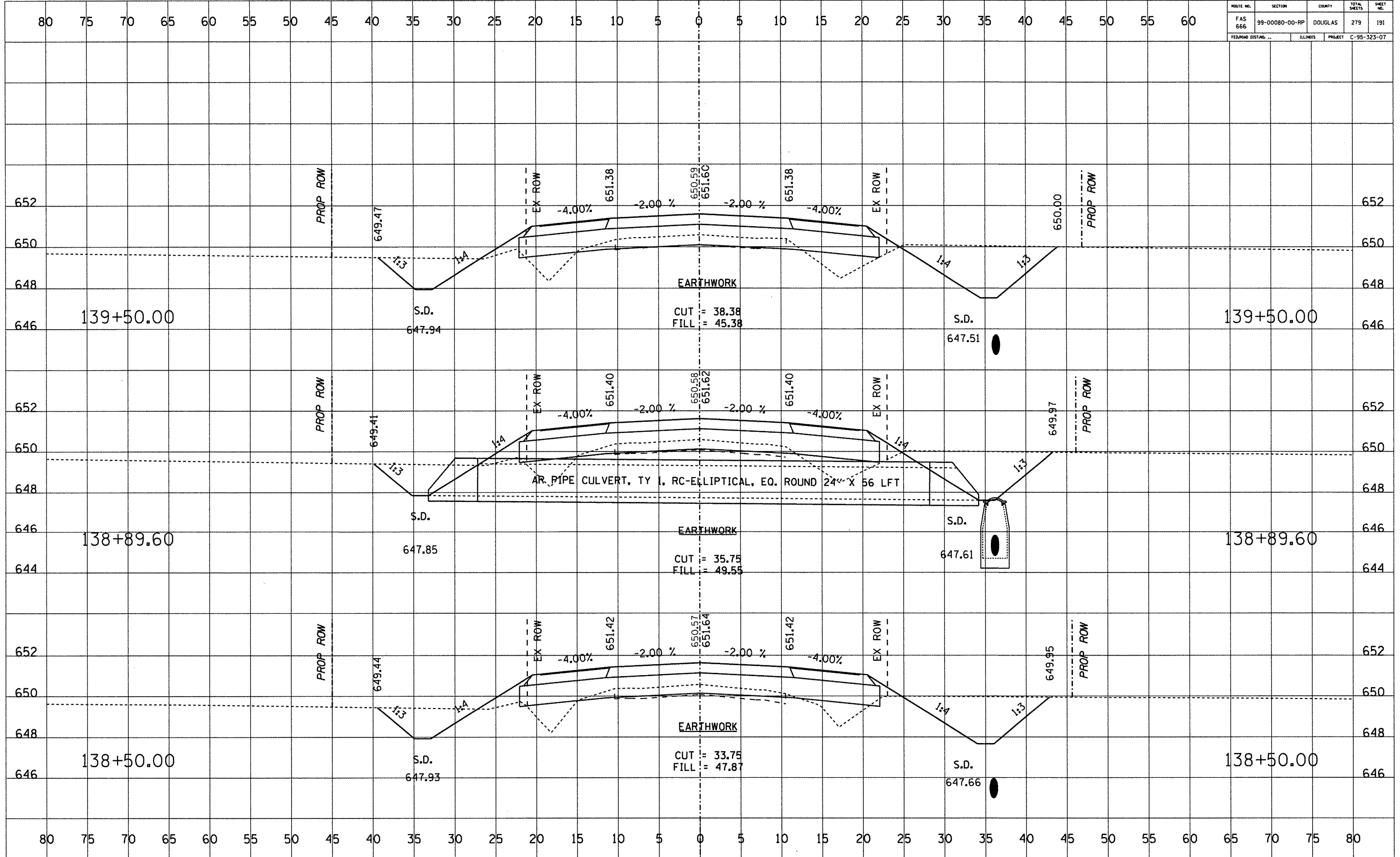

ROUTE NO.	SECTION	COUNTY	TOTAL SHEETS	SHEET NO.
FAS 666	99-00080-00-RP	DOUGLAS	279	192
FEDERAL DIST. NO. ...		ILLINOIS	PROJECT	C-95-323-07

DATE	BY

DATE	BY

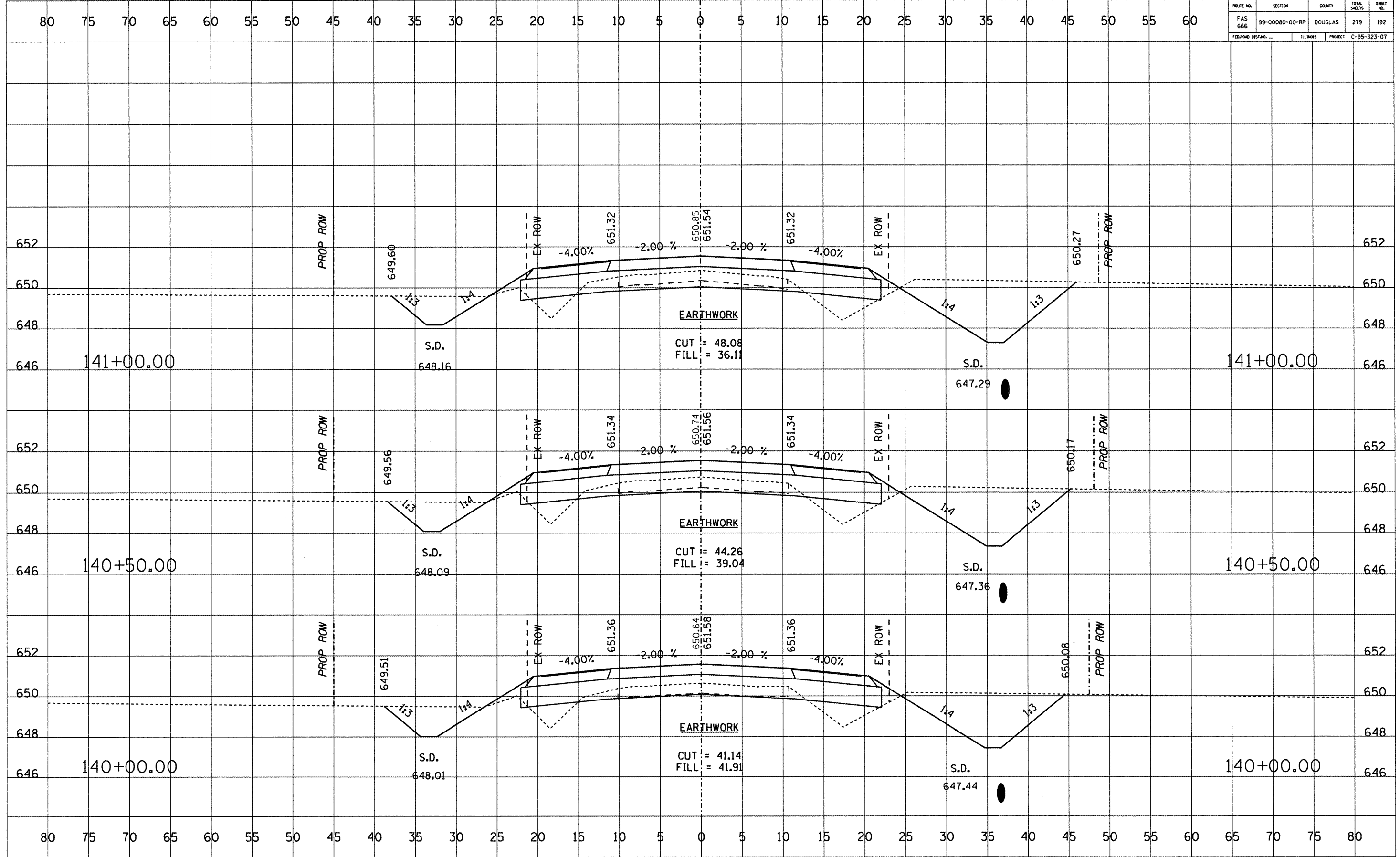

ROUTE NO.	SECTION	COUNTY	TOTAL SHEETS	SHEET NO.
FAS 666	99-00080-00-RP	DOUGLAS	279	193
FEDORAD DISTNO.	ILLINOIS	PROJECT	C-95-323-07	

DATE	BY
NO.	
NO.	
NO.	
NO.	

DATE	BY
NO.	
NO.	
NO.	
NO.	

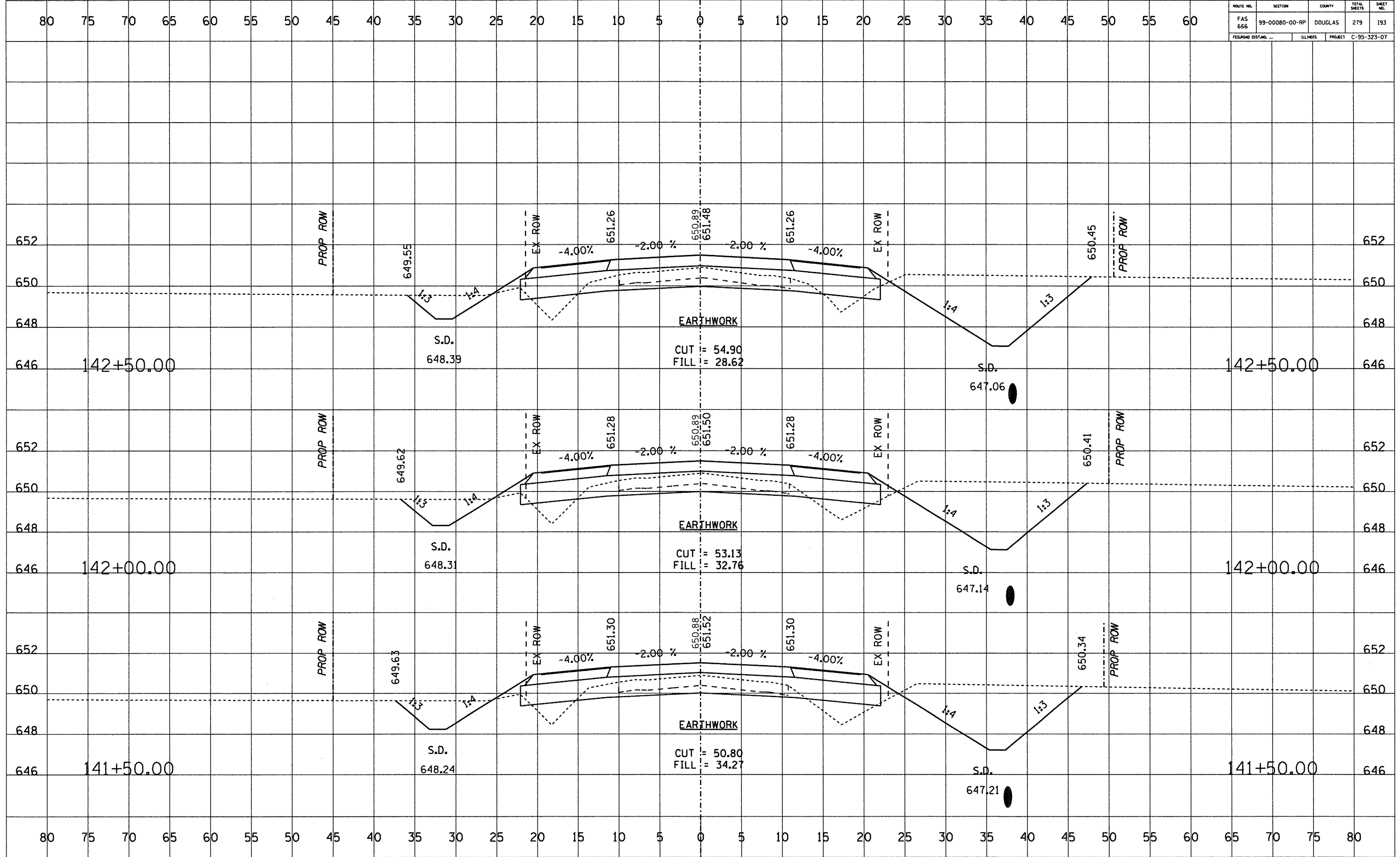

ROUTE NO.	SECTION	COUNTY	TOTAL SHEETS	SHEET NO.
FAS 666	99-00080-00-RP	DOUGLAS	279	194
FEDERAL DIST. NO.		ILLINOIS	PROJECT C-95-323-07	

DATE	BY

DATE	BY

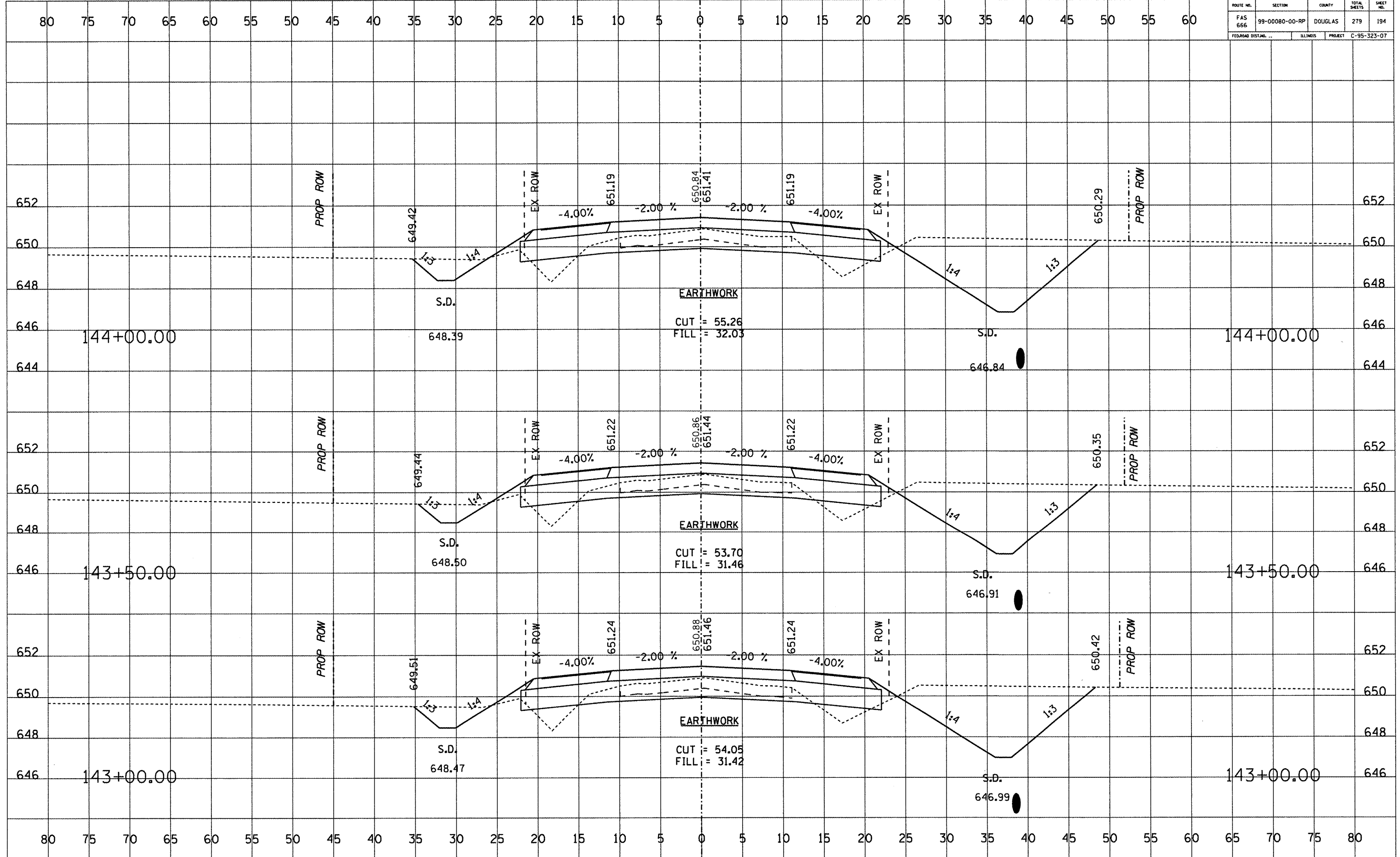

ROUTE NO.	SECTION	COUNTY	TOTAL SHEETS	SHEET NO.
FAS 666	99-00080-00-RP	DOUGLAS	279	195
FEDERAL DIST. NO.		ILLINOIS	PROJECT C-95-323-07	

DATE	
BY	
NO.	
FINAL SURVEY	
REVISIONS	
PLOTTED	
TEMPLATE	
NOTE BOOK	
AREAS CHECKED	

DATE	
BY	
NO.	
ORIGINAL SURVEY	
REVISIONS	
PLOTTED	
TEMPLATE	
NOTE BOOK	
AREAS CHECKED	

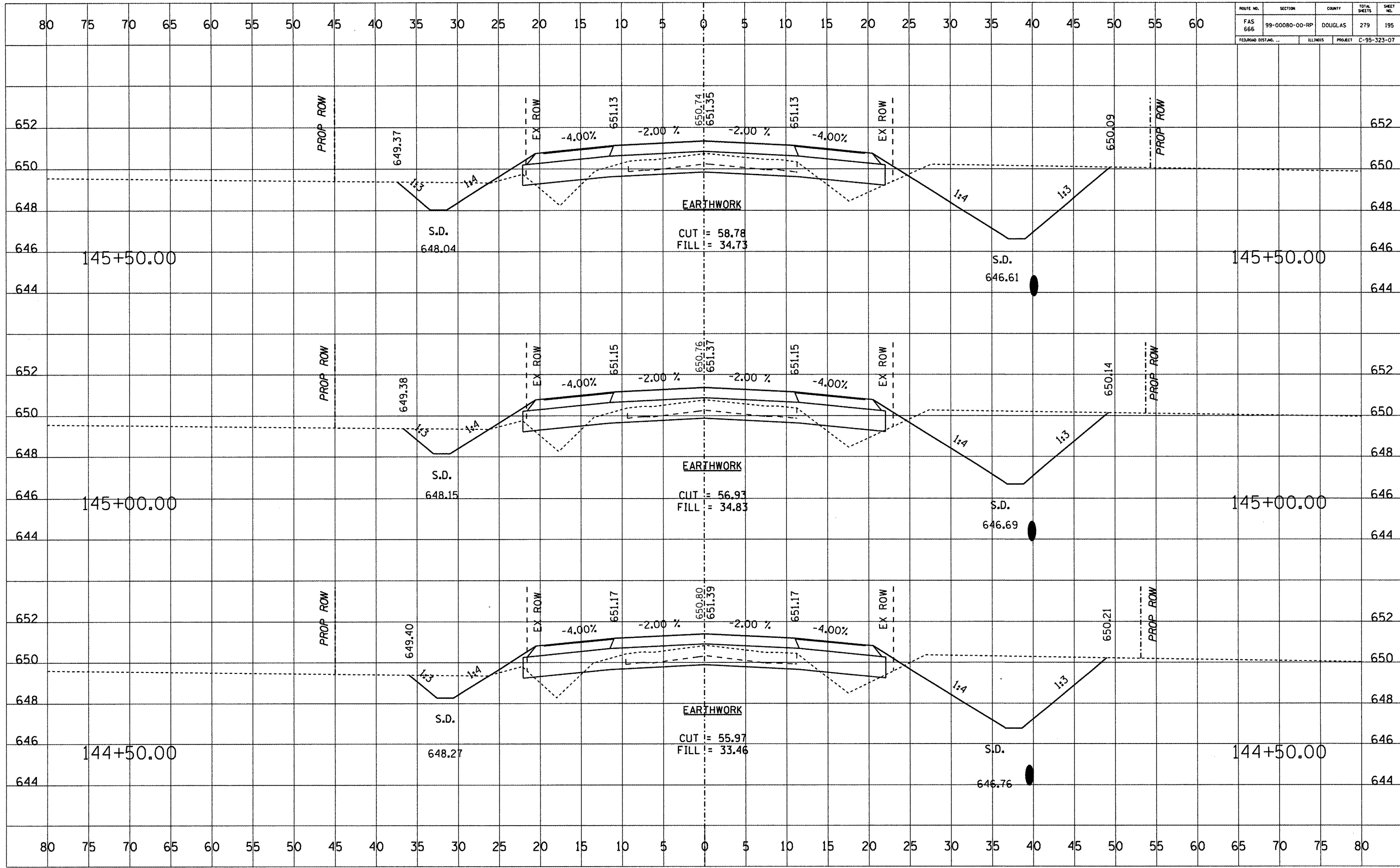

ROUTE NO.	SECTION	COUNTY	TOTAL SHEETS	SHEET NO.
FAS 666	99-00080-00-RP	DOUGLAS	279	196
FEDERAL DIST. NO.	ILLINOIS	PROJECT	C-95-323-07	

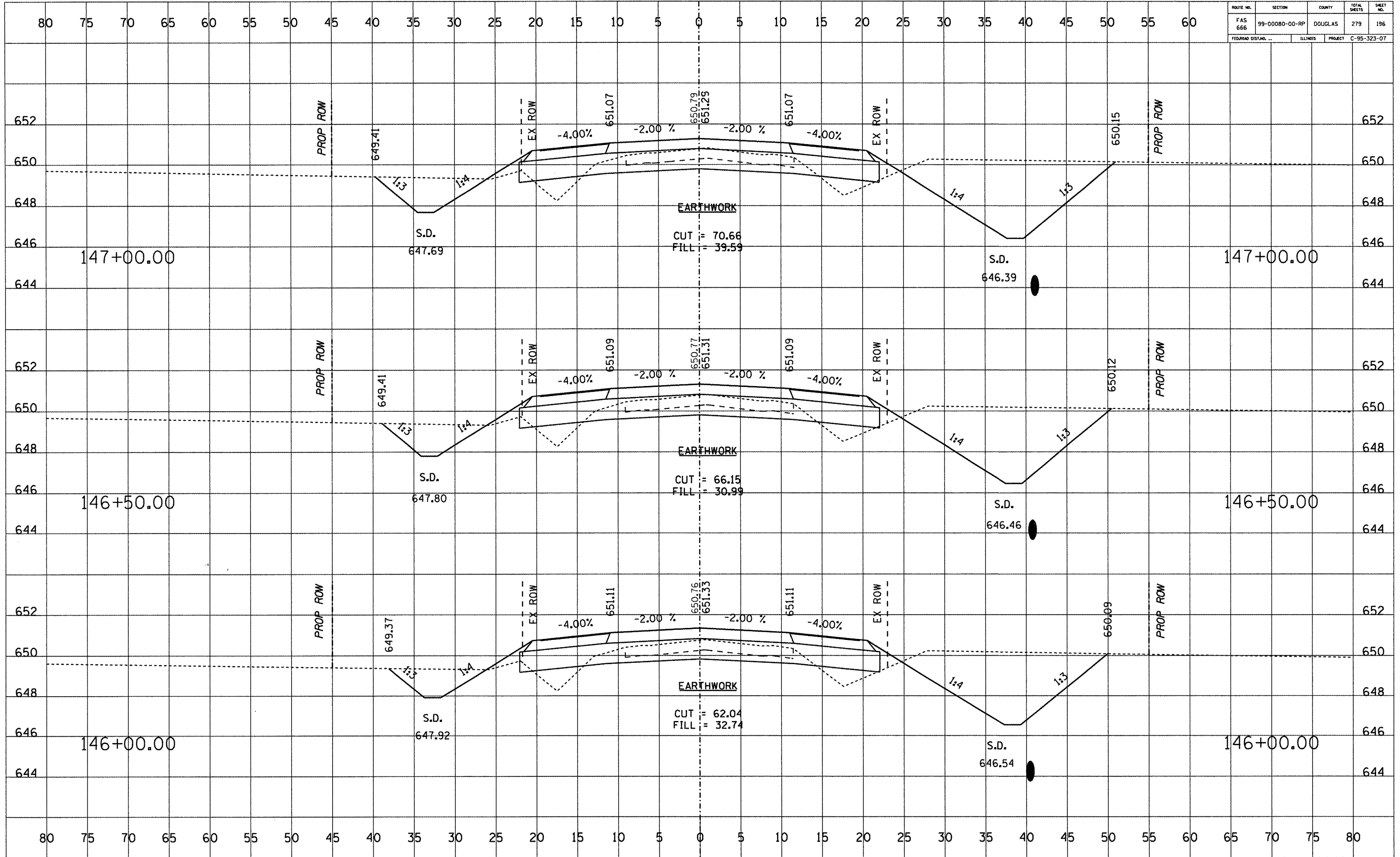

DATE	BY

DATE	BY



ROUTE NO.	SECTION	COUNTY	TOTAL SHEETS	SHEET NO.
FAS 666	99-00080-00-RP	DOUGLAS	279	197
FEDERAL DIST. NO.		ILLINOIS	PROJECT C-95-323-07	

DATE	BY
FINAL SURVEY	SURVEYED
NOTE BOOK NO.	PLOTTED
	REPLATE
	AREAS CHECKED

DATE	BY
ORIGINAL SURVEY	SURVEYED
NOTE BOOK NO.	PLOTTED
	REPLATE
	AREAS CHECKED

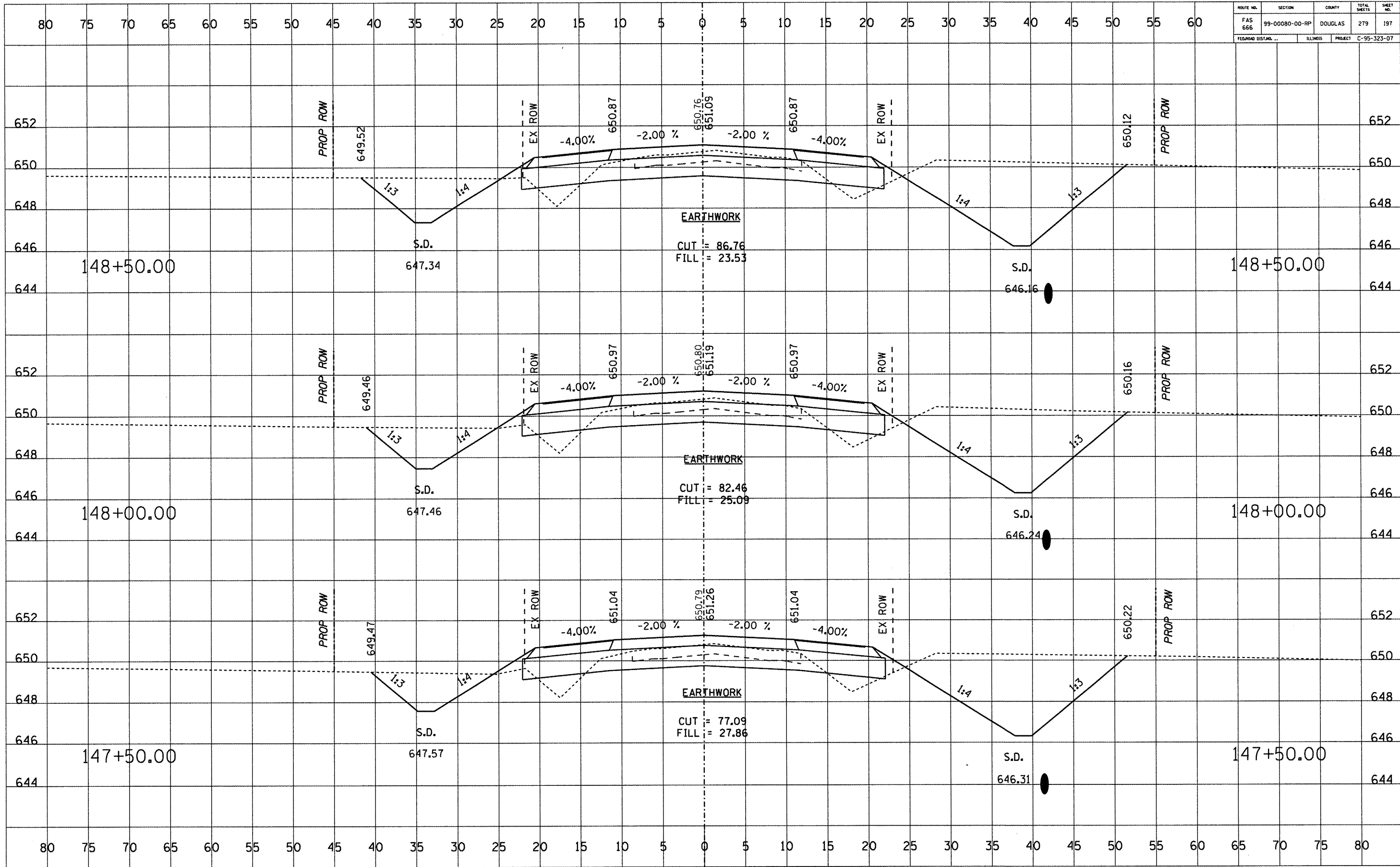

ROUTE NO.	SECTION	COUNTY	TOTAL SHEETS	SHEET NO.
FAS 666	99-00080-00-RP	DOUGLAS	279	198
FEDERAL DISTRICT	ILLINOIS	PROJECT	C-95-323-07	

DATE	BY

DATE	BY

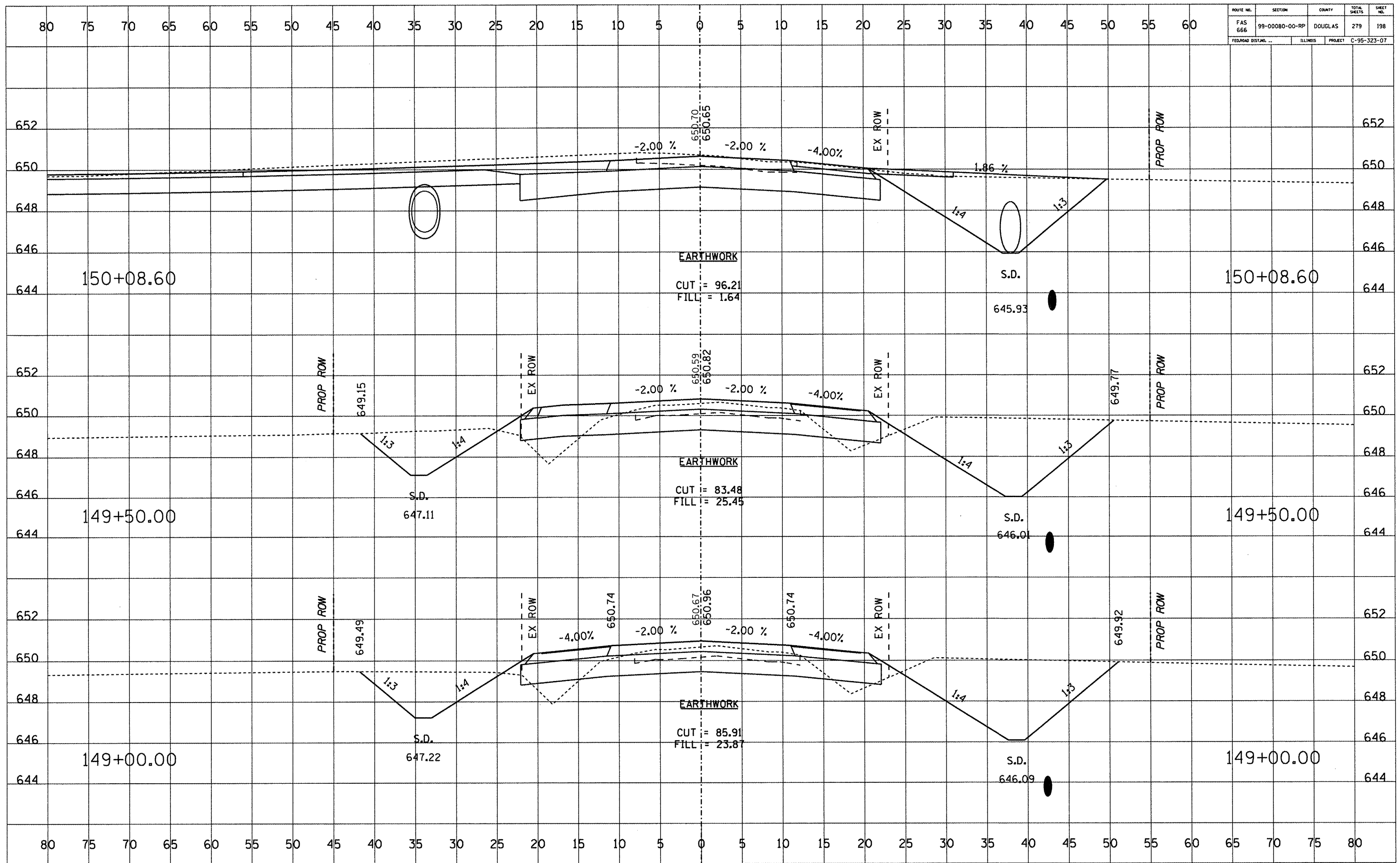

ROUTE NO.	SECTION	COUNTY	TOTAL SHEETS	SHEET NO.
FAS 666	99-00080-00-RP	DOUGLAS	279	199
FEDERAL DIST. NO. ...		ILLINOIS	PROJECT C-95-323-07	

DATE	
BY	
REVISIONS	
NO.	
DATE	
BY	
REVISIONS	
NO.	
DATE	
BY	
REVISIONS	
NO.	

DATE	
BY	
REVISIONS	
NO.	
DATE	
BY	
REVISIONS	
NO.	
DATE	
BY	
REVISIONS	
NO.	

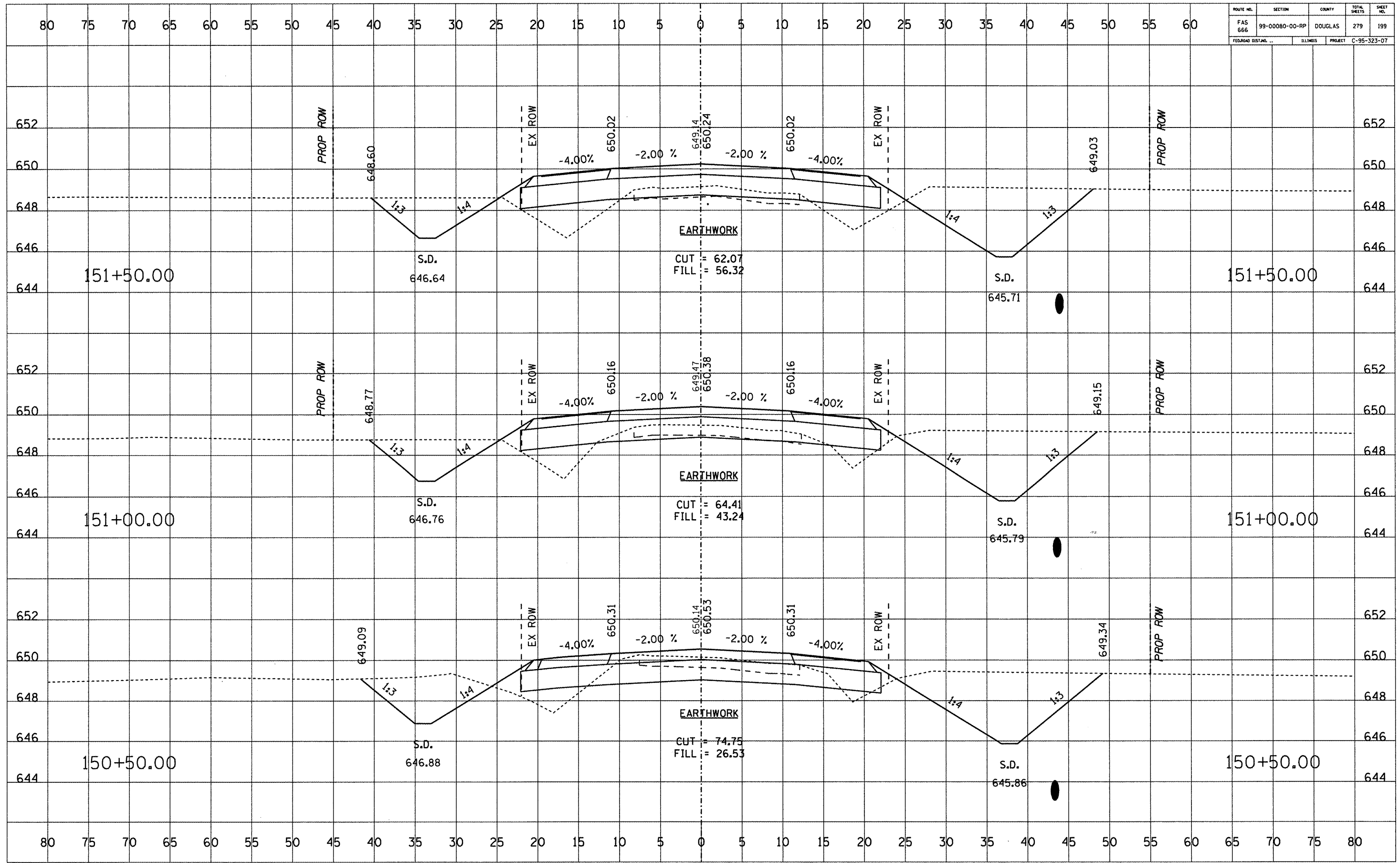

ROUTE NO.	SECTION	COUNTY	TOTAL SHEETS	SHEET NO.
FAS 666	99-00080-00-RP	DOUGLAS	279	200
FED. ROAD DIST. NO.	ILLINOIS	PROJECT	C-95-323-07	

DATE	BY

DATE	BY

