

F.A.U. ROUTE	SECTION	COUNTY	TOTAL SHEETS	SHEET NO.
8047	96-00379-00-PV	SANG	66	45
FED. ROAD DIST. NO.	ILLINOIS	FED. AID PROJECT		

STA. 491+90.00 TO STA. 492+00.00 10' OF THE EXISTING SURFACE 1 1/2" DEEP WILL BE REMOVED TO TRANSITION THE FINAL COURSE OF THE HOT-MIX ASPHALT PAVEMENT (FULL-DEPTH) OVER THE PROPOSED JOINT.

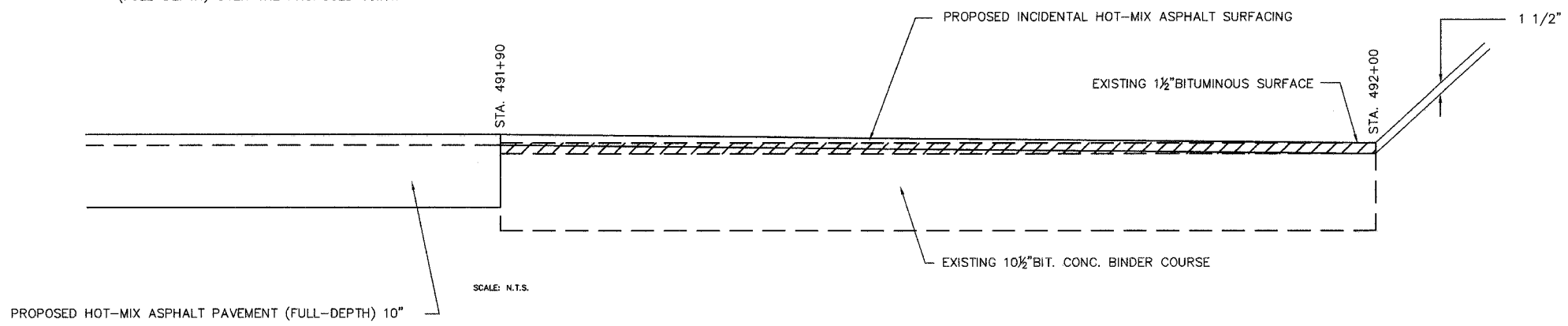

PROPOSED BUTT JOINT DETAIL

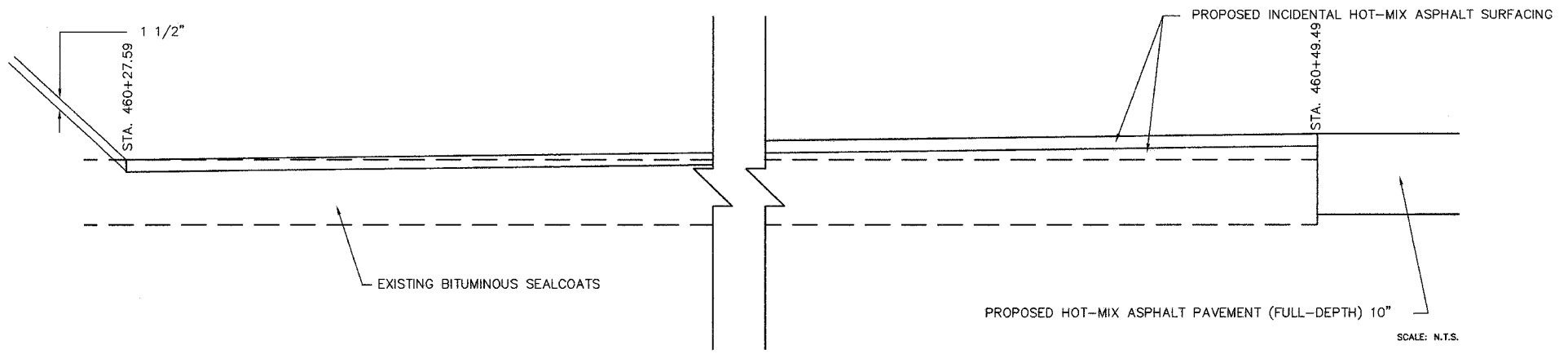

PROPOSED BUTT JOINT DETAIL

NO.	DATE	REVISION	BY
SHEET TITLE			PROJECT NO.
SPECIAL DETAILS			96100
PROJECT			SCALE
ILES AVENUE			1" = 20'
DRAWN BY			DATE
MEC			OCT. 2007
CHECKED BY			DRAWING FILE
PBW			C-DETL
DRAWING NO.			
 MARTIN ENGINEERING COMPANY of Illinois CONSULTING ENGINEERS/LAND SURVEYORS (ILLINOIS PROFESSIONAL DESIGN FIRM NO. 154-022943) 3223 S. MEADOWBROOK RD., SPRINGFIELD, ILLINOIS 62711 Phone: (217) 698-8900, Fax: (217) 698-8922, E-Mail: meconal@martinengineeringco.com			45
			OF 66 SHTS

Attached: 1/16/07 (Rev. 4) 1-17-07 (Rev. 1) 1-17-07 (Rev. 2) 1-17-07 (Rev. 3) 1-17-07 (Rev. 4) 1-17-07 (Rev. 5) 1-17-07 (Rev. 6) 1-17-07 (Rev. 7) 1-17-07 (Rev. 8) 1-17-07 (Rev. 9) 1-17-07 (Rev. 10) 1-17-07 (Rev. 11) 1-17-07 (Rev. 12) 1-17-07 (Rev. 13) 1-17-07 (Rev. 14) 1-17-07 (Rev. 15) 1-17-07 (Rev. 16) 1-17-07 (Rev. 17) 1-17-07 (Rev. 18) 1-17-07 (Rev. 19) 1-17-07 (Rev. 20) 1-17-07 (Rev. 21) 1-17-07 (Rev. 22) 1-17-07 (Rev. 23) 1-17-07 (Rev. 24) 1-17-07 (Rev. 25) 1-17-07 (Rev. 26) 1-17-07 (Rev. 27) 1-17-07 (Rev. 28) 1-17-07 (Rev. 29) 1-17-07 (Rev. 30) 1-17-07 (Rev. 31) 1-17-07 (Rev. 32) 1-17-07 (Rev. 33) 1-17-07 (Rev. 34) 1-17-07 (Rev. 35) 1-17-07 (Rev. 36) 1-17-07 (Rev. 37) 1-17-07 (Rev. 38) 1-17-07 (Rev. 39) 1-17-07 (Rev. 40) 1-17-07 (Rev. 41) 1-17-07 (Rev. 42) 1-17-07 (Rev. 43) 1-17-07 (Rev. 44) 1-17-07 (Rev. 45) 1-17-07 (Rev. 46) 1-17-07 (Rev. 47) 1-17-07 (Rev. 48) 1-17-07 (Rev. 49) 1-17-07 (Rev. 50) 1-17-07 (Rev. 51) 1-17-07 (Rev. 52) 1-17-07 (Rev. 53) 1-17-07 (Rev. 54) 1-17-07 (Rev. 55) 1-17-07 (Rev. 56) 1-17-07 (Rev. 57) 1-17-07 (Rev. 58) 1-17-07 (Rev. 59) 1-17-07 (Rev. 60) 1-17-07 (Rev. 61) 1-17-07 (Rev. 62) 1-17-07 (Rev. 63) 1-17-07 (Rev. 64) 1-17-07 (Rev. 65) 1-17-07 (Rev. 66) 1-17-07 (Rev. 67) 1-17-07 (Rev. 68) 1-17-07 (Rev. 69) 1-17-07 (Rev. 70) 1-17-07 (Rev. 71) 1-17-07 (Rev. 72) 1-17-07 (Rev. 73) 1-17-07 (Rev. 74) 1-17-07 (Rev. 75) 1-17-07 (Rev. 76) 1-17-07 (Rev. 77) 1-17-07 (Rev. 78) 1-17-07 (Rev. 79) 1-17-07 (Rev. 80) 1-17-07 (Rev. 81) 1-17-07 (Rev. 82) 1-17-07 (Rev. 83) 1-17-07 (Rev. 84) 1-17-07 (Rev. 85) 1-17-07 (Rev. 86) 1-17-07 (Rev. 87) 1-17-07 (Rev. 88) 1-17-07 (Rev. 89) 1-17-07 (Rev. 90) 1-17-07 (Rev. 91) 1-17-07 (Rev. 92) 1-17-07 (Rev. 93) 1-17-07 (Rev. 94) 1-17-07 (Rev. 95) 1-17-07 (Rev. 96) 1-17-07 (Rev. 97) 1-17-07 (Rev. 98) 1-17-07 (Rev. 99) 1-17-07 (Rev. 100)