

F.A.P. RTE.	SECTION	COUNTY	TOTAL SHEETS	SHEET NO.
781	1YRS, 2ZRS-1	CRAWFORD	378	135
STA.	TO STA.			
FED. ROAD DIST. NO.	ILLINOIS	FED. AID PROJECT		

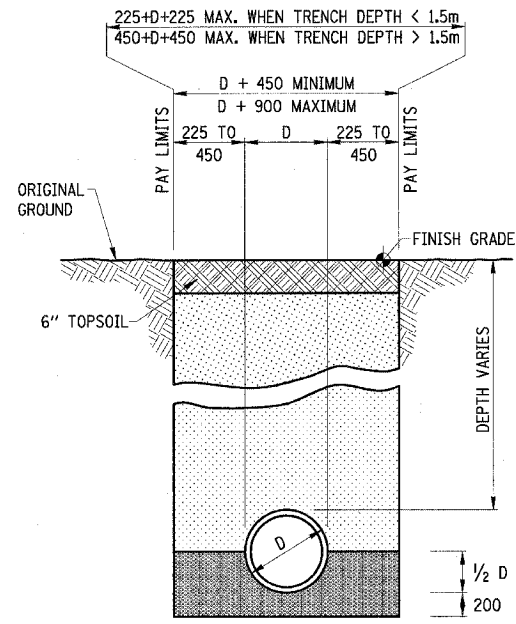

TRENCHING DETAIL UNDER UNPAVED AREAS

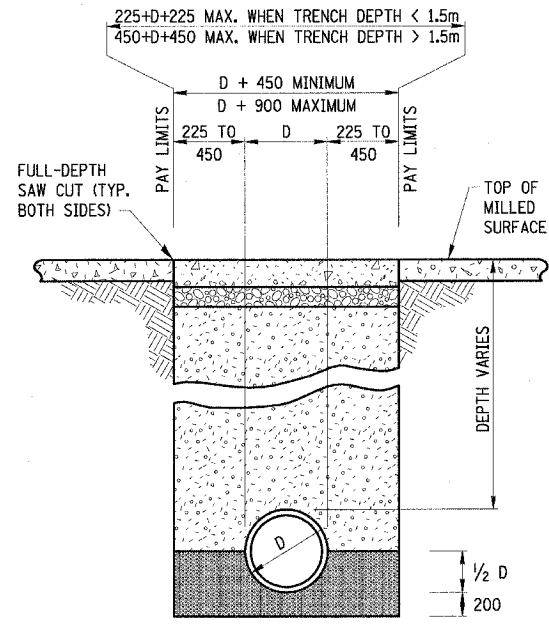

TRENCHING DETAIL UNDER EXIST. PAVEMENT SURFACES

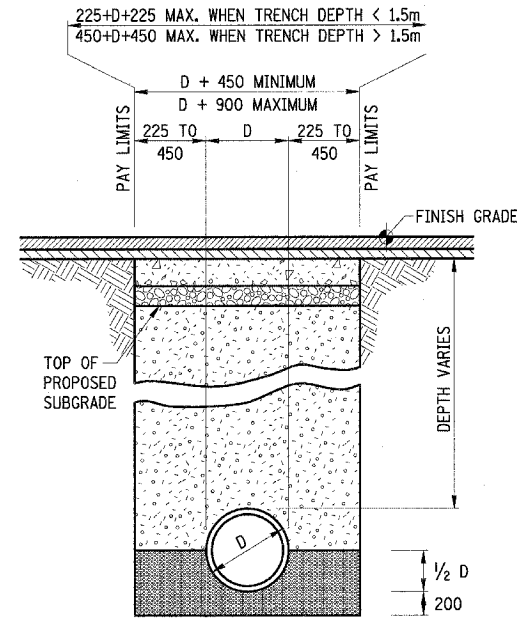

TRENCHING DETAIL UNDER NEW FULL-DEPTH PAVEMENT AREAS

LEGEND

- FINAL BACKFILL**
EXCAVATED MATERIAL IN OTHER LOCATIONS (INCLUDED IN COST OF PIPE)
- FINAL BACKFILL**
TRENCH BACKFILL PER 550.07 AND 208.01 OF THE STANDARD SPECIFICATIONS (PAY ITEM)
- BEDDING/CRADLE**
SELECT GRANULAR BACKFILL PER 550.04 AND 550.07 OF THE STANDARD SPECIFICATIONS (INCLUDED IN COST OF PIPE)

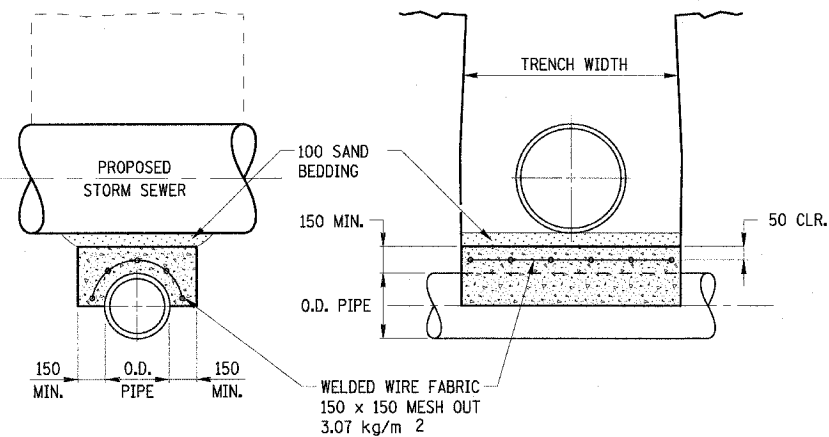

DETAIL - CONCRETE COVER FOR EXISTING UTILITIES

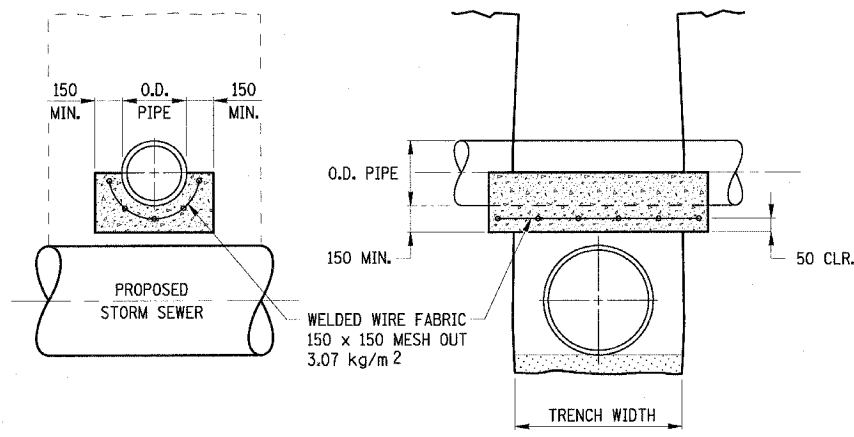

DETAIL - CONCRETE CRADLE FOR EXISTING UTILITIES

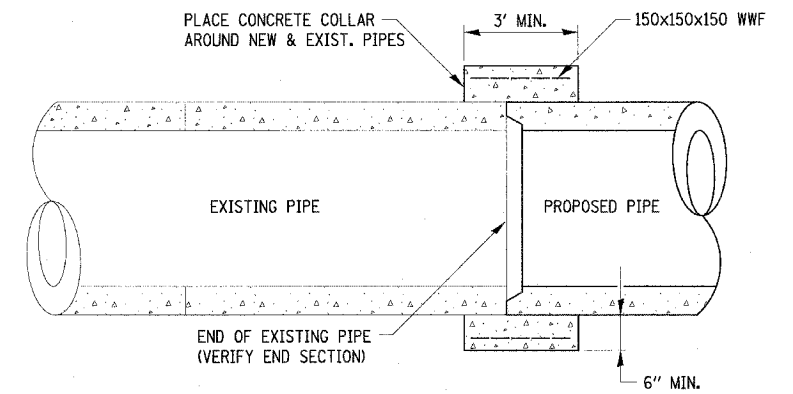

CONCRETE COLLAR DETAIL

NOTES

- CONCRETE CRADLES, COVERS AND COLLARS ARE TO BE PROVIDED AT LOCATIONS DESIGNATED BY THE ENGINEER WHERE THE PROPOSED STORM SEWER CROSSES EXISTING SANITARY SEWER, COMMUNICATION LINES, GAS LINES, AND/OR WATER LINES IN SUFFICIENT PROXIMITY THAT DEFLECTION OF THE EXISTING MAY OCCUR.
- THE COST OF THE CONCRETE CRADLES, COVERS AND COLLARS SHALL BE PAID FOR AT THE CONTRACT UNIT PRICE PER CUBIC METER FOR CLASS SI CONCRETE (SPECIAL).
- THE WELDED WIRE FABRIC AND SAND BEDDING MATERIAL WILL NOT BE PAID FOR SEPARATELY. THE COST FOR THESE ITEMS SHALL BE INCLUDED IN THE COST OF CLASS SI CONCRETE (SPECIAL).
- WOOD OR METAL FORMS WILL NOT BE REQUIRED.

ALL DIMENSIONS ARE IN MILLIMETERS UNLESS OTHERWISE SHOWN.

REVISIONS	
NAME	DATE

ILLINOIS DEPARTMENT OF TRANSPORTATION

STORM SEWER DETAILS

SCALE NO SCALE DRAWN BY EDW
DATE APRIL 18, 2008 CHECKED BY RGH

PLOT DATE = 4/18/2008
FILE NAME = H:\4428\78135.dwg

H. M. & G. NO. 4420