

F.A.U. ROUTE	SECTION	COUNTY	TOTAL SHEETS	SHEET NUMBER
9170	03-00054-00-RP	ST. CLAIR	41	29
STA. 2+22.78		TO	STA. 37+18.35	
FEDERAL AID PROJECT			CONTRACT 97335	

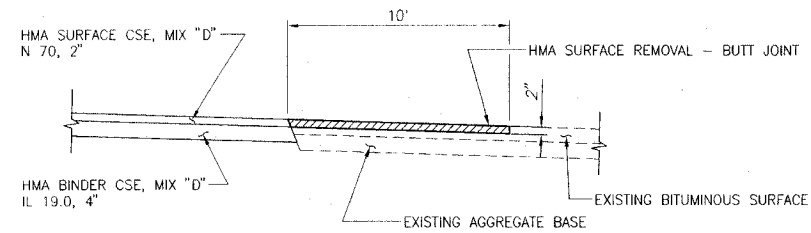

**MILLING DETAIL AT TERMINAL POINTS**

N.T.S.

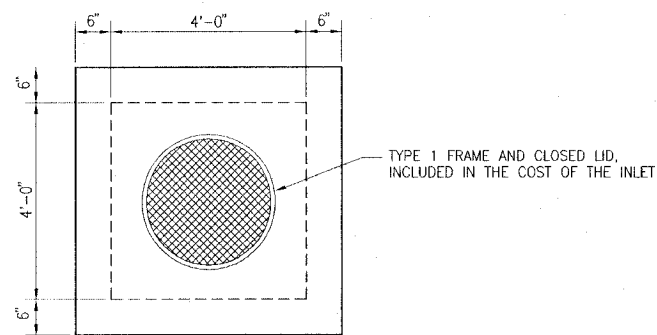

**PRECAST LID DETAIL**

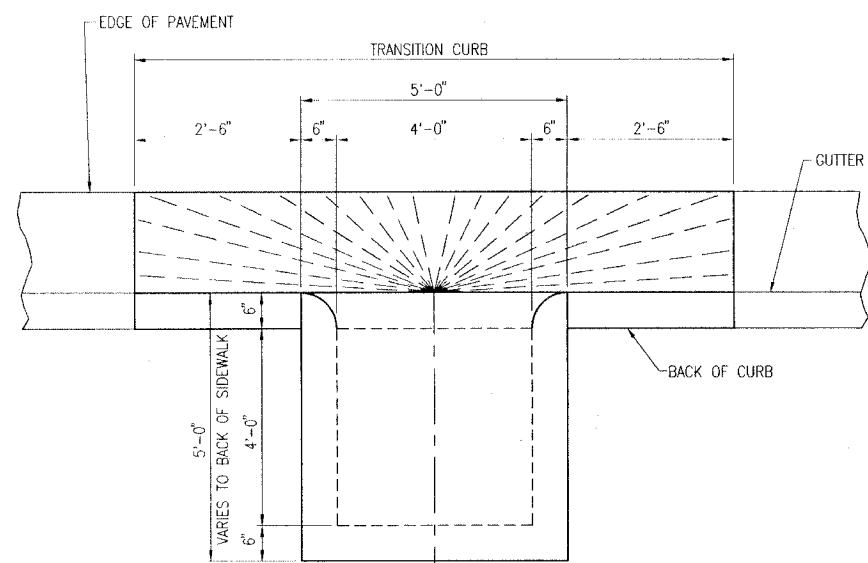

**PLAN**

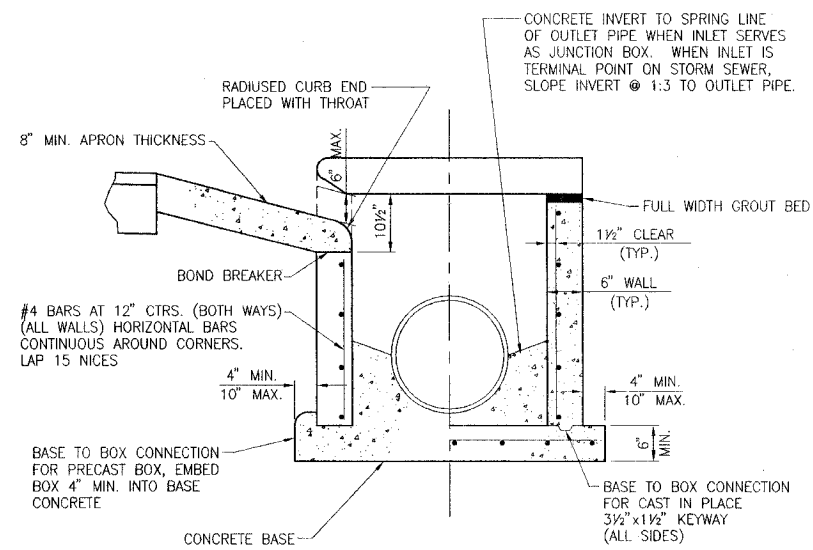

**PRECAST BASE      CAST IN PLACE**

**END VIEW**

**INLET, SPECIAL**

N.T.S.