

- NOTES:**
1. ALL DIMENSIONS ARE MINIMUM.
 2. INCLUDE DUCT SPACERS AS MANUFACTURED BY UNDERGROUND DEVICES INC., TO MAINTAIN PROPER SEPARATION OF CONDUITS.

CONCRETE ENCASED DUCT DETAIL
(2-WAY & 4-WAY SHOWN)

THE LOCATION OF UNDERGROUND UTILITIES AS INDICATED ON THE PLANS HAS BEEN OBTAINED FROM EXISTING RECORDS. NEITHER THE OWNER NOR THE ENGINEER ASSUMES ANY RESPONSIBILITY WHATSOEVER, IN RESPECT TO THE ACCURACY OR SUFFICIENCY OF THE INFORMATION AND THERE IS NO GUARANTEE, EITHER EXPRESSED OR IMPLIED, THAT THE CONDITIONS ARE REPRESENTATIVE OF THOSE TO BE ENCOUNTERED IN THE CONSTRUCTION.

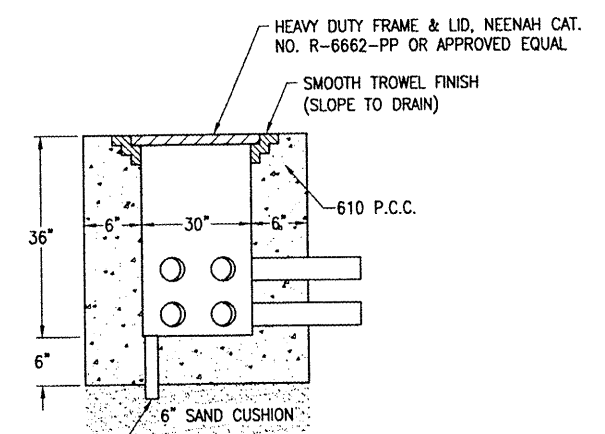

2" SCHED 40 PVC DRAIN PIPE. NOTE 6" OF CA-7 GRAVEL MAY BE PROVIDED, INSTEAD OF 6" CONCRETE FLOOR WITH DRAIN PIPE, AT CONTRACTORS OPTION.

- NOTE:**
1. LIDS FOR LOW VOLTAGE HANDHOLES SHALL BE LABELED "LOW VOLTAGE". LIDS FOR HIGH VOLTAGE HANDHOLES SHALL BE LABELED "HIGH VOLTAGE". COORDINATE LETTERING WITH MFR.
 2. HANDHOLE MAY BE CAST IN PLACE OR PRECAST.
 3. SEE SPECIAL PROVISIONS.

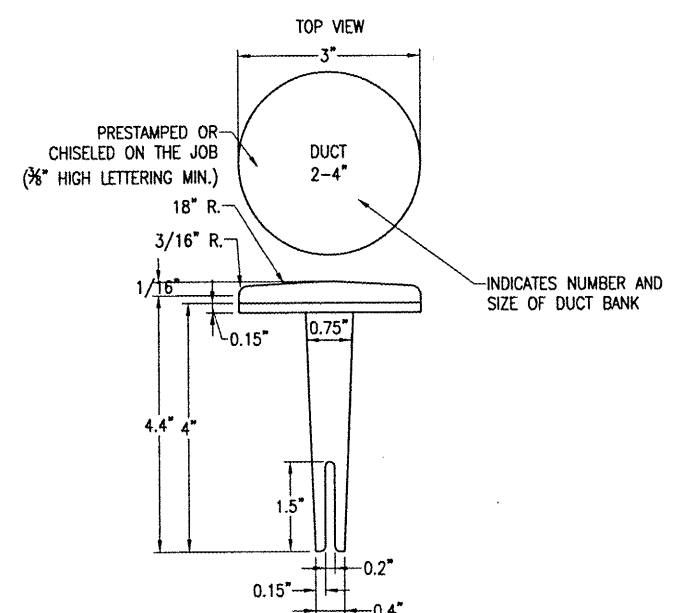

BITUMINOUS PAVEMENT DUCT MARKERS
"NOT TO SCALE"

NOTE: TOP OF MARKER SHALL BE FLUSH WITH FINISHED PAVEMENT SURFACE. MARKER MAY BE INSTALLED IN A DRILLED HOLE AND SECURED WITH EPOXY GLUE.

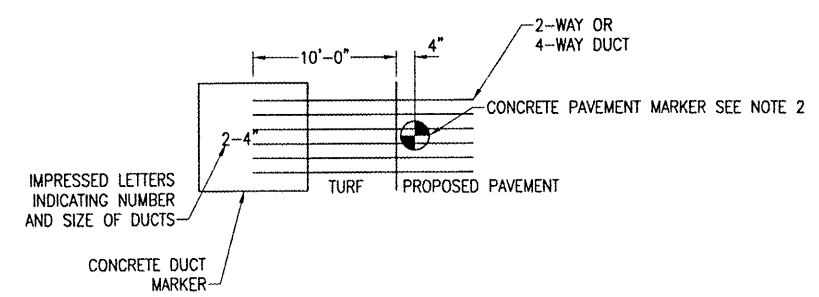

DUCT MARKER DETAIL
"NOT TO SCALE"

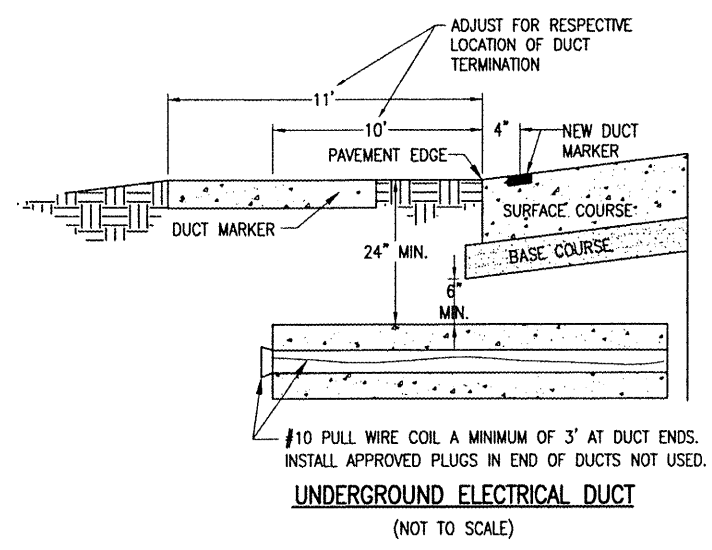

UNDERGROUND ELECTRICAL DUCT
"NOT TO SCALE"

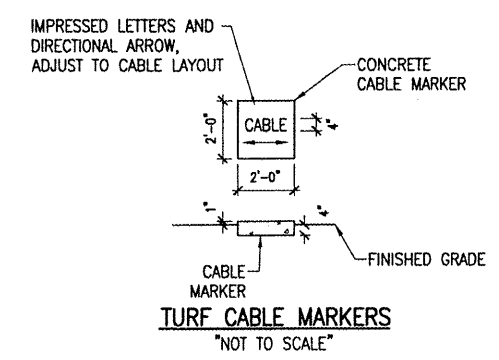

TURF CABLE MARKERS
"NOT TO SCALE"

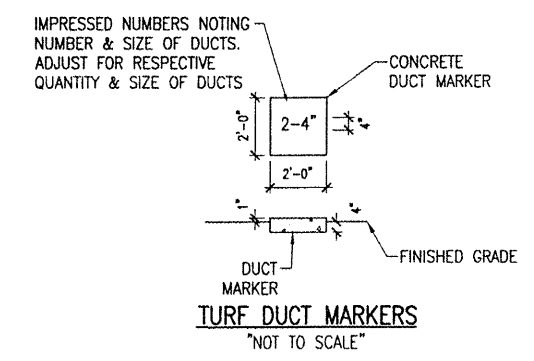

TURF DUCT MARKERS
"NOT TO SCALE"

- NOTES:**
1. THE COST OF ALL TURF AND PAVEMENT DUCT MARKERS SHALL BE INCIDENTAL TO THE DUCT. THE COST OF ALL CABLE MARKERS SHALL BE INCIDENTAL TO THE CABLE.
 2. BITUMINOUS PAVEMENT DUCT MARKER AND CONCRETE DUCT MARKER TO BE PROVIDED AT EACH END OF EACH DUCT AS SHOWN ON THE LOCATION PLAN. FOR CONCRETE PAVEMENT, THE LETTER "D" SHALL BE IMPRESSED IN THE PAVEMENT INSTEAD OF THE MARKER. THE LETTER SHALL BE IMPRESSED AS DESCRIBED IN NOTE 4.
 3. CABLE MARKERS SHALL BE PLACED AT CHANGES OF DIRECTION AND APPROXIMATELY EVERY 200' ALONG CABLE RUNS.
 4. CONCRETE CABLE MARKERS AND DUCT MARKERS SHALL HAVE LETTERS 4" HIGH, 3" WIDE WITH WIDTH OF STROKE 1/2" AND 1/4" DEEP. ALL LETTERS, NUMBERS AND ARROWS TO BE IMPRESSED.

BY	REVISION	DATE

LITCHFIELD MUNICIPAL AIRPORT
LITCHFIELD, ILLINOIS

IL. PROJ.: 31F-3559 A.I.P. PROJ.: 3-17-0063-B13

Project No. 814-06RWD-0800	DATE 01/17/08
Drawn R-543ELE.DWG	DATE 01/17/08
Scale N/A	DATE 01/29/08
DATE 01/29/08	DATE 01/29/08
LAYOUT MDR	REVIEWED CAH/KNL
DRAWN MDR	



PROPOSED P.F.C.
ON RUNWAY 9-27

ELECTRICAL DETAILS
SHEET 1