

# CONSTRUCTION PLANS FOR TRI-TOWNSHIP AIRPORT SAVANNA, CARROLL COUNTY, ILLINOIS REPLACE THE AIRFIELD ELECTRICAL VAULT

**SCOPE OF WORK**

THIS PROJECT CONSISTS OF THE CONSTRUCTION OF A NEW AIRPORT ELECTRICAL VAULT WITH NEW ELECTRICAL & MECHANICAL EQUIPMENT. THIS PROJECT INCLUDES NEW ELECTRICAL SERVICE, THE REMOVAL OF THE EXISTING ELECTRICAL VAULT AND ELECTRICAL EQUIPMENT, & INTERFACING/REPLACING CABLE TO EXISTING AIRFIELD LIGHTING SYSTEMS, AND IMPROVING THE GROUNDING OF THE AWOS.

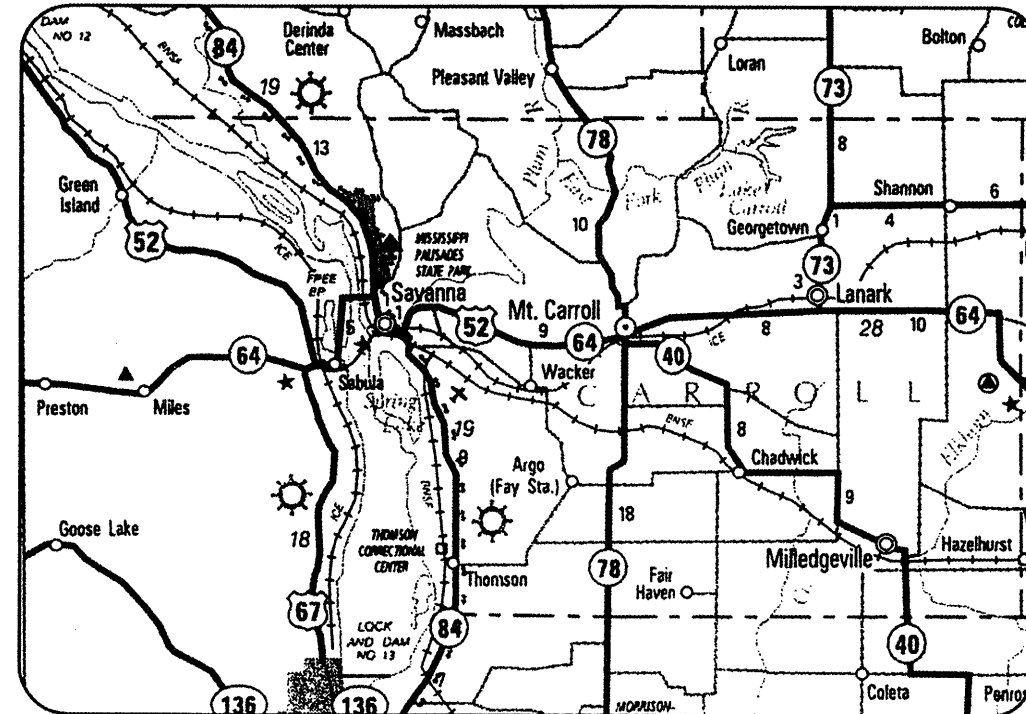

**LOCATION**

ILL. PROJ.: SFY-3782  
A.I.P. PROJ.: 3-17-0091-B14  
LATITUDE: 42° 02' 45"  
LONGITUDE: 90° 06' 28"  
ELEVATION: 616' M.S.L.  
DATE: FEB., 8 2008



REVISED 05/13/08

**HANSON**  
Hanson Professional Services Inc.

Submitted by: *Kevin N. Lightfoot* P.E.  
Date Submitted: 5/14/2008  
Lic. Exp. Date: 11/30/2009

**TRI-TOWNSHIP AIRPORT AUTHORITY**

Approved: *William J. Bogenbach* CHAIRMAN  
Date: March 18, 2008  
Approved: *Kenel & Smith* SECRETARY  
Date: 3/18/08

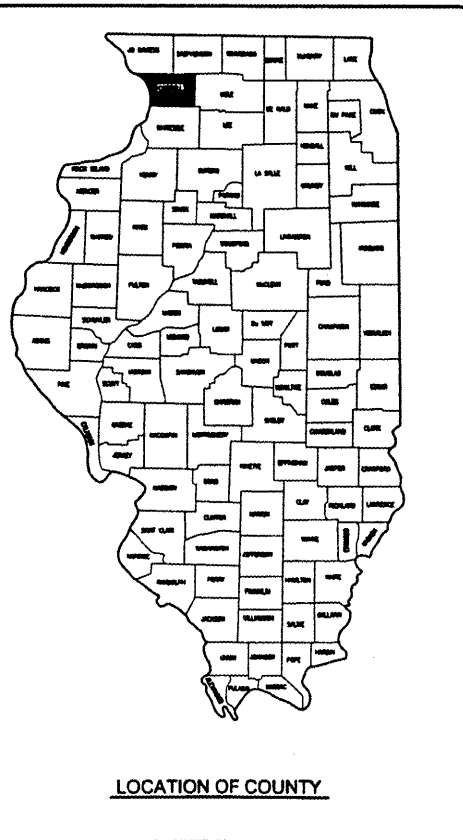

MAY 14, 2008 8:50 AM HINT001214  
I:\AIRPORTS\SAVANNA\07A0144\CAD\SHEETS\R-001CVR.DWG - COVER

DATE	REVISION						
TRI-TOWNSHIP AIRPORT SAVANNA, CARROLL COUNTY ILLINOIS							
IL. PROJ.: SFY-3782    A.I.P. PROJ.: 3-17-0091-B14							
HD Project No. 07A01440_0800 Filename: R-001CVR.DWG Scale: NOT TO SCALE Date: 05/13/08							
LAYOUT	BAK	12/3/07					
DRAWN	BAK	12/3/07					
REVIEWED	CAH/RNL	02/09/08					
Hanson Professional Services Inc. 1525 South Sixth Street Springfield, IL 62703-2686 Office: Hannibal							
CONSTRUCT NEW VAULT				COVER SHEET			
1 1 of 24 sheets							

TR005

SUMMARY OF QUANTITIES

ITEM NO.	DESCRIPTION	UNIT	TOTAL QUANTITIES	AS BUILT QUANTITIES
AR108158	1/C #8 5KV UG CABLE IN UD	LF	600	
AR108752	1/C #2 GROUND	LF	180	
AR109110	ERECT PRE-FABRICATED VAULT	LS	1	
AR109200	INSTALL ELECTRICAL EQUIPMENT	LS	1	
AR109901	REMOVE ELECTRICAL VAULT	LS	1	
AR110014	4" DIRECTIONAL BORE	LF	210	
AR110504	4-WAY CONCRETE ENCASED DUCT	LF	185	
AR110610	ELECTRICAL HANDHOLE	EA	3	
AR150510	ENGINEER'S FIELD OFFICE	LS	1	
AR800441	INSTALL 30-FOOT GROUND ROD	EA	2	
AR800442	INSTALL 40-FOOT GROUND ROD	EA	2	

INDEX TO SHEETS

SHEET NO.	DESCRIPTION
1	COVER SHEET
2	SUMMARY OF QUANTITIES AND INDEX TO SHEETS
3	PROPOSED SAFETY PLAN
4	ELECTRICAL LEGEND AND ABBREVIATIONS
5	EXISTING AIRPORT VAULT SITE PLAN
6	EXISTING VAULT ELECTRICAL ONE-LINE DIAGRAM
7	PROPOSED AIRPORT VAULT SITE PLAN
8	PROPOSED AIRPORT VAULT EQUIPMENT PLAN
9	PROPOSED VAULT LIGHTING AND RECEPTACLE PLAN
10	PROPOSED AIRPORT VAULT WALL ELEVATIONS
11	PROPOSED VAULT ELECTRICAL ONE-LINE DIAGRAM
12	PANEL SCHEDULES & DETAILS
13	HIGH VOLTAGE WIRING SCHEMATIC
14	AIRFIELD LIGHTING WIRING SCHEMATIC
15	RELAY/CONTACTOR PANEL DETAIL
16	LEGEND PLATE SCHEDULE
17	GROUNDING DETAILS
18	GROUNDING NOTES
19	ELECTRICAL DETAILS SHEET 1
20	ELECTRICAL DETAILS SHEET 2
21	ELECTRICAL DETAILS SHEET 3
22	ELECTRICAL NOTES SHEET 1
23	ELECTRICAL NOTES SHEET 2
24	AWOS GROUNDING IMPROVEMENTS

DATE	REVISION	BY

TRI-TOWNSHIP AIRPORT  
 SAVANNA, CARROLL COUNTY  
 ILLINOIS

PL Project No. 07A0144D_0800	FILENAME R-002FLP.DWG	DATE 05/13/08	SCALE NOT TO SCALE
LAYOUT	BAK	12/3/07	
DRAWN	BAK	12/3/07	
REVIEWED	CAH/KNL	02/08/08	

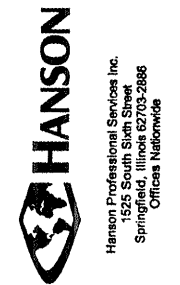

CONSTRUCT  
 NEW VAULT  
 SUMMARY OF QUANTITIES  
 AND  
 INDEX TO SHEETS

**SCOPE OF WORK**

THIS PROJECT CONSISTS OF THE CONSTRUCTION OF A NEW AIRPORT ELECTRICAL VAULT WITH NEW ELECTRICAL & MECHANICAL EQUIPMENT. THIS PROJECT INCLUDES NEW ELECTRICAL SERVICE, THE REMOVAL OF THE EXISTING ELECTRICAL VAULT AND ELECTRICAL EQUIPMENT, & INTERFACING/REPLACING CABLE TO EXISTING AIRFIELD LIGHTING SYSTEMS.

**AIRPORT SECURITY NOTE**

AIRPORT SECURITY WILL BE MAINTAINED AT ALL TIMES. THE CONTRACTOR WILL CLOSE AND LOCK THE EXISTING GATE IN THE HAUL ROUTE AT THE END OF EACH WORKING DAY.

**UTILITY NOTE**

THE CONTRACTOR SHALL CONTACT ALL UTILITY COMPANIES AND AGENCIES WHICH HAVE LINES OR CONDUITS IN THE PROPOSED WORK AREA. ALL LINES AND CONDUITS SHALL BE LOCATED AND IDENTIFIED FOR DEPTH BEFORE ANY EXCAVATION BEGINS. THE CONTRACTOR WILL CALL J.U.L.I.E. (1-800-892-0123) TO ACCOMPLISH THE ABOVE. IT IS THE CONTRACTOR'S RESPONSIBILITY TO IDENTIFY ALL UNDERGROUND NON-JULIE UTILITIES LOCATED WITHIN THE PROPOSED CONSTRUCTION LIMITS. THESE UNDERGROUND IMPROVEMENTS WILL BE LOCATED AT THE CONTRACTOR'S OWN EXPENSE PRIOR TO THE START OF CONSTRUCTION ACTIVITIES.

**HEIGHT OF CONSTRUCTION EQUIPMENT**

THE MAXIMUM ANTICIPATED HEIGHT OF THE CONSTRUCTION EQUIPMENT WILL BE 35 FEET. THE TALLEST EQUIPMENT IS EXPECTED TO BE A CRANE FOR PLACING THE VAULT BUILDING.

**HAUL ROUTE AND VEHICLE PARKING**

THE CONTRACTOR WILL USE THE DESIGNATED PARKING AREA AS SHOWN ON THIS SHEET. THE PROPOSED PARKING AREA WILL BE 200' X 200'. THE CONTRACTOR WILL BE REQUIRED TO MAINTAIN THE PROPOSED PARKING AREA THROUGHOUT THE COURSE OF THE PROJECT. ANY AREAS DAMAGED OUTSIDE OF THIS AREA WILL BE REPAIRED BY THE CONTRACTOR AND AT THE CONTRACTOR'S OWN EXPENSE. AT THE CONCLUSION OF THE PROJECT THE CONTRACTOR WILL GRADE, FERTILIZE, SEED AND MULCH THE PARKING AREA AS NEEDED TO RESTORE IT TO ITS ORIGINAL STATE. RESTORATION OF THE PARKING AREA WILL BE CONSIDERED INCIDENTAL TO THE PROJECT AND NO ADDITIONAL COMPENSATION WILL BE ALLOWED.

THE CONTRACTOR WILL BE ALLOWED TO USE THE EXISTING AIRPORT ENTRANCE ROAD AS HIS PROPOSED HAUL ROUTE. THE CONTRACTOR AND THE RESIDENT ENGINEER WILL WALK THE ENTRANCE ROAD PRIOR TO STARTING THE CONSTRUCTION AND WILL NOTE ANY PAVEMENT AREAS THAT ARE QUESTIONABLE. THE CONTRACTOR WILL BE REQUIRED TO MAINTAIN THE ENTRANCE ROAD THROUGHOUT THE DURATION OF THE PROJECT. AT THE CONCLUSION OF THE PROJECT, THE CONTRACTOR WILL RESTORE THE ENTRANCE ROAD TO ITS ORIGINAL STATE AT HIS OWN EXPENSE.

**CONTRACTOR RESPONSIBILITIES**

THE CONTRACTOR'S EQUIPMENT PARKING AND STORAGE AREA WILL BE AS SHOWN ON THIS SHEET. THE CONTRACTOR'S EMPLOYEES WILL PARK THEIR VEHICLES IN THIS AREA. ONLY CONTRACTOR VEHICLES WILL BE ALLOWED OUTSIDE THIS AREA.

THE CONTRACTOR AND HIS EMPLOYEES WILL BE RESTRICTED TO THE WORK AREA AND ALL OTHER AREAS OF THE AIRPORT ARE "OFF LIMITS" TO THEM.

THE CONTRACTOR SHALL KEEP RUNWAY 13-31 OPEN AT ALL TIMES AND MAINTAIN CONTINUOUS TAXIWAY ACCESS TO ALL HANGARS AND ADMINISTRATIVE AREAS.

ALL WORK PERFORMED SHALL BE DONE IN A ORDERLY AND EFFECTIVE MANNER TO MINIMIZE RUNWAY CLOSURE.





NO TRENCHES OR HOLES WILL REMAIN OPEN OVERNIGHT.

NO RUNWAY SHALL BE CLOSED OVERNIGHT.

**BARRICADES AND TRAFFIC CONES**

IT WILL BE THE CONTRACTOR'S RESPONSIBILITY TO PLACE AND MAINTAIN BARRICADES AND TRAFFIC CONES AS DIRECTED BY THE AIRPORT MANAGER. THE BARRICADES WILL BE EQUIPPED WITH RED FLASHING OR RED STEADY-BURN LIGHTS AND 20" SQUARE ORANGE FLAGS. THE BARRICADES, THEIR MAINTENANCE, PLACEMENT AND REMOVAL WILL BE CONSIDERED AS AN INCIDENTAL ITEM TO THE CONTRACT AND NO ADDITIONAL COMPENSATION WILL BE ALLOWED.

**LEGEND**

-  EXISTING IMPROVEMENTS
-  PROPOSED IMPROVEMENTS
-  EXISTING BUILDINGS
-  PROPOSED HAUL ROUTE AND EQUIPMENT PARKING AREA
-  PROPOSED BARRICADES OR TRAFFIC CONES

THE LOCATION, SIZE AND TYPE OF MATERIAL OF EXISTING UNDERGROUND UTILITIES INDICATED ON THE PLANS IS NOT REPRESENTED AS BEING ACCURATE, SUFFICIENT OR COMPLETE. IT SHALL BE THE CONTRACTOR'S RESPONSIBILITY TO DETERMINE THE ACTUAL LOCATION OF ALL SUCH FACILITIES, INCLUDING SERVICE CONNECTIONS TO UNDERGROUND UTILITIES. PRIOR TO CONSTRUCTION, THE CONTRACTOR SHALL NOTIFY THE UTILITY COMPANIES OF HIS OPERATIONAL PLANS AND SHALL OBTAIN FROM THE RESPECTIVE UTILITY COMPANIES DETAILED INFORMATION AND ASSISTANCE RELATIVE TO THE LOCATION OF THEIR FACILITIES AND THE WORKING SCHEDULE OF THE COMPANIES FOR REMOVAL OR ADJUSTMENT WHERE REQUIRED. IN THE EVENT AN UNEXPECTED UTILITY INTERFERENCE IS ENCOUNTERED DURING CONSTRUCTION, THE CONTRACTOR SHALL IMMEDIATELY NOTIFY THE UTILITY COMPANY OF JURISDICTION. THE ENGINEER SHALL ALSO BE IMMEDIATELY NOTIFIED. ANY SUCH MAINS AND SERVICES SHALL BE RESTORED TO SERVICE AT ONCE AND PAID FOR BY THE CONTRACTOR AT NO ADDITIONAL COST TO THE CONTRACT.

CALL J.U.L.I.E. FOR UTILITY INFORMATION AT 1-800-892-0123.

**CERTIFIED PAYROLLS**

THE RESIDENT ENGINEER WILL NOT FORWARD CONSTRUCTION REPORTS TO THE ILLINOIS DIVISION OF AERONAUTICS FOR PROCESSING UNTIL ALL CERTIFIED PAYROLLS FOR THE PERIOD HAVE BEEN RECEIVED.

**MATERIAL CERTIFICATION**

COMPLETED WORK CANNOT BE PLACED ON A CONSTRUCTION REPORT UNTIL ALL MATERIAL CERTIFICATIONS FOR THAT PAY ITEM HAVE BEEN RECEIVED, REVIEWED AND ACCEPTED BY THE RESIDENT ENGINEER.

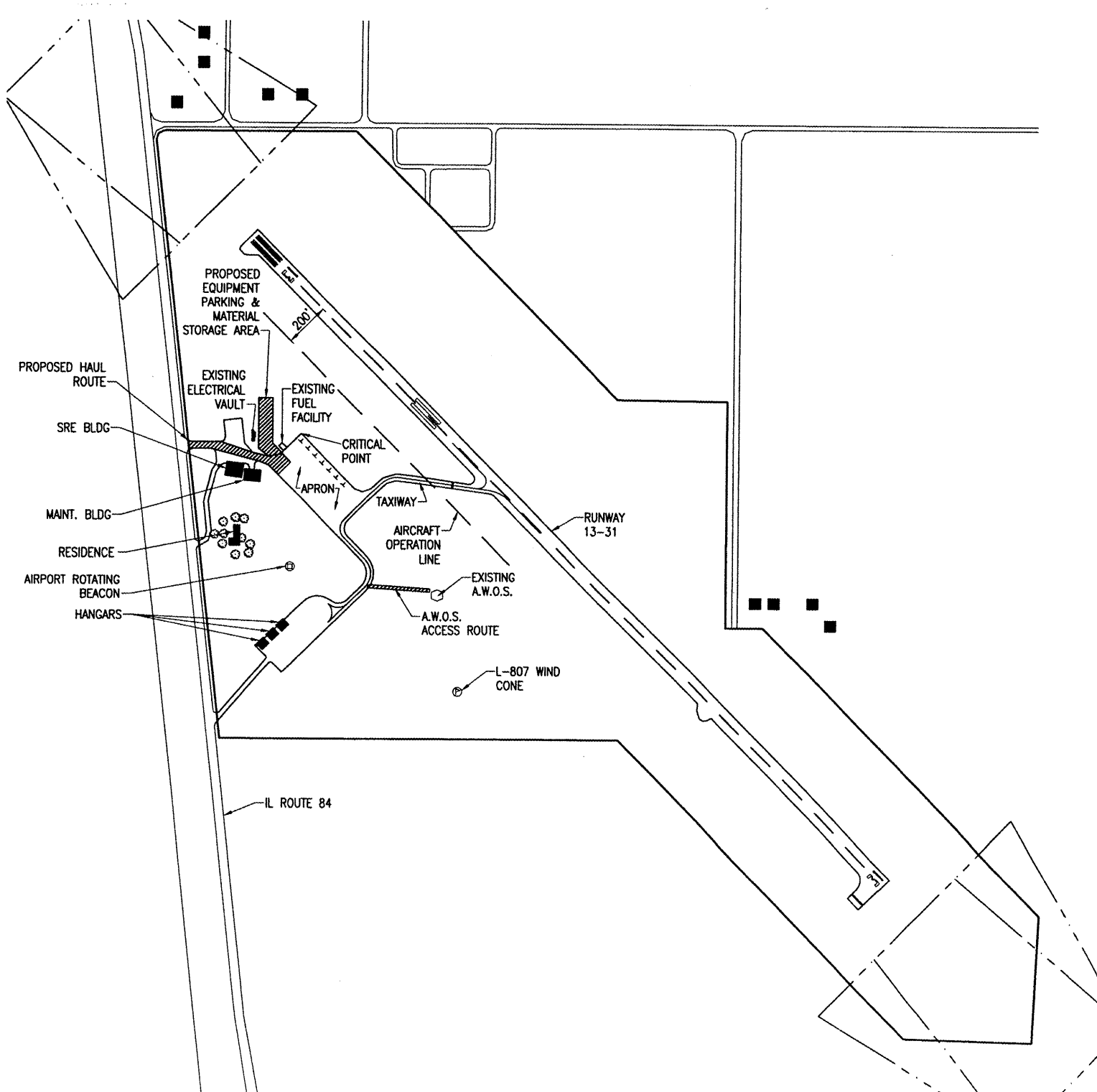

**J.U.L.I.E. INFORMATION**

COUNTY: CARROLL  
 CITY: SAVANNA  
 TOWNSHIP: SAVANNA  
 SECTION NO.: 25  
 ADDRESS: TRI-TOWNSHIP AIRPORT  
 8049 IL. ROUTE 84S  
 SAVANNA, ILLINOIS 61074

**CRITICAL POINT DATA**

LATITUDE: 42° 02' 50.57"  
 LONGITUDE: 90° 06' 44.15"  
 ELEVATION: 609.0' M.S.L.  
 TAXIWAY LIGHT OF NORTH EAST CORNER OF THE APRON

**PROPOSED SAFETY PLAN**

GENERAL - THE TRI-TOWNSHIP AIRPORT IS COMPRISED OF ONE RUNWAY. THE PROPOSED CONSTRUCTION WILL NOT NECESSITATE CLOSING THE RUNWAY.

IDENTIFICATION - WHEN THE CONTRACTORS VEHICLES AND EQUIPMENT ARE ON THE AIRPORT THEY SHALL BE PROPERLY MARKED WITH THREE (3') FOOT SQUARE CHECKERED FLAGS (INTERNATIONAL ORANGE AND WHITE). THE CONTRACTOR WILL ALSO PROVIDE WORKERS WITH SOME TYPE OF TAG OR GARMENT TO IDENTIFY THE PERSON AS BEING PART OF THE CONSTRUCTION CREW.

RADIO CONTROL - THE CONTRACTOR WILL BE REQUIRED TO BE IN TWO-WAY RADIO CONTACT (122.70 MHz.) WITH THE AIRPORT UNICOM. THIS WILL KEEP THE CONTRACTOR IN CONSTANT CONTACT WITH THE TRI-TOWNSHIP AIRPORT AND ENABLE THE AIRPORT TO IMMEDIATELY CONTACT THE CONTRACTOR IN CASE OF AN AERONAUTIC EMERGENCY THAT WOULD REQUIRE ACTION BY THE CONTRACTOR AND/OR HIS PERSONNEL.

**150-ENGINEER'S FIELD OFFICE NOTES**

THE PROPOSED ENGINEER'S FIELD OFFICE WILL BE FURNISHED, MAINTAINED, AND REMOVED IN ACCORDANCE WITH ITEM AR150510 "ENGINEER'S FIELD OFFICE" AS STATED ON PAGE 168 OF THE SUPPLEMENTAL SPECIFICATIONS AND RECURRING SPECIAL PROVISIONS, ADOPTED JANUARY 1, 2004.

THE CONTRACTOR WILL FURNISH A CELL PHONE TO THE RESIDENT ENGINEER FOR HIS EXCLUSIVE USE FOR THE DURATION OF THIS PROJECT. THE RESIDENT ENGINEER WILL USE THIS PHONE FOR PROJECT BUSINESS ONLY. THE CONTRACTOR WILL BE RESPONSIBLE FOR ALL CHARGES ASSOCIATED WITH THIS CELL PHONE.

THE PROPOSED CELL PHONE WILL BE PAID FOR UNDER ITEMS:

AR150510 ENGINEER'S FIELD OFFICE \_\_\_\_ 1 L.S.

**EROSION CONTROL**

THIS PROJECT WILL DISTURB LESS THAN 1 ACRE OF LAND, THEREFORE NO N.P.D.E.S. PERMIT WILL BE REQUIRED.

**AIRCRAFT OPERATION LINE**

THE CONTRACTOR WILL LOCATE THIS LINE AT THE START OF CONSTRUCTION AND WILL PLACE FLAGGED LATHE EVERY 150' ALONG IT. THIS LINE WILL BE THE LIMITS THAT ALL CONTRACTOR PERSONNEL MAY VENTURE WHEN A RUNWAY IS NOT CLOSED. THE CONTRACTOR WILL MAINTAIN THE LATHE LINE FOR RUNWAYS.

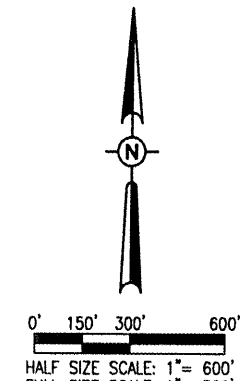

	<b>TR005</b>				
COUNTY: CARROLL CITY: SAVANNA TOWNSHIP: SAVANNA SECTION NO.: 25 ADDRESS: TRI-TOWNSHIP AIRPORT 8049 IL. ROUTE 84S SAVANNA, ILLINOIS 61074		LATITUDE: 42° 02' 50.57" LONGITUDE: 90° 06' 44.15" ELEVATION: 609.0' M.S.L. TAXIWAY LIGHT OF NORTH EAST CORNER OF THE APRON		BY: CAH REVISION: PER JDA REVIEW DATE: 5/13/08	
<b>TRI-TOWNSHIP AIRPORT                  SAVANNA, CARROLL COUNTY                  ILLINOIS</b>					
HEL Project No.: 07A01440_0800 Estimate: R-0035FY.DWG State: ILL. Date: 02/08/08		LAYOUT: 12/3/07 DRAWN: BAK REVIEWED: CAH		A.I.P. PROJ.: 3-17-0091-B14 I.L. PROJ.: SFY-3782	
 Hanson Professional Services Inc. 1525 South Sixth Street Springfield, Illinois 62703-2888 Offices Nationwide					
<b>CONSTRUCT                  NEW VAULT</b>		<b>PROPOSED                  SAFETY                  PLAN</b>			
3					
3 of 24 sheets					

MAY 13, 2008 2:46 PM HAGL000382  
 I:\AIRPORTS\SAVANNA\07A0144\CAD\SHEETS\R-0035FY.DWG - Layout1

ELECTRICAL LEGEND - ONE-LINE DIAGRAM	
	CABLE TERMINATOR/LUG
	TRANSFORMER
	DISCONNECT SWITCH
	FUSIBLE DISCONNECT SWITCH
	CIRCUIT BREAKER
	THERMAL MAGNETIC CIRCUIT BREAKER
	FUSE
	TRANSIENT VOLTAGE SURGE SUPPRESSOR OR SURGE PROTECTOR DEVICE
	GROUND - GROUND ROD, GROUNDING ELECTRODE, OR AT EARTH POTENTIAL
	INDICATING LIGHT
	MOTOR
	LOAD, MOTOR, # = HORSEPOWER
	ELECTRIC UTILITY METER BASE
	JUNCTION BOX WITH SPLICE
	EQUIPMENT, XXX = DEVICE DESCRIPTION
	GROUND BUS OR TERMINAL
	NEUTRAL BUS
	PANELBOARD WITH MAIN LUGS
	PANELBOARD WITH MAIN BREAKER
	FUSE PANEL WITH MAIN FUSE PULLOUT
	DUPLEX RECEPTACLE 120V SINGLE PHASE GROUNDING TYPE
	CONTROL STATION
	TRANSFER SWITCH
	ENGINE GENERATOR SET

ELECTRICAL LEGEND - SCHEMATIC	
	NORMALLY OPEN (N.O.) CONTACT
	NORMALLY CLOSED (N.C.) CONTACT
	STARTER COIL, * = STARTER NUMBER
	OVERLOAD RELAY CONTACT
	CONTROL RELAY, * = CONTROL RELAY NUMBER
	RELAY, * = RELAY NUMBER
	TOGGLE SWITCH / 2 POSITION SWITCH
	2-POSITION SELECTOR SWITCH
	3-POSITION SELECTOR SWITCH (H-O-A SHOWN)
	2 POLE DISCONNECT SWITCH
	3 POLE DISCONNECT SWITCH
	PHOTOCELL
	TERMINAL BLOCK, * = TERMINAL NUMBER
	DEVICE TERMINAL, * = DEVICE TERMINAL NUMBER
	INTERNAL PANEL WIRING
	FIELD WIRING
	FUSE
	GROUND BUS OR TERMINAL
	NEUTRAL BUS
	GROUND, GROUND ROD, GROUND BUS
	INDUSTRIAL CONTROL RELAY OR LIGHTING CONTACTOR
	S1 CUTOUT HANDLE REMOVED
	S1 CUTOUT HANDLE INSERTED
	N.O. THERMAL SWITCH
	N.C. THERMAL SWITCH
	L-830 SERIES ISOLATION TRANSFORMER

ELECTRICAL ABBREVIATIONS	
A.F.F.	ABOVE FINISHED FLOOR
A, AMP	AMPERES
ATS	AUTOMATIC TRANSFER SWITCH
AWG	AMERICAN WIRE GAUGE
BKR	BREAKER
C	CONDUIT
CB	CIRCUIT BREAKER
CKT	CIRCUIT
CR	CONTROL RELAY
CU	COPPER
DPDT	DOUBLE POLE DOUBLE THROW
DPST	DOUBLE POLE SINGLE THROW
EM	EMERGENCY
EMT	ELECTRICAL METALLIC TUBING
ENCL	ENCLOSURE
EP	EXPLOSION PROOF
ES	EMERGENCY STOP
ETL	INTERTEK - ELECTRICAL TESTING LABS
ETM	ELAPSE TIME METER
GFCI	GROUND FAULT CIRCUIT INTERRUPTER
GFI	GROUND FAULT INTERRUPTER
GND	GROUND
GRSC	GALVANIZED RIGID STEEL CONDUIT
HID	HIGH INTENSITY DISCHARGE
HOA	HAND OFF AUTOMATIC
HP	HORSEPOWER
HPS	HIGH PRESSURE SODIUM
J	JUNCTION BOX
KVA	KILOVOLT AMPERE(S)
KW	KILOWATTS
LC	LIGHTING CONTACTOR
LTFMC	LIQUID TIGHT FLEXIBLE METAL CONDUIT (UL LISTED)
LTC	LIGHTING
LP	LIGHTING PANEL
MAX	MAXIMUM
MCB	MAIN CIRCUIT BREAKER
MCM	THOUSAND CIRCULAR MIL
MDP	MAIN DISTRIBUTION PANEL
MFR	MANUFACTURER
MH	METAL HALIDE
MIN	MINIMUM
MLO	MAIN LUGS ONLY
NEC	NATIONAL ELECTRICAL CODE (NFPA 70)
NC	NORMALLY CLOSED
NO	NORMALLY OPEN
NTS	NOT TO SCALE
OHE	OVERHEAD ELECTRIC
OL	OVERLOAD

ELECTRICAL ABBREVIATIONS (CONTINUED)	
PB	PULL BOX
PC	PHOTO CELL
PDB	POWER DISTRIBUTION BLOCK
PNL	PANEL
RPT	RECEPTACLE
R	RELAY
S	STARTER
SPD	SURGE PROTECTION DEVICE
SPST	SINGLE POLE SINGLE THROW
TVSS	TRANSIENT VOLTAGE SURGE SUPPRESSOR
TYP	TYPICAL
UG	UNDERGROUND
UGE	UNDERGROUND ELECTRIC
UL	UNDERWRITER'S LABORATORIES
V	VOLTS
W/	WITH
W/O	WITHOUT
WP	WEATHER PROOF
XFER	TRANSFER
XFR	TRANSFORMER

AIRPORT EQUIPMENT/FACILITY ABBREVIATIONS	
ASOS	AUTOMATED SURFACE OBSERVING SYSTEM
ATCT	AIR TRAFFIC CONTROL TOWER
AMOS	AUTOMATED WEATHER OBSERVING SYSTEM
CCR	CONSTANT CURRENT REGULATOR
DME	DISTANCE MEASURING EQUIPMENT
FAR	FEDERAL AVIATION REGULATION
GS	GLIDE SLOPE FACILITY
HRLL	HIGH INTENSITY RUNWAY LIGHT
ILS	INSTRUMENT LANDING SYSTEM
IM	INNER MARKER
LIR	LOW IMPACT-RESISTANT
LOC	LOCALIZER FACILITY
MALS	MEDIUM INTENSITY APPROACH LIGHTING SYSTEM
MALS-R	MEDIUM INTENSITY APPROACH LIGHTING SYSTEM WITH RUNWAY ALIGNMENT INDICATING LIGHTS
MRL	MEDIUM INTENSITY RUNWAY LIGHT
MTL	MEDIUM INTENSITY TAXIWAY LIGHT
NDB	NON-DIRECTIONAL BEACON
PAPI	PRECISION APPROACH PATH INDICATOR
PLASI	PULSE LIGHT APPROACH SLOPE INDICATOR
RAIL	RUNWAY ALIGNMENT INDICATING LIGHTS
REL	RUNWAY END IDENTIFIER LIGHT
RVR	RUNWAY VISUAL RANGE
VADI	VISUAL APPROACH DESCENT INDICATOR
VASI	VISUAL APPROACH SLOPE INDICATOR
VOR	VERY HIGH FREQUENCY OMNIDIRECTIONAL RANGE FACILITY
WC	WIND CONE

NOTES:

- ALL ELECTRICAL EQUIPMENT SHALL BE INSTALLED IN CONFORMANCE WITH NFPA 70-NATIONAL ELECTRIC CODE (NEC) MOST CURRENT ISSUE IN FORCE, THE RESPECTIVE EQUIPMENT MANUFACTURER'S DIRECTIONS AND ALL OTHER APPLICABLE LOCAL CODES, LAWS, ORDINANCES, AND REQUIREMENTS IN FORCE. ANY INSTALLATIONS WHICH VOID THE U.L. LISTING, ETL LISTING (OR OTHER THIRD PARTY LISTING) AND/OR THE MANUFACTURER'S WARRANTY OF A DEVICE WILL NOT BE PERMITTED.
- CONTRACTOR SHALL COORDINATE WORK AND ANY POWER OUTAGES WITH THE RESPECTIVE FACILITY OWNER PERSONNEL AND THE AIRPORT MANAGER.
- COLOR CODE PHASE AND NEUTRAL CONDUCTOR INSULATION FOR NO. 6 AWG OR SMALLER. PROVIDE COLORED INSULATION OR COLORED MARKING TAPE FOR PHASE AND NEUTRAL CONDUCTORS FOR NO. 4 AWG AND LARGER. INSULATED GROUND CONDUCTORS SHALL HAVE GREEN COLORED INSULATION FOR ALL CONDUCTOR AWG AND/OR KCMIL TO COMPLY WITH NEC 250.119. NEUTRAL CONDUCTORS SHALL HAVE WHITE COLORED INSULATION FOR NO. 6 AWG AND SMALLER TO MEET THE REQUIREMENTS OF NEC 200.6. STANDARD COLORS FOR POWER WIRING AND BRANCH CIRCUITS SHALL BE AS FOLLOWS:  

120/240 VAC, 1 PHASE, 3 WIRE  
 PHASE A       BLACK  
 PHASE B       RED  
 NEUTRAL       WHITE  
 GROUND       GREEN
- SEE RESPECTIVE SITE PLANS FOR SITE LEGEND INFORMATION.
- LTFMC DENOTES LIQUID TIGHT FLEXIBLE METAL CONDUIT UL LISTED, SUNLIGHT RESISTANT, & SUITABLE FOR GROUNDING. LIQUID TIGHT FLEXIBLE METAL CONDUIT AND ASSOCIATED FITTINGS SHALL BE U.L. LISTED TO MEET THE REQUIREMENTS OF NEC 350.6. LIQUID TIGHT FLEXIBLE METAL CONDUIT THAT IS USED FOR FLEXIBILITY (INCLUDING CONNECTIONS TO COR'S & TRANSFORMERS) SHALL REQUIRE AN EXTERNAL BONDING JUMPER OR INTERNAL EQUIPMENT GROUNDING CONDUCTOR PER NEC 350.60. EXTERNAL BONDING JUMPERS USED WITH CCR INSTALLATIONS SHALL BE #6 AWG COPPER (MINIMUM). DO NOT INSTALL LTFMC THAT IS NOT UL LISTED.
- ALL ELECTRICAL INSTALLATIONS AT OR ASSOCIATED WITH THE FUEL FACILITY IN CLASSIFIED HAZARDOUS LOCATIONS (CLASS I, DIV. 1 OR 2, GROUP D) SHALL BE SUITABLE FOR THE RESPECTIVE ENVIRONMENT AND SHALL CONFORM TO THE APPLICABLE SECTIONS OF NEC (MOST CURRENT ISSUE) INCLUDING, BUT NOT LIMITED TO, ARTICLES 500, 501, 514 AND 515 AS WELL AS ALL MANUFACTURER REQUIREMENTS, AND ALL LOCAL CODES, LAWS, ORDINANCES, AND REQUIREMENTS IN FORCE.

TR005

CONSTRUCT NEW VAULT	ELECTRICAL LEGEND AND ABBREVIATIONS	4 4 of 24 sheets	TRI-TOWNSHIP AIRPORT SAVANNA, CARROLL COUNTY ILLINOIS	A.I.P. PROJ.: 3-17-0091-B14 IL PROJ.: SFY-3782	REVISION DATE
HANSON Hanson Professional Services Inc. 1525 South State Street Springfield, Illinois 62768-2886 Offices Nationwide		HEL Project No. 07A0144D.0800 Filename E-001.DWG Scale NONE Date 05/13/08		LAYOUT 05/03/07 DRAWN MV 05/18/07 REVIEWED CAH 02/08/08	

MAY 13, 2008 3:09 PM HINT001214  
 I:\AIRPORTS\SAVANNA\07A0144\CAD\SHEETS\R-12\CON.DWG - Layout1

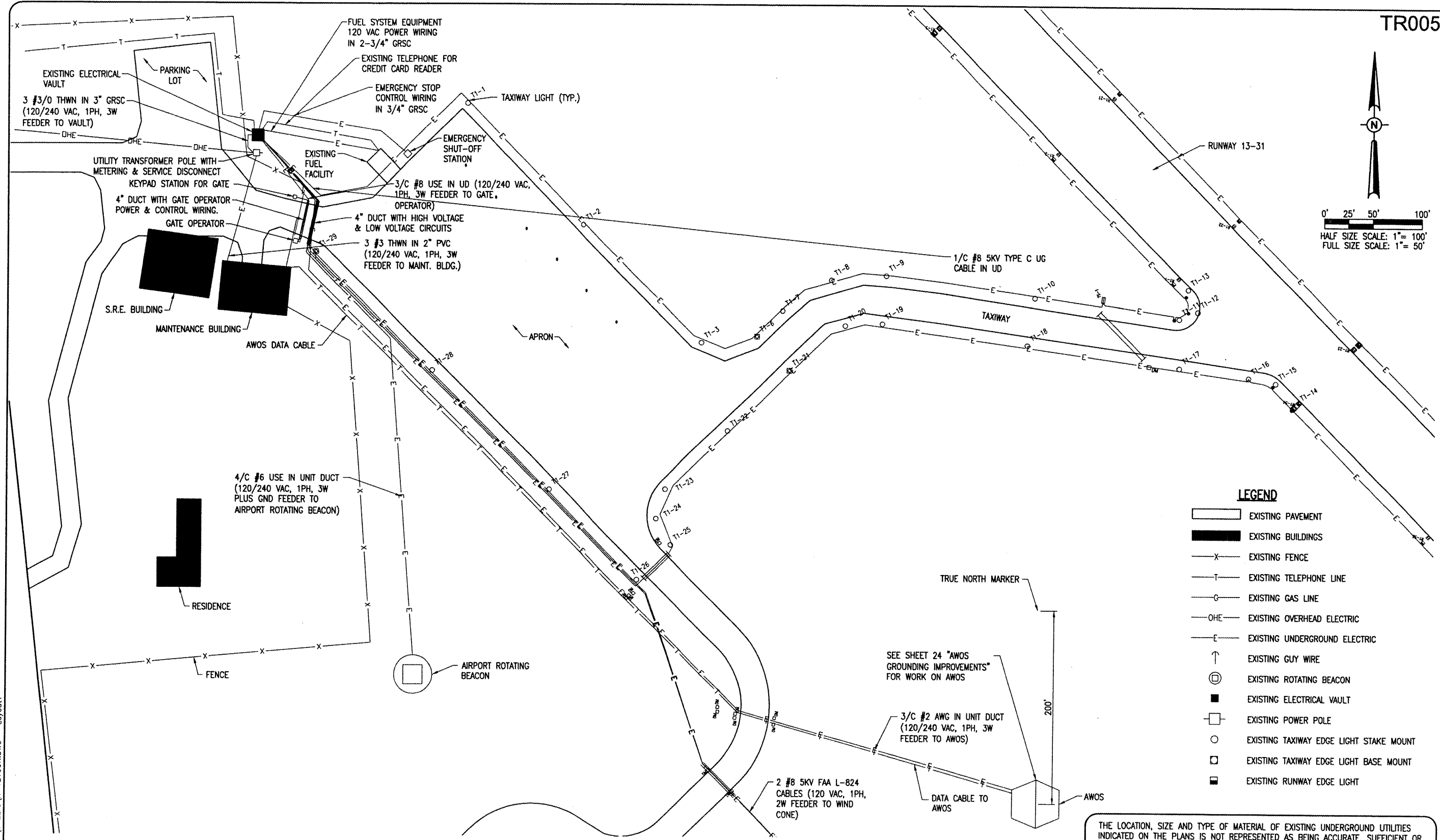

TR005

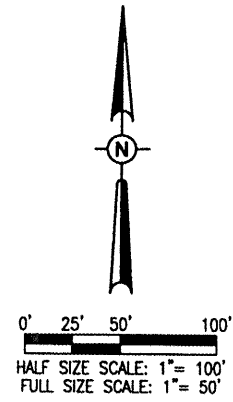

**LEGEND**

- EXISTING PAVEMENT
- EXISTING BUILDINGS
- EXISTING FENCE
- EXISTING TELEPHONE LINE
- EXISTING GAS LINE
- EXISTING OVERHEAD ELECTRIC
- EXISTING UNDERGROUND ELECTRIC
- EXISTING GUY WIRE
- EXISTING ROTATING BEACON
- EXISTING ELECTRICAL VAULT
- EXISTING POWER POLE
- EXISTING TAXIWAY EDGE LIGHT STAKE MOUNT
- EXISTING TAXIWAY EDGE LIGHT BASE MOUNT
- EXISTING RUNWAY EDGE LIGHT

THE LOCATION, SIZE AND TYPE OF MATERIAL OF EXISTING UNDERGROUND UTILITIES INDICATED ON THE PLANS IS NOT REPRESENTED AS BEING ACCURATE, SUFFICIENT OR COMPLETE. IT SHALL BE THE CONTRACTOR'S RESPONSIBILITY TO DETERMINE THE ACTUAL LOCATION OF ALL SUCH FACILITIES, INCLUDING SERVICE CONNECTIONS TO UNDERGROUND UTILITIES. PRIOR TO CONSTRUCTION, THE CONTRACTOR SHALL NOTIFY THE UTILITY COMPANIES OF HIS OPERATIONAL PLANS AND SHALL OBTAIN FROM THE RESPECTIVE UTILITY COMPANIES DETAILED INFORMATION AND ASSISTANCE RELATIVE TO THE LOCATION OF THEIR FACILITIES AND THE WORKING SCHEDULE OF THE COMPANIES FOR REMOVAL OR ADJUSTMENT WHERE REQUIRED. IN THE EVENT AN UNEXPECTED UTILITY INTERFERENCE IS ENCOUNTERED DURING CONSTRUCTION, THE CONTRACTOR SHALL IMMEDIATELY NOTIFY THE UTILITY COMPANY OF JURISDICTION. THE ENGINEER SHALL ALSO BE IMMEDIATELY NOTIFIED. ANY SUCH MAINS AND SERVICES SHALL BE RESTORED TO SERVICE AT ONCE AND PAID FOR BY THE CONTRACTOR AT NO ADDITIONAL COST TO THE CONTRACT.

CALL J.U.L.I.E. FOR UTILITY INFORMATION AT 1-800-892-0123.

DATE	REVISION	BY

TRI-TOWNSHIP AIRPORT  
 SAVANNA, CARROLL COUNTY  
 ILLINOIS

IL PROJ.: SFY-3782 A.I.P. PROJ.: 3-17-0091-B14

FILE: 07A0144D_0800	LAYOUT	MDR	12/19/07
FILE: R-12\CON.DWG	DRAWN	MDR	12/19/07
SCALE: 1"=50'	REVIEWED	CAH	02/08/08
DATE: 05/13/08			



**CONSTRUCT**  
 NEW VAULT

**EXISTING**  
 AIRPORT VAULT  
 SITE PLAN

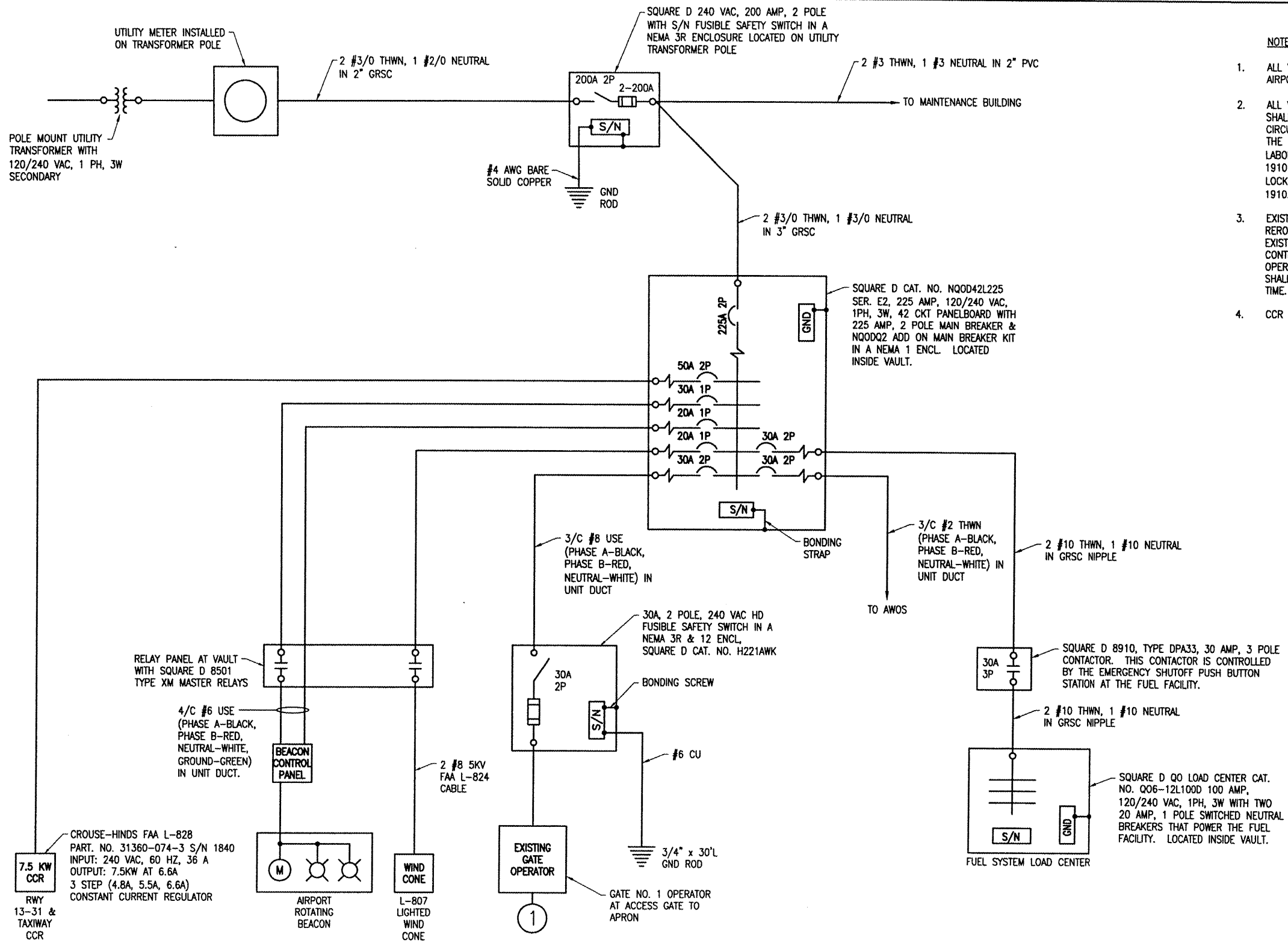

EXISTING VAULT ELECTRICAL ONE-LINE DIAGRAM

NOTES

1. ALL VAULT WORK AND/OR POWER OUTAGES SHALL BE COORDINATED WITH THE AIRPORT MANAGER.
2. ALL VAULT WORK, POWER OUTAGES, AND/OR SHUT DOWN OF EXISTING SYSTEMS SHALL BE COORDINATED WITH THE AIRPORT MANAGER. ONCE SHUT DOWN, THE CIRCUITS SHALL BE LABELED AS SUCH TO PREVENT ACCIDENTAL ENERGIZING OF THE RESPECTIVE CIRCUITS. ALL PERSONNEL SHALL FOLLOW U.S. DEPARTMENT OF LABOR OCCUPATIONAL SAFETY & HEALTH ADMINISTRATION (OSHA) 29 CFR PART 1910 OCCUPATIONAL SAFETY & HEALTH STANDARDS FOR ELECTRICAL SAFETY AND LOCKOUT/TAGOUT PROCEDURES INCLUDING, BUT NOT LIMITED TO, 29 CFR SECTION 1910.147 THE CONTROL OF HAZARDOUS ENERGY (LOCKOUT/TAGOUT).
3. EXISTING AIRFIELD CIRCUITS SHALL BE LOCATED, IDENTIFIED, DISCONNECTED, REROUTED & RECONNECTED TO THE NEW VAULT AS DETAILED HEREIN. ALL EXISTING AIRFIELD LIGHTING SYSTEMS SHALL BE OPERABLE DURING NIGHTFALL. CONTRACTOR SHALL PROVIDE ALL TEMPORARY WORK AS NECESSARY TO MAINTAIN OPERATION OF THE AIRFIELD LIGHTING SYSTEMS AT NIGHTFALL. CONTRACTOR SHALL COORDINATE TRANSFER OF EXISTING AIRFIELD CIRCUITS TO MINIMIZE DOWN TIME.
4. CCR DENOTES CONSTANT CURRENT REGULATOR.

TR005

DATE	REVISION	BY

TRI-TOWNSHIP AIRPORT  
 SAVANNA, CARROLL COUNTY  
 ILLINOIS

IL PROJ.: SFY-3782 A.I.P. PROJ.: 3-17-0091-814

REL. PROJECT No. 07A0144D_0800	FILENAME E-601.DWG	DATE 05/13/08
SHEET NONE	LAYOUT KNL	01/02/08
SCALE NONE	DRAWN MW	01/03/08
DATE 05/13/08	REVIEWED CAH	02/08/08

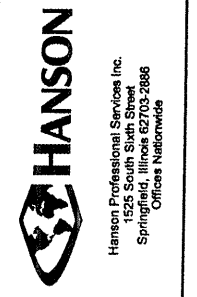

CONSTRUCT  
 NEW VAULT

EXISTING VAULT  
 ELECTRICAL ONE-LINE  
 DIAGRAM



THE LOCATION, SIZE AND TYPE OF MATERIAL OF EXISTING UNDERGROUND UTILITIES INDICATED ON THE PLANS IS NOT REPRESENTED AS BEING ACCURATE, SUFFICIENT OR COMPLETE. IT SHALL BE THE CONTRACTOR'S RESPONSIBILITY TO DETERMINE THE ACTUAL LOCATION OF ALL SUCH FACILITIES, INCLUDING SERVICE CONNECTIONS TO UNDERGROUND UTILITIES. PRIOR TO CONSTRUCTION, THE CONTRACTOR SHALL NOTIFY THE UTILITY COMPANIES OF HIS OPERATIONAL PLANS AND SHALL OBTAIN FROM THE RESPECTIVE UTILITY COMPANIES DETAILED INFORMATION AND ASSISTANCE RELATIVE TO THE LOCATION OF THEIR FACILITIES AND THE WORKING SCHEDULE OF THE COMPANIES FOR REMOVAL OR ADJUSTMENT WHERE REQUIRED. IN THE EVENT AN UNEXPECTED UTILITY INTERFERENCE IS ENCOUNTERED DURING CONSTRUCTION, THE CONTRACTOR SHALL IMMEDIATELY NOTIFY THE UTILITY COMPANY OF JURISDICTION. THE ENGINEER SHALL ALSO BE IMMEDIATELY NOTIFIED. ANY SUCH MAINS AND SERVICES SHALL BE RESTORED TO SERVICE AT ONCE AND PAID FOR BY THE CONTRACTOR AT NO ADDITIONAL COST TO THE CONTRACT.

CALL J.U.L.I.E. FOR UTILITY INFORMATION AT 1-800-892-0123.

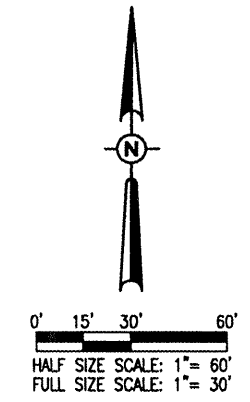

NOTES

- 1. HIGH VOLTAGE AND LOW VOLTAGE CABLES SHALL NOT BE INSTALLED IN THE SAME HANDHOLE, WIREWAY, OR DUCT.

LEGEND

- EXISTING PAVEMENT
- EXISTING BUILDINGS
- EXISTING FENCE
- EXISTING TELEPHONE LINE
- EXISTING GAS LINE
- EXISTING OVERHEAD ELECTRIC
- EXISTING UNDERGROUND ELECTRIC
- EXISTING GUY WIRE
- EXISTING ROTATING BEACON
- EXISTING ELECTRICAL VAULT
- EXISTING POWER POLE
- EXISTING TAXIWAY EDGE LIGHT STAKE MOUNT
- EXISTING TAXIWAY EDGE LIGHT BASE MOUNT
- EXISTING RUNWAY EDGE LIGHT
- PROPOSED CABLE IN DUCT
- PROPOSED 1/C NO. 8 5KV CABLE IN UD
- PROPOSED DUCT
- PROPOSED ELECTRICAL HANDHOLE
- PROPOSED VAULT

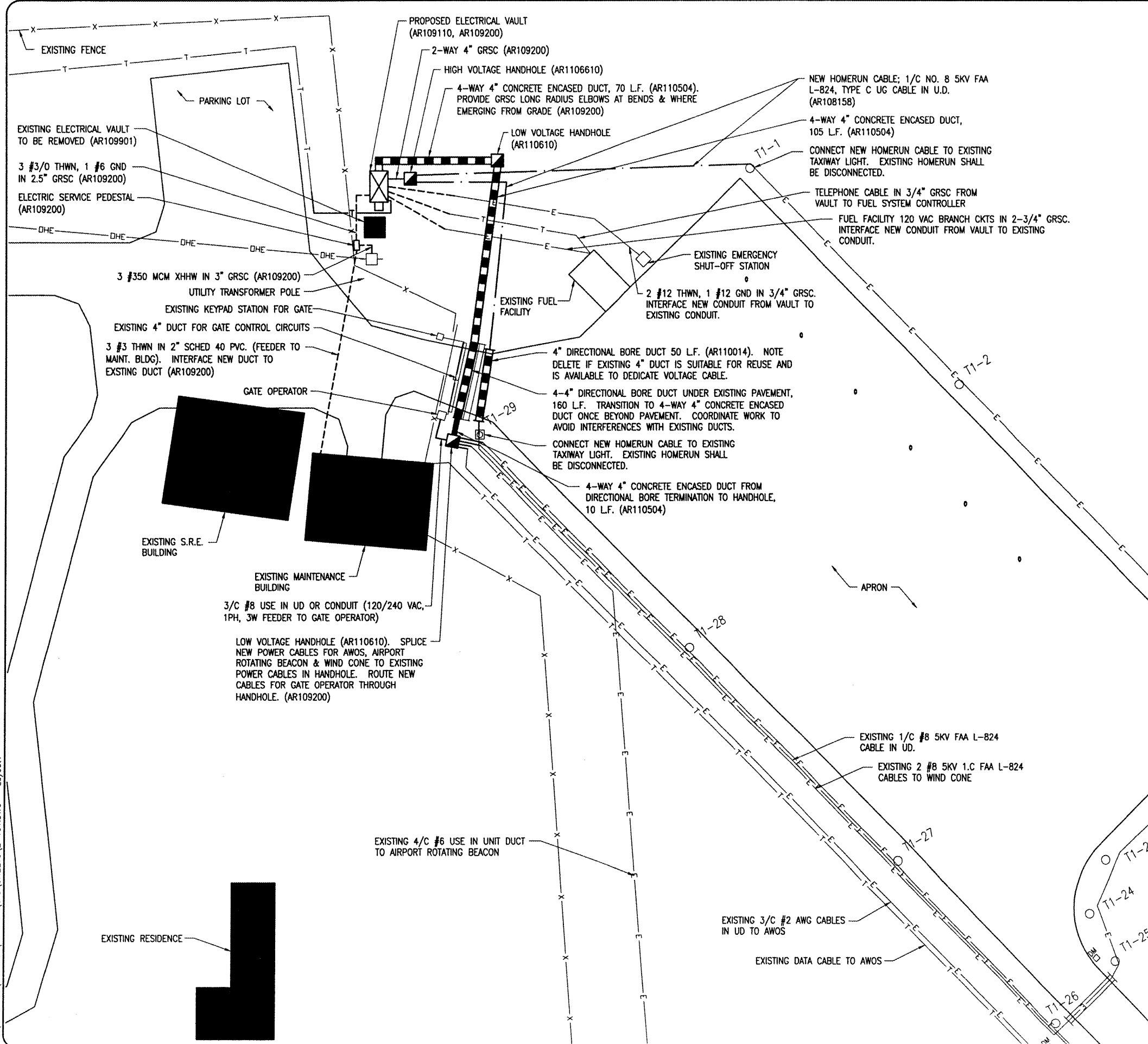

Table with columns: DATE, REVISION, BY. Contains revision history.

TRI-TOWNSHIP AIRPORT SAVANNA, CARROLL COUNTY ILLINOIS

Table with columns: REVISED, DATE, BY. Contains drawing revision details.



CONSTRUCT NEW VAULT PROPOSED AIRPORT VAULT SITE PLAN

MAY 13, 2008 3:11 PM HINT001214 I:\AIRPORTS\SAVANNA\07A0144\CAD\SHEETS\E-101.DWG - Layout1

MAY 13, 2008 3:12 PM HINT001214  
 I:\AIRPORTS\SAVANNA\07A0144\CAD\SHEETS\EP-101.DWG - Layout1

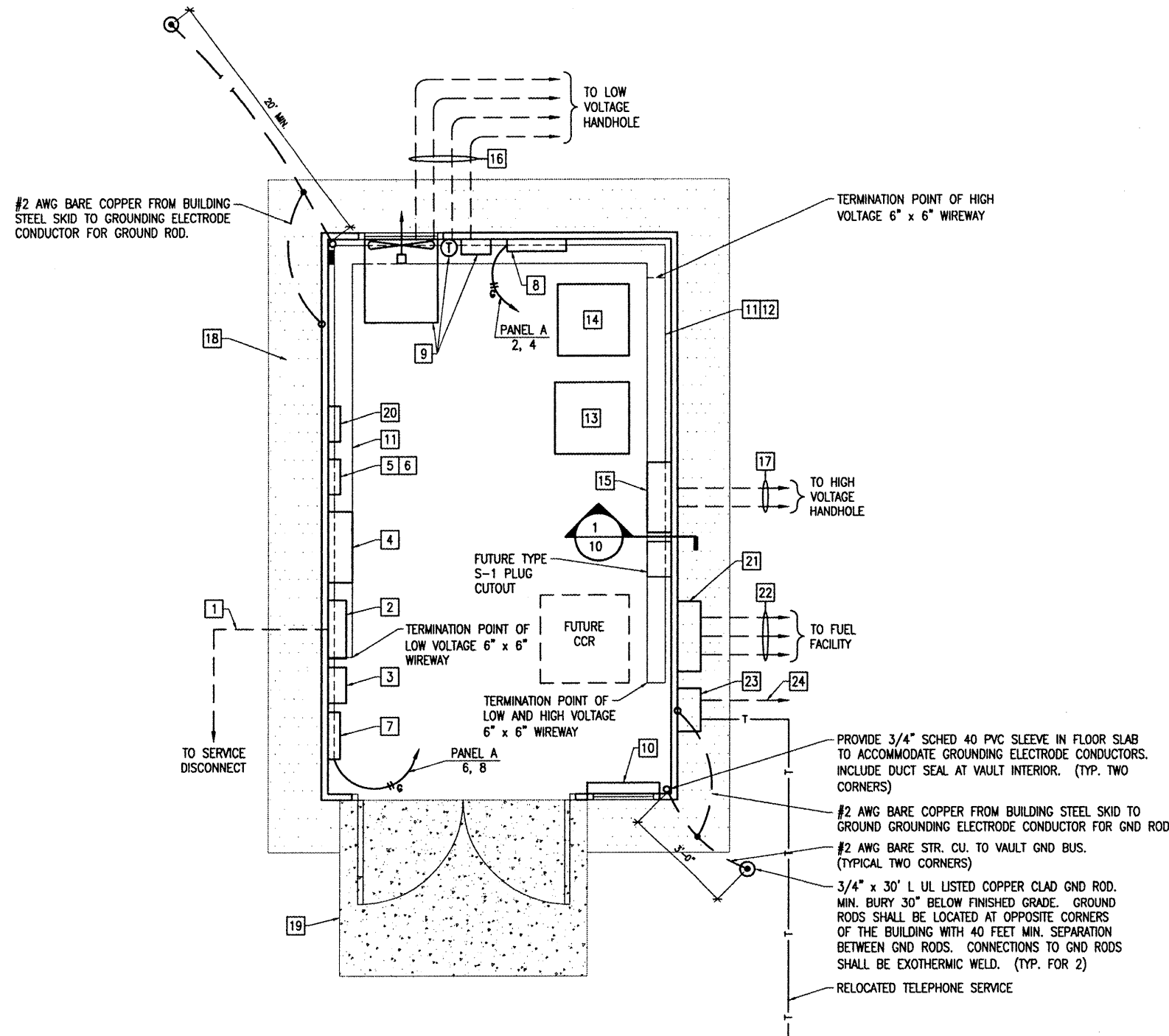

**VAULT ELECTRICAL EQUIPMENT PLAN**  
 SCALE 1/2"=1'-0"  
 1 0 2 4 FEET

**KEYED NOTES**

- 1 2 #3/0 THWN, 1 #3/0 THWN NEUTRAL, 1 #6 GND IN 2.5" GRSC FROM SERVICE BREAKER TO VAULT PANEL.
- 2 VAULT PANEL. SEE VAULT PANEL SCHEDULE.
- 3 AC SURGE PROTECTOR/TVSS, SEE NEW VAULT ELECTRICAL ONE LINE DIAGRAM.
- 4 RELAY/LIGHTING CONTACTOR PANEL. SEE AIRFIELD LIGHTING WIRING SCHEMATIC AND RELAY/CONTACTOR PANEL DETAIL. MOUNT PHOTOCCELL ON ROOF. FIELD VERIFY LOCATION FOR PROPER CONTROL AND OPERATION.
- 5 L-854 RADIO CONTROL UNIT WITH RELAY INTERFACE PANEL BELOW. EXTEND GRSC & RADIO ANTENNA CABLE AND MOUNT ANTENNA ABOVE THE VAULT BUILDING ROOF AS REQUIRED FOR PROPER OPERATION.
- 6 RELAY INTERFACE PANEL (BELOW L-854 RADIO CONTROL UNIT). SEE AIRFIELD LIGHTING WIRING SCHEMATIC FOR WIRING REQUIREMENTS.
- 7 ELECTRIC WALL HEATER EH-1, 3000 WATT, 240 VAC, 1 PHASE, SUITABLE FOR SURFACE MOUNTING WITH INTEGRAL THERMOSTAT, Q-MARK MODEL CWH3407, OR APPROVED EQUAL. BOTTOM OF HEATER SHALL BE 3" (MIN.) ABOVE THE UPPER ELECTRICAL WIREWAY.
- 8 ELECTRIC WALL HEATER EH-2, 2000 WATT, 240 VAC, 1 PHASE, SUITABLE FOR SURFACE MOUNTING WITH INTEGRAL THERMOSTAT, Q-MARK MODEL CWH3404, OR APPROVED EQUAL. BOTTOM OF HEATER SHALL BE 3" (MIN.) ABOVE THE UPPER ELECTRICAL WIREWAY. COORDINATE WITH CCR INSTALLATION & FAN INSTALLATION. LOCATE HEATER ON WALL SUCH THAT IT IS NOT DIRECTLY BEHIND CCR.
- 9 EXHAUST FAN EF-1, 2000 CFM AT .25" STATIC PRESSURE WITH 1/2 HP, 120 VAC MOTOR, COOK MODEL 18S10D, OR APPROVED EQUAL. INCLUDE WALL HOUSING WITH GUARD, GRAVITY BACK DRAFT DAMPER, ALUMINUM WEATHER-HOOD PAINTED TO MATCH BUILDING EXTERIOR, STAINLESS STEEL INSECT SCREEN, AND FRACTIONAL HP ELECTRICAL DISCONNECT. INSTALL FAN AS HIGH AS POSSIBLE. PROVIDE 120 VAC THERMOSTAT WITH CONTACTOR AND AUTO-OFF-MANUAL CONTROL SWITCH AT 48" AFF. MOUNT THERMOSTAT ON 2" THICK INSULATED BASE. SEE EXHAUST FAN CONTROL SCHEMATIC FOR WIRING REQUIREMENTS.
- 10 INTAKE LOUVER L-1, 24" WIDE BY 48" HIGH INTAKE LOUVER WITH STAINLESS STEEL INSECT SCREEN, 120 VAC MOTORIZED DAMPER WITH LIMIT SWITCH, KYNAR FINISH MATCHING BUILDING EXTERIOR, RUSKIN MODEL ELF375DX, OR APPROVED EQUAL. SEE EXHAUST FAN CONTROL SCHEMATIC FOR WIRING REQUIREMENTS.
- 11 6" BY 6" LOW VOLTAGE WIREWAY. LABEL "LOW VOLTAGE" EVERY 4 FEET. INSTALL ABOVE HIGH VOLTAGE WIREWAY.
- 12 6" BY 6" HIGH VOLTAGE WIREWAY. LABEL "HIGH VOLTAGE" EVERY 4 FEET. INSTALL BELOW LOW VOLTAGE WIREWAY.
- 13 EXISTING RUNWAY 13-31 & TAXIWAY CONSTANT CURRENT REGULATOR RELOCATED FROM EXISTING VAULT, (TO SERVE AS SPARE). SEE GENERAL NOTE 1.
- 14 NEW RUNWAY 13-31 & TAXIWAY CONSTANT CURRENT REGULATOR (TO SERVE AS NORMAL UNIT). SEE GENERAL NOTE 1.
- 15 TWO SERIES PLUG CUTOUTS, TYPE S-1, WIRED FOR MANUAL TRANSFER OPERATION WITH ONLY ONE HANDLE PLUG IN A NEMA 1 OR NEMA 12 ENCLOSURE WITH HINGED COVER.
- 16 4-4" GRSC WITH LONG RADIUS GRSC ELBOWS. FROM LOW VOLTAGE WIREWAY TO DUCT BANK. TRANSITION TO 4-WAY CONCRETE ENCASED DUCT AND EXTEND TO LOW VOLTAGE HANDHOLE.
- 17 2-4" GRSC FROM HIGH VOLTAGE WIREWAY TO HIGH VOLTAGE HANDHOLE.
- 18 VEGETATION BARRIER CONSISTING OF A MIN. 3" PEA GRAVEL SURFACE OVER FILTER OR LANDSCAPING FABRIC. PROPOSED SURFACE TREATMENT WILL COVER ENTIRE AREA BENEATH VAULT STRUCTURE AS WELL AS 18" AROUND THE PERIMETER OF THE BUILDING EDGE. THE STONE AND FABRIC AS WELL AS ANY EQUIPMENT AND LABOR REQUIRED TO COMPLETE THIS TASK WILL BE CONSIDERED INCIDENTAL TO THE INSTALLATION OF THE PROPOSED ELECTRICAL VAULT AND NO ADDITIONAL COMPENSATION WILL BE ALLOWED.
- 19 ENTRANCE PAD CONSTRUCTED OF 6" CONCRETE SLAB W/6X6-W5XW5 WELDED WIRE FABRIC ON A COMPACTED SUBGRADE. MIN. DIMENSIONS OF PAD WILL BE 7'Wx5'Dx6"H, SLOPED AT A MIN. OF 0.5"/FT AWAY FROM THE VAULT ENTRANCE. PCC USED TO CONSTRUCT THE PAD WILL CONFORM TO ITEM 610. ALL MATERIALS, LABOR AND EQUIPMENT USED TO CONSTRUCT THE PAD INCLUDING ANY GRADING REQUIRED WILL BE CONSIDERED INCIDENTAL TO THE CONSTRUCTION OF THE PROPOSED ELECTRICAL VAULT AND NO ADDITIONAL COMPENSATION WILL BE ALLOWED.
- 20 FUEL FACILITY LOAD CENTER. SEE FUEL FACILITY LOAD CENTER SCHEDULE.
- 21 NEMA 4X SS J-BOX FOR FUEL FACILITY CIRCUITS. SEE SHEET 19 FOR DETAILS.
- 22 FUEL FACILITY CIRCUITS IN 3/4" GRSC.
- 23 RELOCATED TELEPHONE NETWORK INTERFACE BOX.
- 24 TELEPHONE CABLE IN 3/4" GRSC TO FUEL SYSTEM CONTROLLER.

**GENERAL NOTES**

1. SEE "NEW VAULT ELECTRICAL ONE LINE DIAGRAM" FOR LOW VOLTAGE INPUT POWER WIRING REQUIREMENTS TO CCR'S (CONSTANT CURRENT REGULATORS). SEE "HIGH VOLTAGE WIRING SCHEMATIC" FOR CCR OUTPUT WIRING REQUIREMENTS. SEE "AIRFIELD LIGHTING WIRING SCHEMATIC" FOR CCR CONTROL WIRING REQUIREMENTS. PROVIDE 5 FEET MINIMUM CLEAR WORKING SPACE IN FRONT OF EACH CCR AND EACH SERIES PLUG CUTOUT.
2. CONSTANT CURRENT REGULATORS AND THEIR RESPECTIVE SERIES PLUG CUTOUTS SHALL BE CLEARLY LABELED TO IDENTIFY THE RESPECTIVE REGULATOR DESIGNATION, RUNWAY OR TAXIWAY SERVED, POWER SOURCE OR CIRCUIT, AND VOLTAGE SYSTEM.
3. SEE ELEVATION VIEWS FOR ADDITIONAL INFORMATION ON PROPOSED EQUIPMENT LAYOUTS.
4. COORDINATE CONDUIT & SLEEVE ENTRANCES THROUGH FLOOR SLAB AND WALLS.

TR005

BY	REVISION	DATE

TRI-TOWNSHIP AIRPORT  
 SAVANNA, CARROLL COUNTY  
 ILLINOIS

IL PROJ.: SFY-3782 A.I.P. PROJ.: 3-17-0091-B14

Project No. 07A0144D_0800	Scale 1/2"=1'-0"	Date 05/13/08
Drawn KNL	Checked MW	Reviewed CAH
Drawn Date 01/02/08	Checked Date 01/21/08	Reviewed Date 02/08/08



CONSTRUCT  
 NEW VAULT

PROPOSED  
 AIRPORT VAULT  
 EQUIPMENT PLAN



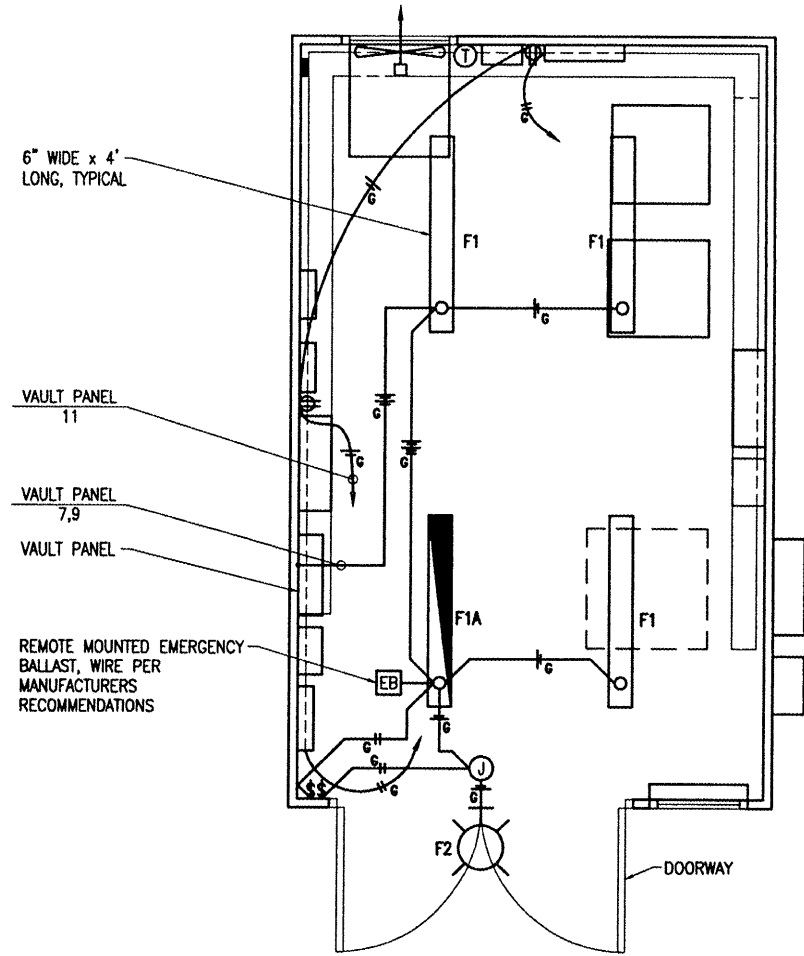

N  
VAULT LIGHTING & RECEPTACLE PLAN  
SCALE 1/2"=1'-0"  
1 0 2 4 FEET

LIGHTING FIXTURE SCHEDULE						
FIXT. TYPE	DESCRIPTION	MANUFACTURER & CATALOG NO.	LAMPS/WATTS	VOLTS	MOUNTING	REMARKS
F1	4 FT. WET LOCATION LISTED ENCLOSED AND GASKETED INDUSTRIAL FLUORESCENT LIGHT FIXTURE, IMPACT RESISTANT, UV RESISTANT REINFORCED POLYESTER FIBERGLASS HOUSING, HIGH IMPACT ACRYLIC DIFFUSER, RAPID START COLD WEATHER 0 DEG. F. ELECTRONIC BALLAST WITH LESS THAN OR EQUAL TO 10% THD.	LITHONIA: DMW-2-32-AR-120-CW-GEB10RS-WLF	2-32W T8 4100K 59 TOTAL INPUT WATTS	120	SURFACE TO HARD CEILING	PROVIDE WET LOCATION FITTINGS INSTALLED IN TOP OF FIXTURE.
F1A	SAME AS F1 EXCEPT PROVIDE AN EMERGENCY BALLAST CAPABLE OF OPERATING 2 LAMPS FOR 90 MINUTES AT 1100-1400 TOTAL LUMENS, BODINE #B50ST. NOTE BALLAST WILL HAVE TO BE REMOTE MOUNTED NEAR FIXTURE AS INDICATED ON THE PLANS.	LITHONIA: DMW-2-32-AR-120-CW-GEB10RS-WLF	2-32W T8 4100K 59 TOTAL INPUT WATTS	120	SURFACE TO HARD CEILING	PROVIDE WET LOCATION FITTINGS INSTALLED IN TOP OF FIXTURE.
F2	COMPACT FLUORESCENT WALL-PAK, ONE PIECE INJECTION MOLDED UV STABILIZED POLYCARBONATE HOUSING, HIGH PERFORMANCE SPECULAR ANODIZED SEGMENTED REFLECTOR, ONE PIECE HIGH TEMPERATURE SILICONE GASKET, MEDIUM BRONZE FINISH, HIGH POWERFACTOR ELECTRONIC BALLAST WITH LESS THAN OR EQUAL TO 10% THD, UL LISTED FOR WET LOCATIONS, FUSED.	LITHONIA: TWA-42TRT-120-SF-CR-DMB-LP1	1-42W TRT 4100K 47 TOTAL INPUT WATTS	120	SURFACE TO WALL ABOVE EXTERIOR DOOR APPROXIMATELY 4 INCHES ABOVE TOP OF DOOR FRAME.	CONNECT TO WALL SWITCH LOCATED ON THE INSIDE OF THE BUILDING.

NOTE  
15 AMP & 20 AMP BRANCH CIRCUITS FOR LIGHTING & RECEPTACLES SHALL USE #12 AWG THWN (MIN.).

DATE	REVISION	BY

TRI-TOWNSHIP AIRPORT  
SAVANNA, CARROLL COUNTY  
ILLINOIS

IL PROJ.: SFY-3782 A.I.P. PROJ.: 3-17-0081-814

HEL Project No. 07A0144D.0800	EL-101.DWG	Scale NONE	Date 05/13/08
LAYOUT	KNL	01/02/08	01/03/08
DRAWN	MV	01/03/08	02/08/08
REVIEWED	CAH	02/08/08	



CONSTRUCT  
NEW VAULT

PROPOSED  
VAULT LIGHTING  
AND RECEPTACLE PLAN

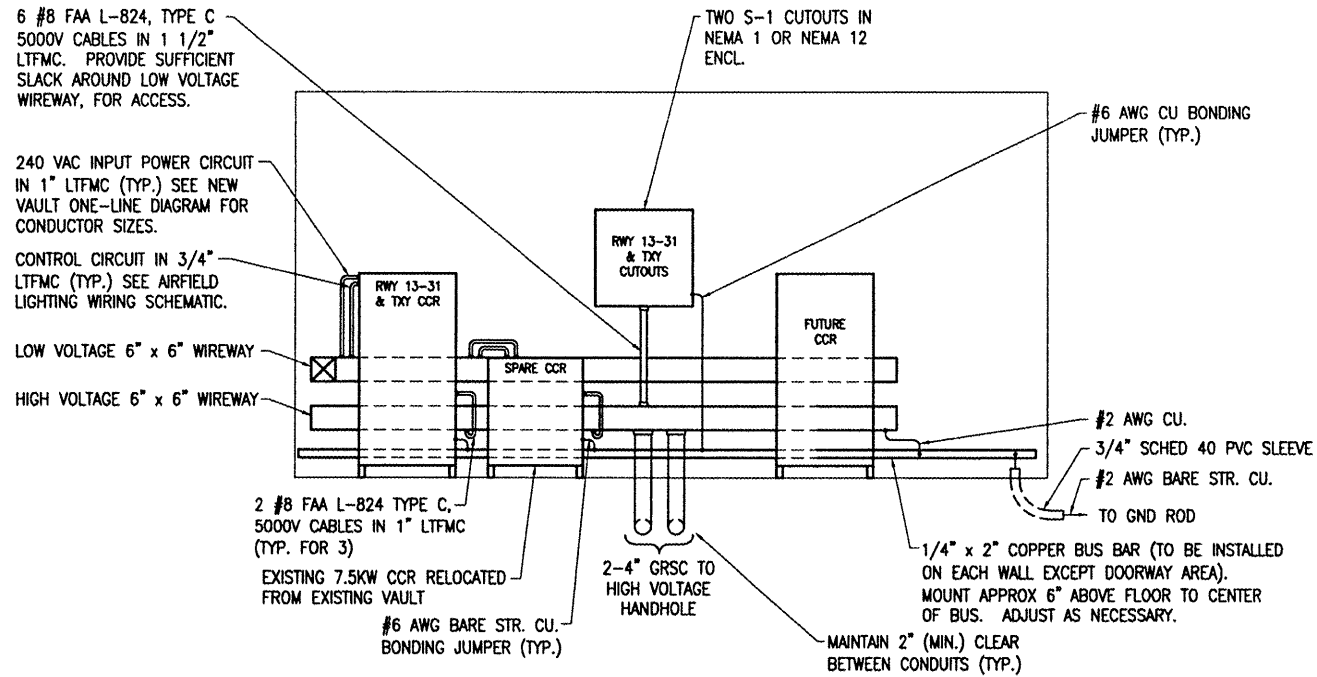

**VAULT EAST WALL ELEVATION**  
SCALE 1/2"=1'-0"  
1 0 2 4 FEET

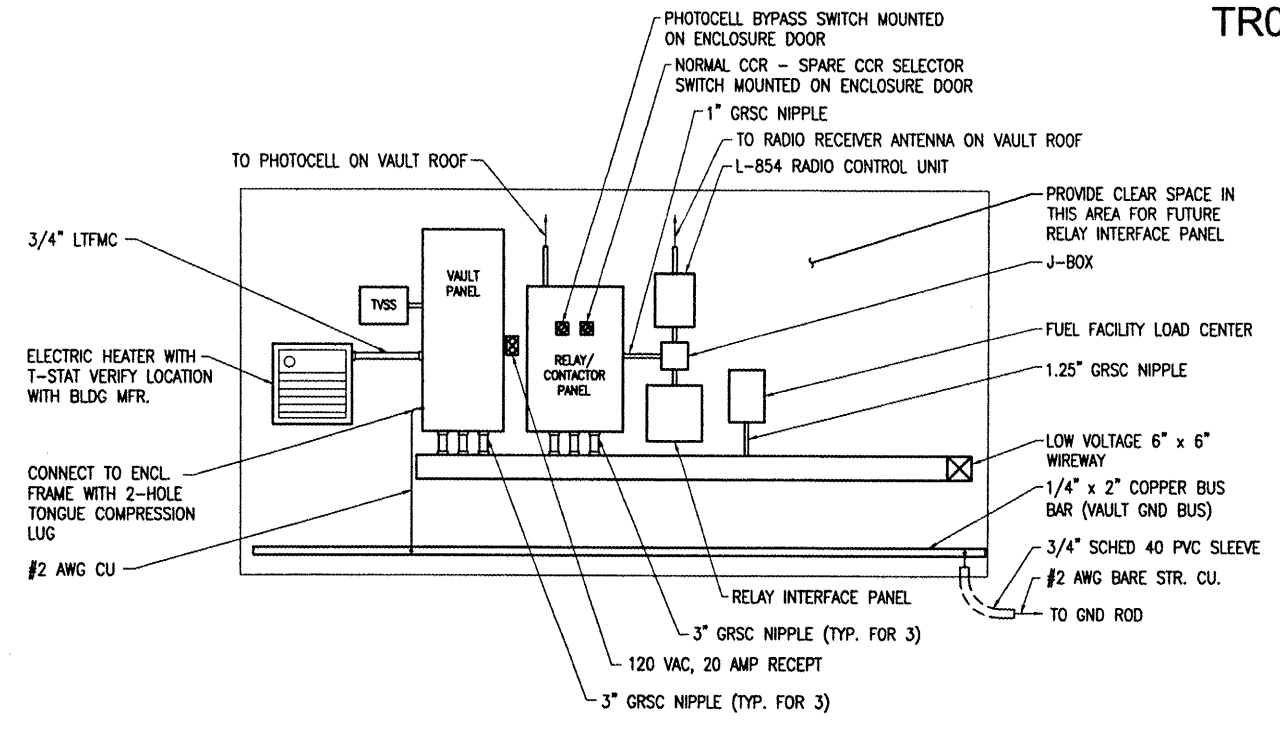

**VAULT WEST WALL ELEVATION**  
SCALE 1/2"=1'-0"  
1 0 2 4 FEET

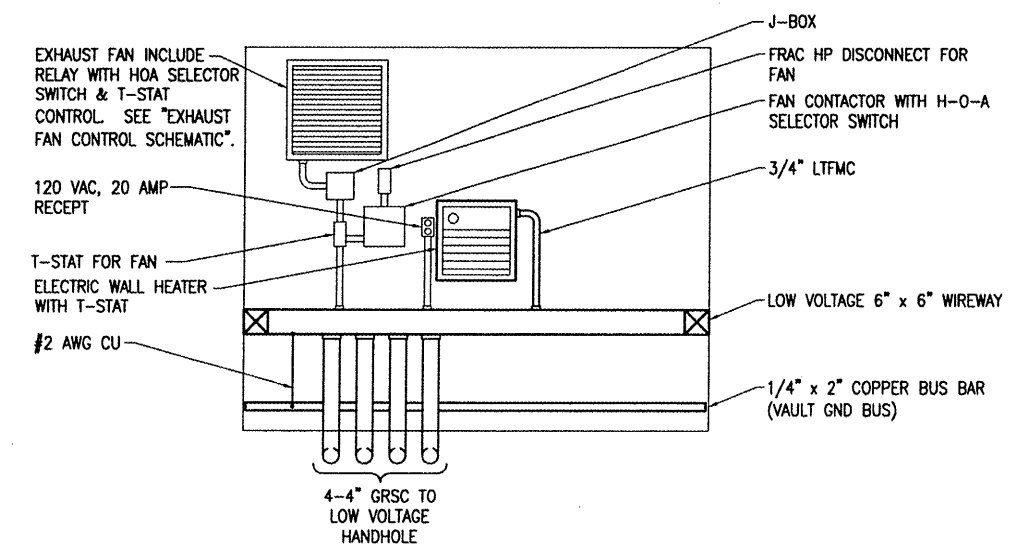

**VAULT NORTH WALL ELEVATION**  
SCALE 1/2"=1'-0"  
1 0 2 4 FEET

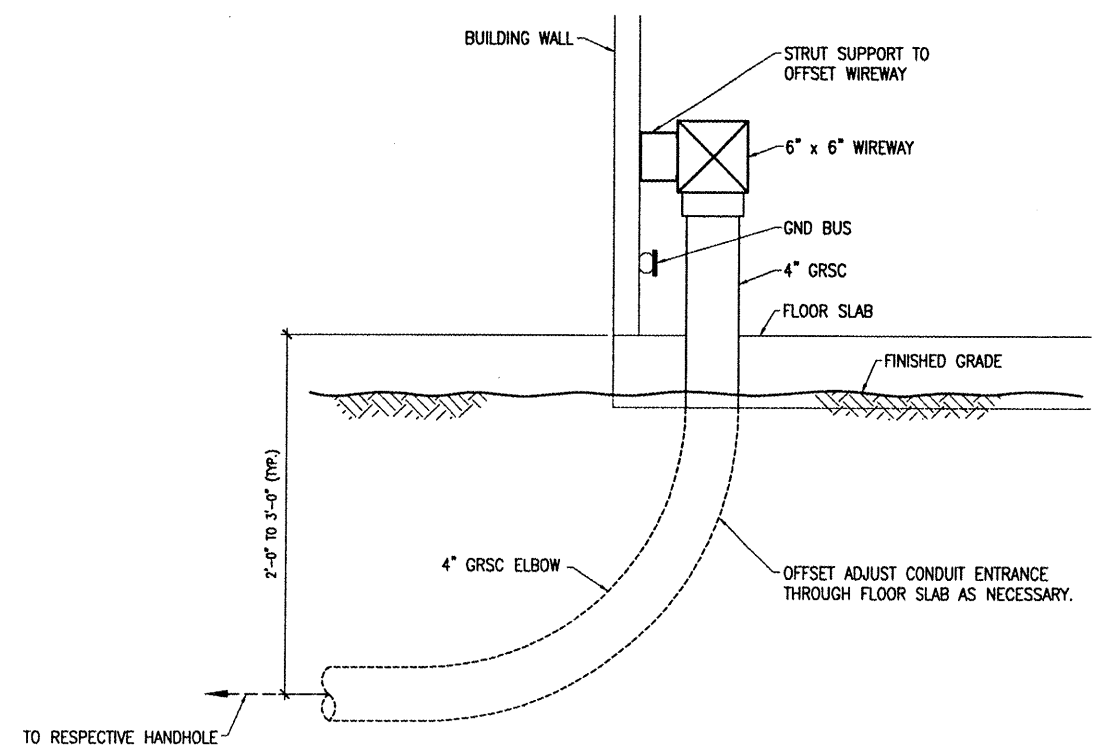

**CONDUIT ENTRANCE DETAIL**  
SCALE 1 1/2"=1'-0"  
0.5 0 1 2 FEET

BY	
REVISION	
DATE	

TRI-TOWNSHIP AIRPORT  
SAVANNA, CARROLL COUNTY  
ILLINOIS

IL PROJ.: SFY-3782 A.I.P. PROJ.: 3-17-0081-B14

FILE PROJECT No.	07A0144D_0800
Drawn	E-201.DWG
Scale	1/2"=1'-0"
Date	05/13/08
LAYOUT	KNL 01/22/08
DRAWN	MY 01/22/08
REVIEWED	CAH 02/08/08



Hanson Professional Services Inc.  
1525 South Sixth Street  
Springfield, Illinois 62703-2886  
Offices Nationwide

CONSTRUCT  
NEW VAULT

PROPOSED AIRPORT  
VAULT

WALL ELEVATIONS

MAY 13, 2008 3:14 PM HINT001214  
I:\AIRPORTS\SAVANNA\07A0144\CAD\SHEETS\E-201.DWG - Layout1

MAY 13, 2008 3:15 PM HINT001214  
 I:\AIRPORTS\SAVANNA\07A0144\CAD\SHEETS\E-602.DWG - Work

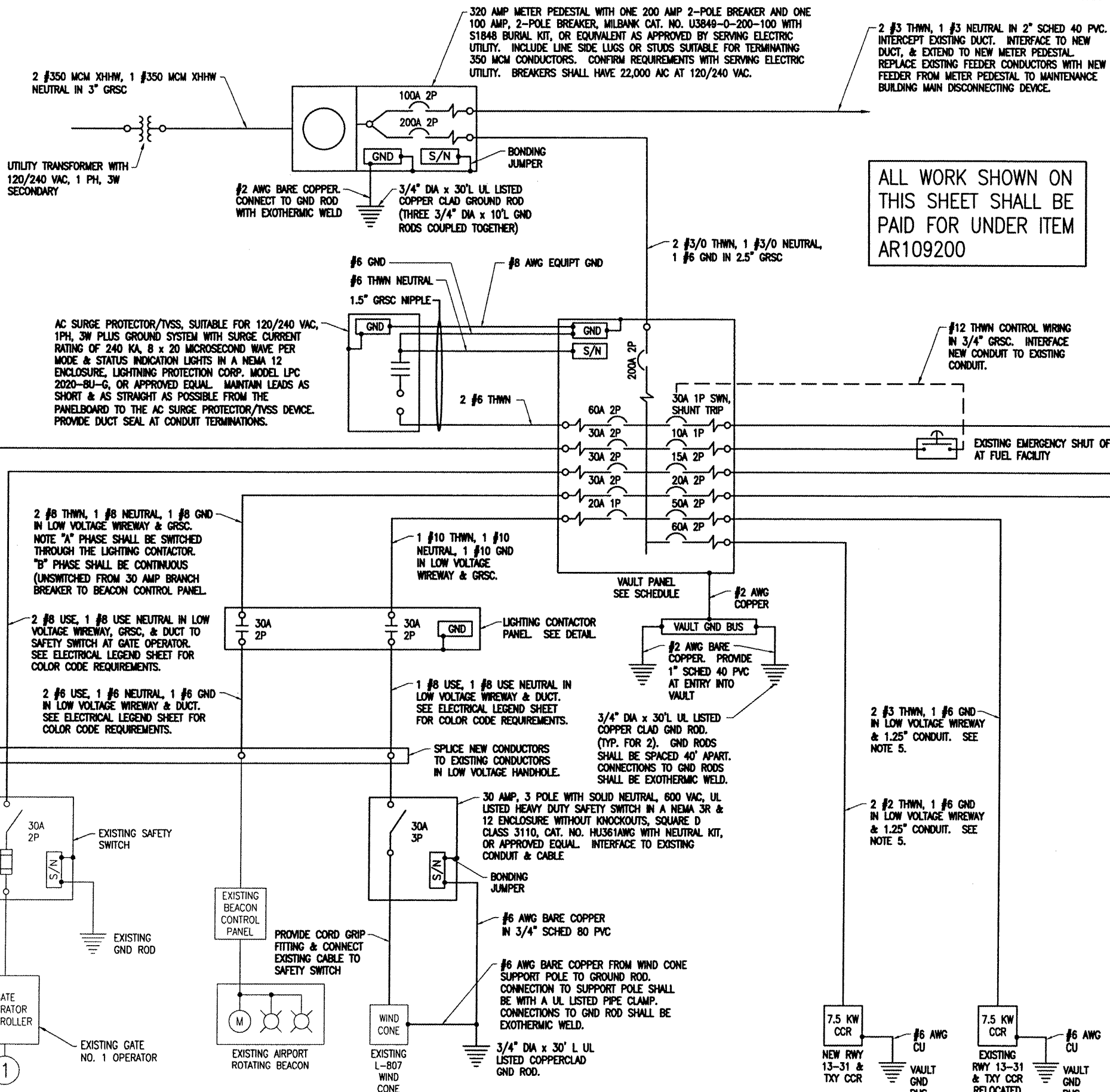

ALL WORK SHOWN ON THIS SHEET SHALL BE PAID FOR UNDER ITEM AR109200

NOTES

1. ALL VAULT WORK AND/OR POWER OUTAGES SHALL BE COORDINATED WITH THE AIRPORT MANAGER. COORDINATE ELECTRIC SERVICE WORK WITH THE SERVING ELECTRIC UTILITY COMPANY, AND THE AIRPORT MANAGER.
2. ALL ELECTRICAL EQUIPMENT SHALL BE INSTALLED IN CONFORMANCE WITH NFPA 70-NATIONAL ELECTRIC CODE (NEC) MOST CURRENT ISSUE IN FORCE, THE RESPECTIVE EQUIPMENT MANUFACTURER'S DIRECTIONS AND ALL OTHER APPLICABLE LOCAL CODES, LAWS, ORDINANCES AND REQUIREMENTS IN FORCE. ANY INSTALLATIONS WHICH VOID THE U.L. LISTING, ETL LISTING, (OR OTHER THIRD PARTY LISTING) AND/OR THE MANUFACTURER'S WARRANTY OF A DEVICE SHALL NOT BE PERMITTED.
3. ALL EQUIPMENT SHOWN IS NEW UNLESS NOTED OTHERWISE, OR LABELED AS "EXISTING".
4. CONTRACTOR SHALL CONFIRM POWER REQUIREMENTS WITH THE ACTUAL NAMEPLATE ON EACH CONSTANT CURRENT REGULATOR (OR OTHER RESPECTIVE EQUIPMENT) AND ADJUST CIRCUIT BREAKER, WIRE SIZES & CONDUIT SIZES TO CONFORM WITH NEC & MANUFACTURER'S RECOMMENDATIONS WHERE APPLICABLE. WIRE SIZES SHOWN ON THE PLANS ARE MINIMUM.
5. BRANCH CIRCUITS TO REGULATORS SHALL BE INSTALLED IN THE RESPECTIVE LOW VOLTAGE WIREWAY/DUCT, WITH GRSC AT TRANSITIONS AND UL LISTED LIQUID TIGHT FLEXIBLE METAL CONDUIT AT FINAL CONNECTIONS TO THE REGULATORS. CONDUITS SHALL BE SIZED IN ACCORDANCE WITH NEC.

TR005

REVISION	DATE	BY

TRI-TOWNSHIP AIRPORT  
 SAVANNA, CARROLL COUNTY  
 ILLINOIS

Proj. No. 07A0144D_0800	Rev. 01/02/08
File Name: E-602.DWG	Drawn: MY
Scale: NONE	Reviewed: CAH
Date: 05/13/08	



CONSTRUCT NEW VAULT  
 PROPOSED VAULT ELECTRICAL ONE-LINE DIAGRAM

VAULT PANEL SCHEDULE			
CKT #	DUTY	SIZE	CKT #
1	TVSS	60A,2P	2
3			4
5	VAULT FAN	15A,1P	6
7	VAULT INTERIOR LIGHTING	15A,1P	8
9	VAULT EXTERIOR LIGHTING	15A,1P	10
11	VAULT RECEPTACLES	20A,1P	12
13	AWOS	30A,2P	14
15			16
17	GATE OPERATOR	30A,2P	18
19			20
21	AIRPORT ROTATING BEACON	30A,2P	22
23			24
25	WIND CONE	20A,1P	26
27	RADIO CONTROL & PHOTOCCELL	10A,1P	28
29	SPARE	20A,1P	30
31	SPARE	20A,1P	32
33	BLANK		34
35			36
37			38
39			40
41			42

225 AMP, 120/240 VAC, 1PHASE, 3 WIRE, 42 CIRCUIT PANELBOARD WITH 200 AMP, 2 POLE MAIN BREAKER WITH 10,000 AIC AT 240 VAC IN A NEMA 1 ENCLOSURE. INCLUDE SEPERATE GROUND BAR KITS. ALL BRANCH BREAKERS SHALL BE BOLT-ON TYPE WITH 10,000 AIC AT 120/240 VAC. PANELBOARD SHALL BE SQUARE D CAT NO. NQ0D42L225CU WITH NQ0DQB MAIN BREAKER KIT & QBL22200 MAIN BREAKER IN A NEMA 1 ENLCOSURE OR APPROVED EQUAL.

- NOTES**
- PANELBOARD BUS SHALL BE COPPER. NEUTRAL BUS SHALL BE COPPER. EQUIPMENT GROUND BARS SHALL BE COPPER.
  - INCLUDE ENGRAVED PHENOLIC LEGEND PLATE LABELED "VAULT PANEL, 120/240 VAC, 1 PHASE, 3 WIRE".
  - FEEDER BREAKER FOR FUEL SYSTEM LOAD CENTER SHALL BE 30 AMP, 1-POLE WITH SWITCHED NEUTRAL & SHUNT TRIP FEATURE.

FUEL FACILITY LOAD CENTER SCHEDULE			
CKT #	DUTY	SIZE	CKT #
1	FUEL FACILITY EQUIPMENT	20A 1P	2
2		SWN	4
3	FUEL FACILITY EQUIPMENT	20A 1P	6
4		SWN	8
5	BLANK		10
6	BLANK		12

100 AMP, 120/240 VAC, 1 PHASE, 3 WIRE, 6 CIRCUIT LOAD CENTER WITH MAIN LUGS, IN A NEMA 1 ENCLOSURE, SQUARE D CLASS 1130, CAT. NO. 00612L100DSCU OR APPROVED EQUAL. INCLUDE EQUIPMENT GROUND BAR KIT. BRANCH BREAKERS SHALL HAVE 10,000 AIC RATING AT 120/240 VAC. LOAD CENTER BUS SHALL BE COPPER.

- NOTES**
- SWN INDICATES BRANCH BREAKER WITH SWITCHED NEUTRAL FEATURE.
  - LOAD CENTER SHALL BE CONNECTED FOR 120 VAC, 1 PHASE, 2-WIRE OPERATION. ONE BUS PHASE WILL NOT BE POWERED.
  - PROVIDE LEGEND PLATE FOR LOAD CENTER LABELED "FUEL SYSTEM PANEL, 120 VAC, 1PH, 2W".

BY	
REVISION	
DATE	

TRI-TOWNSHIP AIRPORT  
SAVANNA, CARROLL COUNTY  
ILLINOIS

IL PROJ.: SFY-3782 A.I.P. PROJ.: 3-17-0091-B14

HE Project No. 07A0144D_0800	01/02/08
Filename E-606.DWG	01/03/08
Scale NONE	02/08/08
Date 05/13/08	
LAYOUT KHL	
DRAWN MV	
REVIEWED CAH	



CONSTRUCT  
NEW VAULT

PANEL SCHEDULE  
& DETAILS

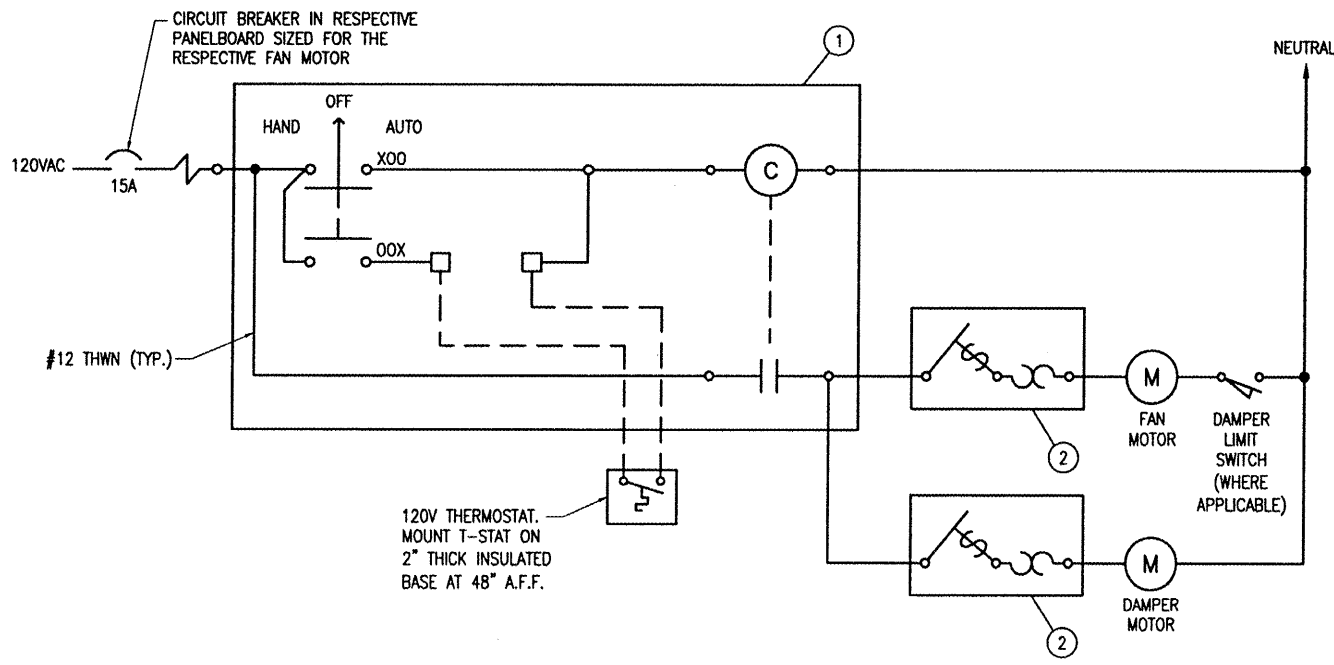

EXHAUST FAN CONTROL SCHEMATIC

**NOTES FOR FAN CONTROL SCHEMATIC**

- GROUND WIRES REQUIRED BUT NOT SHOWN FOR CLARITY.
- ALL WIRING SHALL BE #12 THWN MINIMUM.
- PROVIDE A NEMA 1 ENCLOSURE SIZED AS REQUIRED TO INSTALL THE CONTACTOR, HOA SELECTOR SWITCH & TERMINALS.
- PROVIDE LEGEND PLATE FOR THE CONTACTOR AND FRACTIONAL HP MOTOR STARTER IDENTIFYING THE LOAD SERVED AND THE POWER SOURCE.
- VERIFY MOTOR HORSEPOWERS AND FULL LOAD AMPS WITH THE RESPECTIVE MANUFACTURER. CONTRACTOR SHALL COORDINATE MOTOR CIRCUIT BREAKER, CONTACTOR, FRACTIONAL HP STARTER, OVERLOADS, WIRE SIZES, CONDUIT SIZES, ETC. FOR THE RESPECTIVE EQUIPMENT FURNISHED, PER NEC & MANUFACTURER'S RECOMMENDATIONS. COORDINATE FAN & LOUVER INSTALLATION WITH BUILDING MFR.
- INTAKE LOUVERS SHALL OPEN AND EXHAUST FAN SHALL OPERATE WHEN SPACE TEMP EXCEEDS 85°F (ADJUSTABLE). EXHAUST FAN SHALL OPERATE ONLY WHEN DAMPER HAS PROVED "OPEN". IN MANUAL MODE DAMPER SHALL REMAIN OPEN AND FAN SHALL RUN CONTINUOUSLY.

**LEGEND**

- 120VAC, NEMA SIZE 0 (MINIMUM), 1 POLE, FULL VOLTAGE CONTACTOR IN A NEMA 1 ENCLOSURE, SQUARE D CLASS 8502, TYPE SBG5V02 OR APPROVED EQUAL. INCLUDE H-O-A SELECTOR SWITCH WITH CONTACTOR.
- FRACTIONAL HORSEPOWER MOTOR MANUAL STARTER, SQUARE D MANUAL STARTER WITH HANDLE/GUARD/LOCK OFF, IN NEMA 1 ENCLOSURE CLASS 2510, TYPE FG5 OR APPROVED EQUAL. INCLUDE MELTING ALLOY TYPE THERMAL OVERLOADS SIZED AS REQUIRED TO PROTECT THE RESPECTIVE MOTOR. 120VAC MOTORS SHALL HAVE SINGLE POLE STARTERS.

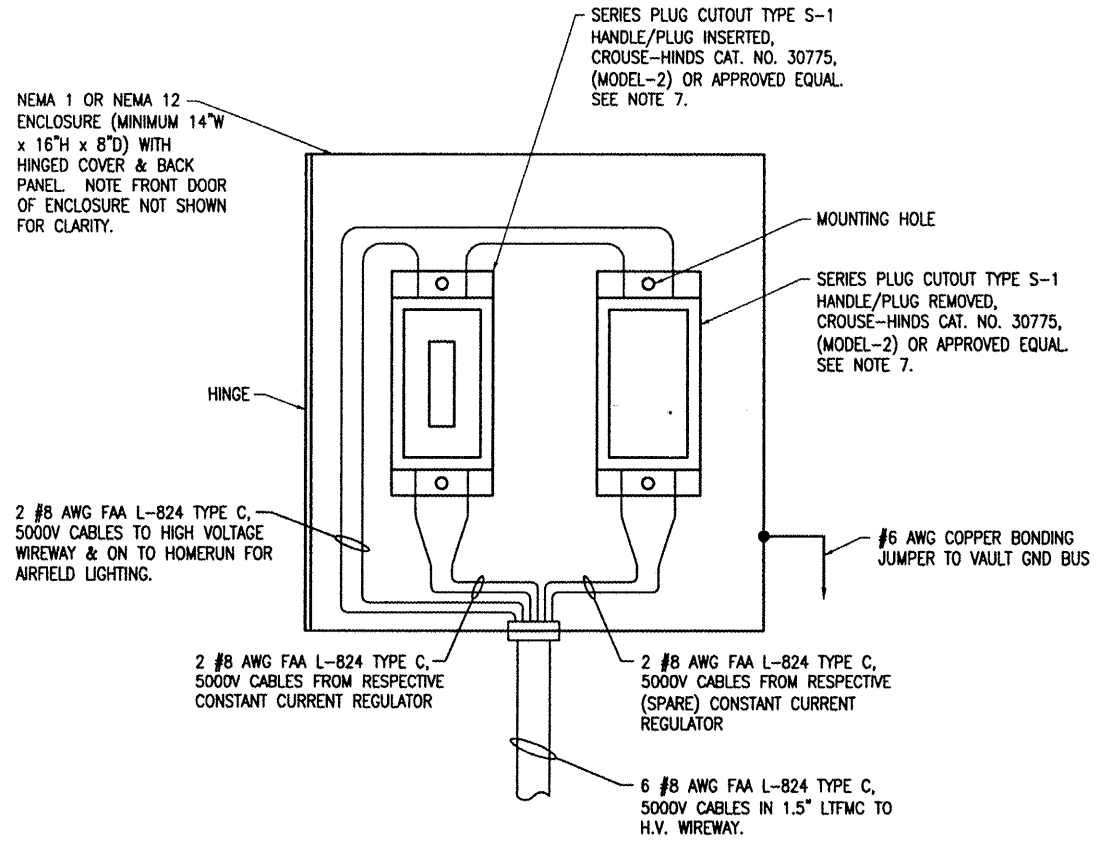

**SERIES PLUG CUTOUT MOUNTING DETAIL  
FOR RUNWAY & TAXIWAY CIRCUIT**

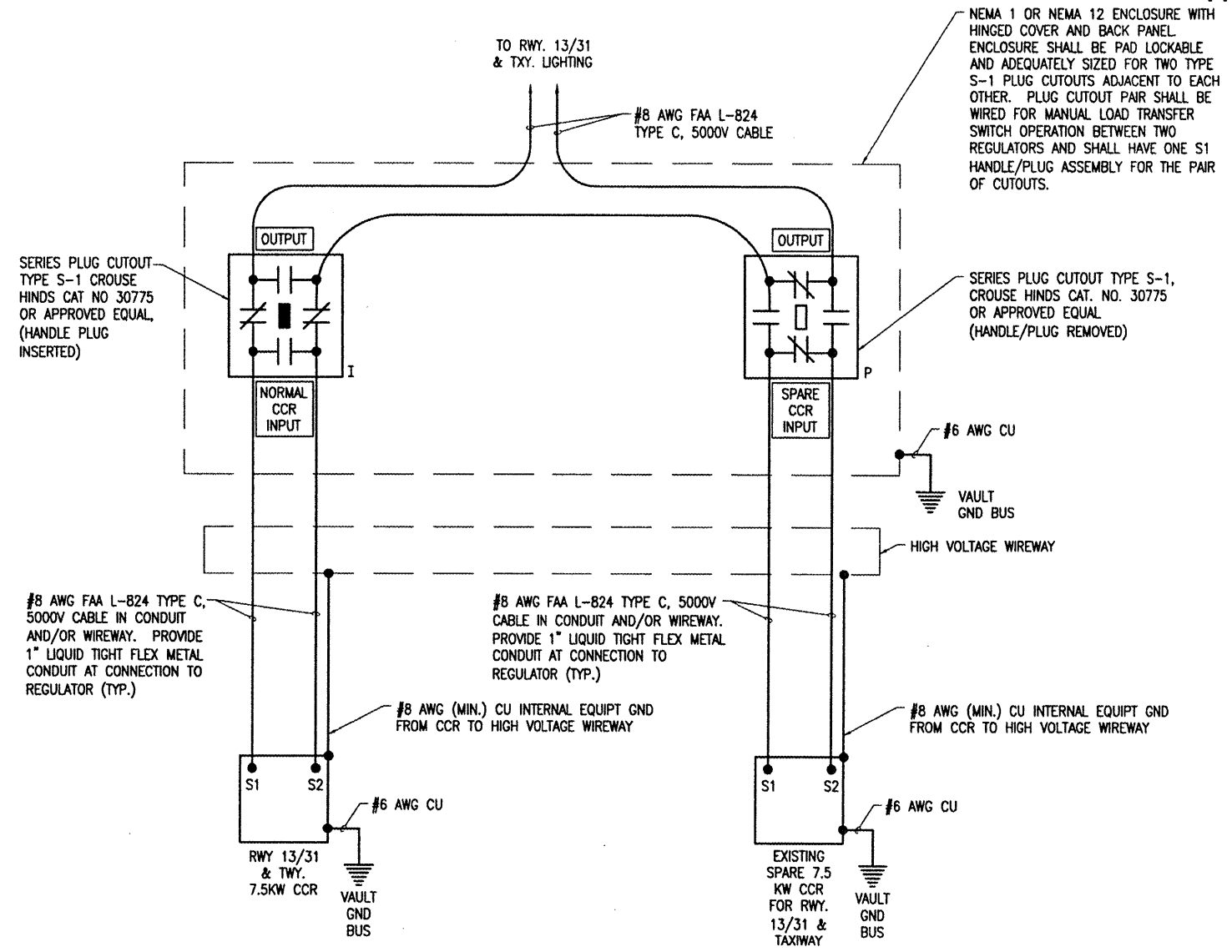

**HIGH VOLTAGE WIRING SCHEMATIC**

**NOTES**

1. PROVIDE PHENOLIC ENGRAVED LEGEND PLATES FOR EACH CONSTANT CURRENT REGULATOR NOTING THE REGULATOR DESIGNATION AND THE RUNWAY OR TAXIWAY SERVED.
2. EACH PLUG CUTOUT CABINET SHALL BE FURNISHED WITH A PHENOLIC ENGRAVED LEGEND PLATE THAT IDENTIFIES THE RESPECTIVE CIRCUIT OR REGULATOR. INCLUDE AN ADDITIONAL LEGEND PLATE LABELED "CAUTION OPERATE CUTOUTS WITH CCR SHUT OFF". FURNISH & INSTALL A WARNING LABEL FOR CUTOUT ENCLOSURE TO WARN PERSONS OF POTENTIAL ARC FLASH HAZARDS, PER THE REQUIREMENTS OF NEC 110.16 "FLASH PROTECTION".
3. PROVIDE PHENOLIC ENGRAVED LEGEND PLATES FOR EACH CUTOUT TO IDENTIFY THE RESPECTIVE CUTOUT INPUT CONNECTION AND THE RESPECTIVE CUTOUT OUTPUT CONNECTION.
4. PROVIDE ADEQUATE WORKING SPACE IN FRONT OF EACH CUTOUT ENCLOSURE TO MEET NEC CLEARANCE REQUIREMENTS.
5. PROVIDE WARNING SIGN ON VAULT DOOR LABELED "DANGER - HIGH VOLTAGE - KEEP OUT" PER THE REQUIREMENTS OF NEC 110.34 (c).
6. LIQUID TIGHT FLEXIBLE METAL CONDUIT AND ASSOCIATED FITTINGS SHALL BE U.L. LISTED TO MEET THE REQUIREMENTS OF NEC 350.6, SUITABLE FOR GROUNDING AND SUNLIGHT RESISTANT. LIQUID TIGHT FLEXIBLE METAL CONDUIT THAT IS USED FOR FLEXIBILITY (INCLUDING CONNECTIONS TO CCR'S & TRANSFORMERS) SHALL REQUIRE AN EXTERNAL BONDING JUMPER OR INTERNAL EQUIPMENT GROUNDING CONDUCTOR PER NEC 350.60. EXTERNAL BONDING JUMPERS USED WITH CCR INSTALLATIONS SHALL BE #6 AWG COPPER (MINIMUM). DO NOT INSTALL LIQUID TIGHT FLEXIBLE METAL CONDUIT THAT IS NOT UL LISTED.
7. CROUSE-HINDS CAT. NO. 30771, (MODEL-3) SERIES PLUG CUTOUTS ARE NOT ACCEPTABLE, BECAUSE THE HANDLE IS NOT REMOVABLE. OTHER CUTOUTS THAT DO NOT FUNCTION THE SAME AS CROUSE-HINDS CAT. NO. 30775 (MODEL-2) ARE NOT ACCEPTABLE.
8. HIGH VOLTAGE & LOW VOLTAGE CIRCUITS SHALL NOT BE INSTALLED IN THE SAME WIREWAY.
9. BOND ALL REGULATORS TO THE RESPECTIVE VAULT GROUND BUS WITH A DEDICATED #6 AWG BONDING JUMPER FOR EACH REGULATOR.

**LEGEND**

- "I" DENOTES PLUG CUTOUT WITH PLUG INSERTED
- "P" DENOTES PLUG CUTOUT WITH PLUG PULLED
- "CCR" DENOTES CONSTANT CURRENT REGULATOR

BY	
REVISION	
DATE	
TRI-TOWNSHIP AIRPORT SAVANNA, CARROLL COUNTY ILLINOIS	
I.P. Project No. 07A01440-0800 Filename E-604.DWG Scale NONE Date 05/13/08	A.I.P. PROJ.: 3-17-0091-B14 I.L. PROJ.: SFY-3782
LAYOUT KNL 01/02/08 DRAWN MV 01/03/08 REVIEWED CAH 02/08/08	
Hanson Professional Services Inc. 1525 South Sixth Street Springfield, Illinois 62703-2886 Offices Nationwide	
CONSTRUCT NEW VAULT	HIGH VOLTAGE WIRING SCHEMATIC
13	
13 of 24 sheets	

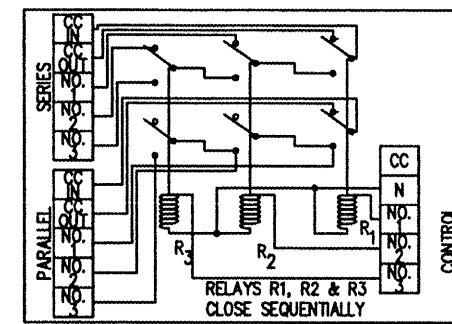
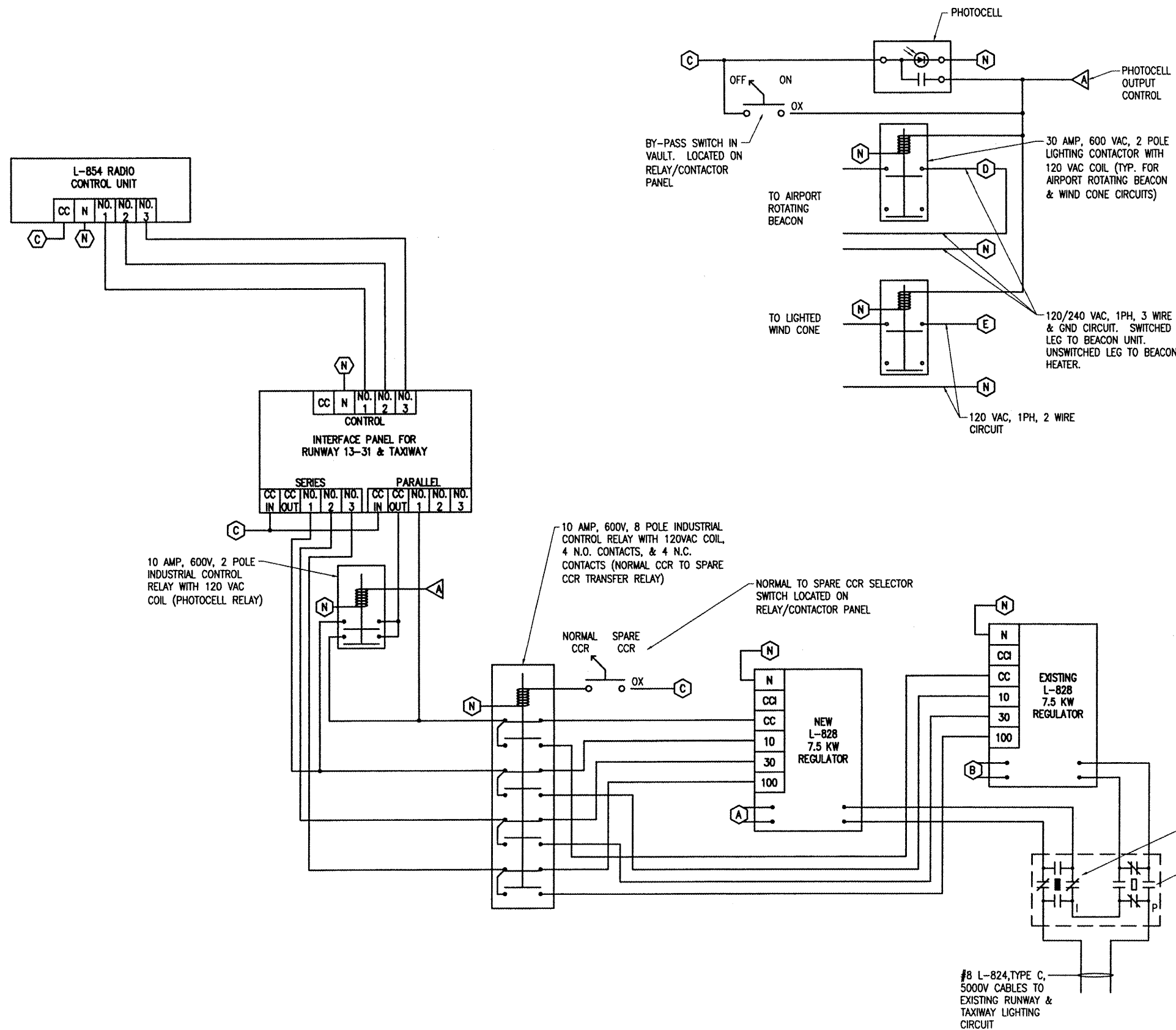

TYP. INTERFACE PANEL DETAIL

NOTES

- ALL ELECTRICAL EQUIPMENT WILL BE WIRED IN ACCORDANCE WITH THE SCHEMATIC WIRING DIAGRAM AND ALL APPLICABLE CODES.
- ALL CONTROL CABLE WILL BE NO. 12 AWG, 600 VOLT CABLE.
- ALL ELECTRICAL EQUIPMENT WILL BE PROPERLY LABELED AND ALL ELECTRICAL CABLES WILL BE TAGGED.
- ALL ELECTRICAL CABLES INSIDE THE VAULT WILL BE IN CONDUIT OR DUCT.
- THE L-854 RADIO OUTPUT SHALL BE ACTIVE 24 HOURS/DAY. PHOTOCELL OR PHOTOCELL BYPASS SWITCH SHALL ACTIVATE 10% BRIGHTNESS. THE RUNWAY/TAXIWAY CIRCUITS WILL BE CONTROLLED BY THE L-854 RADIO CONTROL UNIT IN THE FOLLOWING MANNER:  
 3 CLICKS - 10% BRIGHTNESS  
 5 CLICKS - 30% BRIGHTNESS  
 7 CLICKS - 100% BRIGHTNESS
- ALL CONTROL RELAYS, INTERFACE PANELS, RADIO CONTROL UNIT, PHOTOCELL, CONTROL WIRING, ETC. SHALL BE NEW UNLESS OTHERWISE NOTED.
- EQUIPMENT GROUND WIRES SHALL BE INCLUDED WITH EACH BRANCH CIRCUIT & EACH CONTROL CIRCUIT.
- SEE DETAILS FOR REQUIREMENTS ON RELAY PANEL WITH CONTROL RELAYS & LIGHTING CONTACTORS.
- THE CONTRACTOR WILL HAVE TO CUT A HOLE IN THE PROPOSED VAULT ROOF TO ALLOW THE INSTALLATION OF ONE CONDUIT FOR THE PROPOSED PHOTO-CELL. AFTER INSTALLING THE CONDUIT THE CONTRACTOR WILL SEAL AROUND THE CONDUIT WITH AN APPROVED SEALANT TO INSURE A WATERPROOF BARRIER.

SHEET LEGEND

- (A) VAULT PANEL CKT 14, 16 (RWY 13-31 & TXY CCR)
- (B) VAULT PANEL CKT 10, 12 (SPARE CCR FOR RWY 13-31 & TXY)
- (C) VAULT PANEL CKT 27 (RADIO & PHOTOCELL CONTROL)
- (D) VAULT PANEL CKT 21, 23 (AIRPORT ROTATING BEACON)
- (E) VAULT PANEL CKT 25 (WIND CONE)
- (N) N DESIGNATES NEUTRAL FROM THE RESPECTIVE PANEL THAT POWERS THE DEVICE. FOR CONTROL CIRCUIT INPUTS TO CCR'S N SHALL BE FROM THE RESPECTIVE INTERFACE PANEL CIRCUIT NEUTRAL CONNECTION.

#8 L-824, TYPE C,  
 5000V CABLES TO  
 EXISTING RUNWAY &  
 TAXIWAY LIGHTING  
 CIRCUIT

AIRFIELD LIGHTING SCHEMATIC WIRING DIAGRAM

TR005

BY	
REVISION	
DATE	

TRI-TOWNSHIP AIRPORT  
 SAVANNA, CARROLL COUNTY  
 ILLINOIS

Proj. No. 07A0144D_0800	01/02/08
Drawn E-603.DWG	01/03/08
Scale NONE	02/05/08
Date 05/13/08	
LAYOUT	CAH
DRAWN	MV
REVIEWED	CAH



Hanson Professional Services Inc.  
 1525 South State Street  
 Springfield, Illinois 62703-2888  
 Offices Nationwide

CONSTRUCT  
 NEW VAULT  
 AIRFIELD LIGHTING  
 WIRING SCHEMATIC



NOTES

- 15 AMP & 20 AMP INPUT POWER/BRANCH CIRCUITS SHALL BE #10 AWG COPPER THWN FROM THE RESPECTIVE POWER SOURCE TO THE LIGHTING CONTACTOR/RELAY PANEL. 30 AMP INPUT POWER/BRANCH CIRCUITS SHALL BE #8 AWG COPPER THWN (MIN.) FROM THE RESPECTIVE POWER SOURCE TO THE LIGHTING CONTACTOR/RELAY PANEL.
- INPUT CONTROL CIRCUITS SHALL BE #12 AWG COPPER THWN.
- FOR 120 VAC BRANCH CIRCUITS THE NEUTRAL CONDUCTOR SHALL NOT BE SWITCHED THROUGH THE RELAY CONTACTS. USE TERMINAL BLOCKS TO TRANSITION FROM VAULT BRANCH CIRCUIT WIRING TO FIELD WIRING.
- THE AIRPORT ROTATING BEACON CIRCUIT SHALL HAVE PHASE "A" SWITCHED THROUGH THE LIGHTING CONTACTOR. PHASE "B" SHALL BE UNSWITCHED FROM THE POWER SOURCE TO THE CONTROL PANEL AT THE AIRPORT ROTATING BEACON.
- PROVIDE #10 AWG COPPER BONDING JUMPER FROM PANEL ENCLOSURE FRAME TO ENCLOSURE DOOR.
- PROVIDE 2-POSITION MAINTAINED CONTACT "OFF-ON" SELECTOR SWITCH FOR PHOTOCELL BYPASS CONTROL & MOUNT ON RELAY PANEL ENCLOSURE DOOR. SELECTOR SWITCH SHALL BE SQUARE D CLASS 9001, TYPE KS11FBH13 OR APPROVED EQUAL. INCLUDE LEGEND PLATE LABELED "PHOTOCELL BYPASS".
- PROVIDE 2-POSITION MAINTAINED CONTACT "NORMAL-SPARE" SELECTOR SWITCH FOR CONSTANT CURRENT REGULATOR TRANSFER CONTROL & MOUNT ON RELAY PANEL ENCLOSURE DOOR. SELECTOR SWITCH SHALL BE SQUARE D CLASS 9001, TYPE KS11FBH13 OR APPROVED EQUAL. INCLUDE LEGEND PLATE LABELED "RWY 13-31 CCR TRANSFER" & A LEGEND PLATE TO INDICATE POSITION "NORMAL-SPARE".
- ALL FEEDER AND/OR BRANCH CIRCUIT CONDUCTORS OF THE SAME CIRCUIT (INCLUDING NEUTRAL CONDUCTORS AND EQUIPMENT GROUNDING CONDUCTORS) SHALL BE CONTAINED WITHIN THE SAME RACEWAY, AUXILIARY GUTTER, OR WIREWAY TO COMPLY WITH NEC 300.3(B). FOR VOLTAGE POWERED CIRCUITS TO AIRFIELD DEVICES ROUTE ALL PHASE, NEUTRAL, & EQUIPMENT GROUNDING CONDUCTORS FROM THE VAULT PANELBOARD TO THE RELAY/CONTACTOR PANEL AND THEN TO THE RESPECTIVE AIRFIELD DEVICE.

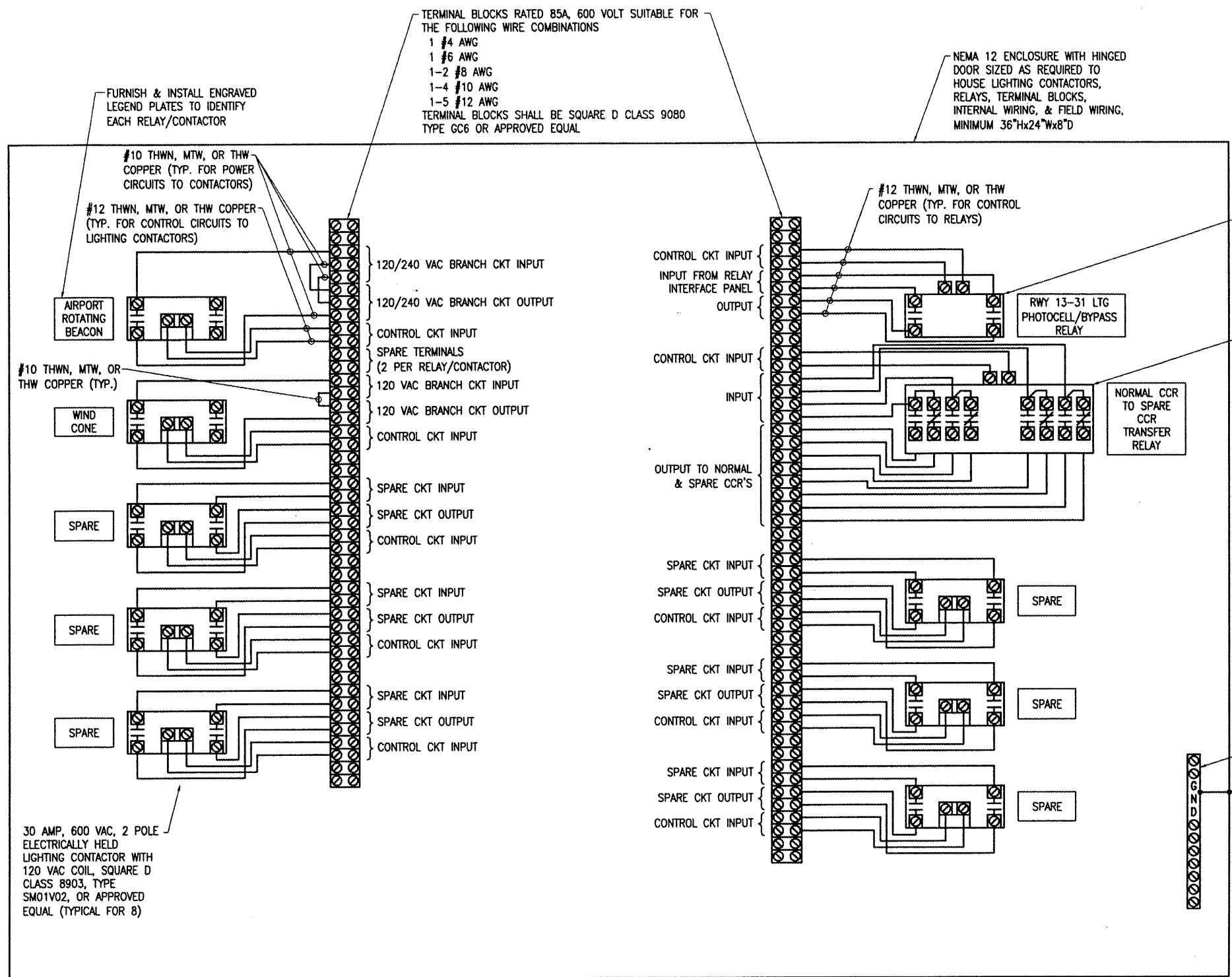

TERMINAL BLOCKS RATED 85A, 600 VOLT SUITABLE FOR THE FOLLOWING WIRE COMBINATIONS  
 1 #4 AWG  
 1 #6 AWG  
 1-2 #8 AWG  
 1-4 #10 AWG  
 1-5 #12 AWG  
 TERMINAL BLOCKS SHALL BE SQUARE D CLASS 9080 TYPE GC6 OR APPROVED EQUAL

NEMA 12 ENCLOSURE WITH HINGED DOOR SIZED AS REQUIRED TO HOUSE LIGHTING CONTACTORS, RELAYS, TERMINAL BLOCKS, INTERNAL WIRING, & FIELD WIRING, MINIMUM 36"Hx24"Wx8"D

FURNISH & INSTALL ENGRAVED LEGEND PLATES TO IDENTIFY EACH RELAY/CONTACTOR

#10 THWN, MTW, OR THW COPPER (TYP. FOR POWER CIRCUITS TO CONTACTORS)

#12 THWN, MTW, OR THW COPPER (TYP. FOR CONTROL CIRCUITS TO LIGHTING CONTACTORS)

#12 THWN, MTW, OR THW COPPER (TYP. FOR CONTROL CIRCUITS TO RELAYS)

10 AMP, 600 VAC, 2 POLE NEMA TYPE, INDUSTRIAL CONTROL RELAY WITH 120 VAC COIL, SQUARE D CLASS 8501, TYPE X020V02 OR APPROVED EQUAL.

10 AMP, 600 VAC, 8 POLE (4 N.O. & 4 N.C.) NEMA TYPE, INDUSTRIAL CONTROL RELAY WITH 120 VAC COIL, SQUARE D CLASS 8501, TYPE X080V02 OR APPROVED EQUAL.

EQUIPMENT GROUND BAR ADEQUATELY SIZED FOR ALL GROUND WIRES TO AND FROM RELAY CONTACTOR PANEL ILSCO CAT. NO. D167-14, OR EQUAL. INSTALL ONE EQUAL GROUND WIRE PER TERMINAL.

30 AMP, 600 VAC, 2 POLE ELECTRICALLY HELD LIGHTING CONTACTOR WITH 120 VAC COIL, SQUARE D CLASS 8903, TYPE SM01V02, OR APPROVED EQUAL (TYPICAL FOR 8)

DATE	REVISION	BY

TRI-TOWNSHIP AIRPORT  
 SAVANNA, CARROLL COUNTY  
 ILLINOIS

IL PROJ.: SFY-3782 A.I.P. PROJ.: J-17-0091-B14

HEL Project No. 07A01440_0800	FILENAME E-605.DWG	Scale NONE	Date 05/13/08
LAYOUT	KNL	01/02/08	01/03/08
DRAWN	WV	01/03/08	02/08/08
REVIEWED	CAH	02/08/08	

**HANSON**  
 Hanson Professional Services Inc.  
 1525 South Sixth Street  
 Springfield, Illinois 62703-2886  
 Chicago Nationwide

CONSTRUCT  
 NEW VAULT  
 RELAY/CONTACTOR  
 PANEL DETAIL

VAULT LEGEND PLATE SCHEDULE	
DEVICE	LABEL
SERVICE BREAKER FOR VAULT	SERVICE DISCONNECT FOR VAULT 120/240VAC, 1PH, 3W
SERVICE BREAKER FOR MAINTENANCE BUILDING	SERVICE DISCONNECT FOR MAINT. BLDG.
VAULT PANELBOARD	VAULT PANEL 120/240 VAC, 1 PH, 3W FED FROM SERVICE DISCONNECT
MAIN BREAKER IN VAULT PANEL	MAIN DISCONNECT
RUNWAY 13-31 & TAXIWAY CCR	RUNWAY 13-31 & TAXIWAY
SPARE RUNWAY 13-31 & TAXIWAY CCR	SPARE FOR RUNWAY 13-31 & TAXIWAY
CUTOUT ENCLOSURE FOR RUNWAY 13-31 & TAXIWAY	RUNWAY 13-31 & TAXIWAY CUTOUTS
CUTOUT ENCLOSURE FOR RUNWAY 13-31 & TAXIWAY	CAUTION OPERATE CUTOUTS WITH CCR SHUT OFF
NORMAL CUTOUT INPUT SIDE CONNECTION	NORMAL CCR INPUT
SPARE CUTOUT INPUT SIDE CONNECTION	SPARE CCR INPUT
EACH CUTOUT OUTPUT SIDE CONNECTION	OUTPUT
RADIO INTERFACE PANEL FOR RUNWAY 13-31 & TAXIWAY	RUNWAY 13-31 & TAXIWAY
RELAY/CONTACTOR PANEL	CONTACTOR PANEL FOR AIRFIELD LIGHTING EQUIPMENT
CONTACTOR FOR EXHAUST FAN	EXHAUST FAN CONTACTOR
LOW VOLTAGE WIREWAY (PROVIDE 4 LEGEND PLATES 1/2" HIGH BLACK LETTERS WHITE BACKGROUND)	LOW VOLTAGE
HIGH VOLTAGE WIREWAY (PROVIDE 4 LEGEND PLATES 1/2" HIGH BLACK LETTERS WHITE BACKGROUND)	HIGH VOLTAGE
VAULT GROUND BUS (PROVIDE 4 LEGEND PLATES 1/2" HIGH WHITE LETTERS GREEN BACKGROUND)	VAULT GROUND BUS

NOTE: LEGEND PLATES SHALL BE WEATHERPROOF ENGRAVED PLASTIC OR PHENOLIC MATERIAL, 1/4" HIGH BLACK LETTERS ON A WHITE BACKGROUND UNLESS NOTED OTHERWISE. SECURE WITH WEATHERPROOF ADHESIVE AND MACHINE SCREWS. FURNISH ADDITIONAL LEGEND PLATES WHERE REQUIRED BY CODE, FOR ADDITIONAL EQUIPMENT, AS DETAILED HEREIN ON THE PLANS, AND AS NOTED IN THE SPECIAL PROVISION SPECIFICATIONS.

FURNISH & INSTALL A WEATHERPROOF WARNING LABEL FOR EACH SAFETY SWITCH, PANELBOARD, LOAD CENTER, CUTOUT, & CONTROL PANEL TO WARN PERSONS OF POTENTIAL ELECTRIC ARC FLASH HAZARDS, PER THE REQUIREMENTS OF NEC 110.16 "FLASH PROTECTION". LABELS SHALL BE HAZARD COMMUNICATION SYSTEMS, LLC (190 OLD MILFORD RD., BOX 1174, MILFORD, PA 18337, PHONE: 1-877-748-0244) PART NO. H6010-9VWHBJ OR APPROVED EQUAL.

- DIRECTIONS TO TRANSFER RUNWAY 13-31 & TAXIWAY LIGHTING FROM NORMAL CCR TO SPARE CCR.
1. SHUT OFF INPUT POWER (CIRCUIT BREAKER) TO BOTH RWY 13-31/TXY CCR'S & TURN CCR SELECTOR SWITCHES TO OFF.
  2. PULL CUTOUT HANDLE FROM NORMAL CCR UNIT & INSERT INTO SPARE CCR CUTOUT.
  3. TURN ON INPUT POWER (CIRCUIT BREAKER) TO SPARE RWY 13-31/TXY CCR.
  4. GO TO CONTACTOR PANEL & TURN "RWY 13-31 CCR TRANSFER" SELECTOR SWITCH FROM "NORMAL" TO "SPARE" POSITION.
  5. TURN SELECTOR SWITCH ON SPARE CCR TO "REMOTE" POSITION.

PROVIDE PLACARD OR LEGEND PLATE FOR RUNWAY CONSTANT CURRENT REGULATOR PAIR AS NOTED ABOVE: LETTERING TO BE MIN. 1/4" HIGH, BLACK ON WHITE BACKGROUND. LOCATE PLACARD ABOVE CUTOUT ENCLOSURE.

PLACARD DETAIL

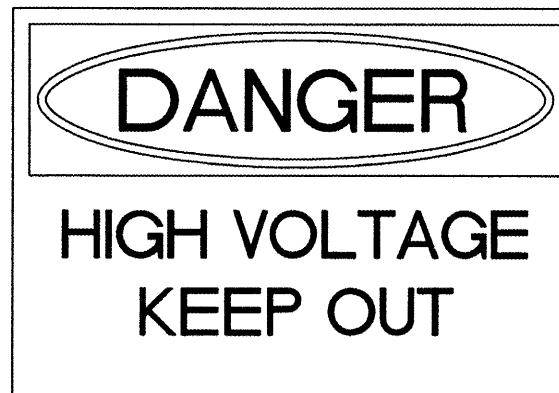

PROVIDE WARNING SIGN ON VAULT EXTERIOR DOORS LABELED "DANGER - HIGH VOLTAGE - KEEP OUT" PER THE REQUIREMENTS OF NEC 110.34 (C).

DATE	REVISION	BY
TRI-TOWNSHIP AIRPORT SAVANNA, CARROLL COUNTY ILLINOIS		
I.L. PROJ.: SFY-3782      A.I.P. PROJ.: 3-17-0091-B14		
I&E Project No.: 07A0144D_0800 Filename: E-504.DWG Scale: NONE Date: 05/13/08	LAYOUT: KNL 01/02/08 DRAWN: MY 01/03/08 REVIEWED: CAH 02/08/08	Hanon Professional Services Inc. 1525 South Sixth Street Springfield, Illinois 62703-2886 Offices Nationwide
CONSTRUCT NEW VAULT	LEGEND PLATE SCHEDULE	16
16 of 24 sheets		

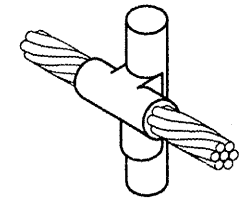

CABLE TO GROUND ROD

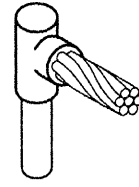

CABLE TO GROUND ROD

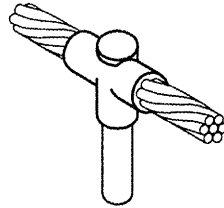

CABLE TO GROUND ROD

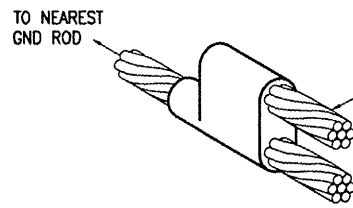

CABLE TO CABLE  
HORIZONTAL PARALLEL TAP

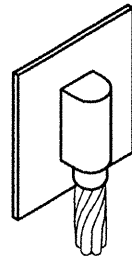

CABLE TO SURFACE

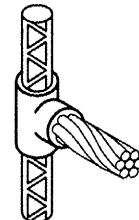

CABLE TO REBAR

DETAIL NOTES

- ALL BELOW GRADE CONNECTIONS TO GROUND RODS & GROUND RING CONDUCTORS SHALL BE EXOTHERMIC WELD TYPE CONNECTIONS. EXOTHERMIC WELDS SHALL BE CADWELDED AS MANUFACTURED BY ERICO PRODUCTS, SOLON, OHIO, ULTRAWELD AS MANUFACTURED BY HARGER LIGHTNING PROTECTION & GROUNDING EQUIPMENT, GRAYSLAKE, IL, OR THERMOWELD AS MANUFACTURED BY CONTINENTAL INDUSTRIES, TULSA, OKLAHOMA. VERIFY PROPER SIZES, MOLDS, TYPES, AND REQUIREMENTS FOR THE RESPECTIVE APPLICATION WITH THE MANUFACTURER, AND INSTALL PER THEIR DIRECTIONS.
- FOR APPLICATIONS TO GALVANIZED STEEL OR PAINTED STEEL, REMOVE GALVANIZING AND/OR PAINT & CLEAN THE SURFACE TO EXPOSE BARE STEEL BEFORE MAKING EXOTHERMIC WELD CONNECTION.
- INDIVIDUAL GROUNDING ELECTRODE CONDUCTORS SHALL NOT BE INSTALLED IN METAL CONDUIT. INSTALL GROUNDING ELECTRODE CONDUCTORS IN SCHED 40 PVC CONDUIT AS REQUIRED IN FOUNDATIONS, FOR PROTECTION, WHERE ENTERING ENCLOSURES, ETC. WHERE PLASTIC CONDUIT IS USED FOR INDIVIDUAL GROUND WIRES, DO NOT COMPLETELY ENCIRCLE THE CONDUIT WITH FERROUS AND/OR MAGNETIC MATERIALS. WHERE METAL CLAMPS ARE INSTALLED USE NYLON BOLTS, NUTS, WASHERS, & SPACERS TO INTERRUPT A COMPLETE METALLIC PATH FROM ENCIRCLING THE CONDUIT.

EXOTHERMIC WELD DETAILS

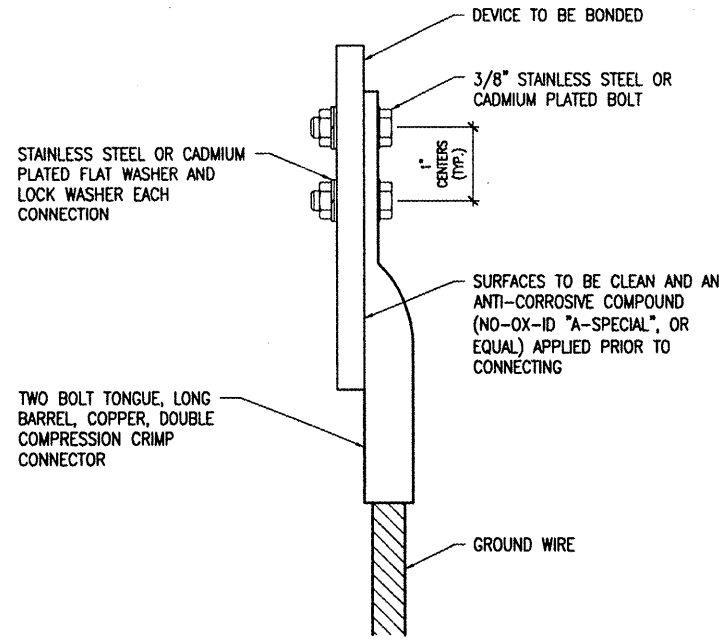

2 HOLE LONG BARREL COMPRESSION LUG TABLE			
WIRE SIZE	BURNDY CAT. NO.	THOMAS & BETTS CAT. NO.	PENN-UNION CAT. NO.
#6 AWG STRANDED	YA6C-2TC3B	256-30695-1158	BBLU-6D-2TC3B
#4 AWG STRANDED	YA4C-2TC3B	256-30695-1159	BBLU-4D-2TC3B
#2 AWG STRANDED	YA2C-2TC3B	256-30695-1160	BBLU-2D-2TC3B
#2 AWG SOLID	YA3C-2TC3B	256-30695-1160	BBLU-3D-2TC3B
#1/0 AWG STRANDED	YA25-2TC3B	256-30695-1162	BBLU-1/0D-2TC3B
#2/0 AWG STRANDED	YA26-2TC3B	256-30695-1116	BBLU-2/0D-2TC3B
#3/0 AWG STRANDED	YA27-2TC3B	548168E	BBLU-3/0D-2TC3B
#4/0 AWG STRANDED	YA28-2TC3B	256-30695-1117	BBLU-4/0D-2TC3B

NOTES

- ALL CONNECTIONS TO GROUND BUS BAR SHALL BE WITH 2 HOLE TONGUE LONG BARREL COMPRESSION LUGS BOLTED TO THE BUS BAR.
- GROUND WIRE CONNECTIONS TO EQUIPMENT SHALL BE WITH 2 HOLE TONGUE LONG BARREL COMPRESSION LUGS BOLTED TO THE DEVICE OR WITH THE RESPECTIVE EQUIP MANUFACTURER'S LUG OR TERMINAL WHERE APPLICABLE.
- GROUNDING ELECTRODE CONDUCTORS, BONDING JUMPERS, & INDIVIDUAL GROUND WIRES SHALL NOT BE INSTALLED IN METAL CONDUIT. WHERE PLASTIC CONDUIT IS USED FOR INDIVIDUAL GROUND WIRES, DO NOT COMPLETELY ENCIRCLE THE CONDUIT WITH FERROUS AND/OR MAGNETIC MATERIALS. WHERE METAL CLAMPS ARE INSTALLED USE NYLON BOLTS, NUTS, WASHERS, & SPACERS TO INTERRUPT A COMPLETE METALLIC APTH FROM ENCIRCLING THE CONDUIT.
- ALL CONNECTIONS SHALL BE COATED WITH A CORROSION PREVENTATIVE COMPOUND (SANCHEM INC. NO-OX-ID "A-SPECIAL", BURNDY PENETROX E, OR EQUAL) BEFORE JOINING. ALL COPPER BUS BARS SHALL BE CLEANED PRIOR TO MAKING CONNECTIONS TO REMOVE SURFACE OXIDATION. CLEAN SURFACES, OF RESPECTIVE DEVICES TO BE BONDED, TO BARE METAL, PER NEC 250-12.

GROUNDING LUG CONNECTION DETAIL

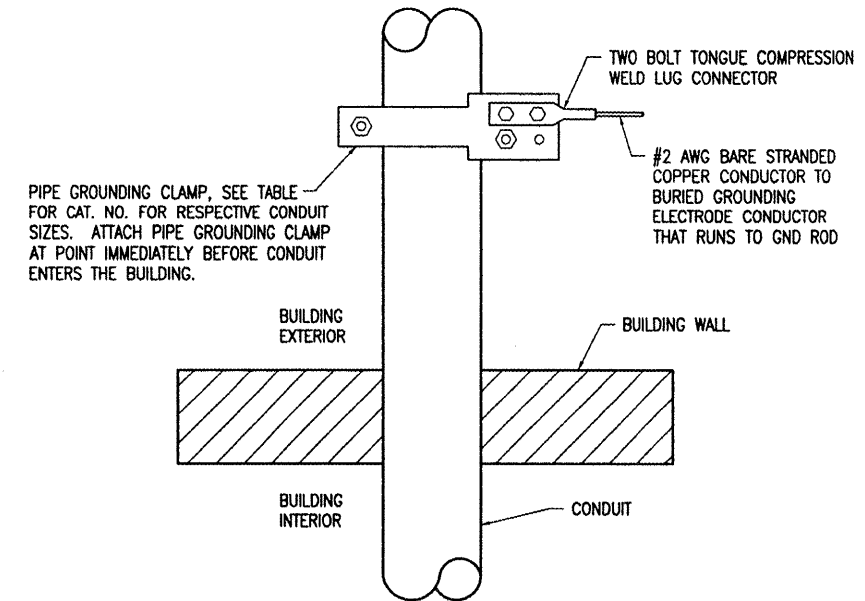

PIPE GROUNDING CLAMP TABLE	
BURNDY CAT. NO.	CONDUIT SIZE
GAR3902TC	1/2" - 1"
GAR3903TC	1 1/4" - 2"
GAR3904TC	2 1/2" - 3 1/2"
GAR3905TC	4" - 5"
GAR3906TC	6"
GAR3907TC	8"

NOTES

- EXTERIOR CONDUIT GROUNDING IS REQUIRED FOR THE PHOTOCELL CONDUIT, RADIO ANTENNA CONDUIT, & OTHER CONDUITS EXTENDING TO THE ROOF LEVEL.
- CONNECTIONS TO BURIED GROUNDING ELECTRODE CONDUCTOR SHALL BE EXOTHERMIC WELD.

EXTERIOR CONDUIT GROUNDING DETAIL

BY	REVISION	DATE

TRI-TOWNSHIP AIRPORT  
SAVANNA, CARROLL COUNTY  
ILLINOIS

IL PROJ.: SFY-3782 A.I.P. PROJ.: 3-17-0091-B14

IBD Project No. 07A01440_0800	Client E-503.DWG	Scale NONE	Date 05/13/08
LAYOUT	KNL	01/02/08	01/02/08
DRAWN	MDR	01/02/08	01/02/08
REVIEWED	CAH	02/08/08	02/08/08



CONSTRUCT  
NEW VAULT

GROUNDING DETAILS

**GROUNDING NOTES**

- THE CONTRACTOR SHALL FURNISH AND INSTALL ALL GROUNDING AS MAY BE NECESSARY OR REQUIRED TO MAKE A COMPLETE GROUNDING SYSTEM AS REQUIRED BY THE LATEST NATIONAL ELECTRICAL CODE (NFPA 70) IN FORCE AND FAA-STD-019e (LIGHTNING AND SURGE PROTECTION, GROUNDING, BONDING, AND SHIELDING REQUIREMENTS FOR FACILITIES AND ELECTRONIC EQUIPMENT). THE RELIABILITY OF THE GROUNDING SYSTEM IS DEPENDENT ON CAREFUL, PROPER INSTALLATION AND CHOICE OF MATERIALS. IMPROPER PREPARATION OF SURFACES TO BE JOINED TO MAKE AN ELECTRICAL PATH, LOOSE JOINTS OR CORROSION CAN INTRODUCE IMPEDANCE THAT WILL SERIOUSLY IMPAIR THE ABILITY OF THE GROUND PATH TO PROTECT PERSONNEL AND EQUIPMENT AND TO ABSORB TRANSIENTS THAT CAN CAUSE NOISE IN COMMUNICATIONS CIRCUITS. THE FOLLOWING FUNCTIONS ARE PARTICULARLY IMPORTANT TO ENSURE A RELIABLE GROUND SYSTEM:
- FURNISH AND INSTALL GROUND RODS AS DETAILED HEREIN. GROUND RODS SHALL BE 3/4-IN. DIAMETER BY 30-FT LONG, UL-LISTED, COPPER CLAD WITH 10-MIL MINIMUM COPPER COATING (THREE 3/4" DIA X 10' L RODS COUPLED TOGETHER). GROUND RODS SHALL IN NO CASE BE SPACED LESS THAN ONE ROD LENGTH APART. ALL CONNECTIONS TO GROUND RODS AND GROUNDING ELECTRODE CONDUCTORS LOCATED BELOW GRADE SHALL BE MADE WITH EXOTHERMIC WELD TYPE CONNECTORS, CADWELD BY ERICO PRODUCTS, INC., SOLON, OHIO, (PHONE 1-800-248-9353), THERMOWELD BY CONTINENTAL INDUSTRIES, INC., TULSA, OKLAHOMA (PHONE 918-663-1440) OR ULTRAWELD BY HARGER, GRAYSLAKE, ILLINOIS (PHONE 1-800-842-7437). EXOTHERMIC WELD CONNECTIONS SHALL BE INSTALLED IN CONFORMANCE WITH THE RESPECTIVE MANUFACTURER'S DIRECTIONS USING MOLDS AS REQUIRED FOR EACH RESPECTIVE APPLICATION. BOLTED CONNECTIONS WILL NOT BE PERMITTED AT GROUND RODS OR AT BURIED GROUNDING ELECTRODE CONDUCTORS.
- CONTRACTOR SHALL TEST THE MADE ELECTRODE GROUND ROD/GROUND FIELD, GROUND RING WITH AN INSTRUMENT SPECIFICALLY DESIGNED FOR TESTING GROUND FIELD SYSTEMS. IF GROUND RESISTANCE EXCEEDS 10 OHMS, CONTACT THE RESIDENT ENGINEER FOR FURTHER DIRECTION. COPIES OF GROUND FIELD TEST RESULTS SHALL BE FURNISHED TO THE RESIDENT ENGINEER, UPON REQUEST, FOR REVIEW AND RECORD PURPOSES.
- ALL PRODUCTS ASSOCIATED WITH THE GROUNDING SYSTEM SHALL BE UL-LISTED AND LABELED.
- ALL BOLTED OR MECHANICAL CONNECTIONS SHALL BE COATED WITH A CORROSION PREVENTATIVE COMPOUND BEFORE JOINING, SANCHEM INC. "NO-OX-ID "A-SPECIAL" COMPOUND, OR EQUAL.
- METALLIC SURFACES TO BE JOINED SHALL BE PREPARED BY THE REMOVAL OF ALL NON-CONDUCTIVE MATERIAL, PER 2005 NATIONAL ELECTRICAL CODE ARTICLE 250-12. ALL COPPER BUS BARS MUST BE CLEANED PRIOR TO MAKING CONNECTIONS TO REMOVE SURFACE OXIDATION.
- METALLIC RACEWAY FITTINGS SHALL BE MADE UP TIGHT TO PROVIDE A PERMANENT LOW IMPEDANCE PATH FOR ALL CIRCUITS. METAL CONDUIT TERMINATIONS IN ENCLOSURES SHALL BE BONDED TO THE ENCLOSURE WITH UL-LISTED FITTINGS SUITABLE FOR GROUNDING. PROVIDE GROUNDING BUSHINGS WITH BONDING JUMPERS FOR ALL METAL CONDUITS ENTERING SERVICE EQUIPMENT (METER BASE, CT CABINET, MAIN SERVICE BREAKER ENCLOSURE, ETC.). PROVIDE GROUNDING BUSHINGS WITH BONDING JUMPERS FOR ALL METAL CONDUITS ENTERING AN ENCLOSURE THROUGH CONCENTRIC OR ECCENTRIC KNOCKOUTS THAT ARE PUNCHED OR OTHERWISE FORMED SO AS TO IMPAIR THE ELECTRICAL CONNECTION TO GROUND. STANDARD LOCKNUTS OR BUSHINGS SHALL NOT BE THE SOLE MEANS FOR BONDING WHERE A CONDUIT ENTERS AN ENCLOSURE THROUGH A CONCENTRIC OR ECCENTRIC KNOCKOUT
- ALL CONNECTIONS, LOCATED ABOVE GRADE, BETWEEN THE DIFFERENT TYPES OF GROUNDING CONDUCTORS SHALL BE MADE USING UL-LISTED DOUBLE COMPRESSION CRIMP TYPE CONNECTORS OR UL-LISTED BOLTED GROUND CONNECTORS. FOR GROUND CONNECTIONS TO ENCLOSURES, CASES AND FRAMES OF ELECTRICAL EQUIPMENT NOT SUPPLIED WITH GROUND LUGS THE CONTRACTOR SHALL DRILL REQUIRED HOLES FOR MOUNTING A BOLTED GROUND CONNECTOR. ALL BOLTED GROUND CONNECTORS SHALL BE BURNDY, THOMAS AND BETTS, OR EQUAL. TIGHTEN CONNECTIONS TO COMPLY WITH TIGHTENING TORQUES IN UL STANDARD 486A TO ASSURE PERMANENT AND EFFECTIVE GROUNDING.
- ALL METAL EQUIPMENT ENCLOSURES, CONDUITS, CABINETS, BOXES, RECEPTACLES, MOTORS, ETC. SHALL BE BONDED TO THE RESPECTIVE GROUNDING SYSTEM.
- PROVIDE ALL BOXES FOR PROPOSED OUTLETS, SWITCHES, CIRCUIT BREAKERS, ETC. WITH GROUNDING SCREWS. PROVIDE ALL PANELBOARD, SWITCHGEAR, ETC., ENCLOSURES WITH GROUNDING BARS WITH INDIVIDUAL SCREWS, LUGS, CLAMPS, ETC., FOR EACH OF THE GROUNDING CONDUCTORS THAT ENTER THEIR RESPECTIVE ENCLOSURES.
- EACH FEEDER CIRCUIT AND/OR BRANCH CIRCUIT SHALL INCLUDE AN EQUIPMENT GROUND WIRE. METAL RACEWAY OR CONDUIT SHALL NOT MEET THIS REQUIREMENT. THE EQUIPMENT GROUND WIRE FROM EQUIPMENT SHALL NOT BE SMALLER THAN ALLOWED BY 2005 NEC TABLE 250-122 "MINIMUM SIZE CONDUCTORS OR GROUNDING RACEWAY AND EQUIPMENT." WHEN CONDUCTORS ARE ADJUSTED IN SIZE TO COMPENSATE FOR VOLTAGE DROP, EQUIPMENT-GROUNDING CONDUCTORS SHALL BE ADJUSTED PROPORTIONATELY ACCORDING TO CIRCULAR MIL AREA. ALL EQUIPMENT GROUND WIRES SHALL BE COPPER, EITHER BARE OR INSULATED GREEN IN COLOR. WHERE THE EQUIPMENT GROUNDING CONDUCTORS ARE INSULATED, THEY SHALL BE IDENTIFIED BY THE COLOR GREEN, AND SHALL BE THE SAME INSULATION TYPE AS THE PHASE CONDUCTORS.

- ALL EXTERIOR METAL CONDUIT, WHERE NOT ELECTRICALLY CONTINUOUS BECAUSE OF MANHOLES, HANDHOLES, NON-METALLIC JUNCTION BOXES, ETC., SHALL BE BONDED TO ALL OTHER METAL CONDUIT IN THE RESPECTIVE DUCT RUN, AND AT EACH END, WITH A COPPER-BONDING JUMPER SIZED IN CONFORMANCE WITH 2005 NEC 250-102. WHERE METAL CONDUITS TERMINATE IN AN ENCLOSURE (SUCH AS A MOTOR CONTROL CENTER, SWITCHBOARD, ETC) WHERE THERE IS NOT ELECTRICAL CONTINUITY WITH THE CONDUIT AND THE RESPECTIVE ENCLOSURE, PROVIDE A BONDING JUMPER FROM THE RESPECTIVE ENCLOSURE GROUND BUS TO THE CONDUIT SIZED PER 2005 NEC 250-102.
- IT IS THE INTENT OF THIS SPECIFICATION THAT ALL MOTOR FRAMES, PUMP BASES ELECTRICAL EQUIPMENT ENCLOSURES, PANEL HOUSINGS, CONDUITS, BOXES, ETC. HAVE A CONTINUOUS COPPER WIRE GROUND CONNECTION AND SHALL BE POSITIVELY BONDED TO THE RESPECTIVE GROUNDING SYSTEM. CONDUIT CONNECTORS WILL NOT BE CONSIDERED AS ADEQUATE GROUNDING.
- PROVIDE A POSITIVE GROUND BOND FOR ALL OUTLET BOXES, ELECTRICAL EQUIPMENT ENCLOSURES, GROUNDING RECEPTACLES, TOGGLE SWITCHES, ETC. INSTALL A GROUNDING CONDUCTOR IN ALL WIRE AND CABLE RACEWAYS. GROUND CONDUCTOR TO HAVE 600-VOLT INSULATION AND BE IDENTIFIED BY A CONTINUOUS GREEN COLOR COATING. THEY SHALL BE USED SOLELY FOR GROUNDING PURPOSES AND BE ENTIRELY SEPARATE FROM WHITE GROUND NEUTRAL CONDUCTOR, EXCEPT AT SUPPLY SIDE OF SERVICE DISCONNECTING MEANS, WHERE GROUNDING AND NEUTRAL SYSTEMS ARE TO BE CONNECTED TO SERVICE GROUND.
- EACH AND ALL GROUND CASED AND METAL PARTS ASSOCIATED WITH ELECTRICAL EQUIPMENT SHALL BE TESTED FOR CONTINUITY OF CONNECTION WITH GROUND BUS SYSTEM BY CONTRACTOR IN PRESENCE OF OWNER'S REPRESENTATIVE.
- ALL CONNECTIONS BETWEEN THE DIFFERENT TYPES OF GROUNDING CONDUCTORS ABOVE GRADE SHALL BE MADE USING BOLTED GROUND CONNECTORS. GROUND LUGS SHALL BE PROVIDED IN ALL ENCLOSURES AND WIRING TERMINATION JUNCTION BOXES. EQUIPMENT GROUNDS AND GROUNDING CONDUCTOR SHALL BE CONNECTED TO THESE GROUND LUGS. FOR GROUND CONNECTIONS TO ENCLOSURES, CASES AND FRAMES OF ELECTRICAL EQUIPMENT NOT SUPPLIED WITH GROUND LUGS THE CONTRACTOR SHALL DRILL REQUIRED HOLES FOR MOUNTING A BOLTED GROUND CONNECTOR. ALL BOLTED GROUND CONNECTORS SHALL BE BURNDY, OR EQUAL.
- BOND ALL NONCURRENT-CARRYING PARTS OF METAL EQUIPMENT TO GROUND SYSTEM.
- INSTALL GROUNDING ELECTRODE CONDUCTORS, LIGHTNING PROTECTION DOWN CONDUCTORS AND SEPARATE GROUND CONDUCTORS IN SCHEDULE 40 OR SCHEDULE 80 PVC CONDUIT OR EXPOSED WHERE ACCEPTABLE TO LOCAL CODES. WHERE GROUNDING ELECTRODE CONDUCTORS, LIGHTNING PROTECTION DOWN CONDUCTORS OR INDIVIDUAL GROUND CONDUCTORS ARE RUN IN PVC CONDUIT, DO NOT COMPLETELY ENCIRCLE CONDUIT WITH FERROUS AND/OR MAGNETIC MATERIALS. USE NON-METALLIC REINFORCED FIBERGLASS STRUT SUPPORT. WHERE METAL CONDUIT CLAMPS ARE INSTALLED, USE NYLON BOLTS, NUTS, WASHERS AND SPACERS TO INTERRUPT A COMPLETE METALLIC PATH FROM ENCIRCLING THE CONDUIT. THIS IS REQUIRED TO AVOID GIRDLING OF GROUND CONDUCTORS. GIRDLING OF A GROUND CONDUCTOR IS THE RESULT OF PLACING THE CONDUCTOR IN A RING OF MAGNETIC MATERIAL. THIS RING COULD BE A METALLIC CONDUIT, U-BOLT OR STRUT SUPPORT PIPE CLAMP, OR OTHER SUPPORT HARDWARE. THE RESULT OF GIRDLING GROUND CONDUCTORS SIGNIFICANTLY INCREASES THE INDUCTIVE IMPEDANCE OF THE GROUND CONDUCTOR. INDUCTIVE AND CAPACITIVE IMPEDANCE IS A TYPE OF RESISTANCE THAT OPPOSES THE FLOW OF ALTERNATING CURRENT. ANY INCREASE IN THE IMPEDANCE OF A GROUND CONDUCTOR REDUCES ITS ABILITY TO EFFECTIVELY MITIGATE RADIO FREQUENCY NOISE IN THE GROUND SYSTEM. THE CONDITION WHERE A GROUND CONDUCTOR IS GIRDLED DURING A LIGHTNING STRIKE RESULTS IN PHENOMENA KNOWN AS SURGE IMPEDANCE LOADING. SURGE IMPEDANCE LOADING IS A RESULT OF VOLTAGE AND CURRENT REACHING 500,000 VOLTS AND 10,000 AMPS FOR A SHORT DURATION. GIRDLING FURTHER INCREASES THE IMPEDANCE AT LIGHTNING FREQUENCIES OF 100 KILOHERTZ TO 100 MEGAHERTZ. AT THESE POWER AND FREQUENCY LEVELS ANY INCREASE IN THE IMPEDANCE OF THE GROUND CONDUCTOR MUST BE CONTROLLED. DURING LIGHTNING DISCHARGE CONDITIONS A LOW INDUCTIVE IMPEDANCE PATH IS MORE IMPORTANT THAN A LOW DC RESISTANCE PATH.
- IF LOCAL CODES DICTATE THAT INDIVIDUAL GROUNDING CONDUCTORS MUST BE RUN IN METAL CONDUIT OR RACEWAY, THEN THE CONDUIT OR RACEWAY MUST BE BONDED AT EACH END OF THE RUN WITH A BONDING JUMPER SIZED EQUAL TO THE INDIVIDUAL GROUNDING CONDUCTOR OR AS REQUIRED BY 2005 NEC 250-102. NOTE THIS DOES NOT APPLY TO AC EQUIPMENT GROUNDING CONDUCTORS RUN WITH AC CIRCUITS.
- WHERE A CONFLICT IS DETERMINED WITH RESPECT TO GROUNDING REQUIREMENTS PER MANUFACTURER INSTALLATION INSTRUCTIONS, NEC, AND/OR THE CONTRACT DOCUMENTS, CONTACT THE RESIDENT ENGINEER FOR FURTHER DIRECTIONS.

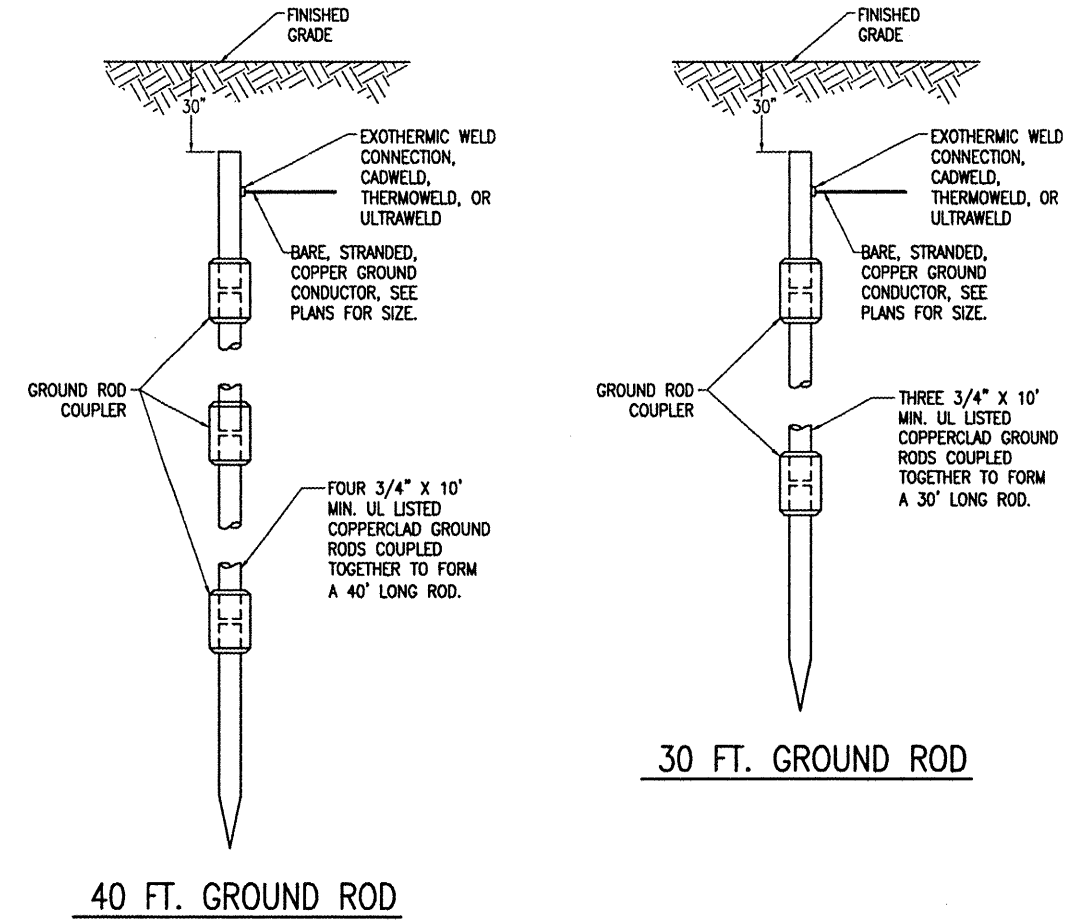

**GROUND RODS**  
(NOT TO SCALE)

- NOTES**
- TYPE AND MINIMUM NUMBER OF GROUND RODS SHALL BE AS SPECIFIED ON THE PLAN.
  - THE RESISTANCE TO GROUND OF THE GROUNDING SYSTEM SHALL NOT EXCEED 25 OHMS.
  - COST OF GROUND RODS IS INCIDENTAL TO THE ASSOCIATED ITEMS REQUIRING GROUNDING UNLESS OTHERWISE SPECIFIED. GROUND RODS FOR VAULT AND WIND CONE WILL BE CONSIDERED INCIDENTAL TO ITEM AR109200.
  - GROUND RODS SHALL BE SPACED AS DETAILED ON THE PLANS AND SHALL NOT BE SPACED LESS THAN ONE ROD LENGTH APART.
  - 30 FT. GROUND RODS ASSOCIATED WITH THE AWOS GROUNDING IMPROVEMENTS WILL BE PAID FOR UNDER ITEM AR800441 INSTALL 30-FOOT GROUND ROD.
  - 40 FT. GROUND RODS ASSOCIATED WITH THE AWOS GROUNDING IMPROVEMENTS WILL BE PAID FOR UNDER ITEM AR800442 INSTALL 40-FOOT GROUND ROD.

TR005

BY	
REVISION	
DATE	
<p><b>TRI-TOWNSHIP AIRPORT SAVANNA, CARROLL COUNTY ILLINOIS</b></p>	
<p>IL PROJ.: SFY-3782 A.I.P. PROJ.: 3-17-0091-814</p>	
<p>Project No. 07A0144D-0800                  E-004.DWG                  Scale NONE                  Date 05/13/08</p>	<p>LAYOUT KNL 01/02/08                  DRAWN MDR 01/02/08                  REVIEWED CAH 02/08/08</p>
<p><b>HANSON</b>                  Hanson Professional Services Inc.                  1525 South Sixth Street                  Springfield, Illinois 62703-2886                  Offices Nationwide</p>	
<p>CONSTRUCT NEW VAULT</p>	<p>GROUNDING NOTES</p>
<p><b>18</b> 18 of 24 sheets</p>	

MAY 13, 2008 8:25 PM WALLC00723  
 E:\AR\REPORTS\SAVANNA\07A0144\CAO\SHEETS\E-004.DWG - Work

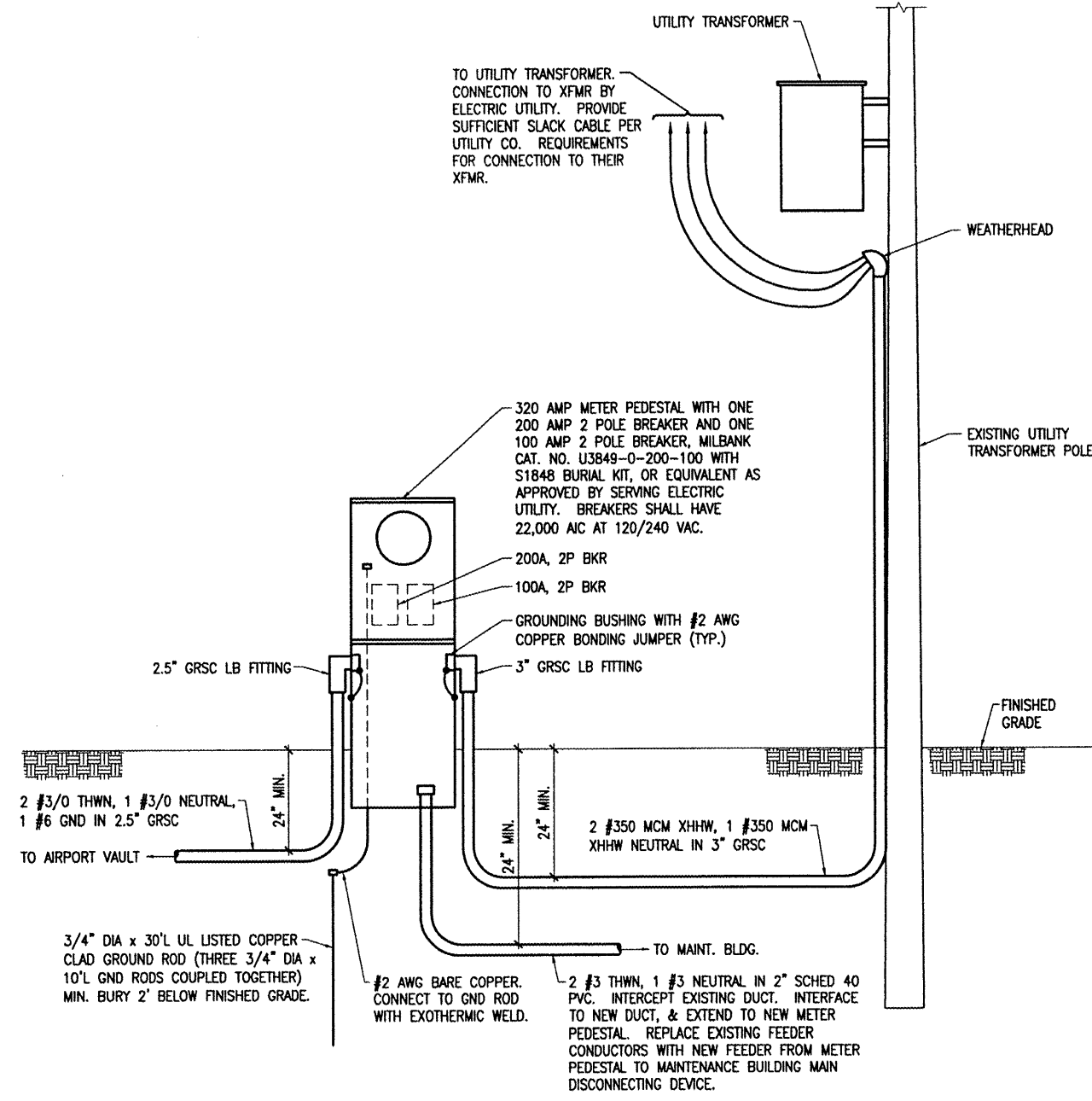

**SERVICE ENTRANCE ELEVATION**  
N.T.S.

**NOTES FOR ELECTRIC SERVICE**

1. CONTRACTOR SHALL COORDINATE SERVICE ENTRANCE WORK WITH THE SERVING ELECTRIC UTILITY; (JO-CARROLL ENERGY, 793 U.S. ROUTE 20 WEST, P.O. BOX 390, ELIZABETH, IL 61028, ATTN. MR. BOB PELELO, PHONE: 815-858-2207 EXT 249, CELL PHONE: 815-858-4142). SERVICE ENTRANCE WORK SHALL BE PAID FOR UNDER AR109200 INSTALL ELECTRICAL EQUIPMENT PER L.S. SERVICE ENTRANCE WORK SHALL ALSO BE COORDINATED WITH THE AIRPORT MANAGER.
2. CONTRACTOR SHALL COORDINATE ANY POWER OUTAGES WITH THE AIRPORT MANAGER.
3. EXISTING VAULT SERVICE METER BASE, DISCONNECT, SERVICE CONDUIT & WIRE, & FEEDER CONDUCTORS SHALL BE REMOVED & DISPOSED OF BY THE CONTRACTOR UPON TRANSFER OF POWER & AIRFIELD LIGHTING CIRCUITS TO THE NEW VAULT. EXISTING METER SHALL BE TURNED OVER TO SERVING ELECTRIC UTILITY. REMOVAL WORK SHALL BE PAID FOR UNDER AR109901 REMOVE ELECTRICAL VAULT PER L.S.

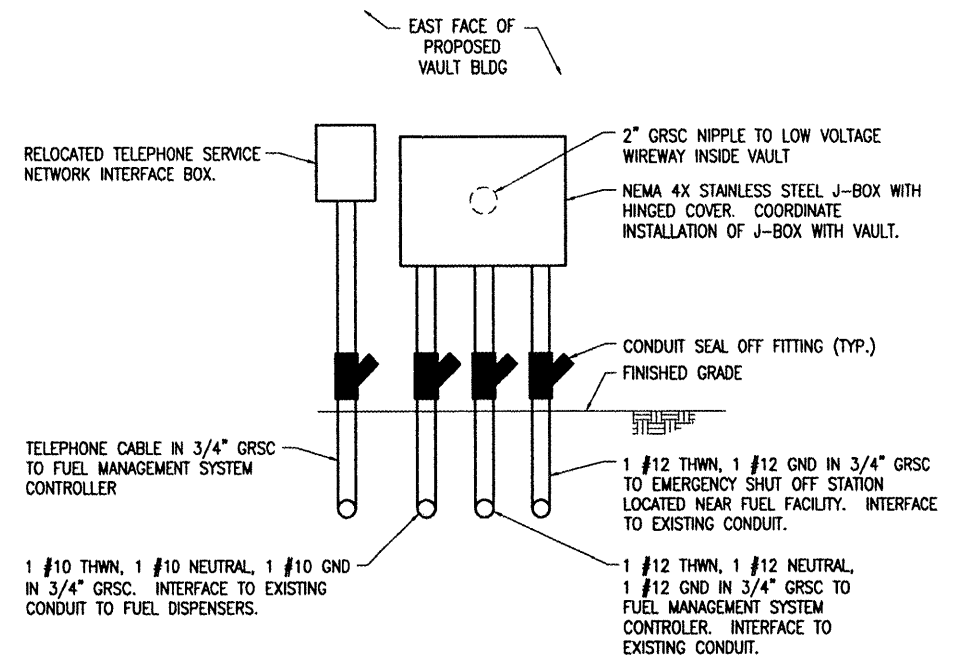

**NOTES**

1. REPLACE EXISTING POWER & CONTROL WIRING WITH NEW WIRING FROM THE PROPOSED VAULT TO THE EXISTING FUEL FACILITY. REPLACE EXISTING CONDUIT SEAL OFF FITTINGS AT THE FUEL FACILITY.
2. CONDUIT SEAL OFF FITTINGS SHALL BE UL LISTED OR FM APPROVED SUITABLE FOR CLASS I, DIV. 1, GROUP D LOCATION. PER UL STANDARD 886 & NEC 501.15(C)(6), THE CROSS-SECTIONAL AREA OF THE CONDUCTORS PERMITTED IN A SEAL SHALL NOT EXCEED 25 PERCENT OF THE CROSS-SECTIONAL AREA OF A RIGID METAL CONDUIT OF THE SAME TRADE SIZE UNLESS IT IS SPECIFICALLY IDENTIFIED FOR A HIGHER PERCENTAGE OF FILL.
3. COORDINATE RELOCATION OF TELEPHONE SERVICE WITH THE SERVING TELEPHONE COMPANY & THE AIRPORT MANAGER. THE SERVING TELEPHONE COMPANY IS GALLATIN RIVER COMMUNICATIONS, PHONE 1-800-371-6712.

**FUEL SYSTEM J-BOX ELEVATION AT VAULT BLDG**  
NOT TO SCALE

DATE	REVISION	BY

TRI-TOWNSHIP AIRPORT  
SAVANNA, CARROLL COUNTY  
ILLINOIS

IL PROJ.: SFY-3782 A.I.P. PROJ.: 3-17-0091-B14

HD Project No. 07A0144D_0800	01/02/08
Element E-505.DWG	01/03/08
Scale NONE	02/08/08
Date 05/13/08	
LAYOUT KNL	
DRAWN MW	
REVIEWED CAH	

Hanson Professional Services Inc.  
1525 South Sixth Street  
Springfield, Illinois 62705-2886  
Offices Nationwide

CONSTRUCT  
NEW VAULT  
ELECTRICAL DETAILS  
SHEET 1

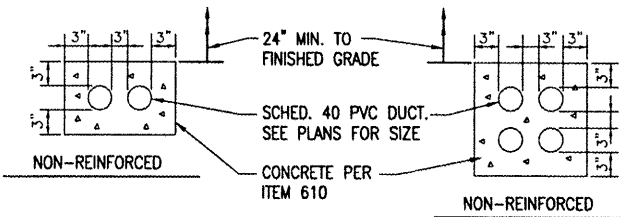
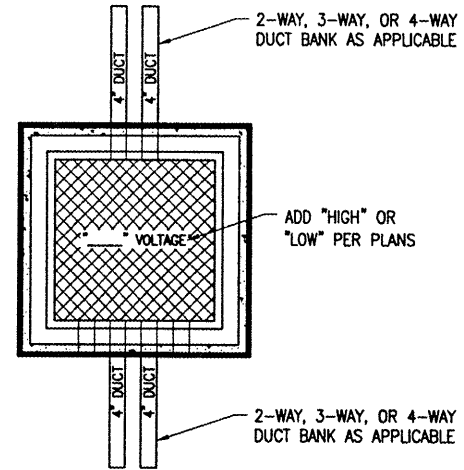

**NOTES:**

1. ALL DIMENSIONS ARE MINIMUM.
2. INCLUDE DUCT SPACERS AS MANUFACTURED BY UNDERGROUND DEVICES INC., TO MAINTAIN PROPER SEPARATION OF CONDUITS.

**CONCRETE ENCASED DUCT DETAIL**  
(2-WAY & 4-WAY SHOWN)

THE LOCATION OF UNDERGROUND UTILITIES AS INDICATED ON THE PLANS HAS BEEN OBTAINED FROM EXISTING RECORDS. NEITHER THE OWNER NOR THE ENGINEER ASSUMES ANY RESPONSIBILITY WHATSOEVER, IN RESPECT TO THE ACCURACY OR SUFFICIENCY OF THE INFORMATION AND THERE IS NO GUARANTEE, EITHER EXPRESSED OR IMPLIED, THAT THE CONDITIONS ARE REPRESENTATIVE OF THOSE TO BE ENCOUNTERED IN THE CONSTRUCTION.

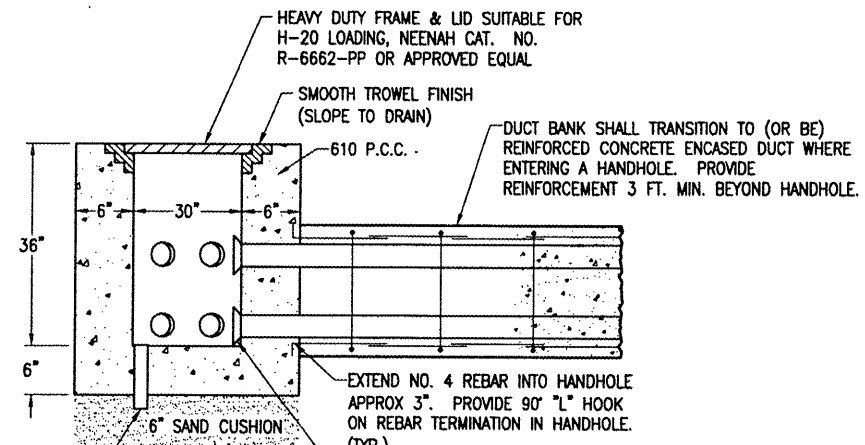

2" SCHED 40 PVC DRAIN PIPE. NOTE 6" OF CA-7 GRAVEL MAY BE PROVIDED, INSTEAD OF 6" CONCRETE FLOOR WITH DRAIN PIPE, AT CONTRACTORS OPTION.

**NOTE:**

1. LIDS FOR LOW VOLTAGE HANDHOLES SHALL BE LABELED "LOW VOLTAGE". LIDS FOR HIGH VOLTAGE HANDHOLES SHALL BE LABELED "HIGH VOLTAGE". COORDINATE LETTERING WITH MFR.
2. HANDHOLE MAY BE CAST IN PLACE OR PRECAST.
3. SEE SPECIAL PROVISIONS.

**ELECTRICAL HANDHOLE**  
"NOT TO SCALE"

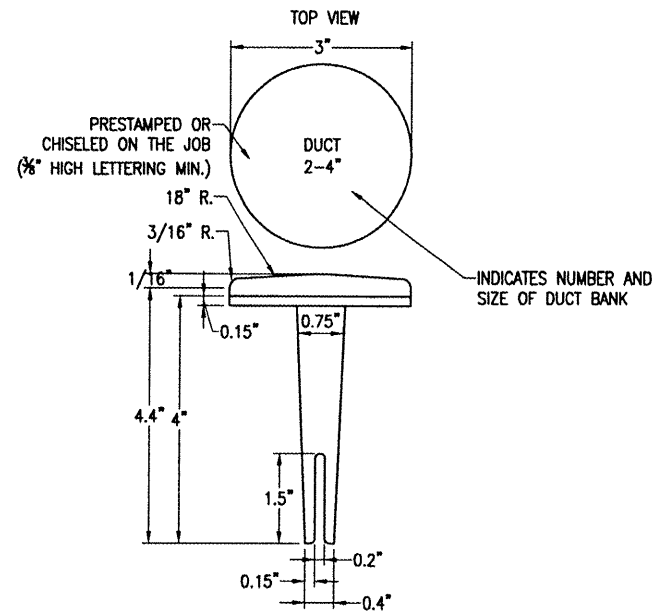

**BITUMINOUS PAVEMENT DUCT MARKERS**  
"NOT TO SCALE"

**NOTE:** TOP OF MARKER SHALL BE FLUSH WITH FINISHED PAVEMENT SURFACE. MARKER MAY BE INSTALLED IN A DRILLED HOLE AND SECURED WITH EPOXY GLUE.

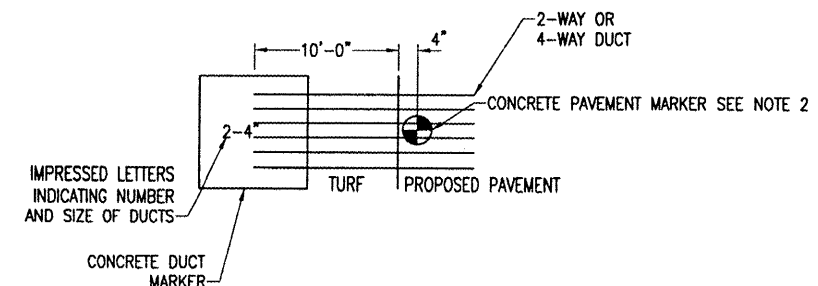

**DUCT MARKER DETAIL**  
"NOT TO SCALE"

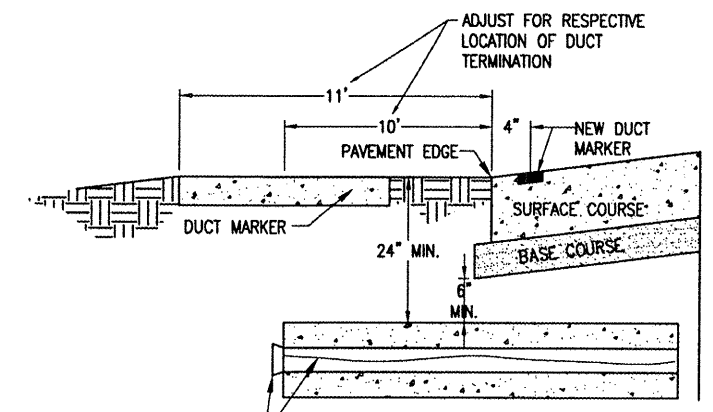

#10 PULL WIRE COIL A MINIMUM OF 3' AT DUCT ENDS. INSTALL APPROVED PLUGS IN END OF DUCTS NOT USED.

**UNDERGROUND ELECTRICAL DUCT**  
"NOT TO SCALE"

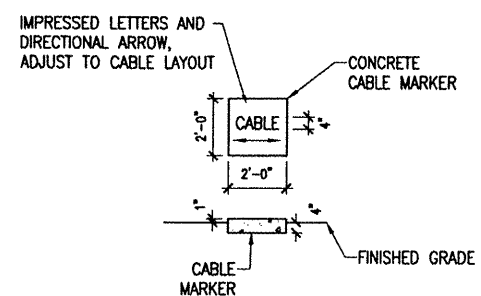

**TURF CABLE MARKERS**  
"NOT TO SCALE"

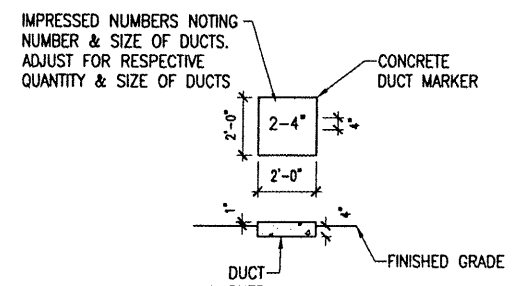

**DUCT MARKERS**  
"NOT TO SCALE"

**NOTES:**

1. THE COST OF ALL TURF AND PAVEMENT DUCT MARKERS SHALL BE INCIDENTAL TO THE DUCT. THE COST OF ALL CABLE MARKERS SHALL BE INCIDENTAL TO THE CABLE.
2. BITUMINOUS PAVEMENT DUCT MARKER AND CONCRETE DUCT MARKER TO BE PROVIDED AT EACH END OF EACH DUCT AS SHOWN ON THE LOCATION PLAN. FOR CONCRETE PAVEMENT, THE LETTER "D" SHALL BE IMPRESSED IN THE PAVEMENT INSTEAD OF THE MARKER. THE LETTER SHALL BE IMPRESSED AS DESCRIBED IN NOTE 4.
3. CABLE MARKERS SHALL BE PLACED AT CHANGES OF DIRECTION AND APPROXIMATELY EVERY 200' ALONG CABLE RUNS.
4. CONCRETE CABLE MARKERS AND DUCT MARKERS SHALL HAVE LETTERS 4" HIGH, 3" WIDE WITH WIDTH OF STROKE 1/2" AND 1/4" DEEP. ALL LETTERS, NUMBERS AND ARROWS TO BE IMPRESSED.

BY	REVISION	DATE

TRI-TOWNSHIP AIRPORT  
SAVANNA, CARROLL COUNTY  
ILLINOIS

H/I Project No. 07A0144D_0800	01/02/08
File Name E-501.DWG	01/02/08
Scale NONE	02/08/08
Date 05/13/08	
LAYOUT KNL	
DRAWN MOR	
REVIEWED CAH	

**HANSON**  
Hanson Professional Services Inc.  
1525 South Sixth Street  
Springfield, Illinois 62705-2888  
Offices Nationwide

CONSTRUCT  
NEW VAULT  
ELECTRICAL DETAILS  
SHEET 2



MAY 13, 2008 3:34 PM KINCA00394  
 I:\AIRPORTS\SAVANNA\07A0144\CAD\ SHEETS\E-502.DWG - Work

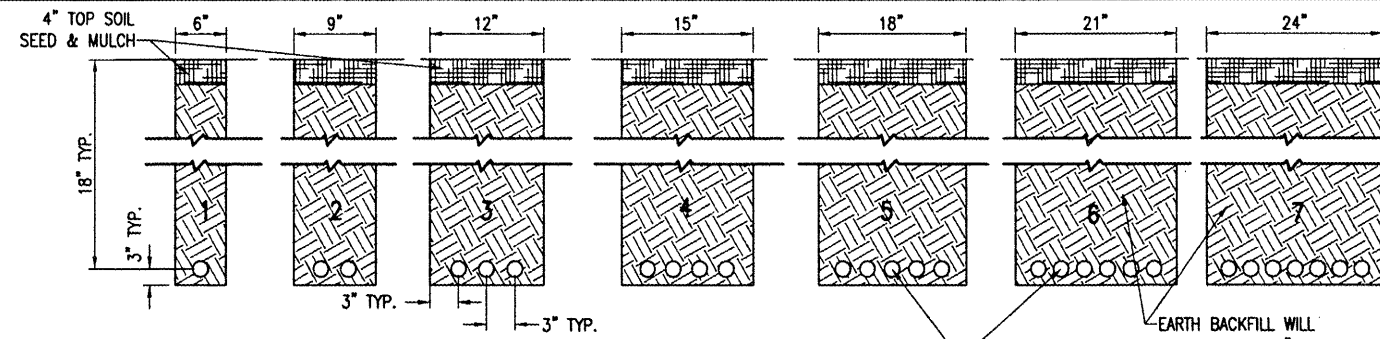

**NOTES:**  
 DETAIL NUMBERS INDICATE NO. OF CABLES.  
 TRENCHES WITH MORE THAN SEVEN CABLES SHALL BE INCREASED 3" IN WIDTH FOR EACH ADDITIONAL CABLE; IF SPECIFIED ON PLANS TWO PARALLEL TRENCHES MAY BE CONSTRUCTED.  
 DEPTH OF TRENCHES SHALL BE AS SHOWN ABOVE UNLESS OTHERWISE SPECIFIED ON THE PLANS.  
 ALL DISTURBED SURFACES SHALL BE RESTORED TO THEIR ORIGINAL CONDITION. COST IS INCIDENTAL TO TRENCH.

**CABLE TRENCHES**  
 (NOT TO SCALE)

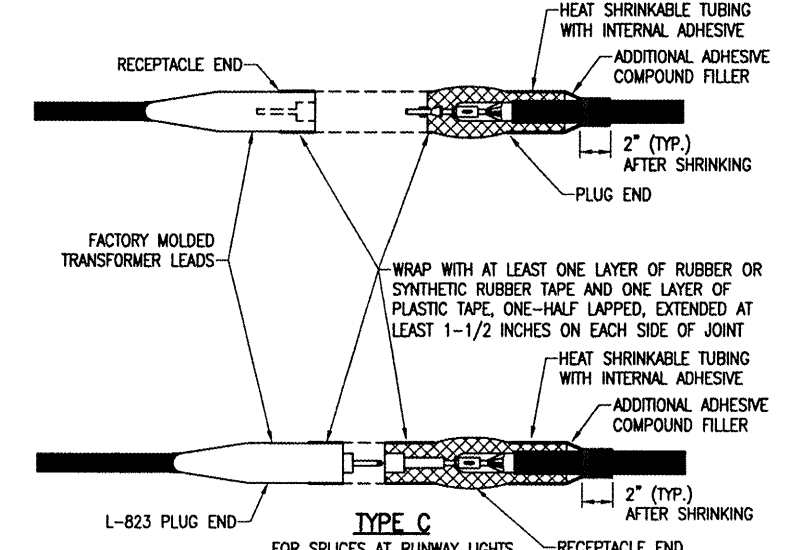
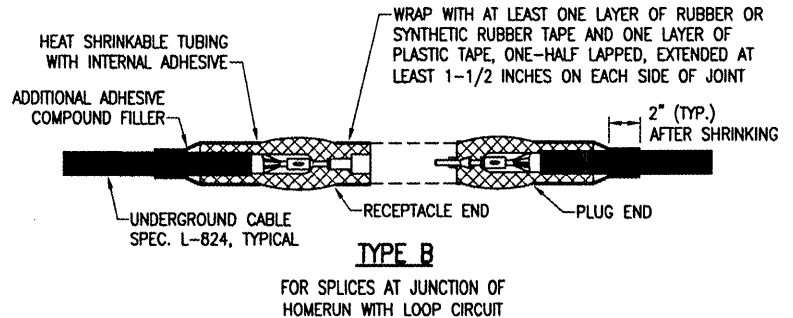
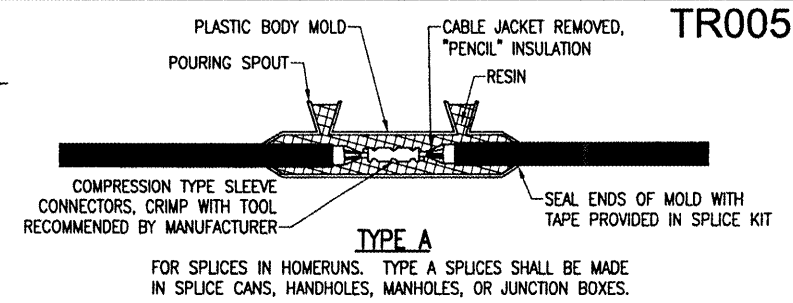
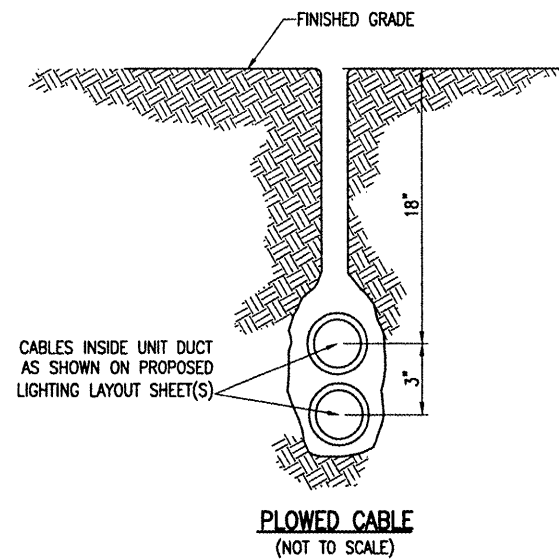

**NOTES:**  
 SEE PROPOSED LIGHTING LAYOUT SHEET(S) FOR SPLICE TYPE.  
 INSIDE DIAMETER OF CONNECTOR SHALL PROPERLY MATCH THE OUTSIDE DIAMETER OF CABLE.  
**CABLE SPLICES**  
 (NOT TO SCALE)

THE LOCATION, SIZE AND TYPE OF MATERIAL OF EXISTING UNDERGROUND UTILITIES INDICATED ON THE PLANS IS NOT REPRESENTED AS BEING ACCURATE, SUFFICIENT OR COMPLETE. IT SHALL BE THE CONTRACTOR'S RESPONSIBILITY TO DETERMINE THE ACTUAL LOCATION OF ALL SUCH FACILITIES, INCLUDING SERVICE CONNECTIONS TO UNDERGROUND UTILITIES. PRIOR TO CONSTRUCTION, THE CONTRACTOR SHALL NOTIFY THE UTILITY COMPANIES OF HIS OPERATIONAL PLANS AND SHALL OBTAIN FROM THE RESPECTIVE UTILITY COMPANIES DETAILED INFORMATION AND ASSISTANCE RELATIVE TO THE LOCATION OF THEIR FACILITIES AND THE WORKING SCHEDULE OF THE COMPANIES FOR REMOVAL OR ADJUSTMENT WHERE REQUIRED. IN THE EVENT AN UNEXPECTED UTILITY INTERFERENCE IS ENCOUNTERED DURING CONSTRUCTION, THE CONTRACTOR SHALL IMMEDIATELY NOTIFY THE UTILITY COMPANY OF JURISDICTION. THE ENGINEER SHALL ALSO BE IMMEDIATELY NOTIFIED. ANY SUCH MAINS AND SERVICES SHALL BE RESTORED TO SERVICE AT ONCE AND PAID FOR BY THE CONTRACTOR AT NO ADDITIONAL COST TO THE CONTRACT.

CALL J.U.L.I.E. FOR UTILITY INFORMATION AT 1-800-892-0123. CONTACT AIRPORT PERSONNEL FOR ASSISTANCE IN LOCATING AIRPORT CABLES. CONTACT FAA FOR ASSISTANCE IN LOCATING FAA CABLES

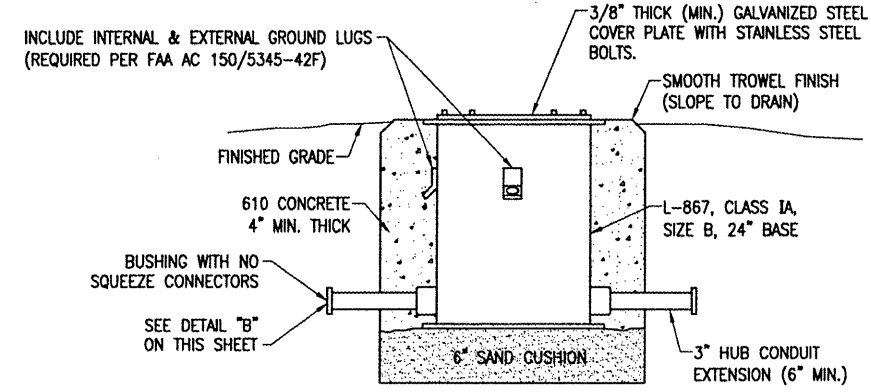

**SPLICE CAN DETAIL**  
 (NOT TO SCALE)

**NOTES**  
 1. SPLICE CANS SHALL BE LOCATED AS DETAILED ON THE PLANS.  
 2. ADDITIONAL SPLICE CANS REQUIRED FOR EXISTING CABLES CUT AND REPAIRED OR TO ACCOMMODATE CABLE RESPECTIVE INSTALLATION SHALL BE INCIDENTAL TO THAT RESPECTIVE PAY ITEM OR REPAIR WORK.

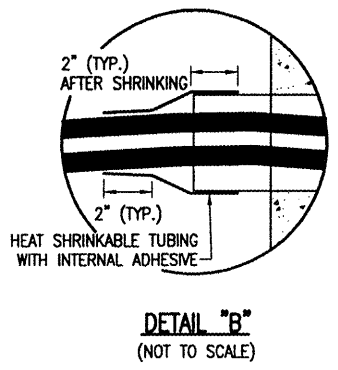

**DETAIL "B"**  
 (NOT TO SCALE)

BY	
REVISION	
DATE	

TRI-TOWNSHIP AIRPORT  
 SAVANNA, CARROLL COUNTY  
 ILLINOIS  
 I.L. PROJ.: SFY-3782 A.I.P. PROJ.: 3-17-0091-B14

ISS. Project No.	07A01440_0800
Electronic	E-502.DWG
Scale	NONE
Date	05/13/08
LAYOUT	KNL 01/02/08
DRAWN	MDR 01/02/08
REVIEWED	CAH 02/09/08

**HANSON**  
 Hanson Professional Services Inc.  
 1525 South Sixth Street  
 Springfield, Illinois 62703-2886  
 Offices Nationwide

CONSTRUCT  
 NEW VAULT  
 ELECTRICAL DETAILS  
 SHEET 3

**GENERAL NOTES**

- ALL ELECTRICAL EQUIPMENT SHALL BE INSTALLED IN CONFORMANCE WITH NFPA 70 - NATIONAL ELECTRICAL CODE (NEC) MOST CURRENT ISSUE IN FORCE, THE RESPECTIVE EQUIPMENT MANUFACTURER'S DIRECTIONS AND ALL OTHER APPLICABLE LOCAL CODES, LAWS, ORDINANCES, AND REQUIREMENTS IN FORCE. ANY INSTALLATIONS WHICH VOID THE U.L. LISTING, ETL LISTING (OR OTHER THIRD PARTY LISTING) AND/OR THE MANUFACTURER'S WARRANTY OF A DEVICE WILL NOT BE PERMITTED.
- CONTRACTOR SHALL KEEP A COPY OF THE LATEST NEC IN FORCE ON SITE AT ALL TIMES DURING CONSTRUCTION FOR USE AS A REFERENCE.
- CONTRACTOR SHALL COORDINATE WORK AND ANY POWER OUTAGES WITH THE RESPECTIVE FACILITY OWNER PERSONNEL AND THE AIRPORT MANAGER.
- THE CONTRACTOR SHALL ASCERTAIN THAT ALL LIGHTING SYSTEM COMPONENTS FURNISHED BY HIM, INCLUDING FAA APPROVED EQUIPMENT, ARE COMPATIBLE IN ALL RESPECTS WITH EACH OTHER AND THE REMAINDER OF THE NEW/EXISTING SYSTEM. ANY NONCOMPATIBLE COMPONENTS FURNISHED BY THIS CONTRACTOR SHALL BE REPLACED BY HIM AT NO ADDITIONAL COST TO THE AIRPORT SPONSOR WITH A SIMILAR UNIT, APPROVED BY THE ENGINEER (DIFFERENT MODEL OR DIFFERENT MANUFACTURER) THAT IS COMPATIBLE WITH THE REMAINDER OF THE AIRPORT LIGHTING SYSTEM.
- IN CASE THE CONTRACTOR ELECTS TO FURNISH AND INSTALL AIRPORT LIGHTING EQUIPMENT REQUIRING ADDITIONAL WIRING, TRANSFORMERS, ADAPTORS, MOUNTINGS, ETC., TO THOSE SHOWN ON THE DRAWINGS AND/OR LISTED IN THE SPECIFICATION, ANY COST FOR THESE ITEMS SHALL BE INCIDENTAL TO THE EQUIPMENT COST.
- THE CONTRACTOR INSTALLED EQUIPMENT (INCLUDING FAA APPROVED) SHALL NOT GENERATE ANY ELECTROMAGNETIC INTERFERENCE IN THE EXISTING AND/OR NEW COMMUNICATIONS, WEATHER, AIR NAVIGATION, AND AIR TRAFFIC CONTROL EQUIPMENT. ANY EQUIPMENT GENERATING SUCH INTERFERENCE SHALL BE REPLACED BY THE CONTRACTOR AT NO ADDITIONAL COST WITH THE EQUIPMENT MEETING THE APPLICABLE SPECIFICATIONS AND NOT GENERATING ANY INTERFERENCE.
- WHEN A SPECIFIC TYPE, STYLE, CLASS, ETC. OF FAA APPROVED EQUIPMENT IS SPECIFIED ONLY THAT TYPE, STYLE, CLASS, WILL BE ACCEPTABLE, EVEN THOUGH EQUIPMENT OF OTHER TYPES STYLES, CLASSES, ETC. MAY BE APPROVED.
- ANY AND ALL INSTRUCTIONS FROM THE ENGINEER TO THE CONTRACTOR REGARDING CHANGES IN OR DEVIATIONS FROM THE PLANS AND SPECIFICATIONS SHALL BE IN WRITING WITH COPIES SENT TO THE AIRPORT SPONSOR AND THE FAA FIELD OFFICE (ADO/AFO). THE CONTRACTOR SHALL NOT ACCEPT ANY VERBAL INSTRUCTIONS FROM THE RESIDENT ENGINEER REGARDING ANY CHANGES FROM THE PLANS AND SPECIFICATIONS.
- A MINIMUM OF THREE COPIES OF THE INSTRUCTION BOOK SHALL BE SUPPLIED WITH EACH DIFFERENT TYPE OF EQUIPMENT. THE BOOKS DESCRIBING A MORE SOPHISTICATED TYPE OF EQUIPMENT, SUCH AS REGULATORS, PAPI, REIL, ETC. AS A MINIMUM SHALL CONTAIN THE FOLLOWING:
  - A DETAILED DESCRIPTION OF THE OVERALL EQUIPMENT AND ITS INDIVIDUAL COMPONENTS.
  - THEORY OF OPERATION INCLUDING THE FUNCTION OF EACH COMPONENT.
  - INSTALLATION INSTRUCTION.
  - START-UP INSTRUCTIONS.
  - PREVENTATIVE MAINTENANCE REQUIREMENTS.
  - CHART FOR TROUBLE-SHOOTING.
  - COMPLETE POWER AND CONTROL DETAILED WIRING DIAGRAM(S), SHOWING EACH CONDUCTOR/CONNECTION/COMPONENT - "BLACK" BOXES ARE NOT ACCEPTABLE. THE DIAGRAM OF THE NARRATIVE SHALL SHOW VOLTAGE/CURRENTS/WAVE SHAPES AT STRATEGIC LOCATIONS TO BE USED WHEN CHECKING AND/OR TROUBLE-SHOOTING THE EQUIPMENT. WHEN THE EQUIPMENT HAS SEVERAL MODES OF OPERATION, SUCH AS SEVERAL BRIGHTNESS STEPS, THESE PARAMETERS SHALL BE INDICATED FOR ALL DIFFERENT MODES.
  - PARTS LIST WHICH WILL INCLUDE ALL MAJOR AND MINOR COMPONENTS SUCH AS RESISTORS, DIODES, ETC. IT SHALL INCLUDE A COMPLETE NOMENCLATURE OF EACH COMPONENT AND, IF APPLICABLE, THE NAME OF ITS MANUFACTURER AND THE CATALOG NUMBER.
  - SAFETY INSTRUCTIONS.

**POWER AND CONTROL NOTES**

- PROVIDE LEGEND PLATES FOR ALL ELECTRICAL EQUIPMENT TO IDENTIFY FUNCTION, CIRCUIT VOLTAGE AND PHASE. WHERE THE EQUIPMENT CONTAINS FUSES, ALSO IDENTIFY THE FUSE OR FUSE LINK AMPERE RATING. WHERE THE EQUIPMENT DOES NOT HAVE SUFFICIENT AREA TO INSTALL LEGEND PLATES, THE LEGEND PLATES SHALL BE INSTALLED ON THE WALL NEXT TO THE UNIT. LEGEND PLATES SHALL BE WEATHERPROOF ENGRAVED PLASTIC OR PHENOLIC MATERIAL, 1/4" HIGH BLACK LETTERS ON A WHITE BACKGROUND UNLESS NOTED OTHERWISE. SECURE WITH WEATHERPROOF ADHESIVE AND MACHINE SCREWS. FURNISH ADDITIONAL LEGEND PLATES WHERE REQUIRED BY CODE, FOR ADDITIONAL EQUIPMENT, AS DETAILED HEREIN ON THE PLANS, AND AS NOTED IN THE SPECIAL PROVISION SPECIFICATIONS.
- COLOR CODE ALL PHASE WIRING BY THE USE OF COLORED WIRE INSULATION AND/OR COLORED TAPE. WHERE TAPE IS USED, THE WIRE INSULATION SHALL BE BLACK. BLACK AND RED SHALL BE USED FOR SINGLE-PHASE, THREE WIRE SYSTEMS AND BLACK, RED AND BLUE SHALL BE USED FOR THREE-PHASE SYSTEMS. NEUTRAL CONDUCTORS, SIZE NO. 6 AWG OR SMALLER, SHALL BE IDENTIFIED BY A CONTINUOUS WHITE OR NATURAL GRAY OUTER FINISH ALONG ITS ENTIRE LENGTH. NEUTRAL CONDUCTORS LARGER THAN NO. 6 AWG SHALL BE IDENTIFIED EITHER BY A CONTINUOUS WHITE OR NATURAL GRAY OUTER FINISH ALONG ITS ENTIRE LENGTH OR BY THE USE OF WHITE TAPE AT ITS TERMINATIONS AND INSIDE ACCESSIBLE WIREWAYS. INSULATED GROUND CONDUCTORS SHALL HAVE GREEN COLORED INSULATION FOR ALL CONDUCTOR SIZES (AWG OR KCMIL).
- ALL BRANCH CIRCUIT CONDUCTORS CONNECTED TO A PARTICULAR PHASE SHALL BE IDENTIFIED WITH THE SAME COLOR. THE COLOR CODING SHALL BE EXTENDED TO THE POINT OF UTILIZATION.
- IN CONTROL WIRING THE SAME COLOR SHALL BE USED THROUGHOUT THE SYSTEM FOR THE SAME FUNCTION, SUCH AS 10%, 30%, 100% BRIGHTNESS CONTROL, ETC.
- LOW VOLTAGE (600 V.) AND HIGH VOLTAGE (5000 V.) CONDUCTORS SHALL BE INSTALLED IN SEPARATE WIREWAYS.
- NEATLY LACE WIRING IN DISTRIBUTION PANELS, WIREWAYS, SWITCHES AND JUNCTION/PULL BOXES.
- THE MINIMUM SIZE OF PULL/JUNCTION BOXES, REGARDLESS OF THE QUANTITY AND SIZE OF THE CONDUCTORS SHOWN, SHALL BE AS FOLLOWS:
  - IN STRAIGHT PULLS THE LENGTH OF THE BOX SHALL NOT BE LESS THAN EIGHT TIMES THE TRADE DIAMETER OF THE LARGER CONDUIT. THE TOTAL AREA (INCLUDING THE CONDUIT CROSS-SECTIONAL AREA) OF A BOX END SHALL BE AT LEAST 3 TIMES GREATER THAN THE TOTAL TRADE CROSS-SECTIONAL AREA OF THE CONDUITS TERMINATING AT THE END.
  - IN ANGLE PULLS OR 'U' PULLS THE DISTANCE BETWEEN EACH CONDUIT ENTRY INSIDE THE BOX AND THE OPPOSITE WALL OF THE BOX SHALL NOT BE LESS THAN SIX (6) TIMES THE TRADE DIAMETER OF THE LARGEST CONDUIT. THIS DISTANCE SHALL BE INCREASED FOR ADDITIONAL ENTRIES BY THE AMOUNT OF THE SUM OF THE DIAMETERS OF ALL OTHER CONDUIT ENTRIES ON THE SAME WALL AS THE BOX. THE DISTANCE BETWEEN CONDUIT ENTRIES ENCLOSING THE SAME CONDUCTOR SHALL NOT BE LESS THAN SIX TIMES THE TRADE DIAMETER OF THE LARGEST CONDUIT.
- A RUN OF CONDUIT BETWEEN TERMINATIONS AT EQUIPMENT ENCLOSURES, SQUARE DUCTS AND PULL/JUNCTION BOXES, SHALL NOT CONTAIN MORE THAN THE EQUIVALENT OF FOUR QUARTER BENDS (360 DEGREES TOTAL), INCLUDING THOSE BENDS LOCATED IMMEDIATELY AT THE TERMINATIONS, CAST, CONDUIT TYPE OUTLETS SHALL NOT BE TREATED AS PULL/JUNCTION BOXES.
- EQUIPMENT CABINETS SHALL NOT BE USED AS PULL/JUNCTION BOXES. ONLY WIRING TERMINATING AT THE EQUIPMENT SHALL BE BROUGHT INTO THESE ENCLOSURES.
- SPLICES AND JUNCTION POINTS SHALL BE PERMITTED ONLY IN JUNCTION BOXES, DUCTS EQUIPPED WITH REMOVABLE COVERS, AND AT EASILY ACCESSIBLE LOCATIONS.
- CIRCUIT BREAKERS IN POWER DISTRIBUTION PANEL(S) SHALL BE THERMAL-MAGNETIC MOLDED CASE, PERMANENT TRIP WITH 100 AMPERE, MINIMUM FRAME.
- DUAL LUGS SHALL BE USED WHERE TWO (2) WIRES, SIZE NO. 6 OR LARGER, ARE TO BE CONNECTED TO THE SAME TERMINAL.
- ALL INTERIOR WALL MOUNTED EQUIPMENT ENCLOSURES SHALL BE MOUNTED ON HOT DIPPED GALVANIZED STEEL STRUT SUPPORT, OR STAINLESS STEEL STRUT SUPPORT, WITH CORROSION RESISTANT HARDWARE.
- SUPPORT FOR EXTERIOR MOUNTED EQUIPMENT SHALL USE HOT DIPPED GALVANIZED STEEL STRUT SUPPORT OR STAINLESS STEEL STRUT SUPPORT WITH STAINLESS STEEL HARDWARE. PROVIDE ZINC RICH PAINT APPLIED TO FIELD CUTS OF GALVANIZED STEEL SUPPORT TO MINIMIZE THE POTENTIAL FOR CORROSION PER THE RESPECTIVE STRUT SUPPORT MANUFACTURER'S RECOMMENDATIONS.

- CONDUITS FOR ELECTRIC SERVICE ENTRANCE AND FEEDERS SHALL BE AS DETAILED HEREIN ON THE PLANS. WHERE GALVANIZED RIGID STEEL CONDUIT IS SPECIFIED IT SHALL HAVE THREADED FITTINGS. SET SCREW TYPE FITTINGS WILL NOT BE ACCEPTABLE. CONDUITS FOR UNDERGROUND APPLICATIONS SHALL BE AS DETAILED HEREIN. CONDUITS FOR GROUNDING ELECTRODE CONDUCTORS OR INDIVIDUAL GROUNDING CONDUCTORS SHALL BE SCHEDULE 40 OR SCHEDULE 80 PVC.
- PROVIDE LIQUID TIGHT FLEXIBLE METAL CONDUIT AT CONNECTIONS TO EQUIPMENT SUBJECT TO VIBRATION OR WHERE FLEXIBILITY IS REQUIRED. LIQUID TIGHT FLEXIBLE METAL CONDUIT AND ASSOCIATED FITTINGS SHALL BE U.L. LISTED TO MEET THE REQUIREMENTS OF NEC 350.6, SUITABLE FOR GROUNDING, SUNLIGHT RESISTANT, AND RESISTANT TO OIL, GASOLINE, AND GREASE. LIQUID TIGHT FLEXIBLE METAL CONDUIT THAT IS USED FOR FLEXIBILITY (INCLUDING CONNECTIONS TO MOTORS, TRANSFORMERS, & CONSTANT CURRENT REGULATORS) SHALL REQUIRE AN EXTERNAL BONDING JUMPER OR INTERNAL EQUIPMENT GROUNDING CONDUCTOR PER NEC 350.60. DO NOT INSTALL LIQUID TIGHT FLEXIBLE METAL CONDUIT THAT IS NOT UL LISTED.
- UNLESS OTHERWISE SHOWN, ALL EXPOSED CONDUITS SHALL BE RUN PARALLEL TO OR AT RIGHT ANGLES WITH THE LINES OF THE STRUCTURE.
- ALL STEEL CONDUITS, FITTINGS, NUTS, BOLTS, ETC. SHALL BE GALVANIZED.
- USE CONDUIT BUSHINGS AT EACH CONDUIT TERMINATION. WHERE NO. 4 AWG OR LARGER UNDERGROUND WIRE IS INSTALLED, USE INSULATED BUSHINGS.
- USE DOUBLE LOCK NUTS AT EACH CONDUIT TERMINATION.
- WRAP ALL PRIMARY AND SECONDARY POWER TRANSFORMER CONNECTIONS WITH SUFFICIENT LAYERS OF INSULATING TAPE (3M SCOTCH 23 ALL-VOLTAGE SPLICING TAPE, 3M SCOTCH 130C LINERLESS RUBBER SPLICING TAPE, OR APPROVED EQUAL) AND COVER WITH VINYL ELECTRICAL TAPE (3M SCOTCH 88 VINYL ELECTRICAL TAPE OR APPROVED EQUAL) FOR FULL VALUE OF CABLE INSULATION VOLTAGE.
- UNLESS OTHERWISE NOTED, ALL SINGLE CONDUCTOR CONTROL WIRING SHALL BE NO. 12 AWG. COPPER MINIMUM.
- THE FOLLOWING SHALL APPLY TO RELAY/CONTACTOR PANELS/ENCLOSURES:
  - FOR INTERIOR LOCATIONS ALL COMPONENTS SHALL BE MOUNTED IN NEMA 12 (DUST TIGHT) ENCLOSURE(S) WITH VERTICALLY HINGED COVERS. FOR EXTERIOR/OUTDOOR LOCATIONS ALL COMPONENTS SHALL BE MOUNTED IN NEMA 4X STAINLESS STEEL ENCLOSURE(S) WITH VERTICALLY HINGED COVERS. ALL CONDUIT ENTRIES INTO NEMA 4, 4X ENCLOSURES SHALL HAVE NEMA 4 HUBS LISTED SUITABLE FOR THE RESPECTIVE ENCLOSURE TO MAINTAIN THE NEMA 4, 4X RATING OF THE ENCLOSURE.
  - THE ENCLOSURE(S) SHALL HAVE AMPLE SPACE FOR THE CIRCUIT COMPONENTS, TERMINAL BLOCKS AND INCOMING AND INTERNAL WIRING.
  - ALL CONTROL CONDUCTOR TERMINATIONS SHALL BE OF THE OPEN-EYE CONNECTOR/SCREW TYPE. SOLDERED CLOSED-EYE TERMINATIONS, OR TERMINATIONS WITHOUT CONNECTORS ARE NOT ACCEPTABLE.
  - WHEN THE ENCLOSURE COVER IS OPENED, ALL CIRCUIT COMPONENTS, WIRING AND TERMINALS SHALL BE EXPOSED AND ACCESSIBLE WITHOUT REMOVAL OF ANY PANELS, COVERS, ETC., EXCEPT THOSE COVERING HIGH VOLTAGE COMPONENTS.
  - ACCESS TO, OR REMOVAL OF A CIRCUIT COMPONENT OR TERMINAL BLOCK WILL NOT REQUIRE THE REMOVAL OF ANY OTHER CIRCUIT COMPONENT OR TERMINAL BLOCK.
  - EACH CIRCUIT COMPONENT SHALL BE CLEARLY IDENTIFIED INDICATING ITS CORRESPONDING NUMBER SHOWN ON THE DRAWINGS AND ITS FUNCTION.
  - A COMPLETE WIRING DIAGRAM SHALL BE MOUNTED ON THE INSIDE OF THE COVER. THE DIAGRAM SHALL REPRESENT EACH CONDUCTOR BY A SEPARATE LINE.
  - THE DIAGRAM SHALL IDENTIFY EACH CIRCUIT COMPONENT AN NUMBERING AND COLOR OF EACH TERMINAL CONDUCTOR AND TERMINAL.
  - ALL WIRING SHALL BE NEATLY TRAINED AND LACED.
  - MINIMUM WIRE SIZE SHALL BE NO. 12 AWG.
- FURNISH & INSTALL A WEATHERPROOF WARNING LABEL FOR EACH METER SOCKET, SERVICE DISCONNECT, SAFETY SWITCH, CUTOFF, PANELBOARD, & CONTROL PANEL TO WARN PERSONS OF POTENTIAL ELECTRIC ARC FLASH HAZARDS, PER THE REQUIREMENTS OF NEC 110.16 "FLASH PROTECTION".

DATE	REVISION	BY

TRI-TOWNSHIP AIRPORT  
SAVANNA, CARROLL COUNTY  
ILLINOIS

IL PROJ.: SFY-3782 A.I.P. PROJ.: J-17-0091-814

HD Project No. 07A0144D_0800	Element E-002.DWG	Scale NONE	Date 05/13/08	LAYOUT KNL 01/02/08	REVIEWED CAH 02/08/08
				DRAWN MDR 01/02/08	



CONSTRUCT  
NEW VAULT

ELECTRICAL NOTES  
SHEET 1

MAY 13, 2008 3:36 PM KINCA00394  
I:\AIRPORTS\SAVANNA\07A0144\CAO\SHEETS\E-002.DWG - Work

**AIRFIELD LIGHTING NOTES**

1. UNLESS OTHERWISE NOTED, ALL UNDERGROUND AIRFIELD LIGHTING SERIES CIRCUIT CONDUCTORS WHETHER DEB OR IN DUCT/CONDUIT SHALL BE FAA APPROVED 5000 VOLT L-824 TYPE. ALL UNDERGROUND FIELD POWER LOW VOLTAGE (600 VOLT & BELOW) CIRCUIT CONDUCTORS WHETHER DEB OR IN DUCT/CONDUIT SHALL BE UL LISTED 600 VOLT, TYPE XLP-USE-2 COPPER CONDUCTORS. CONDUCTOR SIZES SHALL BE AS SPECIFIED, HEREIN.
2. NO COMPONENTS OF PRIMARY CIRCUIT SUCH AS CABLE, CONNECTORS AND TRANSFORMERS SHALL BE BROUGHT ABOVE GROUND AT EDGE LIGHTS, SIGNS, REIL, PAPI, ETC.
3. THERE SHALL BE NO EXPOSED POWER/CONTROL CABLES BETWEEN THE POINT WHERE THEY LEAVE THE UNDERGROUND (DEB OR L-867 BASES) AND WHERE THEY ENTER THE EQUIPMENT (SUCH AS TAXIWAY SIGNS, PAPI, REIL, ETC.) ENCLOSURES. THESE CABLES SHALL BE ENCLOSED IN RIGID CONDUIT OR IN FLEXIBLE, WATERTIGHT CONDUIT WITH BREAKABLE COUPLING(S) AT THE GRADE OR THE HOUSING COVER, AS SHOWN IN APPLICABLE DETAILS.
4. THE JOINTS OF THE L-823 PRIMARY CONNECTORS SHALL BE WRAPPED WITH AT LEAST ONE LAYER OF RUBBER OR SYNTHETIC RUBBER TAPE AND ONE LAYER OF PLASTIC TAPE, ONE-HALF LAPPED, EXTENDING AT LEAST 1-1/2 INCHES ON EACH SIDE OF THE JOINT, AS SHOWN ON SHEET NO. 21.
5. THE CABLE ENTRANCE INTO THE FIELD-ATTACHED L-823 CONNECTORS SHALL BE ENCLOSED BY A HEAT-SHRINKABLE TUBING WITH CONTINUOUS INTERNAL ADHESIVE, AS SHOWN ON SHEET NO. 21.
6. L-823 TYPE II, TWO-CONDUCTOR SECONDARY CONNECTORS SHALL BE CLASS 'A' (FACTORY MOLDED).
7. THERE SHALL BE NO SPLICES IN THE SECONDARY CABLE(S) WITHIN THE STEMS OF A RUNWAY/TAXIWAY EDGE/THRESHOLD LIGHTING FIXTURE AND THE WIREWAYS LEADING TO TAXIWAY SIGNS AND PAPI/REIL EQUIPMENT.
8. ELECTRICAL INSULATING GREASE SHALL BE APPLIED WITHIN THE L-823, SECONDARY, TWO CONDUCTOR CONNECTORS TO PREVENT WATER ENTRANCE. THESE CONNECTORS SHALL NOT BE TAPED.
9. DEB ISOLATION TRANSFORMERS SHALL BE BURIED AT A DEPTH OF TEN (10") INCHES ON A LINE CROSSING THE LIGHT AND PERPENDICULAR TO THE RUNWAY/TAXIWAY CENTERLINE AT A LOCATION TWELVE (12") INCHES FROM THE LIGHT OPPOSITE FROM THE RUNWAY/TAXIWAY.
10. A SLACK OF THREE (3') FEET, MINIMUM, SHALL BE PROVIDED IN THE PRIMARY CABLE AT EACH TRANSFORMER/CONNECTOR TERMINATION. AT STAKE-MOUNTED LIGHTS, THE SLACK SHALL BE LOOSELY COILED IMMEDIATELY BELOW THE ISOLATION TRANSFORMER.
11. DIRECTION OF PRIMARY CABLES SHALL BE IDENTIFIED BY COLOR CODING AS FOLLOWS: WHEN FACING LIGHT WITH BACK TO PAVEMENT, CABLE TO THE LEFT IS CODED RED AND CABLE TO RIGHT IS CODED BLUE. THIS APPLIES TO STAKE MOUNTED LIGHTS AND BASE MOUNTED LIGHTS WHERE THE BASE HAS ONLY ONE ENTRANCE.
12. L-867 BASES SHALL BE SIZE B, 24" DEEP, CLASS I, UNLESS OTHERWISE NOTED.
13. BASE MOUNTED BREAKABLE COUPLINGS SHALL NOT HAVE WEEP HOLES TO THE OUTSIDE. PLUGGED UP HOLES SHALL NOT BE ACCEPTABLE. IT SHALL BE A 1/4" DIAMETER, MINIMUM, OR EQUIVALENT OPENING FOR DRAINAGE FROM THE SPACE AROUND THE SECONDARY CONNECTOR INTO THE L-867 BASE.
14. THE ELEVATION OF THE BREAKABLE COUPLING GROOVE SHALL NOT EXCEED 1-1/2" ABOVE THE EDGE OF THE COVER IN CASE OF BASE MOUNTED COUPLINGS, OR THE TOP OF THE STAKE IN CASE OF STAKE MOUNTED COUPLINGS.
15. WHERE THE BREAKABLE COUPLING IS NOT AN INTEGRAL PART OF THE LIGHT FIXTURE STEM OR MOUNTING LEG, A BEAD OF SILICON SEAL SHALL BE APPLIED COMPLETELY AROUND LIGHT STEM OR WIREWAY AT BREAKABLE COUPLING TO PROVIDE A WATERTIGHT SEAL.
16. TOPS OF THE STAKES SUPPORTING LIGHT FIXTURES SHALL BE FLUSH WITH THE SURROUNDING GRADE.
17. PLASTIC LIGHTING FIXTURE COMPONENTS, SUCH AS LAMP HEADS, STEMS, BREAKABLE COUPLINGS, BASE COVERS, BRACKETS, STAKES, SHALL NOT BE ACCEPTABLE.
18. THE TOLERANCE FOR THE HEIGHT OF RUNWAY/TAXIWAY EDGE LIGHTS SHALL BE: ONE (1) INCH. IN CASE OF STAKE MOUNTED LIGHTS, THE SPECIFIED LIGHTING FIXTURE HEIGHT SHALL BE MEASURED BETWEEN THE TOP OF THE STAKE AND THE TOP OF THE LENS. IN CASE OF BASE MOUNTED LIGHTS, THE SPECIFIED LIGHTING FIXTURE HEIGHT SHALL BE MEASURED BETWEEN THE TOP OF THE BASE FLANGE AND THE TOP OF THE LENS, THUS INCLUDING THE BASE COVER, THE FRANGIBLE COUPLING, THE STEM, THE LAMP HOUSING AND THE LENS.

19. THE TOLERANCE FOR THE LATERAL SPACING (LIGHT LANE TO RUNWAY/TAXIWAY CENTERLINE) OF RUNWAY/TAXIWAY EDGE LIGHTS SHALL BE ONE (1) INCH. THIS ALSO APPLIES AT INTERSECTIONS TO LATERAL SPACING BETWEEN LIGHTS OF A RUNWAY/TAXIWAY AND THE INTERSECTING RUNWAY/TAXIWAY.
20. ENTRANCES INTO L-867 BASES SHALL HAVE CONDUIT COUPLINGS OR REDUCERS TO INTERFACE UNIT DUCT/CONDUIT TO L-867 BASE HUBS, OR SHALL BE SEALED WITH HEAT SHRINK AS SHOWN IN DETAIL "B" ON SHEET NO. 21.
21. GALVANIZED/PAINTED EQUIPMENT/COMPONENT SURFACES SHALL NOT BE DAMAGED BY DRILLING, FILING, ETC. DRAIN HOLES IN METAL TRANSFORMER HOUSINGS SHALL BE MADE BEFORE GALVANIZING.
22. EDGE LIGHT NUMBERING TAGS SHALL BE FACING THE PAVEMENT.
23. CABLE/SPLICE/DUCT MARKERS SHALL BE PRECAST CONCRETE OF THE SIZE SHOWN. LETTERS/NUMBERS/ARROWS FOR THE LEGEND TO BE IMPRESSED INTO THE TOPS OF THE MARKERS SHALL BE PRE-ASSEMBLED AND SECURED IN THE MOLD BEFORE THE CONCRETE IS POURED. LEGEND INSCRIBED BY HAND IN WET CONCRETE SHALL NOT BE ACCEPTABLE.
24. ALL UNDERGROUND CABLE RUNS SHALL BE IDENTIFIED BY CABLE MARKERS AT 200 FEET MAXIMUM SPACING, WITH AN ADDITIONAL MARKER AT EACH CHANGE OF DIRECTION OF THE CABLE RUN. CABLE MARKERS SHALL BE INSTALLED IMMEDIATELY ABOVE THE CABLES.
25. THERE SHALL BE NO SPLICES BETWEEN THE ISOLATION TRANSFORMERS. L-823 CONNECTORS ARE ALLOWED AT TRANSFORMER CONNECTIONS ONLY, UNLESS OTHERWISE SHOWN.
26. APPLY AN OXIDE INHIBITING, ANTI-SEIZING COMPOUND TO ALL SCREWS, NUTS AND BREAKAGE COUPLING THREADS.
27. LOCATIONS OF ENDS OF ALL UNDERGROUND DUCTS SHALL BE IDENTIFIED BY DUCT MARKERS.
28. WHERE A PARALLEL, CONSTANT VOLTAGE PAPI SYSTEM IS PROVIDED, THE "T" SPLICES SHALL BE OF THE CAST TYPE.
29. CONCRETE USED FOR SLABS, FOOTINGS, BACKFILL AROUND TRANSFORMER HOUSINGS, MARKINGS, ETC. SHALL BE 3000 PSI, AIR-ENTRAINED.
30. ALL POWER AND CONTROL CABLES IN MAN/HAND HOLES SHALL BE TAGGED. USE EMBOSSED COPPER STRIPS TO BE ATTACHED AT BOTH ENDS TO THE CABLE BY THE USE OF PLASTIC STRAPS. MINIMUM OF TWO TAGS SHALL BE PROVIDED ON EACH CABLE IN A MAN/HAND HOLE-ONE AT THE CABLE ENTRANCE AND ONE AT THE CABLE EXIT.
31. THE LOCATION, SIZE AND TYPE OF MATERIAL OF EXISTING UNDERGROUND UTILITIES INDICATED ON THE PLANS IS NOT REPRESENTED AS BEING ACCURATE, SUFFICIENT OR COMPLETE. IT SHALL BE THE CONTRACTOR'S RESPONSIBILITY TO DETERMINE THE ACTUAL LOCATION OF ALL SUCH FACILITIES, INCLUDING SERVICE CONNECTIONS TO UNDERGROUND UTILITIES. PRIOR TO CONSTRUCTION, THE CONTRACTOR SHALL NOTIFY THE UTILITY COMPANIES OF HIS OPERATIONAL PLANS AND SHALL OBTAIN FROM THE RESPECTIVE UTILITY COMPANIES DETAILED INFORMATION AND ASSISTANCE RELATIVE TO THE LOCATION OF THEIR FACILITIES AND THE WORKING SCHEDULE OF THE COMPANIES FOR REMOVAL OR ADJUSTMENT WHERE REQUIRED. IN THE EVENT AN UNEXPECTED UTILITY INTERFERENCE IS ENCOUNTERED DURING CONSTRUCTION, THE CONTRACTOR SHALL IMMEDIATELY NOTIFY THE UTILITY COMPANY OF JURISDICTION. THE ENGINEER SHALL ALSO BE IMMEDIATELY NOTIFIED. ANY SUCH MAINS AND SERVICES SHALL BE RESTORED TO SERVICE AT ONCE AND PAID FOR BY THE CONTRACTOR AT NO ADDITIONAL COST TO THE CONTRACT. CALL J.U.L.I.E. FOR UTILITY INFORMATION AT 1-800-892-0123. ALSO CONTACT AIRPORT MANAGER AND/OR RESPECTIVE AIRPORT PERSONNEL FOR ASSISTANCE IN LOCATING UNDERGROUND AIRPORT CABLES AND/OR UTILITIES. CONTACT FAA FOR ASSISTANCE IN LOCATING THEIR CABLES.

**GROUNDING NOTES FOR AIRFIELD LIGHTS AND TAXI GUIDANCE SIGNS**

1. GROUNDING FOR RUNWAY LIGHTS, TAXIWAY LIGHTS, AND LIGHTED TAXI GUIDANCE SIGNS SHALL BE AS DETAILED ON THE PLANS AND AS SPECIFIED HEREIN. PER FAA AC 150/5340-30C DESIGN AND INSTALLATION DETAILS FOR AIRPORT VISUAL AIDS, CHAPTER 12, PART 12.6; A SAFETY GROUND MUST BE INSTALLED AT EACH LIGHT FIXTURE. THE PURPOSE OF THE SAFETY GROUND IS TO PROTECT PERSONNEL FROM POSSIBLE CONTACT WITH AN ENERGIZED LIGHT BASE OR MOUNTING STAKE AS THE RESULT OF A SHORTED CABLE OR ISOLATION TRANSFORMER. A SAFETY GROUND SHALL BE INSTALLED AT EACH TRANSFORMER BASE/LIGHT CAN ASSOCIATED WITH RUNWAY LIGHTS, TAXIWAY LIGHTS, AND LIGHTED TAXI GUIDANCE SIGNS. A SAFETY GROUND SHALL ALSO BE INSTALLED AT EACH STAKE MOUNTED LIGHT FIXTURE. THE SAFETY GROUND SHALL BE A #6 AWG BARE COPPER CONDUCTOR CONNECTED TO THE GROUND LUG ON THE RESPECTIVE L-867 TRANSFORMER BASE/LIGHT CAN OR MOUNTING STAKE AND A 5/8-INCH DIAMETER BY 8-FOOT LONG (MINIMUM) UL LISTED COPPER CLAD GROUND ROD. CONNECTIONS TO GROUND LUGS ON THE L-867 TRANSFORMER BASE/LIGHT CAN OR MOUNTING STAKE SHALL BE WITH A UL LISTED GROUNDING CONNECTOR. CONNECTIONS TO GROUND RODS SHALL BE MADE WITH EXOTHERMIC WELD TYPE CONNECTORS, CADWELD BY ERICO PRODUCTS, INC., SOLON, OHIO, (PHONE: 800-248-9353), THERMOWELD BY CONTINENTAL INDUSTRIES, INC., TULSA, OKLAHOMA (PHONE: 918-663-1440) OR ULTRAWELD BY HARGER, GRAYSLAKE, ILLINOIS (PHONE: 800-842-7437). EXOTHERMIC WELD CONNECTIONS SHALL BE INSTALLED IN CONFORMANCE WITH THE RESPECTIVE MANUFACTURER'S DIRECTIONS USING MOLDS AS REQUIRED FOR EACH RESPECTIVE APPLICATION. BOLTED CONNECTIONS WILL NOT BE PERMITTED AT GROUND RODS. TOP OF GROUND RODS SHALL BE BURIED 12 INCHES MINIMUM BELOW GRADE, UNLESS SPECIFIED OTHERWISE HEREIN, FOR RESPECTIVE APPLICATIONS.
2. CLEAN ALL METAL SURFACES BEFORE MAKING GROUND CONNECTIONS. METALLIC SURFACES TO BE JOINED SHALL BE PREPARED BY THE REMOVAL OF ALL NON-CONDUCTIVE MATERIAL PER 2005 NATIONAL ELECTRICAL CODE ARTICLE 250-12.
3. PER FAA 150/5340-30C THE RESISTANCE TO GROUND OF THE RESPECTIVE MOUNTING STAKE OR LIGHT BASE (WITH GROUND ROD CONNECTED) MUST BE 25 OHMS OR LESS.

DATE	REVISION				
<p><b>TRI-TOWNSHIP AIRPORT SAVANNA, CARROLL COUNTY ILLINOIS</b></p> <p style="font-size: small;">IL PROJ.: SFY-3782      A.I.P. PROJ.: 3-17-0091-B14</p>					
Heli. Project No. 07A01440_0800 Filename E-003.DWG Scale NONE Date 05/13/08	LAYOUT DRAWN KNL REVIEWED CAH	01/02/08 01/02/08 02/05/08	 <p style="font-size: x-small;">Hanson Professional Services Inc. 1625 S. Sun Springfield, Illinois 62703-2888 Offices Nationwide</p>		
<p><b>CONSTRUCT NEW VAULT</b></p> <p><b>ELECTRICAL NOTES SHEET 2</b></p>		<p style="font-size: 2em; font-weight: bold;">23</p> <p style="font-size: x-small;">23 of 24 sheets</p>			

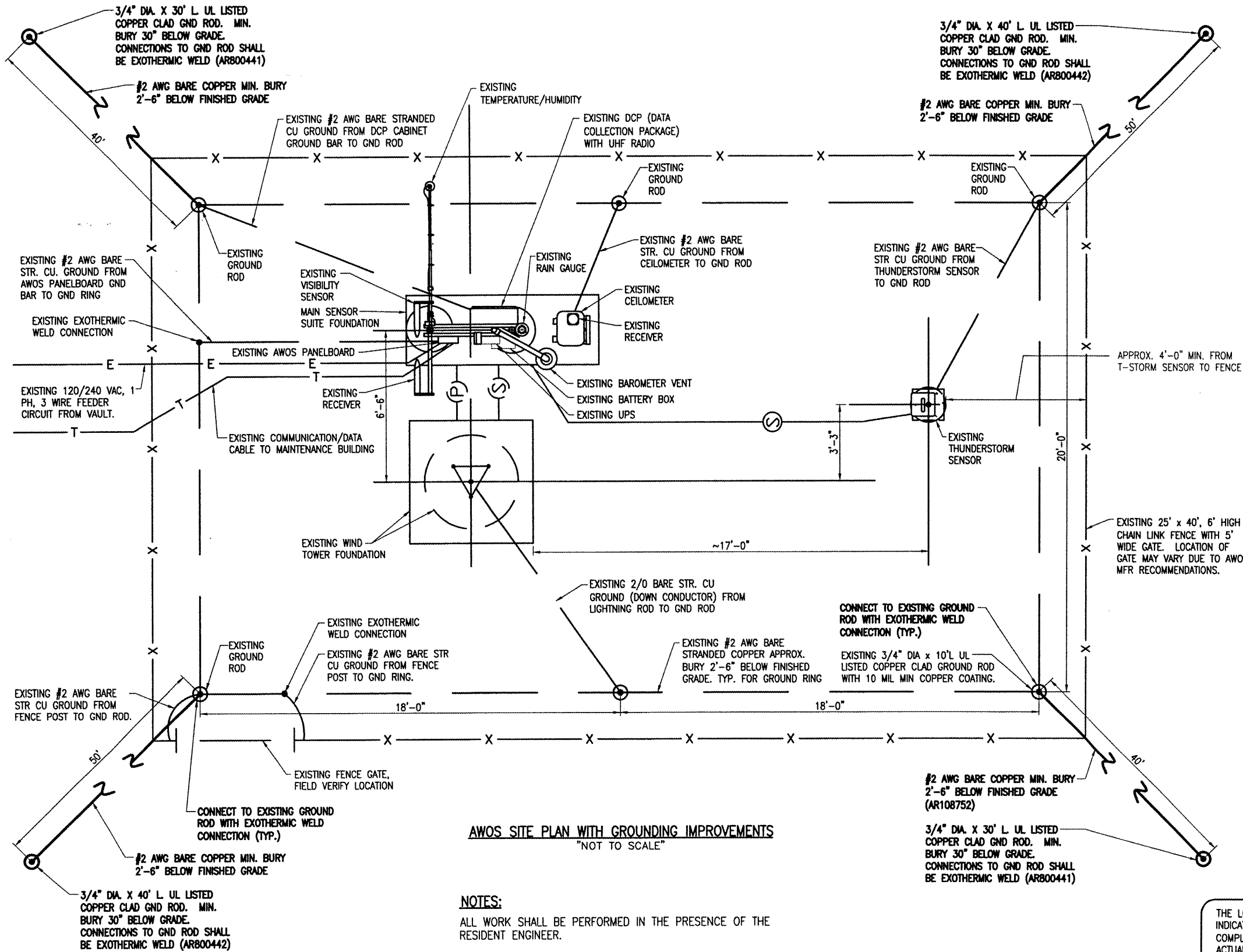

**AWOS SITE PLAN WITH GROUNDING IMPROVEMENTS**  
"NOT TO SCALE"

**NOTES:**  
ALL WORK SHALL BE PERFORMED IN THE PRESENCE OF THE RESIDENT ENGINEER.  
ALL WORK SHALL BE PERFORMED WITH THE AWOS SHUT OFF.  
COORDINATE WORK TO AVOID INTERFERENCES WITH EXISTING FENCE POSTS.

**GROUNDING NOTES:**  
THE EXISTING GROUND RING FOR THE AWOS SHALL BE EXCAVATED AT TWO OF THE RESPECTIVE CORNERS TO LOCATE THE EXISTING CORNER GROUND RODS. A 3/4" DIAMETER BY 30-FOOT GROUND ROD SHALL BE INSTALLED 40 FEET OUTWARD DIAGONALLY FROM THE RESPECTIVE EXISTING CORNER GROUND ROD IN THE GROUND RING. A #2 AWG BARE COPPER LATERAL CONDUCTOR WILL BE CONNECTED TO THE EXISTING GROUND ROD IN THE GROUND RING AND EXTENDED 40 FEET DIAGONALLY OUTWARD FROM THE GROUND RING IN A 30-INCH MINIMUM DEPTH TRENCH AND CONNECTED TO THE 30 FOOT GROUND ROD. AT THE OPPOSITE CORNER OF THE EXISTING GROUND RING FOR THE AWOS A SECOND 3/4" DIAMETER BY 30-FOOT GROUND ROD SHALL BE INSTALLED 40 FEET OUTWARD DIAGONALLY FROM THE RESPECTIVE EXISTING CORNER GROUND ROD IN THE GROUND RING. A #2 AWG BARE COPPER LATERAL CONDUCTOR WILL BE CONNECTED TO THE EXISTING GROUND ROD AND EXTENDED 40 FEET DIAGONALLY OUTWARD FROM THE GROUND RING IN A 30-INCH MINIMUM DEPTH TRENCH AND CONNECTED TO THE 30 FOOT GROUND ROD. AFTER THE TWO LATERALS AND GROUND RODS ARE INSTALLED THE CONTRACTOR SHALL TEST THE AWOS GROUND RING WITH AN INSTRUMENT SPECIFICALLY DESIGNED FOR TESTING GROUND SYSTEMS. GROUND RESISTANCE TEST SHALL BE CONDUCTED IN THE PRESENCE OF THE RESIDENT ENGINEER. TEST RESULTS SHALL BE RECORDED AND PROVIDED TO THE RESIDENT ENGINEER.  
  
IF GROUND RESISTANCE EXCEEDS 10 OHMS, TWO ADDITIONAL GROUND RODS AND LATERAL GROUNDING ELECTRODE CONDUCTORS WILL BE CONNECTED TO THE AWOS GROUND RING AS FOLLOWS:

THE EXISTING GROUND RING FOR THE AWOS SHALL BE EXCAVATED AT THE TWO REMAINING RESPECTIVE CORNERS TO LOCATE THE EXISTING CORNER GROUND RODS. A 3/4" DIAMETER BY 40-FOOT GROUND ROD SHALL BE INSTALLED 50 FEET OUTWARD DIAGONALLY FROM THE RESPECTIVE EXISTING CORNER GROUND ROD IN THE GROUND RING. A #2 AWG BARE COPPER LATERAL CONDUCTOR WILL BE CONNECTED TO THE EXISTING GROUND ROD IN THE GROUND RING AND EXTENDED 50 FEET DIAGONALLY OUTWARD FROM THE GROUND RING IN A 30-INCH MINIMUM DEPTH TRENCH AND CONNECTED TO THE 40 FOOT GROUND ROD. AT THE OPPOSITE CORNER OF THE EXISTING GROUND RING, FOR THE AWOS, A SECOND 3/4" DIAMETER BY 40-FOOT GROUND ROD SHALL BE INSTALLED 50 FEET OUTWARD DIAGONALLY FROM THE RESPECTIVE EXISTING CORNER GROUND ROD IN THE GROUND RING. A #2 AWG BARE COPPER LATERAL CONDUCTOR WILL BE CONNECTED TO THE EXISTING GROUND ROD AND EXTENDED 50 FEET DIAGONALLY OUTWARD FROM THE GROUND RING IN A 30-INCH MINIMUM DEPTH TRENCH AND CONNECTED TO THE 30 FOOT GROUND ROD. AFTER THE TWO ADDITIONAL LATERALS AND GROUND RODS ARE INSTALLED THE CONTRACTOR SHALL TEST THE AWOS GROUND RING WITH AN INSTRUMENT SPECIFICALLY DESIGNED FOR TESTING GROUND SYSTEMS. GROUND RESISTANCE TEST SHALL BE CONDUCTED IN THE PRESENCE OF THE RESIDENT ENGINEER. TEST RESULTS SHALL BE RECORDED AND PROVIDED TO THE RESIDENT ENGINEER.

THE LOCATION, SIZE AND TYPE OF MATERIAL OF EXISTING UNDERGROUND UTILITIES INDICATED ON THE PLANS IS NOT REPRESENTED AS BEING ACCURATE, SUFFICIENT OR COMPLETE. IT SHALL BE THE CONTRACTOR'S RESPONSIBILITY TO DETERMINE THE ACTUAL LOCATION OF ALL SUCH FACILITIES, INCLUDING SERVICE CONNECTIONS TO UNDERGROUND UTILITIES. PRIOR TO CONSTRUCTION, THE CONTRACTOR SHALL NOTIFY THE UTILITY COMPANIES OF HIS OPERATIONAL PLANS AND SHALL OBTAIN FROM THE RESPECTIVE UTILITY COMPANIES DETAILED INFORMATION AND ASSISTANCE RELATIVE TO THE LOCATION OF THEIR FACILITIES AND THE WORKING SCHEDULE OF THE COMPANIES FOR REMOVAL OR ADJUSTMENT WHERE REQUIRED. IN THE EVENT AN UNEXPECTED UTILITY INTERFERENCE IS ENCOUNTERED DURING CONSTRUCTION, THE CONTRACTOR SHALL IMMEDIATELY NOTIFY THE UTILITY COMPANY OF JURISDICTION. THE ENGINEER SHALL ALSO BE IMMEDIATELY NOTIFIED. ANY SUCH MAINS AND SERVICES SHALL BE RESTORED TO SERVICE AT ONCE AND PAID FOR BY THE CONTRACTOR AT NO ADDITIONAL COST TO THE CONTRACT.

CALL J.U.L.I.E. FOR UTILITY INFORMATION AT 1-800-892-0123.

BY	
REVISION	
DATE	

TRI-TOWNSHIP AIRPORT  
SAVANNA, CARROLL COUNTY  
ILLINOIS

HEL Project No. 07A0144D_0800	05/12/08
Filename E-102.DWG	05/12/08
Scale NOT TO SCALE	05/12/08
Date 05/13/08	05/13/2008
LAYOUT	CAH
DRAWN	BAK
REVIEWED	CAH



CONSTRUCT  
NEW VAULT

AWOS  
GROUNDING  
IMPROVEMENTS

MAY 13, 2008 8:34 PM WALLE00723  
I:\AIRPORTS\SAVANNA\07A0144\CAD\SHETS\E-102.DWG - Layout1