

P.A. RTE.	SECTION	COUNTY	TOTAL SHEETS	SHEET NO.
VAR	0	VARIOUS	43	1
FED. ROAD DIST. NO.	ILLINOIS	CONTRACT NO. 66D15		

D-93-006-14

STATE OF ILLINOIS  
DEPARTMENT OF TRANSPORTATION  
DIVISION OF HIGHWAYS

**PROPOSED  
HIGHWAY PLANS**

VARIOUS ROUTES  
D-3 HIGHWAY DAMAGE REPAIR 2015  
VARIOUS COUNTIES

C - 93-106-14

REPAIRING MOTORIST CAUSED DAMAGE TO HIGHWAY FACILITIES

INDEX OF SHEETS

- 1 COVER SHEET
- 2 STANDARDS AND GENERAL NOTES
- 3 - 6 SUMMARY OF QUANTITIES
- 7 REFLECTOR AND TERMINAL MARKER PLACEMENT DETAIL
- 8 HTC CABLE TENSION CHARTS & LOG
- 9 TIMBER CURB & BITUMINOUS CURB REPAIR, GUARD POST DETAIL & IMPACT ATTENUATOR LAYOUT PLAN
- 10 - 12 TUBULAR THRIE BEAM RETROFIT RAIL FOR BRIDGES
- 13 - 14 TRAFFIC BARRIER TERMINAL, TYPE 1
- 15 - 17 TRAFFIC BARRIER TERMINAL, TYPE 3 & 3A
- 18 - 19 TRAFFIC BARRIER TERMINAL, TYPE 4
- 20 TRAFFIC BARRIER TERMINAL, TYPE 8
- 21 TRAFFIC BARRIER TERMINAL, TYPE 9
- 22 TRAFFIC BARRIER TERMINAL, TYPE 12
- 23 - 43 PRE-MGS GUARDRAIL STANDARDS EFFECTIVE APRIL 1, 2006

HIGHWAY STANDARDS

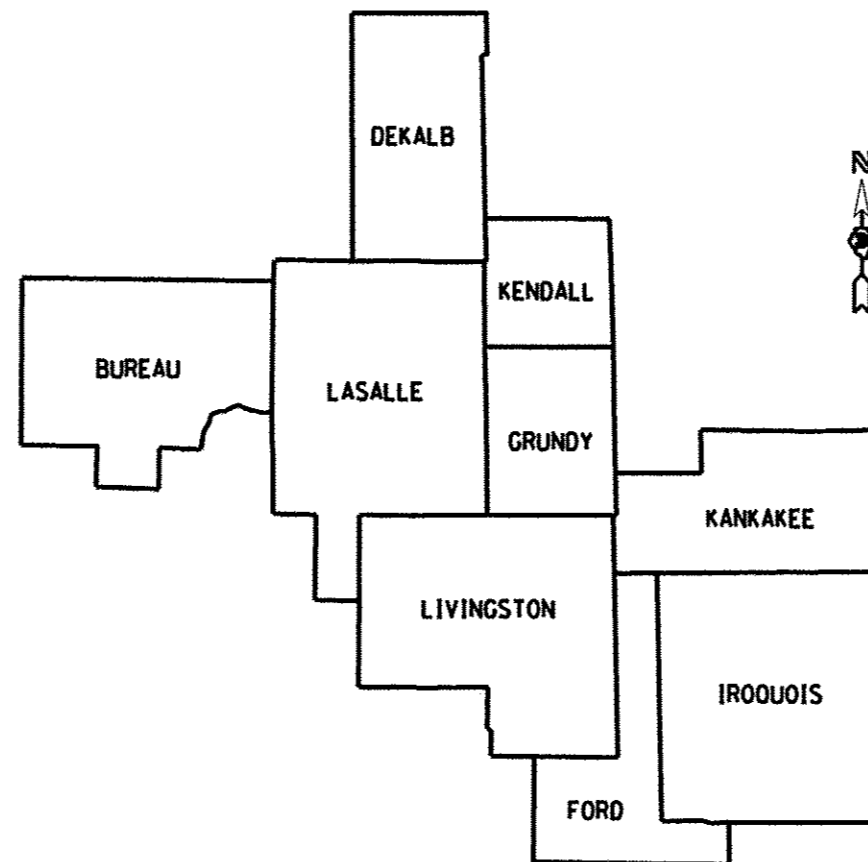
SEE PAGE 2 FOR LIST OF HIGHWAY STANDARDS  
EFFECTIVE JANUARY 1, 2014

MICROFILMED \_\_\_\_\_  
REEL NUMBER \_\_\_\_\_  
AWARDED \_\_\_\_\_  
RESIDENT ENGINEER \_\_\_\_\_  
AS BUILT CHANGES WERE MADE  
ON THE FOLLOWING SHEETS \_\_\_\_\_

J.U.L.I.E.  
JOINT UTILITY LOCATION INFORMATION FOR EXCAVATION  
1-800-892-0123  
OR 811

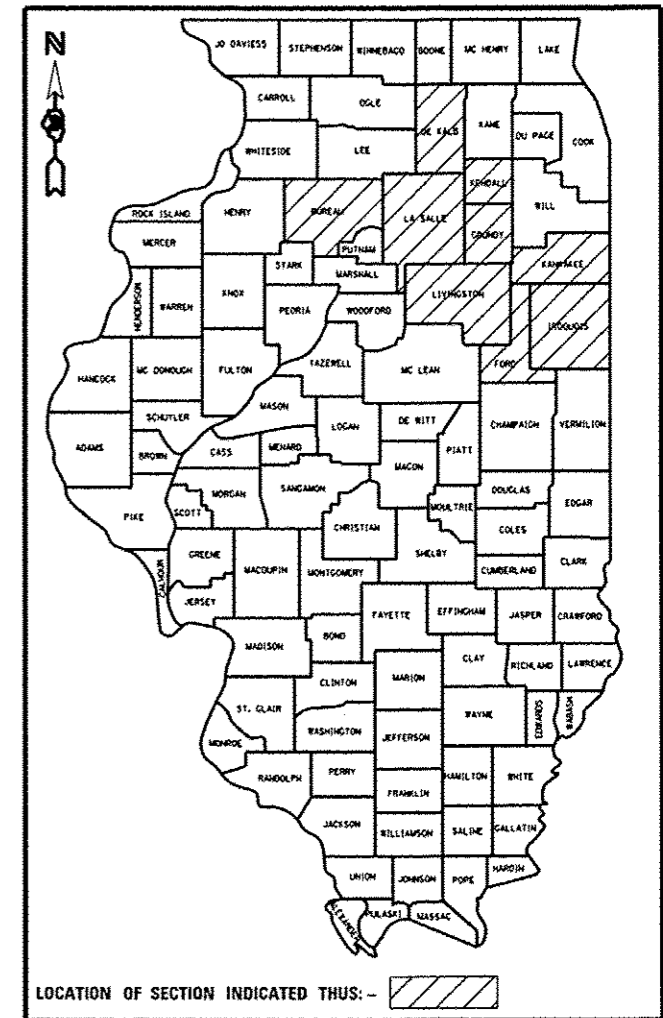
SAFETY AND CLAIMS MANAGER : KRIS FOGARTY  
UNIT CHIEF : PAT BRABOY, P.E.

DISTRICT 3 NO. (815) 434-6131  
CONTRACT NO. 66D15



**DISTRICT 3**

LOCATION MAP  
NOT TO SCALE



LOCATION OF SECTION INDICATED THUS: - [Hatched Box]

STATE OF ILLINOIS  
DEPARTMENT OF TRANSPORTATION  
DIVISION OF HIGHWAYS

SUBMITTED Mar 18 20 14  
Paul White DEPUTY DIRECTOR OF HIGHWAYS, REGION ENGINEER

May 9 20 14  
John D. Baranzelli P.E. ENGINEER OF DESIGN AND ENVIRONMENT

May 9 20 14  
Orin Osman P.E. DIRECTOR OF HIGHWAYS, CHIEF ENGINEER

PRINTED BY THE AUTHORITY  
OF THE STATE OF ILLINOIS

**LIST OF ILLINOIS DOT HIGHWAY STANDARDS**

630001-10	STEEL PLATE BEAM GUARDRAIL
630101-09	GUARDRAIL MOUNTED ON EXISTING CULVERTS
630106-01	LONG-SPAN GUARDRAIL OVER CULVERT
630201-06	PCC/HMA STABILIZATION AT STEEL PLATE BEAM GUARDRAIL
630301-06	SHOULDER WIDENING FOR TYPE 1 (SPECIAL) GUARDRAIL TERMINALS
631011-09	TRAFFIC BARRIER TERMINAL, TYPE 2
631026-05	TRAFFIC BARRIER TERMINAL, TYPE 5
631031-12	TRAFFIC BARRIER TERMINAL, TYPE 6
631032-08	TRAFFIC BARRIER TERMINAL, TYPE 6A
631033-05	TRAFFIC BARRIER TERMINAL, TYPE 6B
631046-04	TRAFFIC BARRIER TERMINAL, TYPE 10
635001-01	DELINEATORS
635006-03	REFLECTOR AND TERMINAL MARKER PLACEMENT
635011-02	REFLECTOR MARKER AND MOUNTING DETAILS
638101-02	CONCRETE CLARE SCREEN
643001-01	SAND MODULE IMPACT ATTENUATORS
664001-02	CHAIN LINK FENCE
665001-02	WOVEN WIRE FENCE
701001-02	OFF-ROAD OPERATIONS 2L, 2W, MORE THAN 15' (4.5 m) AWAY
701006-05	OFF-ROAD OPERATIONS 2L, 2W, 15' (4.5 m) TO 24" (600 mm) FROM PAVEMENT EDGE
701101-04	OFF-ROAD OPERATIONS MULTILANE, 15' (4.5 m) TO 24" (600 mm) FROM PAVEMENT EDGE
701106-02	OFF-ROAD OPERATIONS, MULTILANE, MORE THAN 15' (4.5 m) AWAY
701201-04	LANE CLOSURE, 2L, 2W, DAY ONLY, FOR SPEEDS **e** 45 MPH
701301-04	LANE CLOSURE, 2L, 2W, SHORT TIME OPERATIONS
701400-07	APPROACH TO LANE CLOSURE, FREEWAY/EXPRESSWAY
701406-08	LANE CLOSURE, FREEWAY/EXPRESSWAY, DAY OPERATIONS ONLY
701411-08	LANE CLOSURE, MULTILANE, AT ENTRANCE OR EXIT RAMP FOR SPEEDS **e** 45 MPH
701421-06	LANE CLOSURE, MULTILANE, DAY OPERATIONS ONLY, FOR SPEEDS **e** 45 MPH TO 55 MPH
701426-06	LANE CLOSURE, MULTILANE INTERMITTENT OR MOVING OPERATION, FOR SPEEDS **e** 45 MPH
701456-03	PARTIAL EXIT RAMP CLOSURE FREEWAY/EXPRESSWAY
701501-06	URBAN LANE CLOSURE, 2L, 2W, UNDIVIDED
701502-06	URBAN LANE CLOSURE 2L, 2W, WITH BIDIRECTIONAL LEFT TURN LANE
701601-09	URBAN LANE CLOSURE, MULTILANE, 1W OR 2W WITH NONTRAVERSABLE MEDIAN
701602-07	URBAN LANE CLOSURE, MULTILANE, 2W WITH BIDIRECTIONAL LEFT TURN LANE
701606-09	URBAN LANE CLOSURE, MULTILANE, 2W WITH MOUNTABLE MEDIAN
701701-09	URBAN LANE CLOSURE, MULTILANE INTERSECTION
701801-05	LANE CLOSURE, MULTILANE 1W OR 2W CROSSWALK OR SIDEWALK CLOSURE
701901-03	TRAFFIC CONTROL DEVICES

**GENERAL NOTES**

ANY REFERENCE TO A STANDARD IN THESE PLANS SHALL BE INTERPRETED TO MEAN THE EDITION AS INDICATED BY THE SUBNUMBER SHOWN IN THE LIST OF STANDARDS OR THE COPY INCLUDED IN THESE PLANS.

THE CONTRACTOR IS ADVISED THAT THERE MAYBE PRESENCE OF DEPARTMENT-OWNED UNDERGROUND ELECTRICAL CABLE WITHIN THE LIMITS OF THE PROPOSED IMPROVEMENT. THE CONTRACTOR SHALL REQUEST THE ILLINOIS DEPARTMENT OF TRANSPORTATION IN OTTAWA (815-434-8417) TO LOCATE THE UNDERGROUND FACILITIES, PROVIDING A MINIMUM OF 72 HOURS NOTICE. THE DEPARTMENT IS NOT A MEMBER OF THE JOINT UTILITY LOCATING INFORMATION FOR EXCAVATORS (JULIE) SYSTEM.

ALL DAMAGE TO DEPARTMENT OWNED UNDERGROUND FACILITIES, CAUSED BY THE CONTRACTOR SHALL BE REPAIRED TO THE SATISFACTION OF THE DEPARTMENT AT THE CONTRACTOR'S EXPENSE. THIS SHALL INCLUDE ALL TEMPORARY REPAIRS REQUIRED TO KEEP THE FACILITY OPERATIONAL WHILE MATERIAL IS BEING OBTAINED TO MAKE PERMANENT REPAIRS. SPLICING OF ELECTRIC CABLE SHALL NOT BE ALLOWED. ELECTRIC CABLE SHALL BE REPLACED FROM POLE TO POLE OR CONTROLLER.

THE CONTRACTOR IS REMINDED TO CAREFULLY EXAMINE THIS CONTRACT FOR NEW OR CHANGED CONDITIONS FROM ANY PRVIOUS VERSION HE MAY HAVE EXAMINED.

THE REMOVAL OF DAMAGED GUARDRAIL AND DAMAGED POSTS SHALL NOT BE PAID FOR SEPARATELY BUT SHALL BE CONSIDERED INCLUDED IN THE COST OF THE VARIOUS REPLACEMENT PAY ITEMS.

THE TRAFFIC CONTROL REQUIRED FOR THE REPAIRS OR INSTALLATION OF GUARDRAIL OR FENCE SHALL BE CONSIDERED INCIDENTAL TO THE VARIOUS PAY ITEMS OF WORK, AND SHALL BE IN ACCORDANCE WITH THE TRAFFIC CONTROL STANDARDS INCLUDED HEREIN.

ALL HARDWARE (NUTS, BOLTS, WASHERS, STAPLES, WIRES, TIES, ETC.) REQUIRED FOR THE REPAIRS TO OR INSTALLATION OF GUARDRAIL AND FENCE SHALL BE CONSIDERED INCIDENTAL TO THE VARIOUS PAY ITEMS OF WORK IN THIS CONTRACT.

THE CONTRACTOR SHALL BE RESPONSIBLE FOR PROTECTING UTILITY PROPERTY FROM CONSTRUCTION OPERATIONS AS OUTLINED IN ARTICLE 107.31 OF THE STANDARD SPECIFICATIONS. THE J.U.L.I.E. NUMBER IS 1-800-892-0123. A MINIMUM OF 48 HOURS ADVANCE NOTICE IS REQUIRED.

**HIGH TENSION CABLE BARRIER SYSTEM REPAIR SCHEDULE**

LOCATION / COUNTY / SYSTEM	SYSTEM TYPE	REPAIR	REPLACE	HTC SYSTEM	REMOVE &	REMOVE &	F&I HTC	FURNISH & DRIVE
		HTC	HTC	MAINTENANCE	REPLACE	REPLACE	FOUNDATION	METAL SOCKET
			END SECTION		HTC POST	HTC POST (HD)	& POST	with POST
I-55, MP 227-233 / GRUNDY / BRIFEN	SOCKETED	1	2	3	4		6	7
I-55, MP 227-216 / GRUDY & LIVINGSTON / GIBLALTAR	DRIVEN	1	2	3	4			
I-57, MP 324-316 / KANKAKEE / GIBLALTAR	DRIVEN	1	2	3	4			
I-57, MP 292-277 / IROUOUIIS / NUCOR	DRIVEN	1	2	3	4			
I-80, MP 105-97 / LASALLE & GRUNDY / TRINITY	DRIVEN ( HD )	1	2	3		5		
I-80, MP 92-81 / LASALLE / TRINITY	DRIVEN ( HD )	1	2	3		5		

TABLE SHOWS EACH SYSTEM AND IT'S CORRESPONDING PAY ITEMS

**REPAIR PAY ITEMS**

- 1 = REPAIR HIGH TENSION CABLE
- 2 = REPLACE HIGH TENSION CABLE END SECTION
- 3 = HIGH TENSION CABLE SYSTEM MAINTENANCE
- 4 = REMOVE AND REPLACE HIGH TENSION CABLE POST
- 5 = REMOVE AND REPLACE HIGH TENSION CABLE POST (HEAVY DUTY)
- 6 = FURNISH AND INSTALL HIGH TENSION CABLE FOUNDATION AND POST
- 7 = FURNISH AND DRIVE METAL SOCKET WITH POST

STATE OF ILLINOIS  
DEPARTMENT OF TRANSPORTATION  
DISTRICT THREE

PREPARED BY: *Don Brown*  
DISTRICT STUDIES & PLANS ENGINEER

DATE: 3-18-14

EXAMINED BY: *Herb Jung*  
DISTRICT CONSTRUCTION ENGINEER

*Carrie Phillips*  
DISTRICT MATERIALS ENGINEER

*Steve G. Buckner*  
DISTRICT OPERATIONS ENGINEER

• 0-3 HIGHWAY DAMAGE REPAIR 2015

FILE NAME *	USER NAME * #USER#	DESIGNED -	REVISED -	STATE OF ILLINOIS DEPARTMENT OF TRANSPORTATION	GENERAL NOTES		F.A. RTE.	SECTION	COUNTY	TOTAL SHEETS	SHEET NO.	
#FILE#		DRAWN -	REVISED -		SCALE: _____	SHEET NO. _____ OF _____ SHEETS	STA. _____ TO STA. _____	VAR.		VAR.	x	2
	PLOT SCALE * #SCALE#	CHECKED -	REVISED -									CONTRACT NO. 66015
	PLOT DATE * #DATE#	DATE -	REVISED -					FED. ROAD DIST. NO.	ILLINOIS	FED. AID PROJECT		

07M0 07E0 07A0

CODE NO.	ITEM	UNIT	TOTAL QUANTITY	CONSTRUCTION CODE		
				MCHD	CONSTR. MAINT.	HTC BARRIER
				100% MCHD SAFETY	100% STATE SAFETY	100% STATE SAFETY
				0021	0021	0021
				07MOA.01	07EO.01	07AO.02
63100045	TRAFFIC BARRIER TERMINAL, TYPE 2	EACH	2	2	0	0
63100070	TRAFFIC BARRIER TERMINAL, TYPE 5	EACH	1	1	0	0
63100085	TRAFFIC BARRIER TERMINAL, TYPE 6	EACH	1	1	0	0
63100087	TRAFFIC BARRIER TERMINAL, TYPE 6A	EACH	1	1	0	0
63100089	TRAFFIC BARRIER TERMINAL, TYPE 6B	EACH	1	1	0	0
63100095	TRAFFIC BARRIER TERMINAL, TYPE 8	EACH	1	1	0	0
63100101	TRAFFIC BARRIER TERMINAL, TYPE 9	EACH	1	1	0	0
63100105	TRAFFIC BARRIER TERMINAL, TYPE 10	EACH	1	1	0	0
63100115	TRAFFIC BARRIER TERMINAL, TYPE 12	EACH	1	1	0	0
63100167	TRAFFIC BARRIER TERMINAL, TYPE 1 (SPECIAL) TANGENT	EACH	35	20	15	0
63100169	TRAFFIC BARRIER TERMINAL, TYPE 1 (SPECIAL) FLARED	EACH	4	2	2	0
63301210	REMOVE AND REERECT STEEL PLATE BEAM GUARDRAIL, TYPE A	FOOT	150	0	150	0
63301215	REMOVE AND REERECT STEEL PLATE BEAM GUARDRAIL, TYPE B	FOOT	50	0	50	0
63400105	GUARD POSTS	EACH	100	50	50	0

14

• D-5 HIGHWAY DAMAGE REPAIR 2015

FILE NAME *	USER NAME * #USER#	DESIGNED - _____	REVISED - _____	STATE OF ILLINOIS DEPARTMENT OF TRANSPORTATION	SUMMARY OF QUANTITIES			F.A. RTE.	SECTION	COUNTY	TOTAL SHEETS	SHEET NO.
#FILE#		DRAWN - _____	REVISED - _____					VAR.			43	3
#MODELNAME#		CHECKED - _____	REVISED - _____		SCALE: _____	SHEET _____ OF _____ SHEETS	STA. _____ TO STA. _____	CONTRACT NO. 66015		ILLINOIS FED. AID PROJECT		
		DATE - _____	REVISED - _____									

CODE NO.	ITEM	UNIT	TOTAL QUANTITY	CONSTRUCTION CODE		
				MCHD	CONSTR. MAINT.	HTC BARRIER
				100% MCHD SAFETY 0021	100% STATE SAFETY 0021	100% STATE SAFETY 0021
				07MOA.01	07AO.01	07AO.02
64300260	IMPACT ATTENUATORS (FULLY REDIRECTIVE, NARROW), TEST LEVEL 3	EACH	2	1	1	0
66400105	CHAIN LINK FENCE, 4'	FOOT	300	150	150	0
66400305	CHAIN LINK FENCE, 6'	FOOT	350	200	150	0
66500105	WOVEN WIRE FENCE, 4'	FOOT	10000	5000	5000	0
67100100	MOBILIZATION	L SUM	1	0.5	0.5	0
78200410	GUARDRAIL MARKERS, TYPE A	EACH	225	125	100	0
X0321563	REPAIR TRAFFIC BARRIER TERMINAL TYPE 1 SPECIAL	EACH	30	10	20	0
X0322878	TIMBER CURB	FOOT	32	32	0	0
X0326126	WOOD TERMINAL POST	EACH	1	1	0	0
X0327278	REPAIR HIGH TENSION CABLE	FOOT	2300	1800	0	500
X0327279	REPLACE HIGH TENSION CABLE END SECTION	EACH	3	1	0	2
X0327281	REMOVE AND REPLACE HIGH TENSION CABLE POST	EACH	1100	600	0	500
X0327282	REMOVE AND REPLACE HTC POST (HEAVY DUTY)	EACH	150	50	0	100
X6300215	RAIL ELEMENT PLATES	EACH	560	320	240	0

- 0-3 HIGHWAY DAMAGE REPAIR 2015

FILE NAME *	USER NAME * #USER*	DESIGNED - _____	REVISED - _____	STATE OF ILLINOIS DEPARTMENT OF TRANSPORTATION	SUMMARY OF QUANTITIES			F.A. -	SECTION	COUNTY	TOTAL SHEETS	SHEET NO.
#FILE#		DRAWN - _____	REVISED - _____					VAR.			VARIES	43
#MODELNAME*	PLOT SCALE * #SCALE*	CHECKED - _____	REVISED - _____		SCALE: _____	SHEET	OF	SHEETS	STA.	TO STA.	CONTRACT NO. 66015	
	PLOT DATE * #DATE*	DATE - _____	REVISED - _____		ILLINOIS FED. AID PROJECT							

CODE NO.	ITEM	UNIT	TOTAL QUANTITY	CONSTRUCTION CODE		
				MCHD	CONSTR. MAINT.	HTC BARRIER
				100% MCHD SAFETY	100% STATE SAFETY	100% STATE SAFETY
				0021	0021	0021
				07MOA.01	07AO.01	07AO.02
X6300230	STEEL POSTS	EACH	600	300	300	0
X6331101	TUBULAR THRIE BEAM	FOOT	150	100	50	0
X6331105	STEEL POSTS, MODIFIED	EACH	5	5	0	0
X6331110	STEEL POSTS, SPECIAL	EACH	50	0	50	0
X6380207	GLARE SCREEN REPAIR	EACH	20	0	20	0
X6432110	REPLACE IMPACT ATTENUATORS (NON-REDIRECTIVE), TEST LEVEL 3	EACH	190	150	40	0
X6610200	HOT-MIX ASPHALT CURB REPAIR	FOOT	100	100	0	0
X6640502	CHAIN LINK FENCE POST	EACH	21	15	6	0
Z0008760	EMERGENCY WORK CALL OUT	EACH	170	70	50	50
Z0012752	CONCRETE STRUCTURE REPAIR	CU FT	15	15	0	0
Z0020210	PULL POST ARRANGEMENT	EACH	25	10	15	0
Z0026305	FURNISHING AND MAINTAINING AUTOMOTIVE VEHICLES	CAL MO	12	12	0	0
Z0029657	HIGH TENSION CABLE SYSTEM MAINTENANCE	EACH	1400	600	0	800
Z0029659	FURNISH AND INSTALL HIGH TENSION CABLEFOUNDATION AND POST	EACH	45	20	0	25

14

• 0-3 HIGHWAY DAMAGE REPAIR 2015

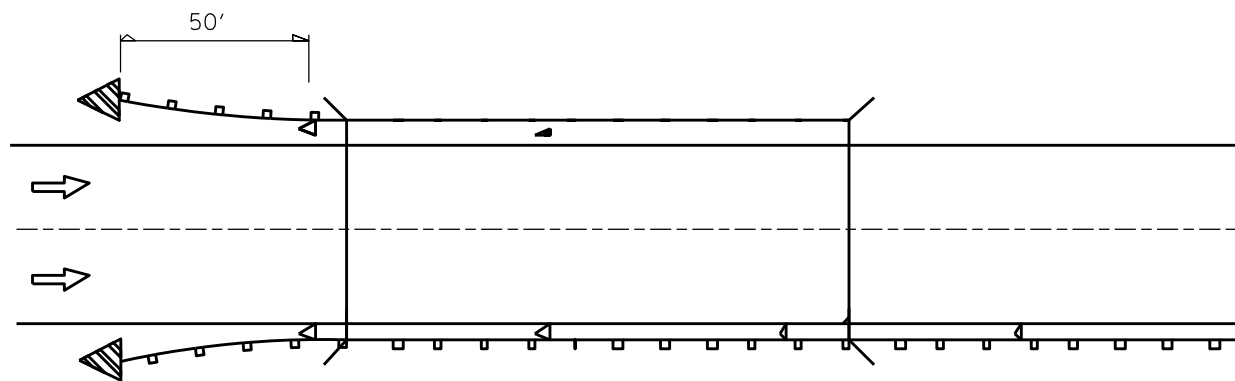
FILE NAME *	USER NAME * #USER*	DESIGNED - _____	REVISED - _____	STATE OF ILLINOIS DEPARTMENT OF TRANSPORTATION	SUMMARY OF QUANTITIES			F.A. RTE.	SECTION	COUNTY	TOTAL SHEETS	SHEET NO.	
#FILE#		DRAWN - _____	REVISED - _____					VAR.			VARIES	43	5
#MODELNAME*		CHECKED - _____	REVISED - _____		SCALE: _____	SHEET _____	OF _____	SHEETS	STA. _____	TO STA. _____	CONTRACT NO. 66015		
		DATE - _____	REVISED - _____		ILLINOIS FED. AID PROJECT								

2105 4 10 AM

CODE NO.	ITEM	UNIT	TOTAL QUANTITY	CONSTRUCTION CODE		
				MCHD	CONSTR. MAINT.	HTC BARRIER
				100% MCHD SAFETY	100% STATE SAFETY	100% STATE SAFETY
				0021	0021	0021
				07MOA. 01	07AO. 01	07AO. 02
Z0029660	FURNISH AND DRIVE METAL SOCKET WITH POST	EACH	20	10	0	10
Z0029665	REPAIR TRAFFIC BARRIER TERMINAL TYPE 1 SPECIAL - RAIL ELEMENT	FOOT	500	0	100	400
Z0052400	REPAIR TRAFFIC BARRIER TERMINAL, TYPE 1	EACH	2	1	1	0
Z0052600	REPAIR TRAFFIC BARRIER TERMINAL, TYPE 2	EACH	1	1	0	0
Z0052700	REPAIR TRAFFIC BARRIER TERMINAL, TYPE 3	EACH	1	1	0	0
Z0052800	REPAIR TRAFFIC BARRIER TERMINAL, TYPE 3A	EACH	1	1	0	0
Z0052900	REPAIR TRAFFIC BARRIER TERMINAL, TYPE 4	EACH	1	1	0	0
Z0053000	REPAIR TRAFFIC BARRIER TERMINAL, TYPE 5	EACH	1	1	0	0
Z0053200	REPAIR TRAFFIC BARRIER TERMINAL, TYPE 6	EACH	2	2	0	0
Z0053210	REPAIR TRAFFIC BARRIER TERMINAL, TYPE 6A	EACH	2	2	0	0
Z0053220	REPAIR TRAFFIC BARRIER TERMINAL, TYPE 6B	EACH	2	2	0	0
Z0053400	REPAIR TRAFFIC BARRIER TERMINAL, TYPE 8	EACH	1	1	0	0
Z0053500	REPAIR TRAFFIC BARRIER TERMINAL, TYPE 9	EACH	1	1	0	0
Z0053575	REPAIR TRAFFIC BARRIER TERMINAL, TYPE 12	EACH	1	1	0	0

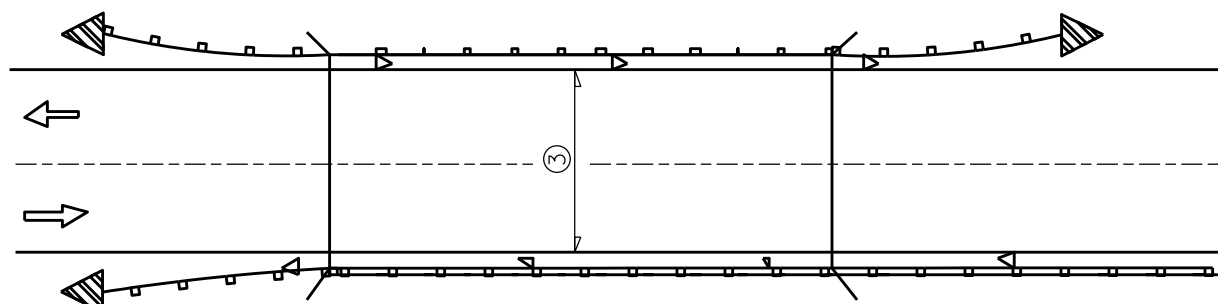
FILE NAME *	USER NAME * #USER*	DESIGNED - _____	REVISED - _____	STATE OF ILLINOIS DEPARTMENT OF TRANSPORTATION	SUMMARY OF QUANTITIES		SCALE: _____	SHEET _____ OF _____ SHEETS	STA. _____ TO STA. _____	CONTRACT NO. 66015	
#FILE#	PLOT SCALE * #SCALE*	DRAWN - _____	REVISED - _____							ILLINOIS FED. AID PROJECT	
#MODELNAME#	PLOT DATE * #DATE*	CHECKED - _____	REVISED - _____		TOTAL SHEETS 43		SHEET NO. 6				
		DATE - _____	REVISED - _____								

D-3 HIGHWAY DAMAGE REPAIR 2015



Reflectors are not to be placed on Terminal End Sections.  
(min. 3 reflectors regardless of length).  
After 400 ft transition, match existing delineator spacing.

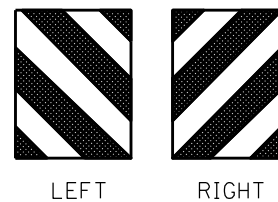
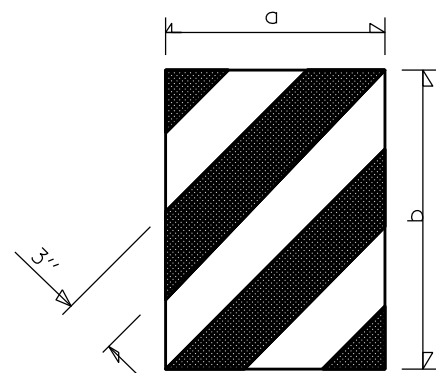
**ONE-WAY TRAFFIC**



③ Bidirectional silver/silver should be used in lieu of monodirectional silver on both sides of two-lane bridges where the pavement is less than 24" wider than the pavement approaching the bridge.

**TWO-WAY TRAFFIC**

- ◁ Monodirectional silver
- ◀ Monodirectional amber
- ▴ Terminal Marker - Black/Yellow  
Left or Right as appropriate



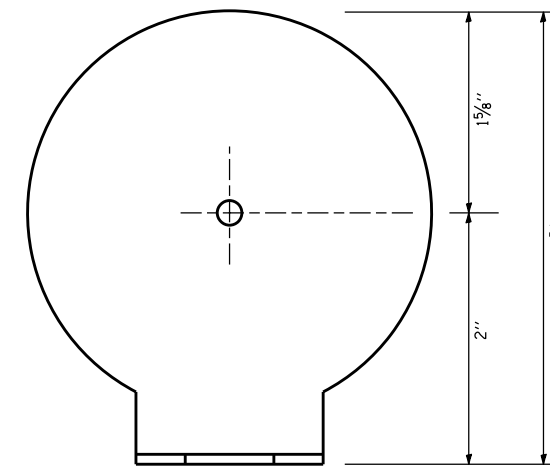
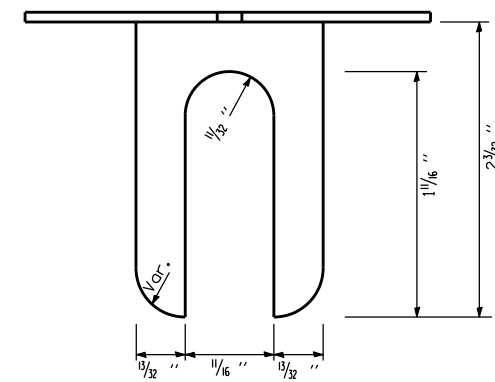
DIMENSION	CASE I	CASE II
a	*	450 (18)
b	*	406 (16)

\* The width and height (a, b) of the terminal marker shall be within approximately 25 mm (1 inch) of the outer edge of the terminal end, with a minimum reflective area of 0.18 m<sup>2</sup> (288 sq. in.)

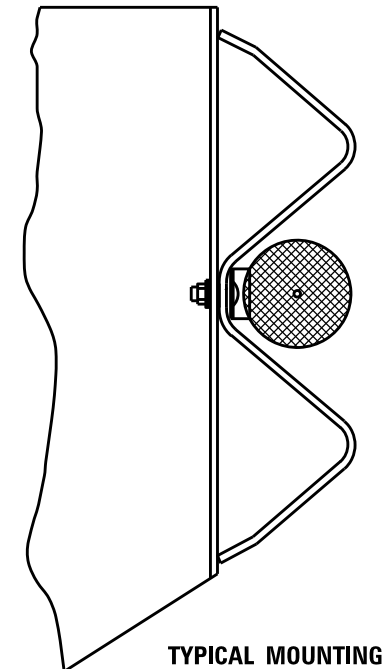
**TERMINAL MARKER DETAILS**

Color: Black / Yellow reflectorized

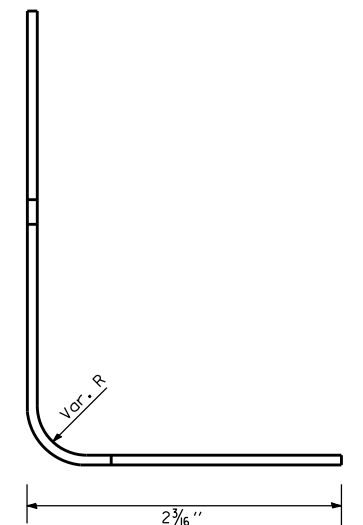
**REFLECTOR AND TERMINAL MARKER PLACEMENT**



**REFLECTOR MARKER TYPE A**



**TYPICAL MOUNTING WITH REFLECTOR**



**NOTES:**

1. BRACKET IS TO BE FABRICATED FROM 12 GA. (MIN) STEEL GALVANIZED IN ACCORDANCE WITH AASHTO M III.
2. MIN. 3 REFLECTORS PER SIDE.
3. BRACKET "FOOT" SHALL BE PLACED BETWEEN THE BOLT HEAD AND THE PLATE WASHER (IF PRESENT).
4. ON THRIE BEAM RAIL, THE BRACKETS SHALL BE ATTACHED TO THE UPPER SPLICE BOLTS.
5. USE CRYSTAL COLOR, BI-DIRECTIONAL REFLECTORS USE AMBER (LEFT) AND CRYSTAL (RIGHT), MONODIRECTIONAL REFLECTORS ON INTERSTATES
6. ALL DIMENSIONS SHOWN ARE MINIMUM

**REFLECTOR DETAIL**

TRINITY CABLE TENSIONS		
TEMPERATURE	PRE-STRETCHED CABLE TENSION	STANDARD CABLE TENSION
°F	LBS	LBS
-15	7500	8800
-10	7300	8600
-5	7100	8400
0	7000	8200
5	6800	8000
10	6600	7800
15	6500	7600
20	6300	7400
25	6100	7200
30	6000	7000
35	5800	6800
40	5600	6600
45	5500	6400
50	5300	6200
55	5100	6000
60	5000	5800
65	4800	5600
70	4600	5400
75	4500	5200
80	4300	5000
85	4100	4800
90	4000	4600
95	3800	4400
100	3600	4200
105	3500	4000
110	3300	3800

TOLERANCE: -200 TO +800 POUNDS

NUCOR CABLE TENSION		
CABLE TEMPERATURE	INITIAL TENSION	EXPECTED TENSION
°F	W/15%	
-30	13706	11918
-20	12979	11286
-10	12252	10654
0	11525	10022
10	10800	9391
20	10073	8759
30	9346	8127
40	8619	7495
50	7894	6864
60	7167	6232
70	6440	5600
80	6077	5284
90	5713	4968
100	5350	4652
110	4986	4336
120	4624	4021

**TENSION CHECK REQUIREMENTS**

CHECKING AND CORRECTING THE TENSION IN EACH CABLE SHALL BE PERFORMED EACH TIME A CABLE IS SPICED AND HTC SYSTEM MAINTENANCE IS SPECIFIED. THE RECOMMENDED TENSIONS FOR EACH SYSTEM ARE SHOWN IN THE CHARTS. THE RESULT OF EACH CHECK SHALL BE RECORDED ON A COPY OF THE TENSION LOG SHEET SHOWN ON THIS SHEET. THE COMPLETED LOG SHALL BE SUBMITTED TO THE SAFETY AND CLAIMS MANAGER.

GIBRALTAR CABLE TENSIONS	
CABLE TEMPERATURE	CABLE TENSION
°F	LBS
-30	
-20	
-10	8000
0	7600
10	7200
20	6800
30	6400
40	6000
50	5600
60	5200
70	4800
80	4400
90	4000
100	3600
110	3200

BRIFEN CABLE TENSIONS	
ROPE TEMPERATURE	TENSION
F°	LBS
0	7300
8	7000
16	6700
24	6400
32	6100
40	5800
48	5500
56	5200
64	4800
72	4500
76	4400
80	4200
88	3900
96	3600
100	3500
104	3300
108	3200
112	3000



Illinois Department of Transportation

TENSION LOG SHEET  
FOR  
High Tension Cable Barrier

System	
Brifen	
USHTCS (Nucor)	
Gibraltar	
Trinity (CASS)	

Date / Time: \_\_\_\_\_  
 Contract / Work Order No. \_\_\_\_\_  
 County: \_\_\_\_\_  
 Route: \_\_\_\_\_  
 Milepost/ GPS: \_\_\_\_\_

Ambient Temp: \_\_\_\_\_  
 Rope Temp: \_\_\_\_\_

3 or 4 Cable System	Location 1 Actual Load kN/LB	Location 2 Actual Load kN/LB	Location 3 Actual Load kN/LB	Average Load (L1+L2+L3/3) kN/LB	Design Load kN/LB (see charts)
Top Cable					
Cable 2					
Cable 3 (If Applicable)					
Bottom Cable					

Note: Readings should be taken at 3 separate places along each cable, moving the tension meter at least 4" between readings. The average load is compared to design load for tolerance.

Number of splices made to the cable: \_\_\_\_\_

Were tensioning adjustments made to the cable: \_\_\_\_\_

Is 1" (minimum) of thread exposed in all turnbuckle windows: \_\_\_\_\_

Splice Type & Location (s): \_\_\_\_\_

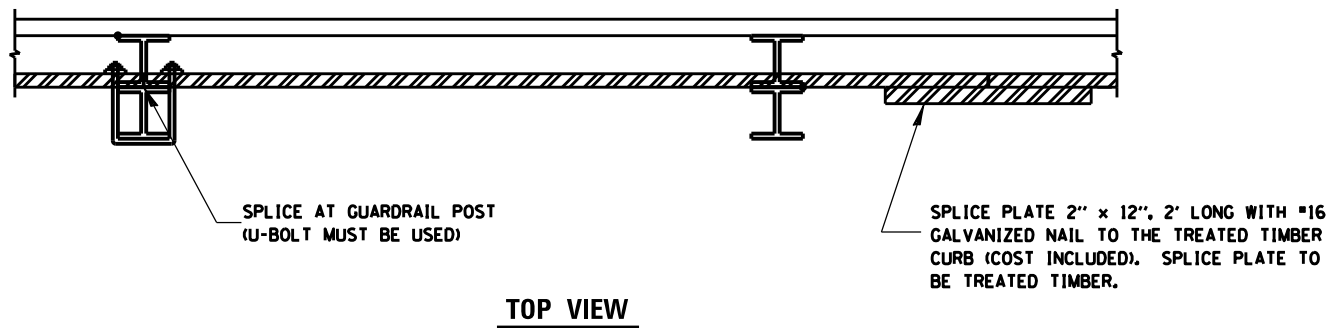
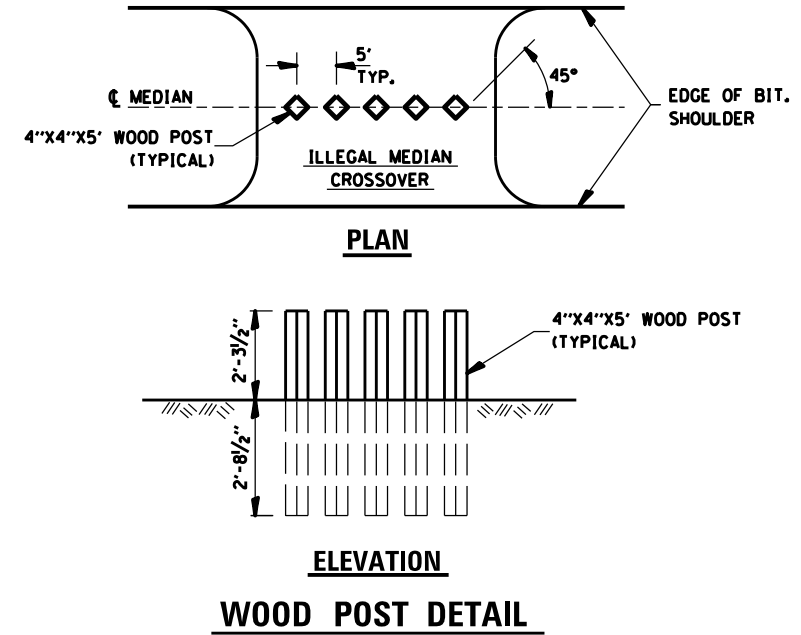
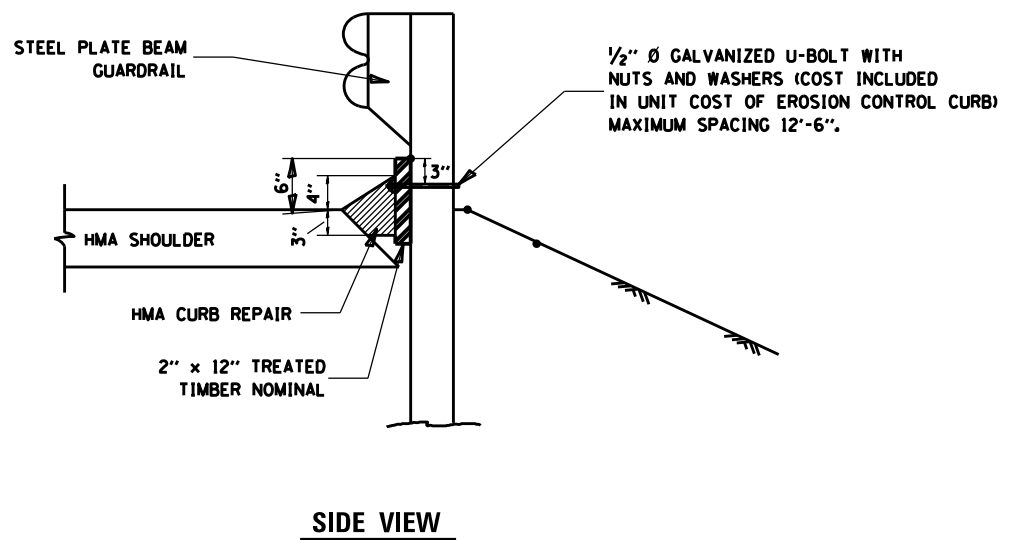
Testing Equipment Used: \_\_\_\_\_

Printed Name & Signature of Tester: \_\_\_\_\_

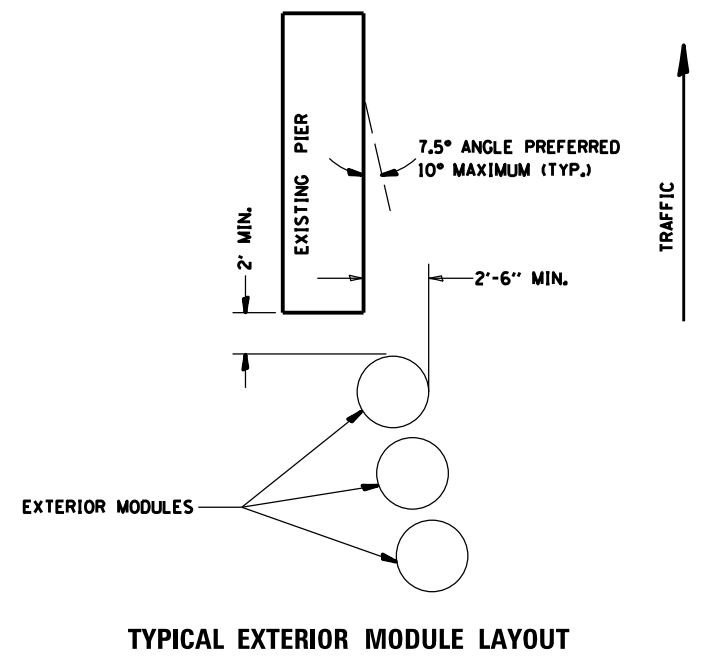
Other Notes: \_\_\_\_\_

IDOT Inspector Initials (if Present): \_\_\_\_\_





**IMPACT ATTENUATOR LAYOUT PLAN**



- NOTES:**
1. THE PAY ITEM "REPLACE IMPACT ATTENUATORS, (NON-REDIRECTIVE), TEST LEVEL 3" HAS BEEN INCLUDED TO REPLACE INDIVIDUAL DAMAGED SAND MODULES.
  2. REPLACEMENT MODULES SHALL MATCH THE KIND OF MODULES THAT ARE REMAINING.
  3. IMPACT ATTENUATORS SHALL BE IN ACCORDANCE WITH SECTION 643 FOR IMPACT ATTENUATORS.
  4. THIS SHEET SHOWS THE LAYOUT INFORMATION FOR REPLACEMENT OF SAND MODULES (IMPACT ATTENUATORS) AT A TYPICAL INTERSTATE LOCATION.
  5. ADJACENT SAND MODULE IMPACT ATTENUATORS THAT ARE NOT DAMAGED, BUT HAVE BEEN SHIFTED LATERALLY FROM THEIR ORIGINAL POSITION SHALL BE REALIGNED OR MOVED BACK TO THEIR ORIGINAL POSITION, AS DIRECTED BY THE ENGINEER. REALIGNMENT OR MOVING OF ADJACENT UNDAMAGED MODULES SHALL NOT BE PAID FOR SEPARATELY BUT SHALL BE CONSIDERED INCLUDED IN THE COST OF REPLACEMENT. THE WORK TO REALIGN OR SHIFT UP TO 2 MODULES SHALL BE INCLUDED WITH EACH REPLACED SAND MODULE IMPACT ATTENUATOR.

**NOTE:**  
THE TREATED TIMBER SHALL BUTT TOGETHER AT THE GUARDRAIL POST OR SPLICED AS SHOWN ON THE DETAIL.

THE TREATED TIMBER SHALL BE TREATED IN ACCORDANCE TO ARTICLE 1007.12 AND ALL PRESERVATIVES SPECIFIED IN THE ARTICLE WILL BE ALLOWED.

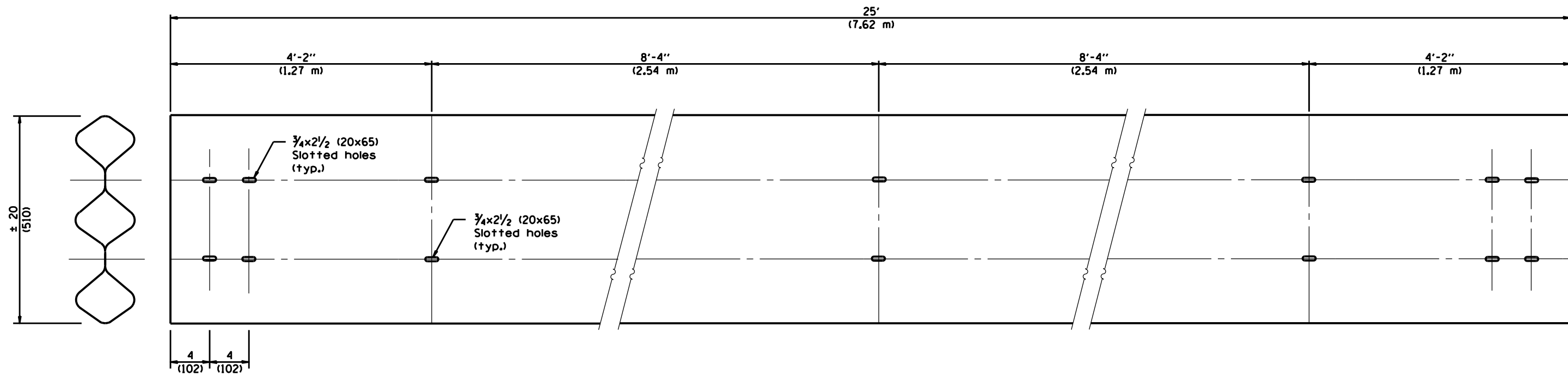
THE PRICE FOR EROSION CONTROL CURB SHALL INCLUDE THE U-BOLTS ATTACHING THE TREATED TIMBER TO THE GUARDRAIL POSTS, TREATED TIMBER, AND THE NECESSARY GRADING TO COMPLETE THIS WORK.

HMA CURB REPAIR SHALL BE MEASURED AND PAID FOR AT CONTRACT UNIT PRICE PER TON.

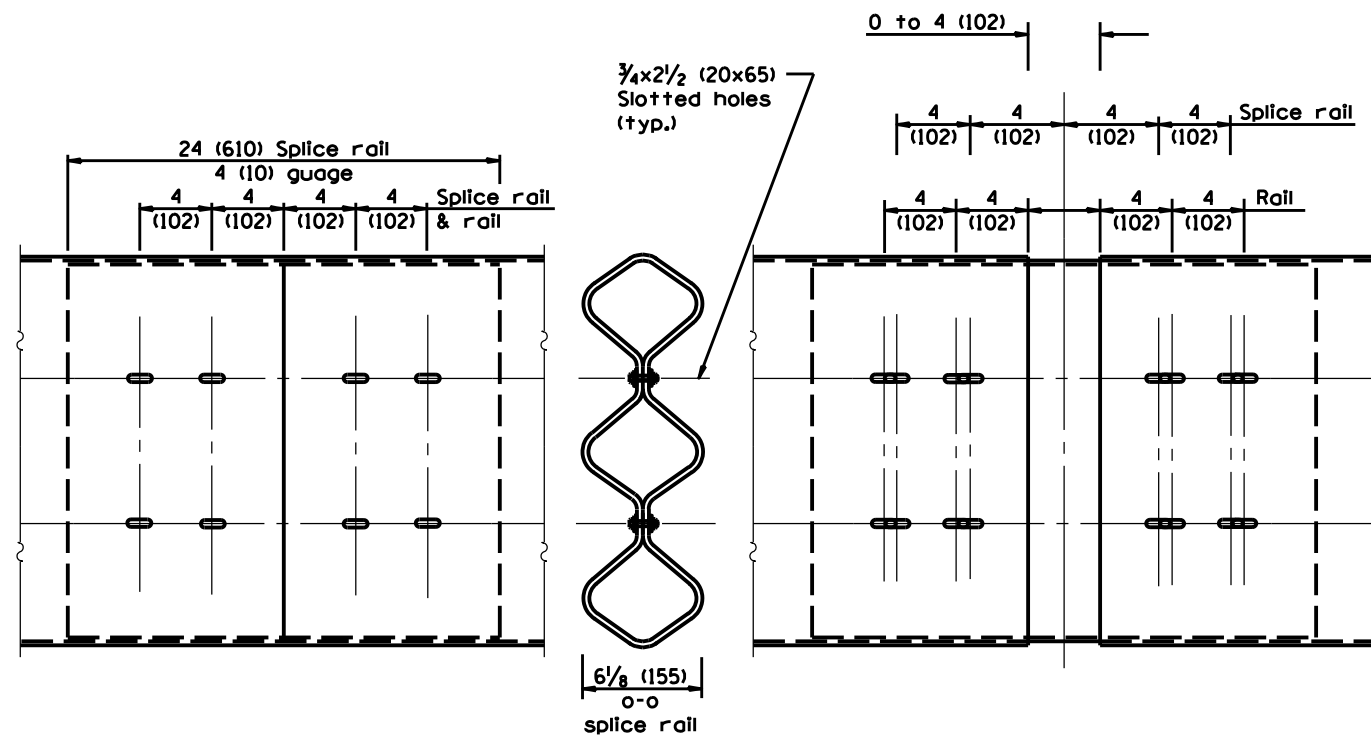
HMA CURB REPAIR SHALL BE IN ACCORDANCE WITH SECTION 408 OF THE STANDARD SPECIFICATIONS.

**TIMBER CURB & HMA CURB REPAIR**

FILE NAME =	USER NAME = *USER*	DESIGNED -	REVISED -	STATE OF ILLINOIS DEPARTMENT OF TRANSPORTATION	TIMBER CURB & BITUMINOUS CURB REPAIR & GUARD POST DETAIL & IMPACT ATTENUATOR PLAN	F.A. RTE.	SECTION	COUNTY	TOTAL SHEETS	SHEET NO.	
*FILEL*		DRAWN -	REVISED -			VAR.		VAR.	43	9	
	PLOT SCALE = *SCALE*	CHECKED -	REVISED -			CONTRACT NO. 66015					
	PLOT DATE = *DATE*	DATE -	REVISED -			FED. ROAD DIST. NO. ILLINOIS FED. AID PROJECT					
					SCALE: _____	SHEET NO. _____ OF _____ SHEETS	STA. _____ TO STA. _____				

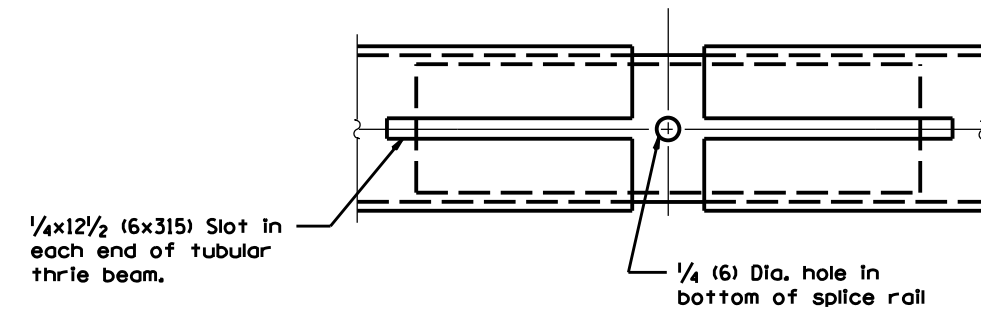


**TUBULAR THRIE BEAM FOR INTERNAL SPLICE JOINT**



**INTERNAL SPLICE JOINT**

**INTERNAL EXPANSION SPLICE JOINT**



**BOTTOM VIEW OF INTERNAL EXPANSION SPLICE JOINT**

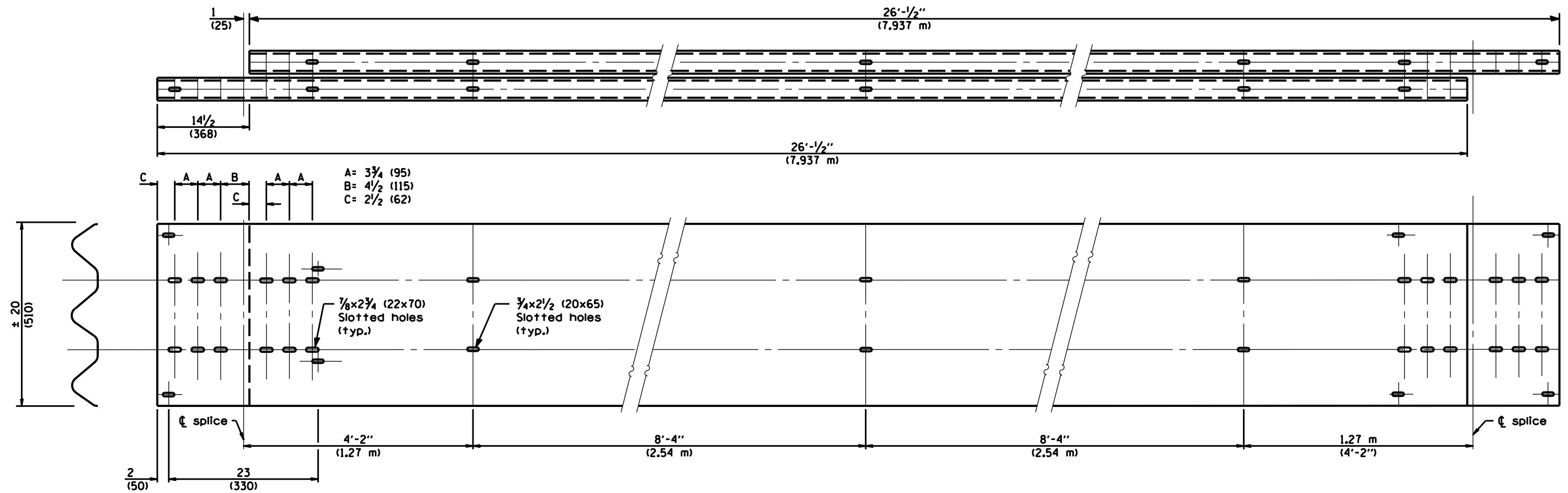
**GENERAL NOTES**

Plate Washers B are to be placed under both heads and nuts of splicing bolts for internal splice and internal expansion splice joint.

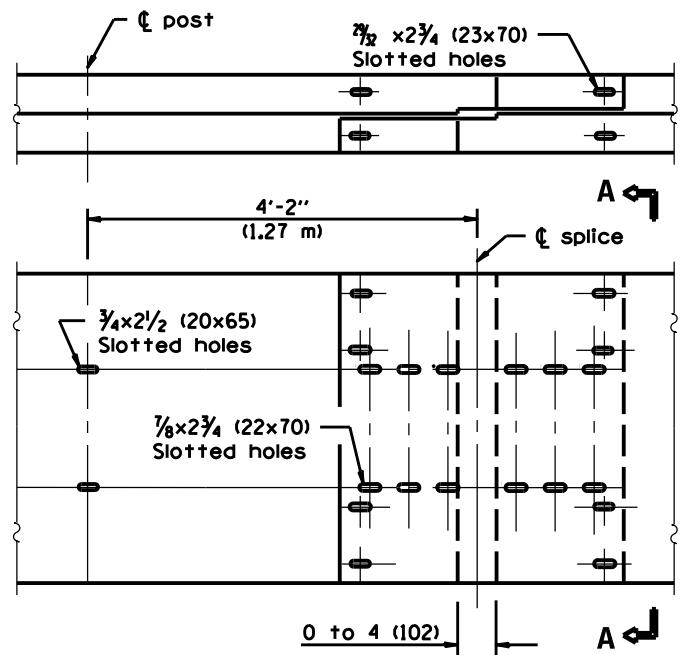
Plate Washers C are to be placed under both heads and nuts of splicing bolts for lap expansion and internal lap splice joint.

See Standard 630001 for details of guardrail not shown.

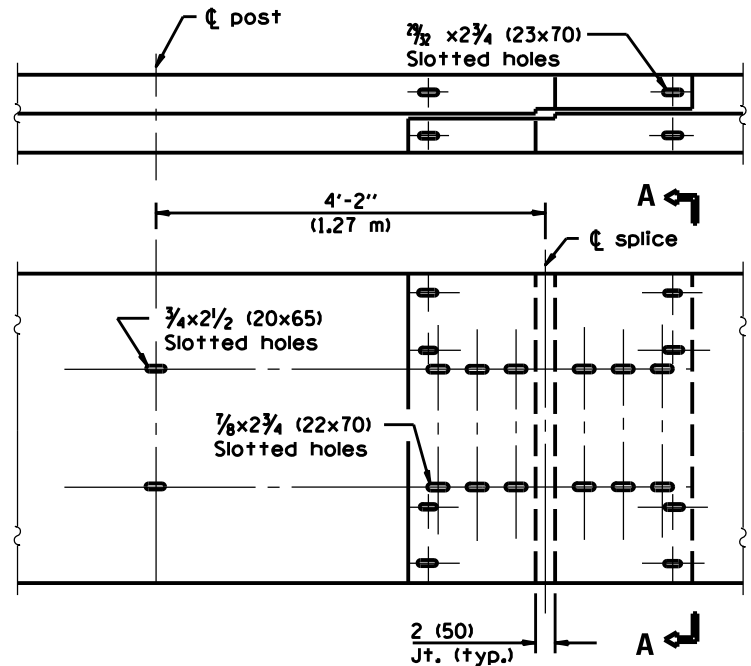
All dimensions are in inches (millimeters) unless otherwise shown.



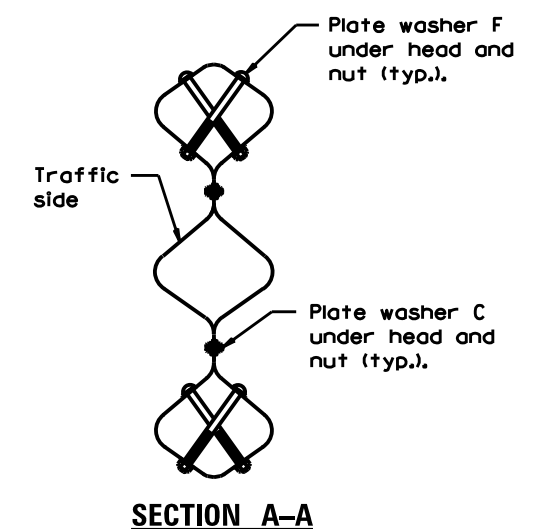
**TUBULAR THRIE BEAM FOR LAP SPLICE JOINT**



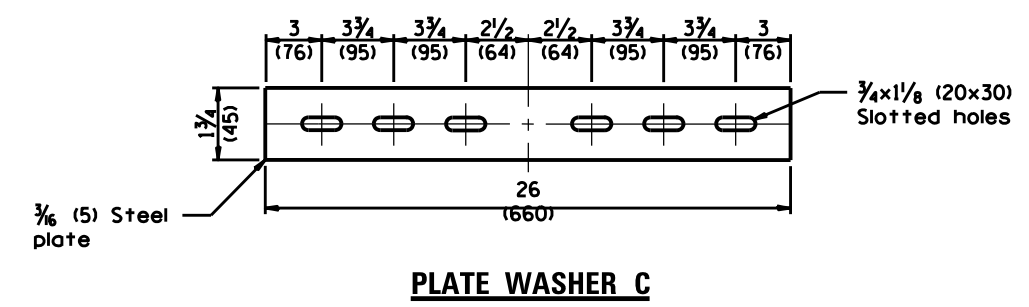
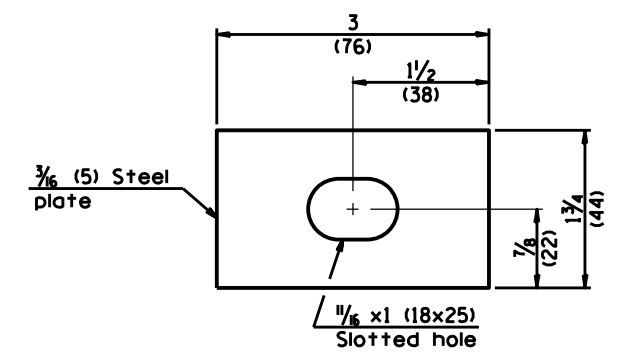
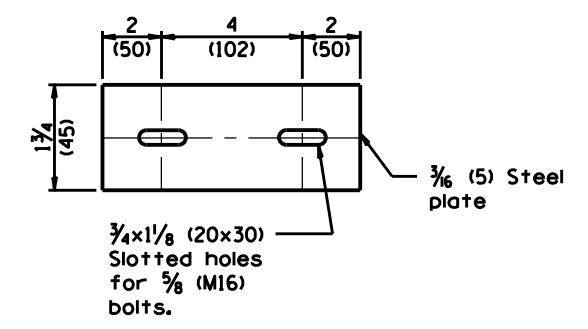
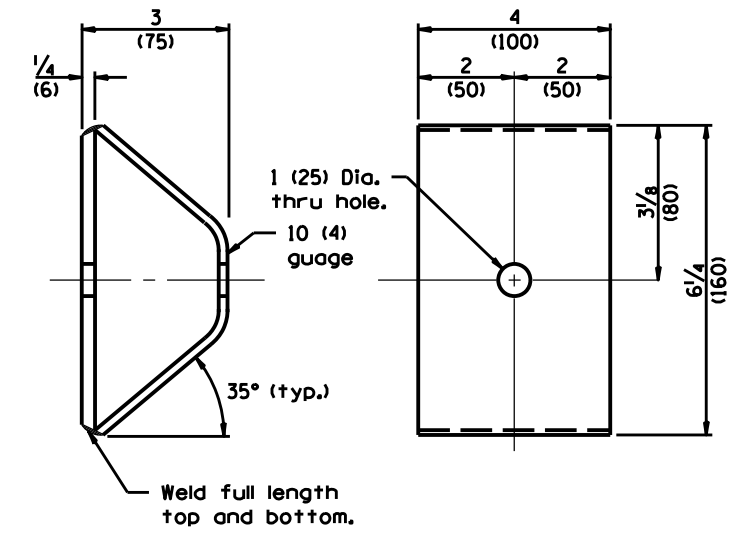
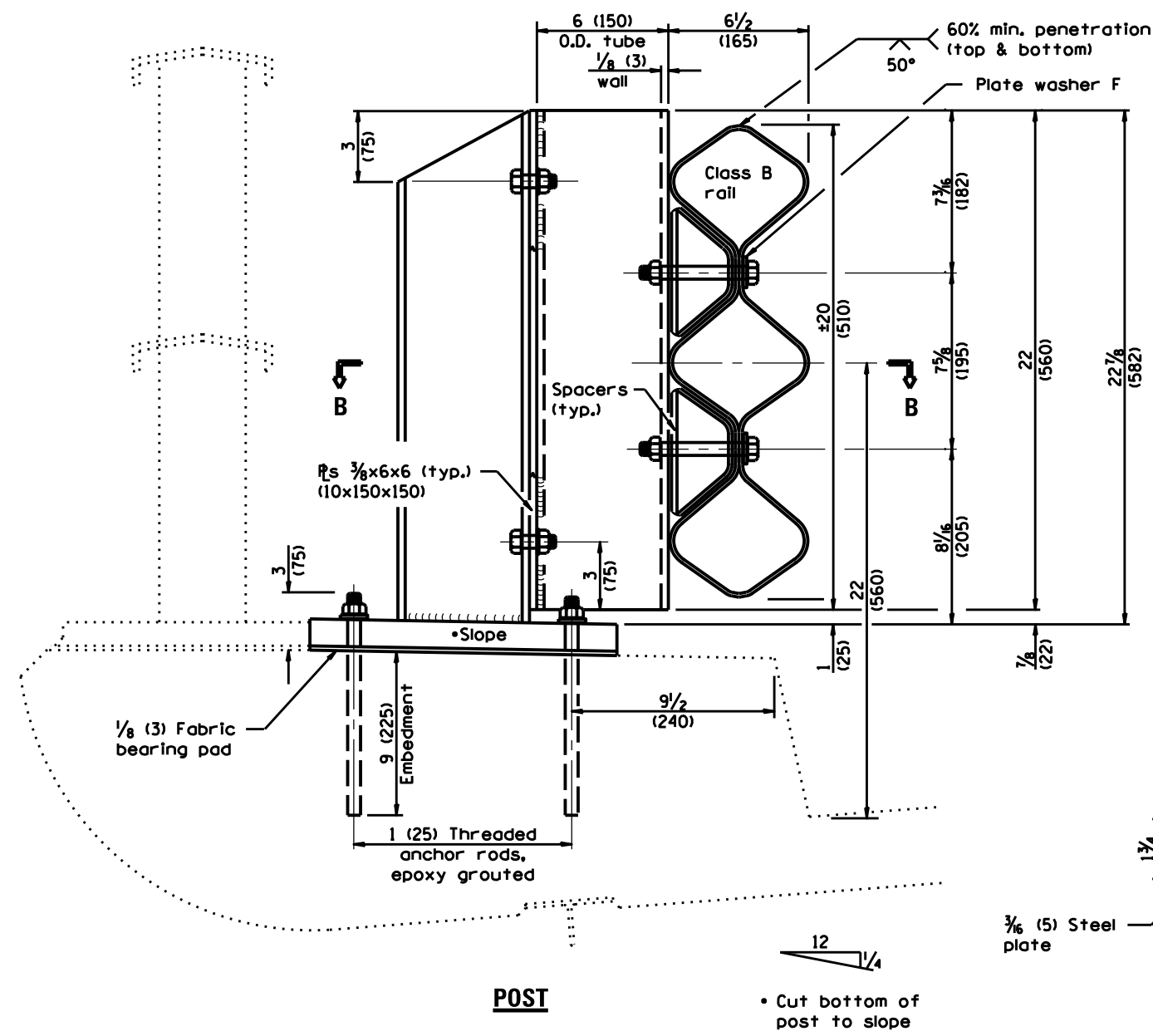
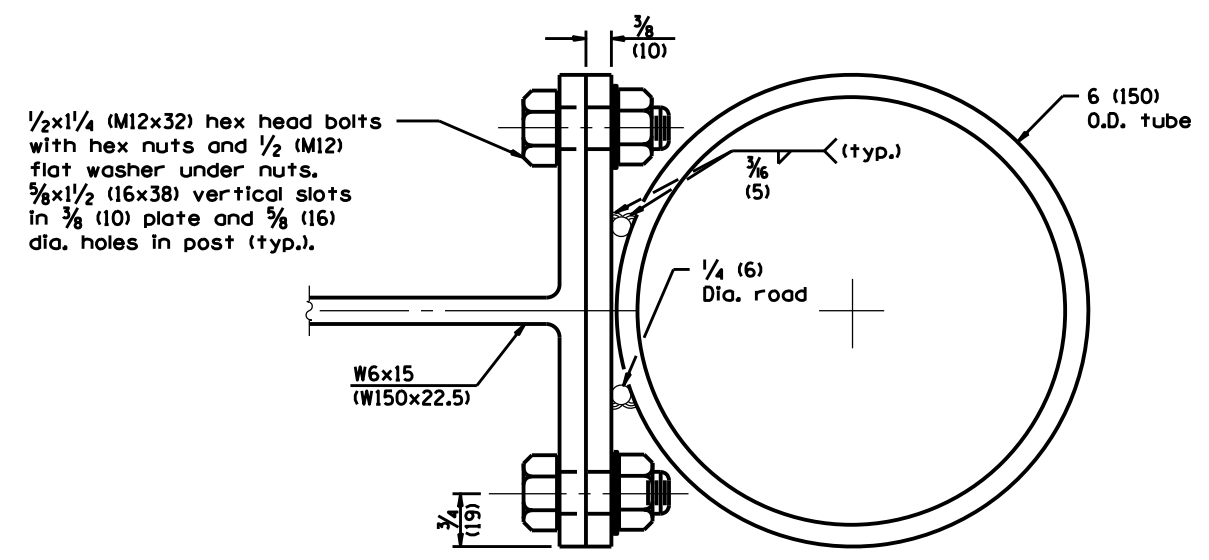
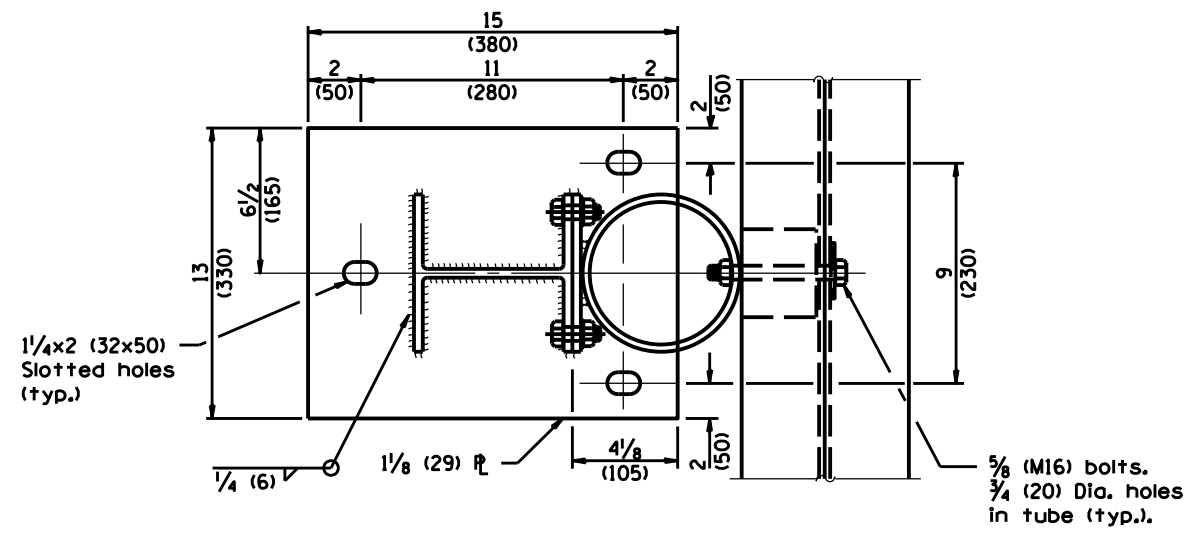
**LAP EXPANSION SPLICE JOINT**



**LAP SPLICE JOINT**



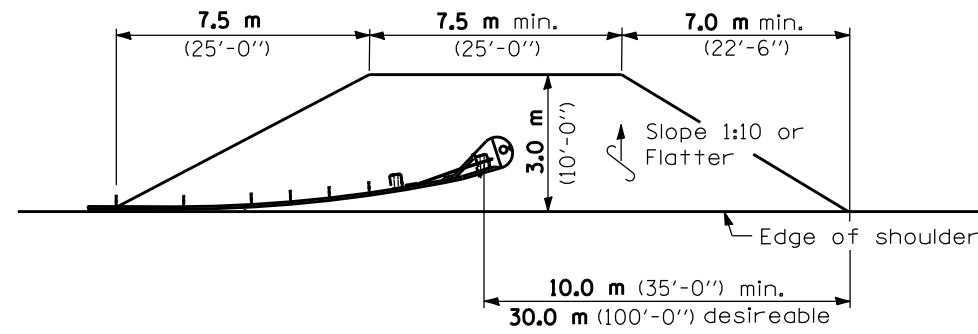
FILE NAME =	USER NAME = \$USER\$	DESIGNED -	REVISED -	STATE OF ILLINOIS DEPARTMENT OF TRANSPORTATION	TUBULAR THRIE BEAM RETROFIT RAIL FOR BRIDGES		F.A. RTE.	SECTION	COUNTY	TOTAL SHEETS	SHEET NO.
\$FILE\$		DRAWN -	REVISED -		SCALE: _____	SHEET 2 OF 3 SHEETS	STA. _____	TO STA. _____	VAR.	43	11
\$MODELNAME\$		CHECKED -	REVISED -		CONTRACT NO. 66015						
		DATE -	REVISED -		ILLINOIS FED. AID PROJECT						



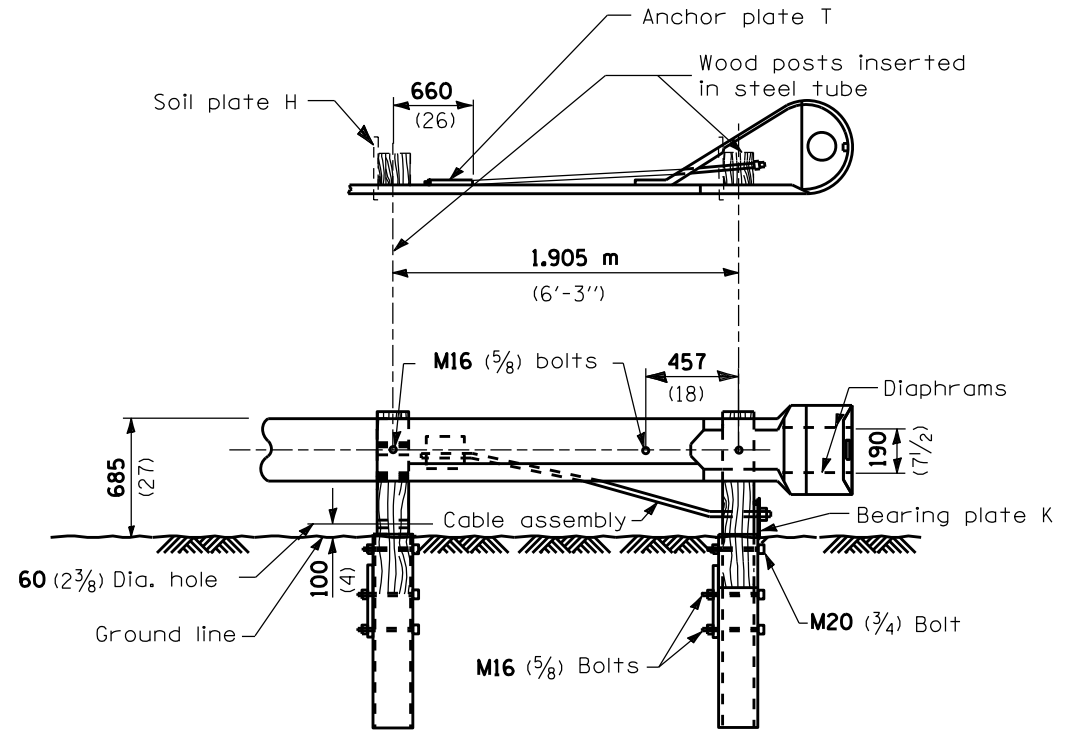
12  
• Cut bottom of post to slope

OFFSETS TO FACE OF RAIL

Post	X <sub>m</sub> (ft)	Y <sub>m</sub> (ft)
①	11.345 (37.22)	1.22 (4.0)
②	9.475 (31.09)	0.850 (2.79)
③	7.595 (24.92)	0.545 (1.79)
④	6.335 (20.79)	0.380 (1.25)
⑤	5.070 (16.64)	0.245 (0.80)
⑥	3.805 (12.49)	0.135 (0.45)
⑦	1.905 (6.25)	0.035 (0.11)
⑧	0 (0.00)	0 (0.00)



**SHOULDER WIDENING TRANSITION**



**WOOD BREAKAWAY POSTS  
TUBULAR STEEL FOUNDATIONS**

**GENERAL NOTES**

See Standard 630001 for details of guardrail not shown.

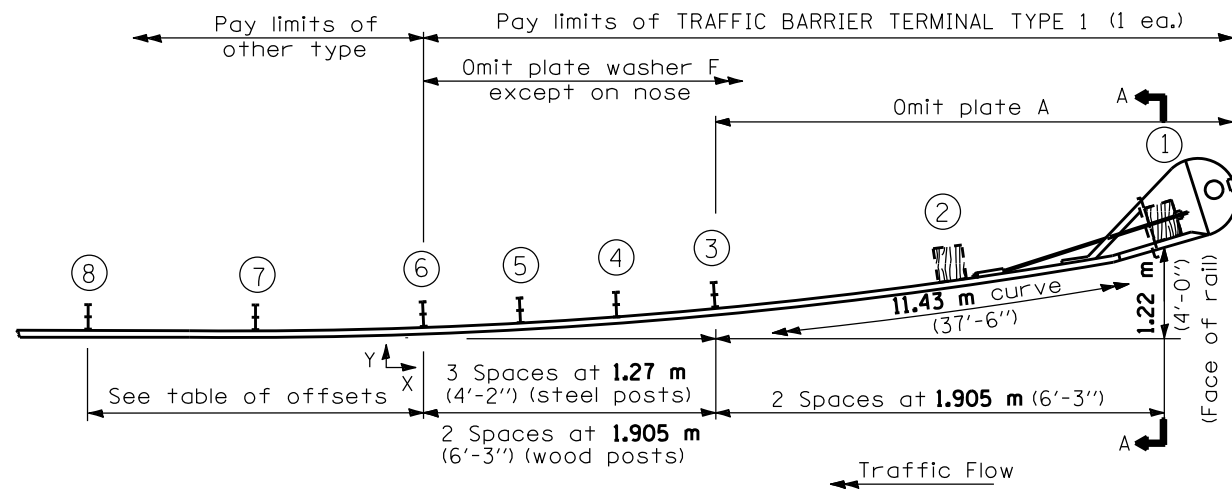
Posts at location 1 & 2 shall be wood breakaway posts. Posts other than 1 & 2 may be either standard wood posts or steel posts, at the option of the Contractor. If standard wood posts are used, one post shall be located midway between and in lieu of posts 4 & 5. The offset (Y) for this post shall be 300 mm (12 inches).

A two-piece assembly may be substituted for the one piece nose shown above.

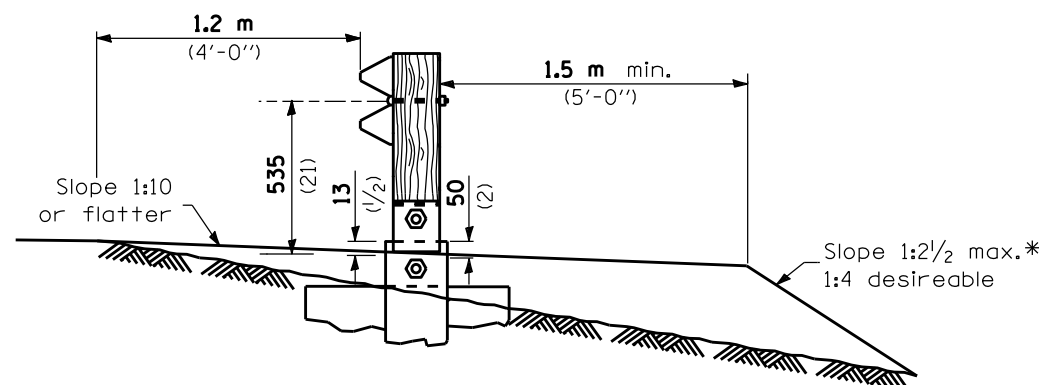
The bearing plate K shall be held in position by (2) two eightpenny nails driven into the post and bent over the top of the plate.

All slope ratios are expressed as units of vertical displacement to units of horizontal displacement (V:H).

All dimensions are in millimeters (inches) unless otherwise shown.



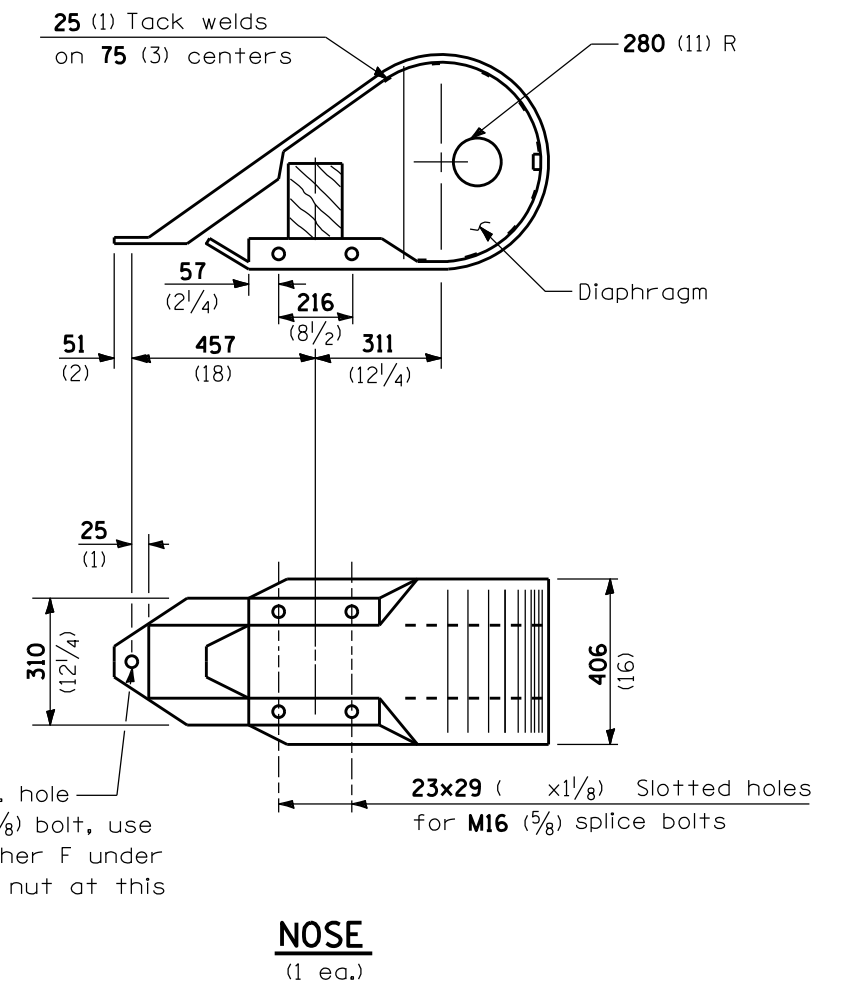
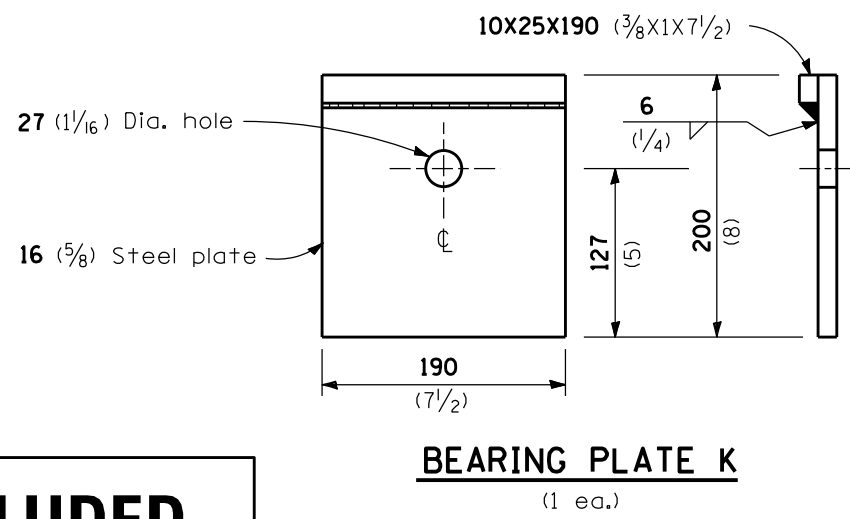
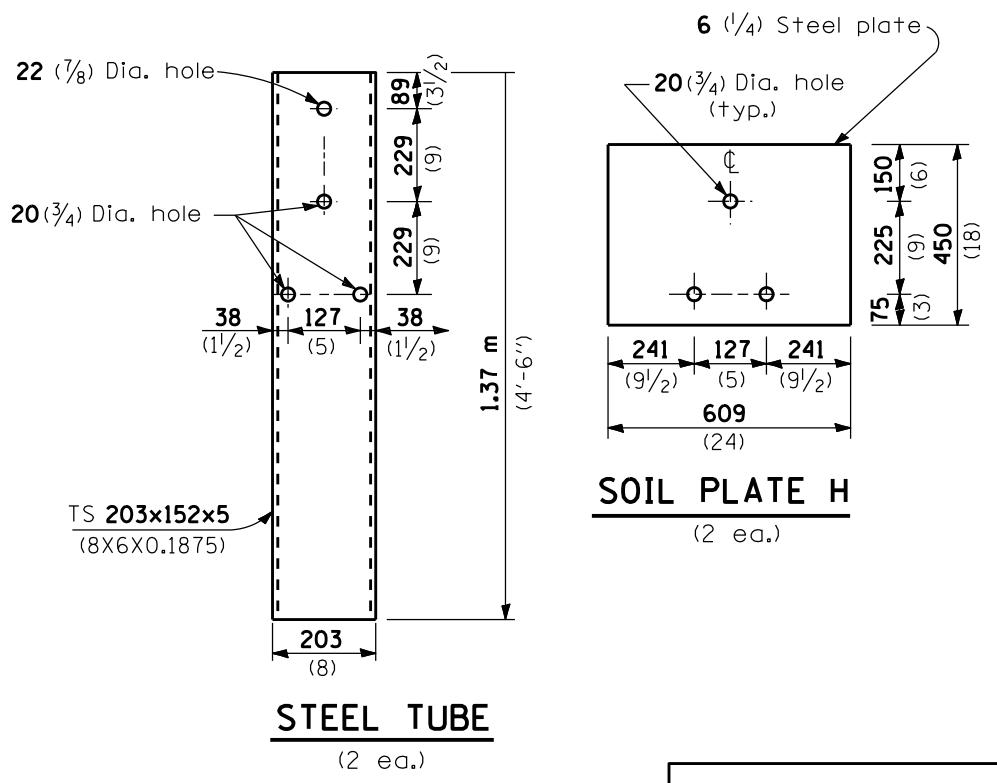
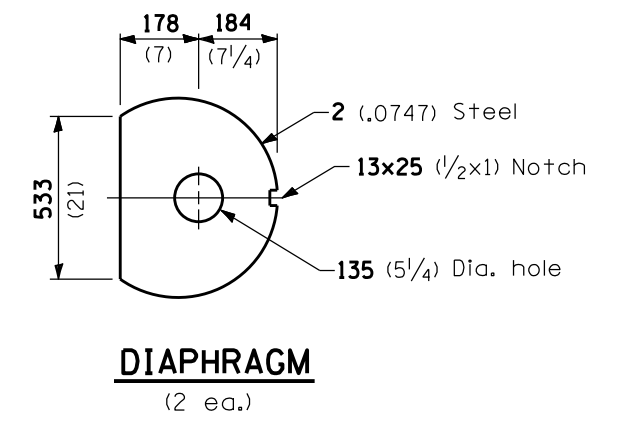
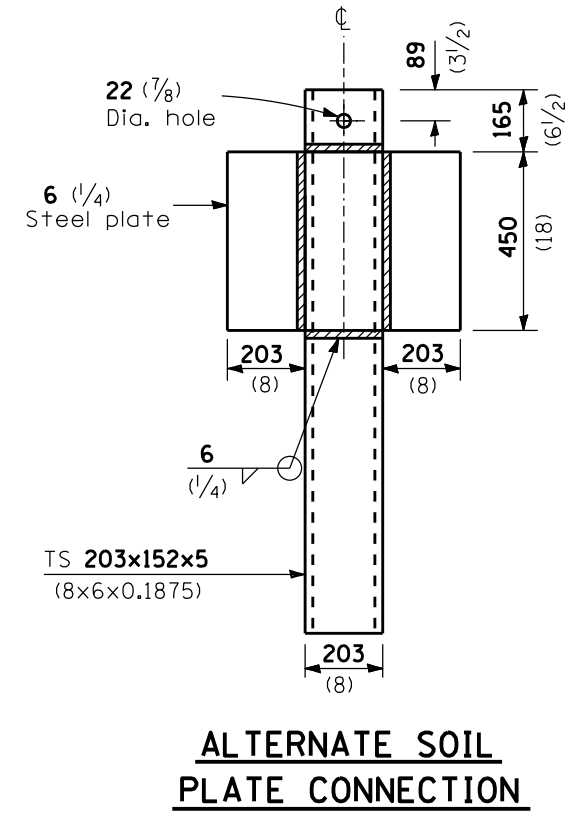
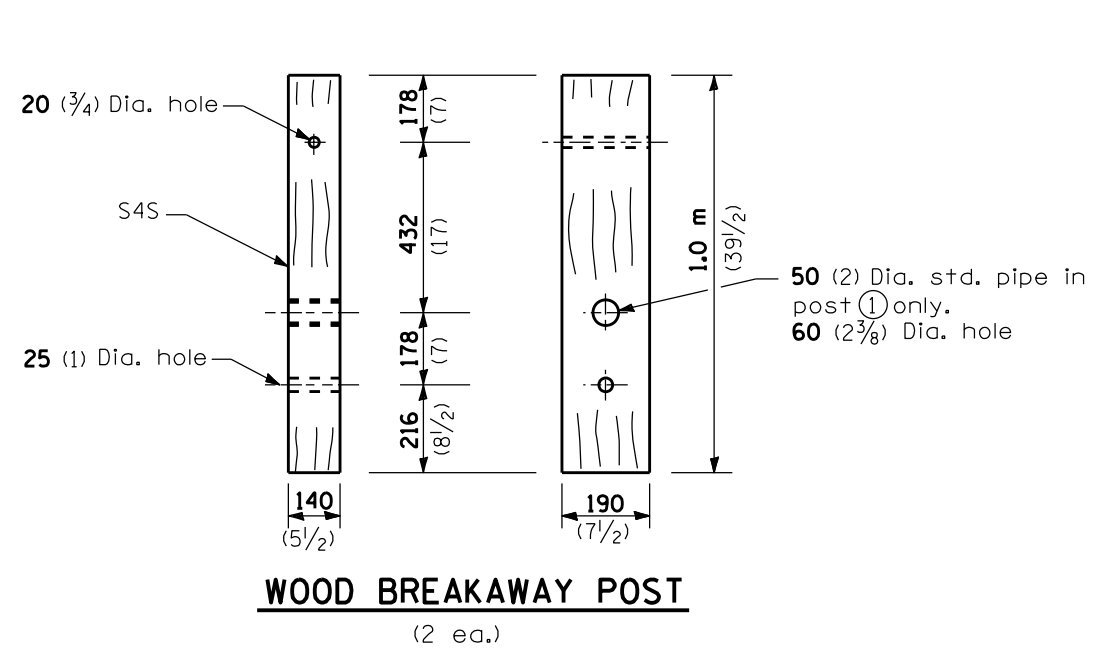
**PLAN**



**SECTION A-A**

\* If fill height exceeds 1.5 m (5'-0'') use 1:3 max.

**DETAIL INCLUDED  
FOR REPAIR ONLY**

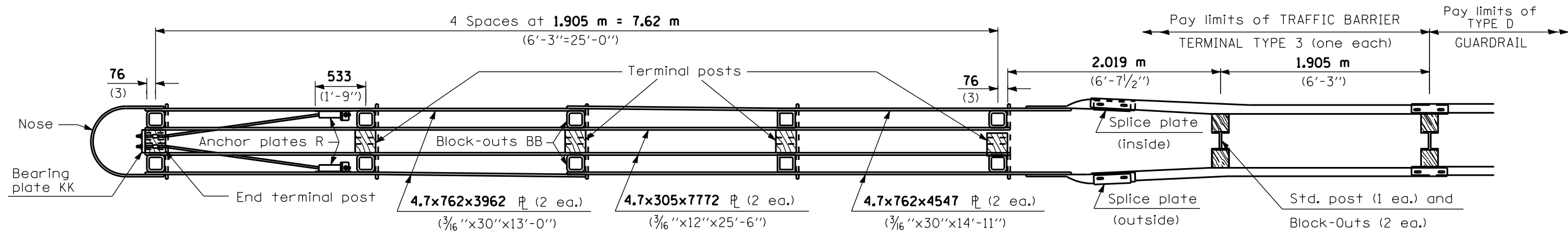


**DETAIL INCLUDED  
FOR REPAIR ONLY**

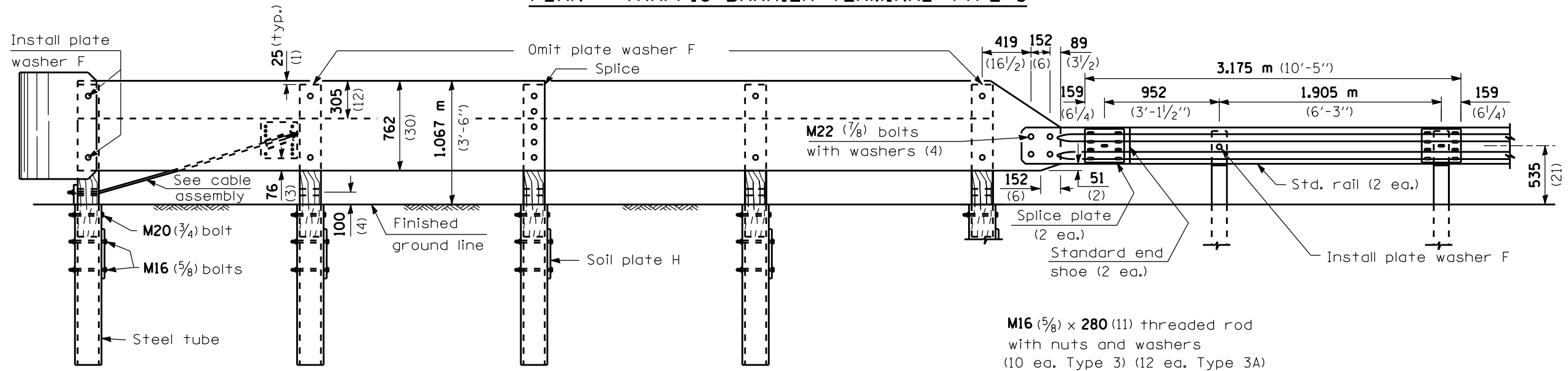
All dimensions are in millimeters (inches) unless otherwise shown.

• D-3 HIGHWAY DAMAGE REPAIR 2015

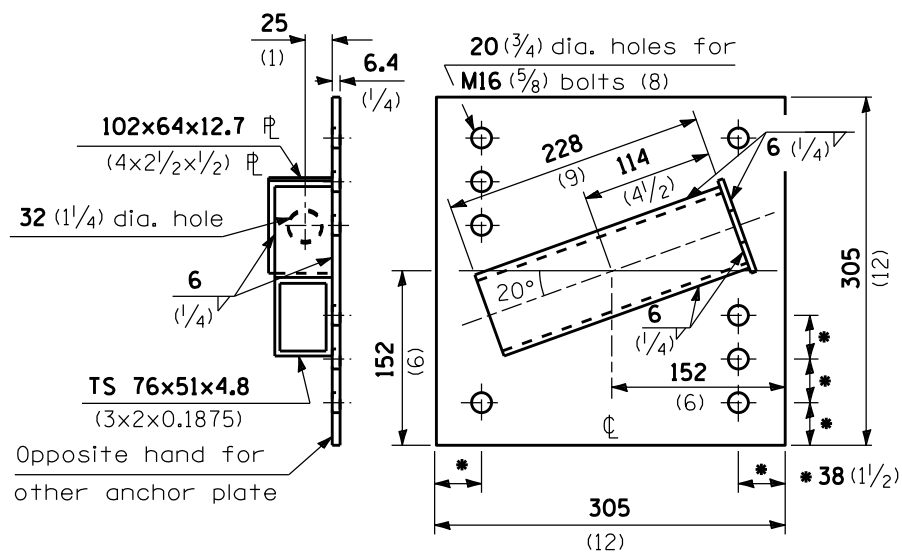
FILE NAME =	USER NAME = \$USER\$	DESIGNED -	REVISED -	STATE OF ILLINOIS DEPARTMENT OF TRANSPORTATION	TRAFFIC BARRIER TERMINAL TYPE 1 STANDARD B.L.R. 23	F.A. RTE.	SECTION	COUNTY	TOTAL SHEETS	SHEET NO.	
*FILE#		DRAWN -	REVISED -			SCALE:	SHEET NO. OF SHEETS	VAR.	VAR.	43	14
	PLOT SCALE = \$SCALE\$	CHECKED -	REVISED -			STA. TO STA.	FED. ROAD DIST. NO.	ILLINOIS FED. AID PROJECT	CONTRACT NO. 66015		
	PLOT DATE = \$DATE\$	DATE -	REVISED -								



PLAN - TRAFFIC BARRIER TERMINAL TYPE 3

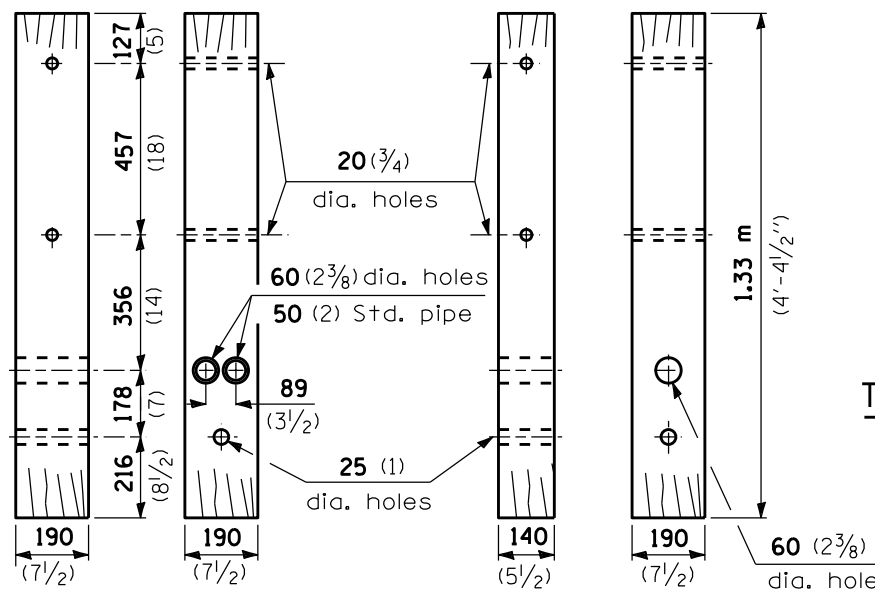


ELEVATION



ANCHOR PLATE R

(1 ea. lt. hd. & 1 ea. rt. hd.)

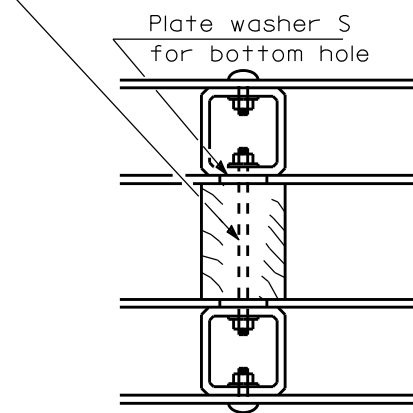


END TERMINAL POST

(1 ea.)

TERMINAL POST

(4 ea. Type 3) (5 ea. Type 3A)



TYPICAL BLOCK-OUT/POST ATTACHMENT

GENERAL NOTES

All holes in Posts, Block-Outs and Plates shall be 20 mm (3/4") diameter unless otherwise noted.

See Standard 630001 for details of guardrail elements not shown.

Unless otherwise shown all bolts and nuts shall be Standard Post and Splice Bolts and Nuts (See Standard 630001).

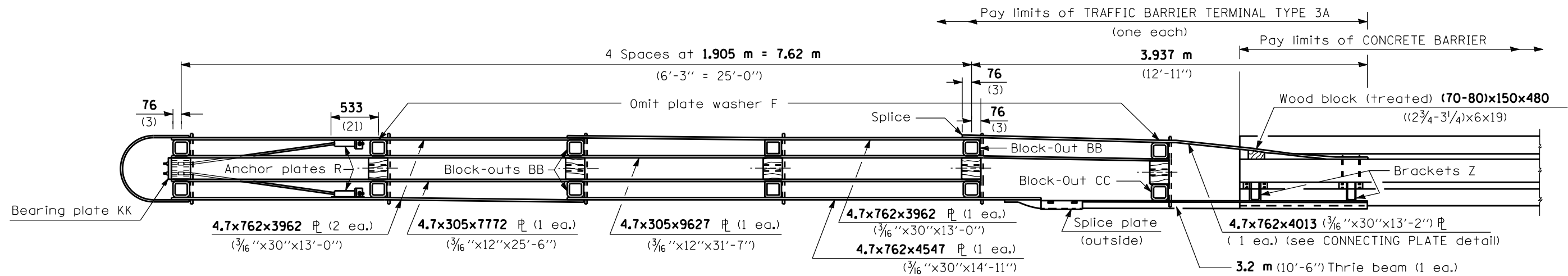
Block-Out AA shall be used at all locations unless otherwise noted.

**DETAIL INCLUDED FOR REPAIR ONLY**

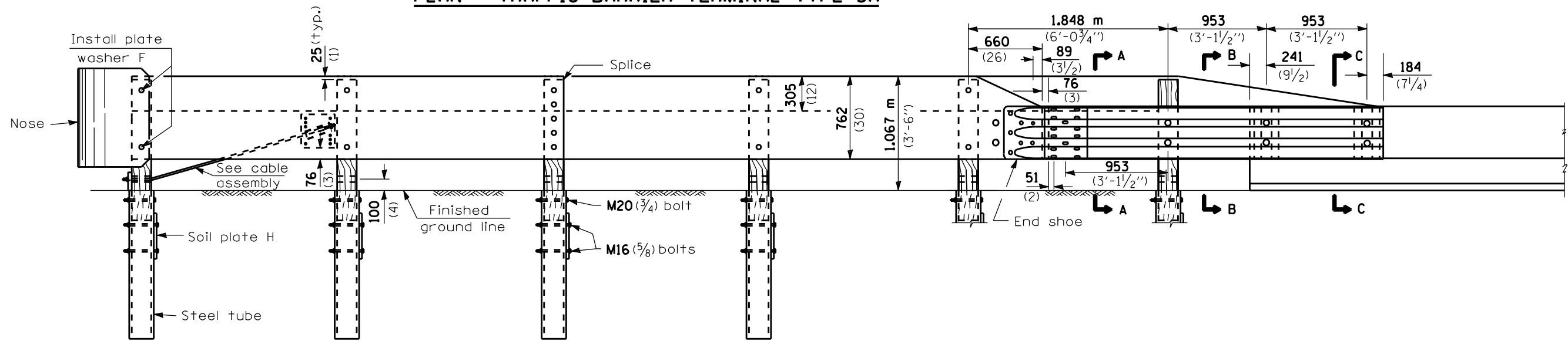
All dimensions are in millimeters (inches) unless otherwise shown.

D-3 HIGHWAY DAMAGE REPAIR 2015

FILE NAME =	USER NAME = #USER#	DESIGNED -	REVISED -	STATE OF ILLINOIS DEPARTMENT OF TRANSPORTATION	TRAFFIC BARRIER TERMINAL TYPE 3 & 3A	F.A. RTE.	SECTION	COUNTY	TOTAL SHEETS	SHEET NO.	
#FILE#		DRAWN -	REVISED -			Y&B		Y&B	43	15	
		CHECKED -	REVISED -			SCALE: _____ SHEET NO. _____ OF _____ SHEETS STA. _____ TO STA. _____		CONTRACT NO. 66015			
		DATE	REVISED			FED. ROAD DIST. NO. ILLINOIS FED. AID PROJECT					

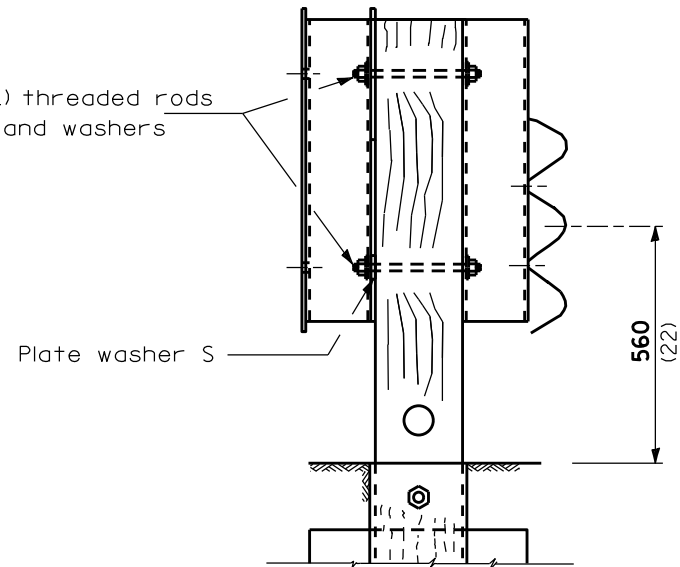


**PLAN - TRAFFIC BARRIER TERMINAL TYPE 3A**



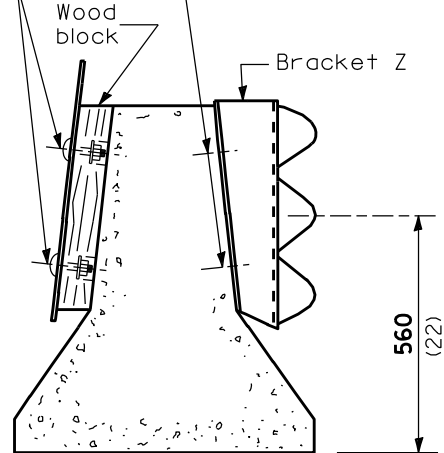
**ELEVATION**

2- M16x280 (5/8x11) threaded rods with nuts and washers



**SECTION A-A**

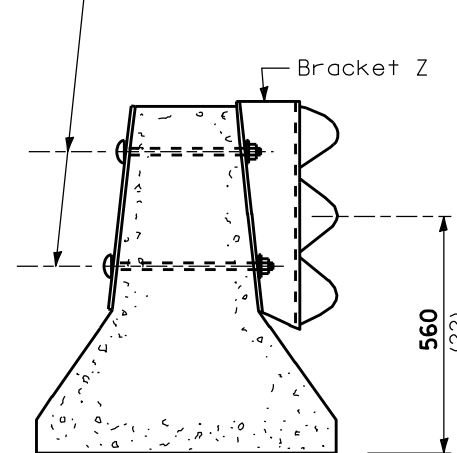
2- M16 (5/8) button head bolts with hex nuts and washers recessed in wood block.



**SECTION B-B**

4 - 2 unit expanding or self-drilling anchors for M16 (5/8) bolts with standard washers

4- M16 (5/8) button head bolts with hex nuts and washers installed thru concrete barrier, with button head on plate side. Pre-drill 25 (1) dia. holes in concrete barrier.



**SECTION C-C**

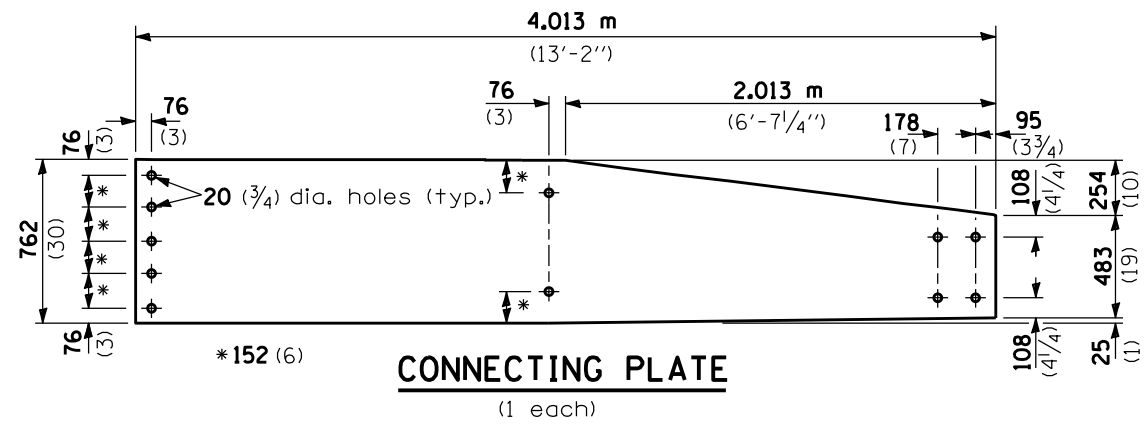
**DETAIL INCLUDED FOR REPAIR ONLY**

All dimensions are in millimeters (inches) unless otherwise shown.

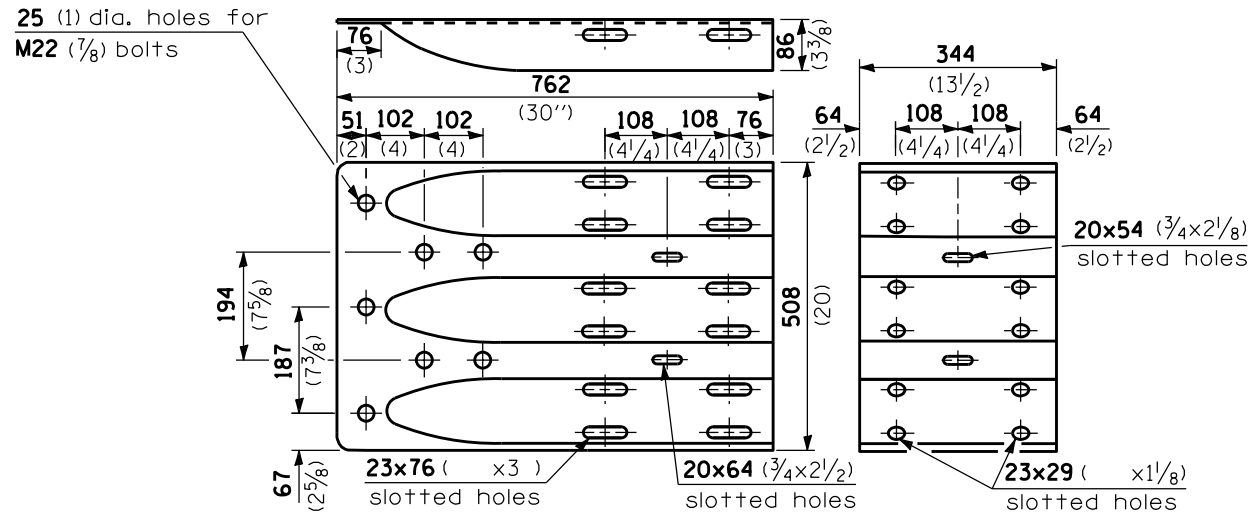
FILE NAME =	USER NAME = \$USER\$	DESIGNED -	REVISED -	STATE OF ILLINOIS DEPARTMENT OF TRANSPORTATION	TRAFFIC BARRIER TERMINAL TYPE 3 & 3A	F.A. RTE.	SECTION	COUNTY	TOTAL SHEETS	SHEET NO.	
*FILEL\$		DRAWN -	REVISED -			VAR.		VAR.	43	16	
		CHECKED -	REVISED -			CONTRACT NO. 66015					
		DATE	REVISED -			FED. ROAD DIST. NO. ILLINOIS FED. AID PROJECT					
				SCALE: _____ SHEET NO. _____ OF _____ SHEETS STA. _____ TO STA. _____							



**TYPE 3A ONLY**

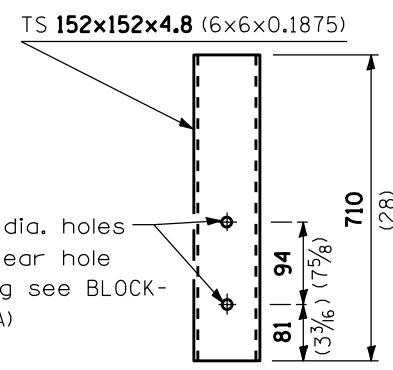


**CONNECTING PLATE**  
(1 each)

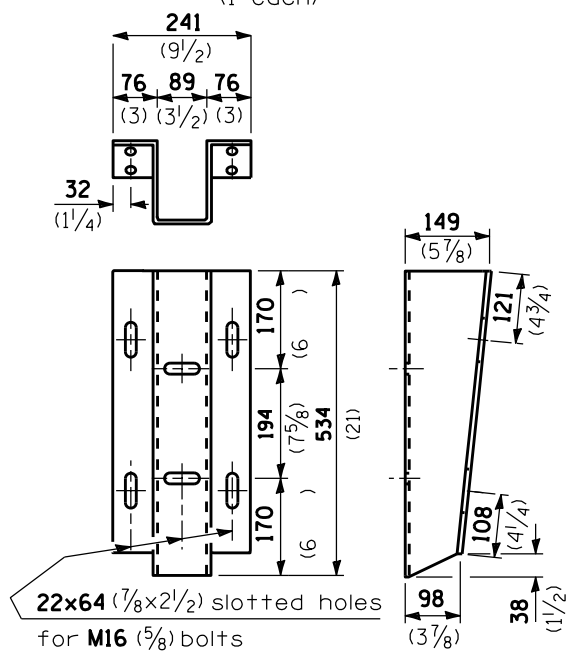


**THRIE BEAM END SHOE**  
(1 each)

**SPLICE PLATE**  
(1 each)



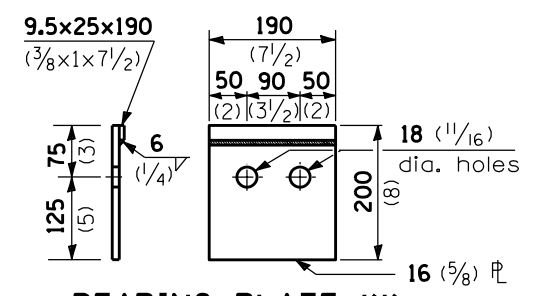
**BLOCK-OUT CC FOR THRIE BEAM**  
(1 each)



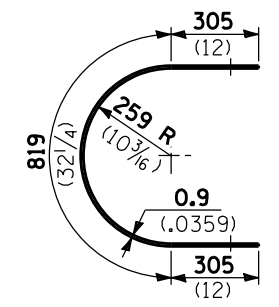
**BRACKET Z**  
(2 each)

(6.4 1/4) steel plate or section of rectangular tubing with flanges welded on

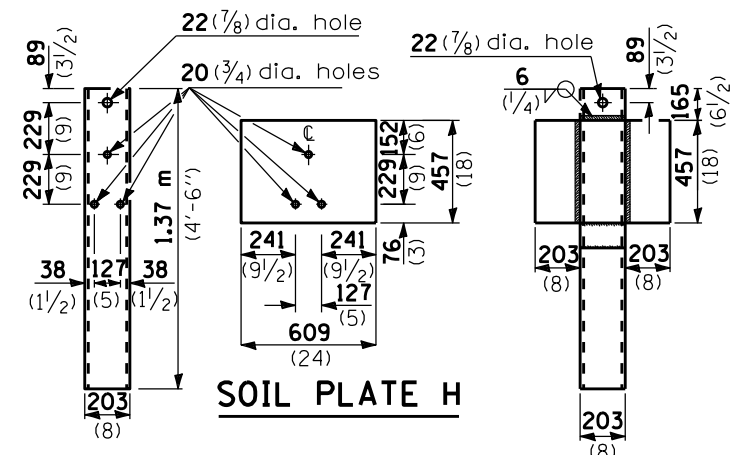
**TYPE 3 & 3A**



**BEARING PLATE KK**  
(1 each)



**NOSE**  
(1 ea.)

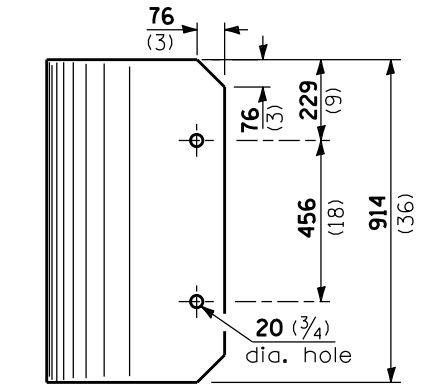


**STEEL TUBE**

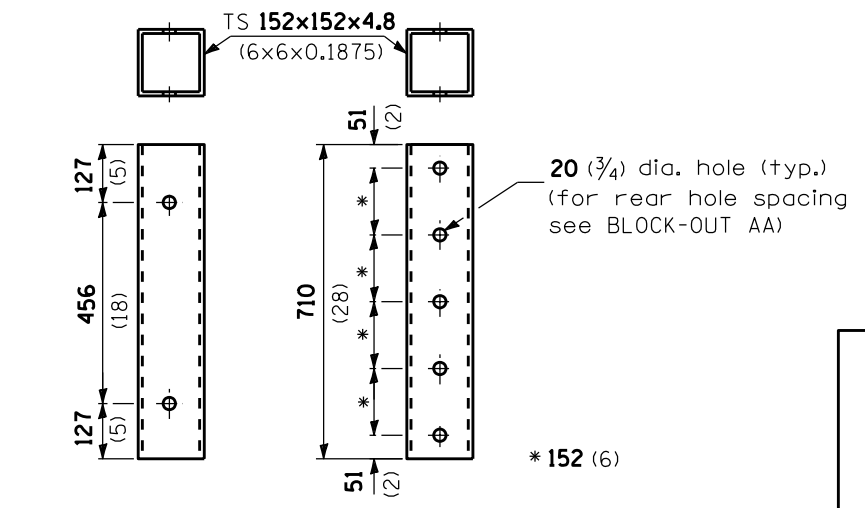
TS 203x203x4.8 (8x8x0.1875) (end terminal post) (1 ea.)

TS 203x152x4.8 (8x6x0.1875) (terminal post) (4 ea. Type 3) (5 ea. Type 3A)

**ALTERNATE SOIL PLATE CONNECTION**



**PLATE WASHER S**  
(10 ea. Type 3)  
(11 ea. Type 3A)



**BLOCK-OUT AA**  
(8 ea.)

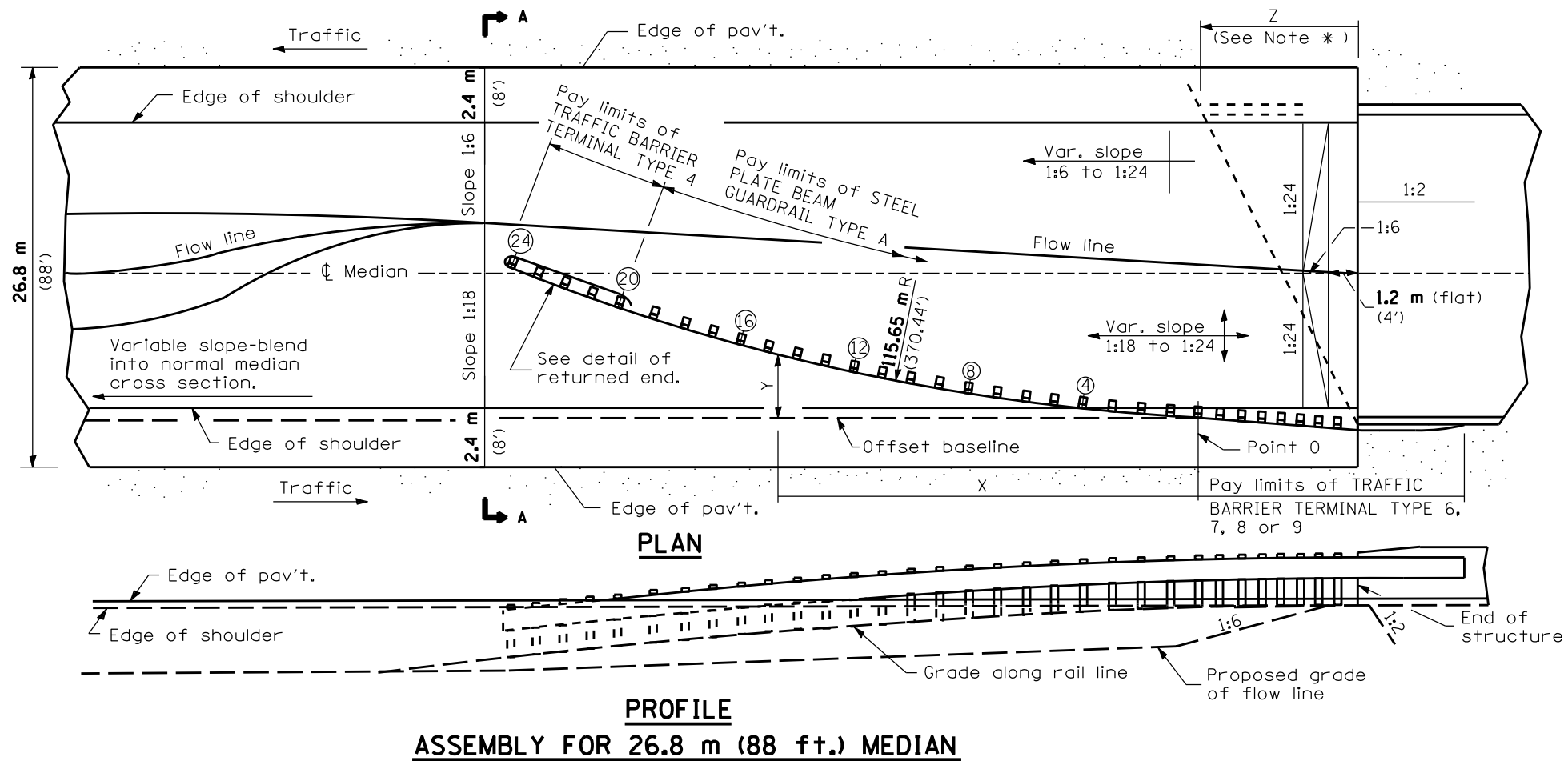
**BLOCK-OUT BB AT SPLICE**  
(2 ea. Type 3)  
(3 ea. Type 3A)

**DETAIL INCLUDED FOR REPAIR ONLY**

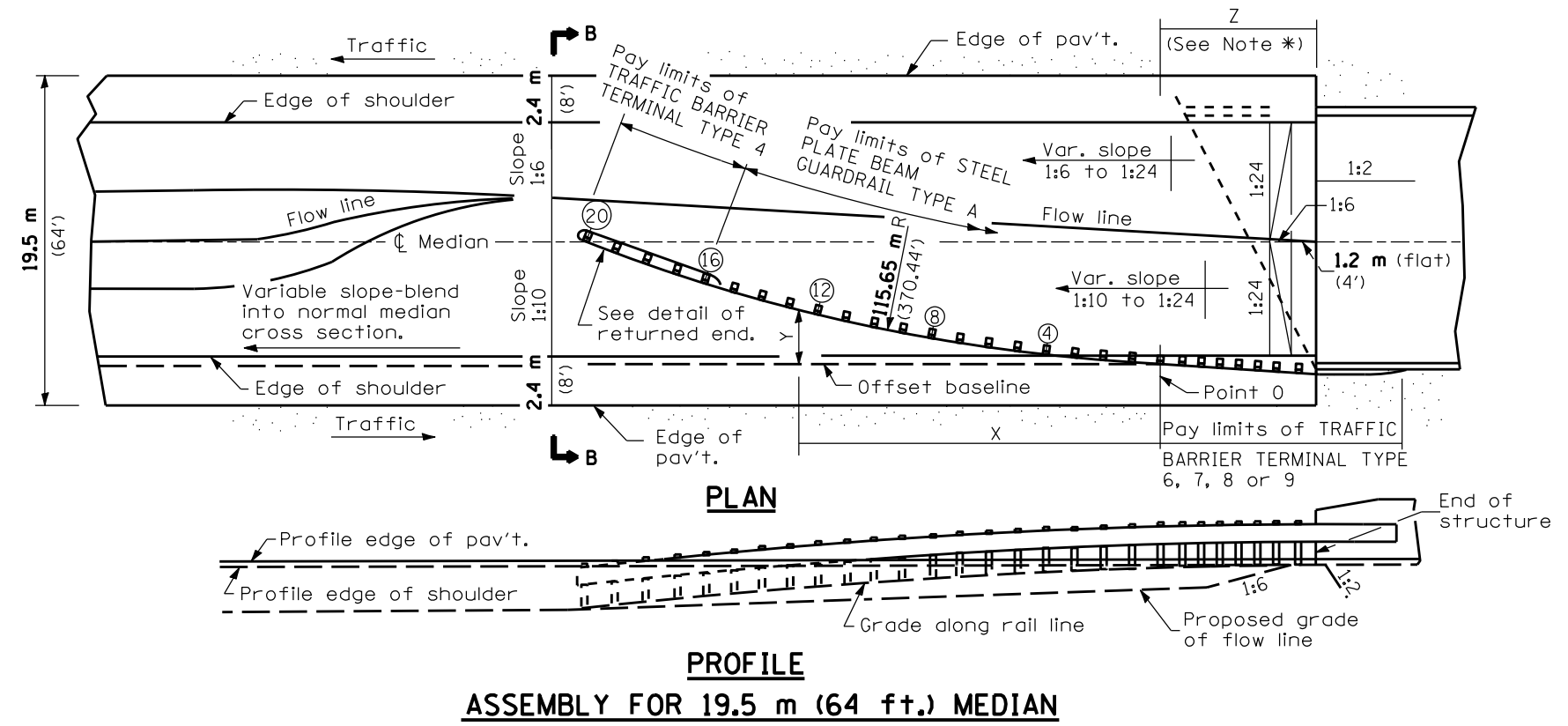
All dimensions are in millimeters (inches) unless otherwise shown.

• D-3 HIGHWAY DAMAGE REPAIR 2015

FILE NAME =	USER NAME = \$USER\$	DESIGNED -	REVISD -	STATE OF ILLINOIS DEPARTMENT OF TRANSPORTATION	TRAFFIC BARRIER TERMINAL TYPE 3 & 3A	F.A. RTE.	SECTION	COUNTY	TOTAL SHEETS	SHEET NO.	
*FILEL\$		DRAWN -	REVISD -			Y&R.		Y&R.	43	17	
		CHECKED -	REVISD -			CONTRACT NO. 66015					
		DATE -	REVISD -			FED. ROAD DIST. NO. ILLINOIS FED. AID PROJECT					



**PROFILE**  
**ASSEMBLY FOR 26.8 m (88 ft.) MEDIAN**



**PROFILE**  
**ASSEMBLY FOR 19.5 m (64 ft.) MEDIAN**

**OFFSETS TO FACE OF RAIL**

POST	DISTANCE X m (ft.)	OFFSET Y m (ft.)
POINT 0	0 (0)	0 (0)
④	7.60 (24.93)	0.56 (1.83)
⑧	15.14 (49.68)	1.60 (5.28)
⑫	22.60 (74.16)	3.16 (10.37)
⑰	29.94 (98.23)	5.20 (17.05)
⑳	37.13 (121.83)	7.71 (25.3)
㉑	44.14 (144.83)	10.70 (35.09)

Offsets (Y) are measured between the face of rail and the offset baseline, which is parallel to the pavement edge and passes through point 0.

The location of point 0 will vary, being dependent on structure details and the type of traffic barrier terminal utilized.

**GENERAL NOTES**

See Standard 630001 for details of guard-rail not shown.

\*For dual structures skewed right forward, the nose of the Type 4 terminal shall be positioned longitudinally away from the structure for a distance equal to dimension Z. Appropriate adjustments to the length of the Type A guardrail and its offsets (Y) shall be calculated and used. All additional lengths of guardrail shall be in increments of 3.87 m (12'-6").

For dual structures that are 90° or skewed left forward, the length of guardrail is appropriate.

The bearing plate K shall be held in position by (2) two eight penny nails driven into the post and bent over the top of the plate.

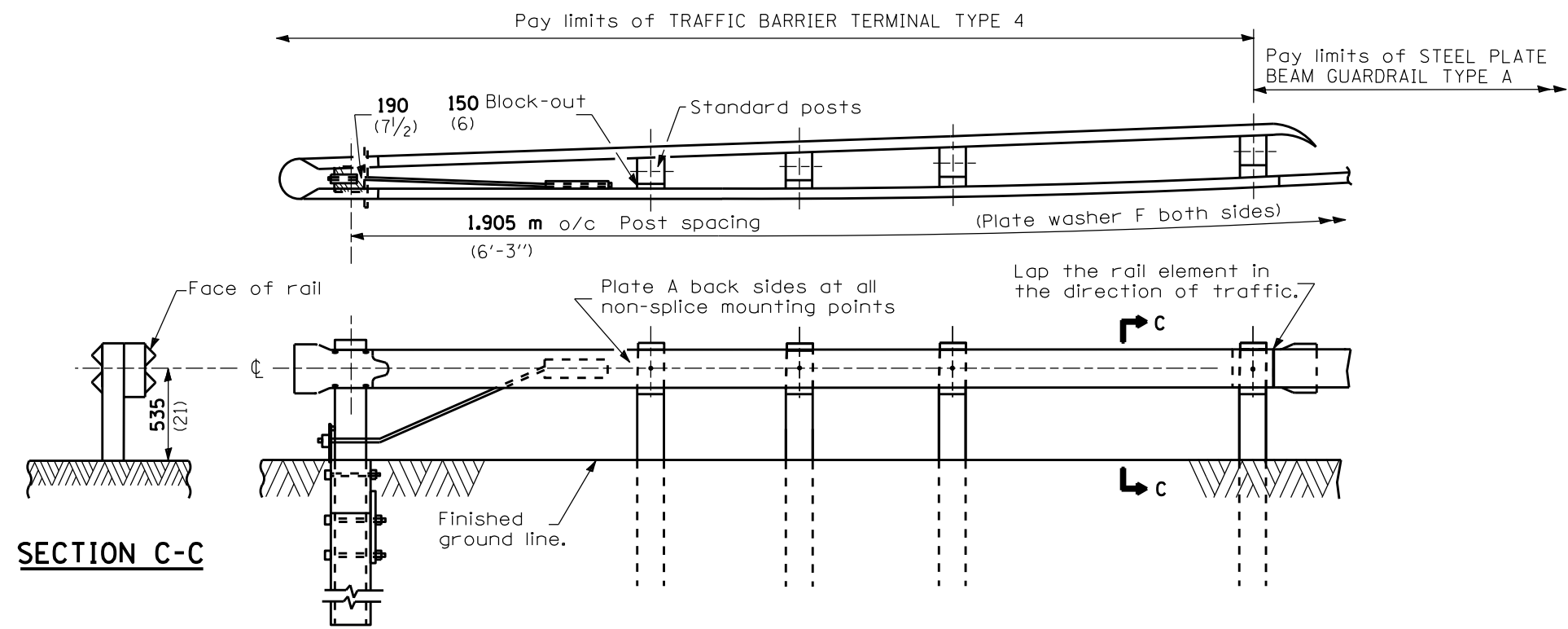
All slopes are expressed as units of vertical displacement to units of horizontal displacement (V:H).

All dimensions are in millimeters (inches) unless otherwise shown.

**DETAIL INCLUDED  
FOR REPAIR ONLY**

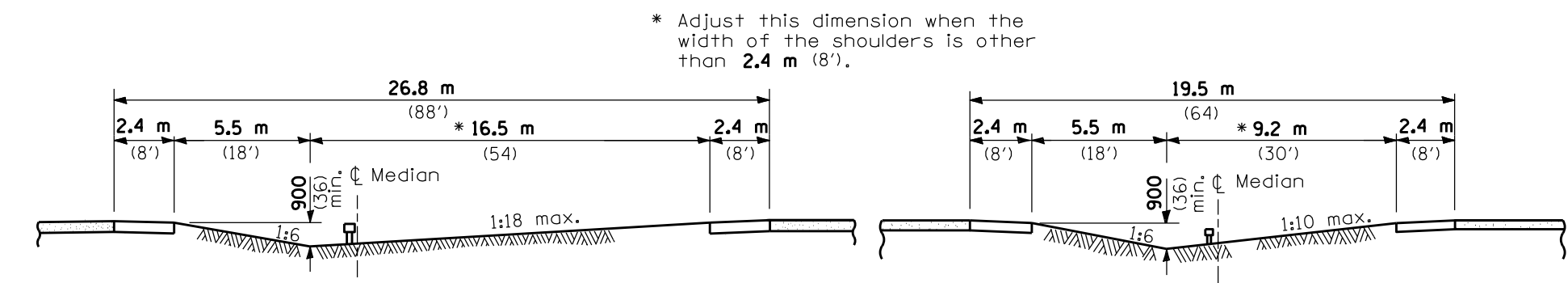
All dimensions are in millimeters (inches) unless otherwise shown.

• D-3 HIGHWAY DAMAGE REPAIR 2015



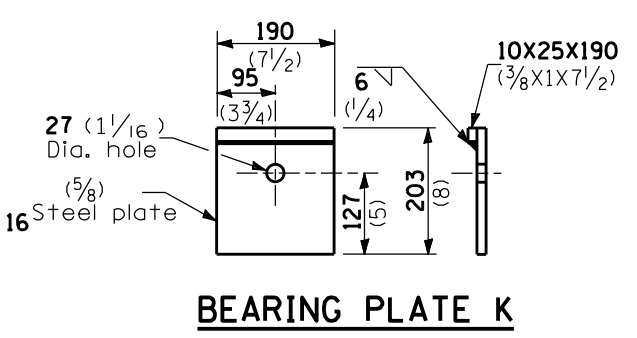
**SECTION C-C**

**RETURNED END DETAIL**

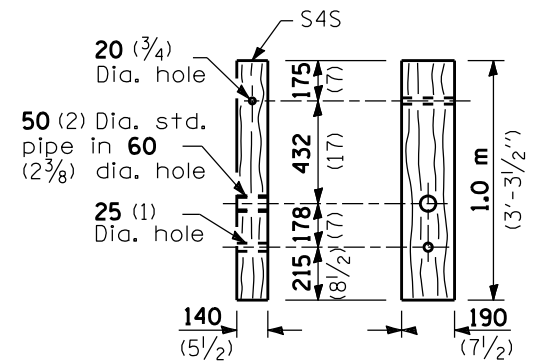


**SECTION A-A**

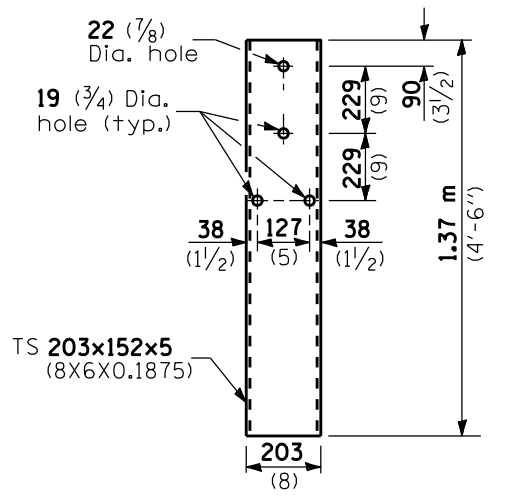
**SECTION B-B**



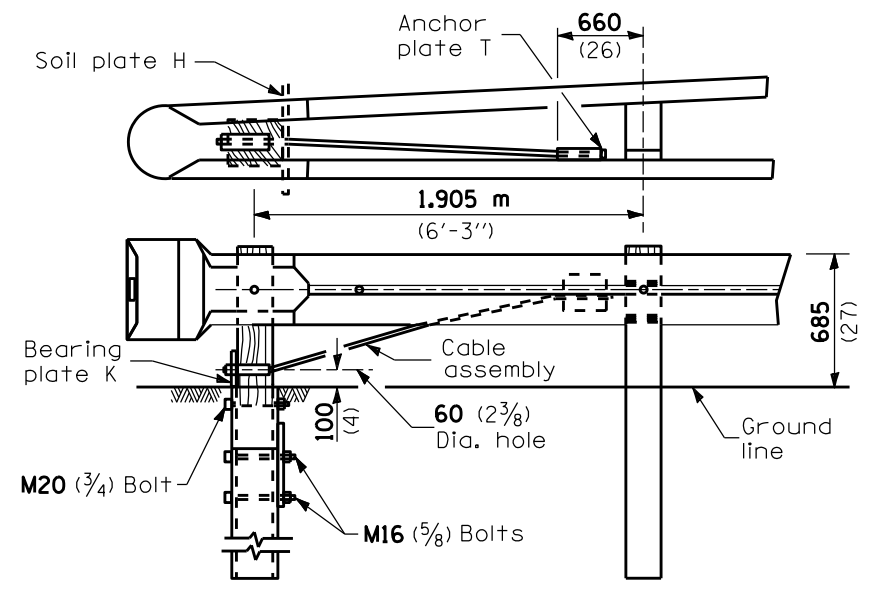
**BEARING PLATE K**



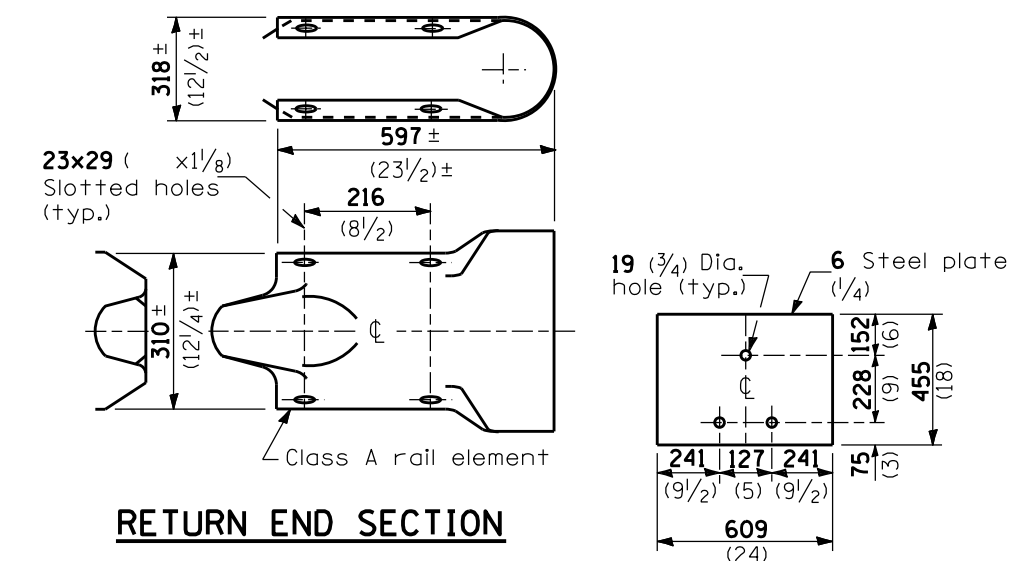
**WOOD BREAKAWAY POST**



**STEEL TUBE**

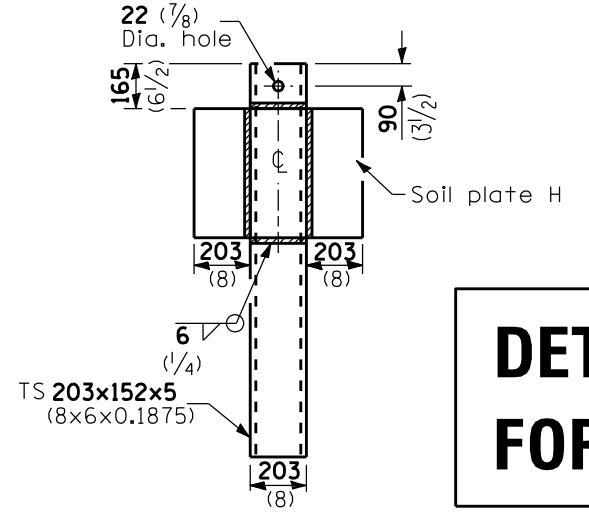


**WOOD POST TUBULAR STEEL FOUNDATION**



**RETURN END SECTION**

**SOIL PLATE H**



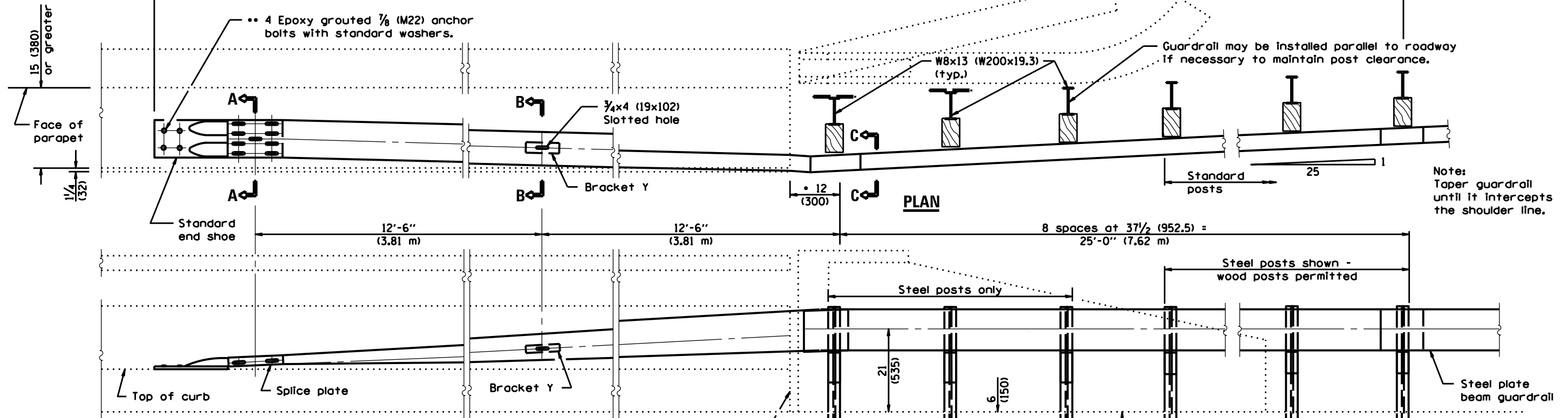
**ALTERNATE SOIL PLATE CONNECTION**

**DETAIL INCLUDED FOR REPAIR ONLY**

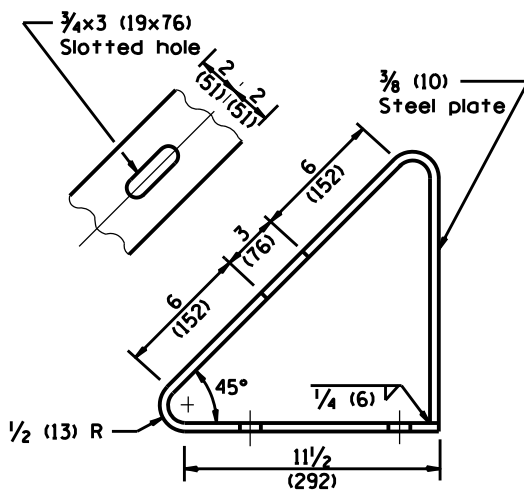
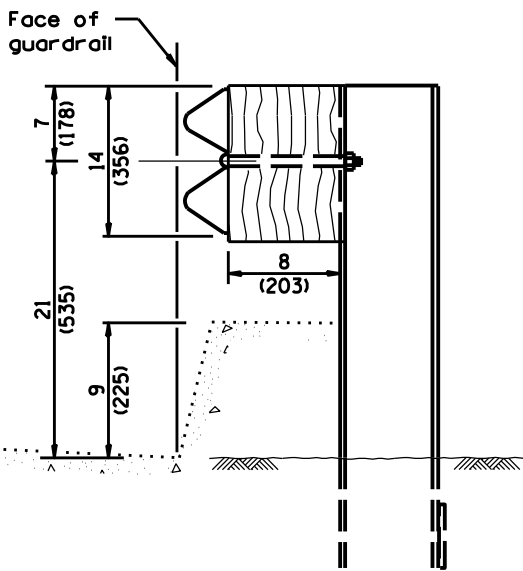
All dimensions are in millimeters (inches) unless otherwise shown.

FILE NAME =	USER NAME = \$USER\$	DESIGNED -	REVISED -	STATE OF ILLINOIS DEPARTMENT OF TRANSPORTATION	TRAFFIC BARRIER TERMINAL TYPE 4	F.A. RTE.	SECTION	COUNTY	TOTAL SHEETS	
*FILEL*		DRAWN -	REVISED -			VAR.		VAR.	43	19
	PLOT SCALE = \$SCALE\$	CHECKED -	REVISED -			CONTRACT NO. 66015				
	PLOT DATE = \$DATE\$	DATE -	REVISED -			FED. ROAD DIST. NO. ILLINOIS FED. AID PROJECT				
					SCALE: _____	SHEET NO. _____ OF _____ SHEETS	STA. _____ TO STA. _____			

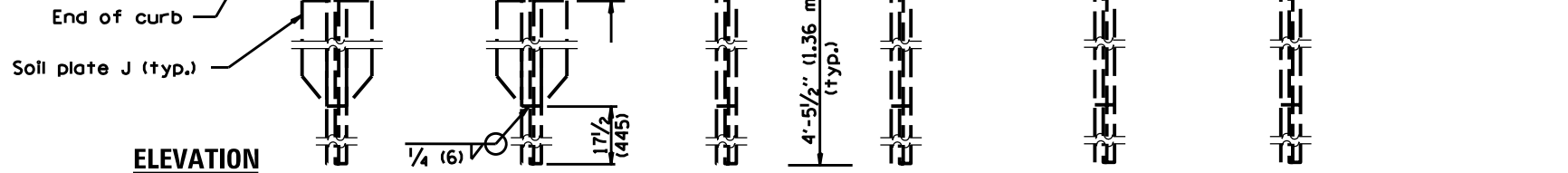
• D-3 HIGHWAY DAMAGE REPAIR 2015



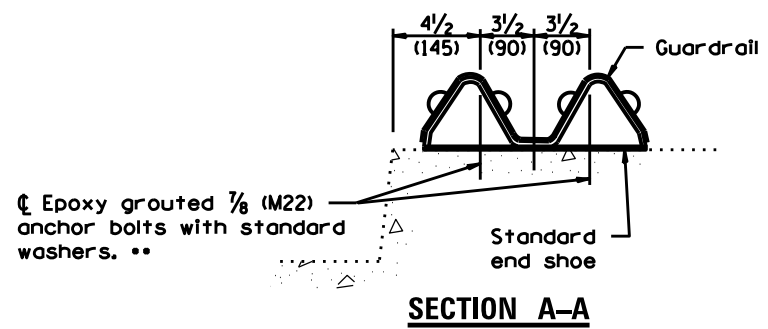
Note: Taper guardrail until it intercepts the shoulder line.



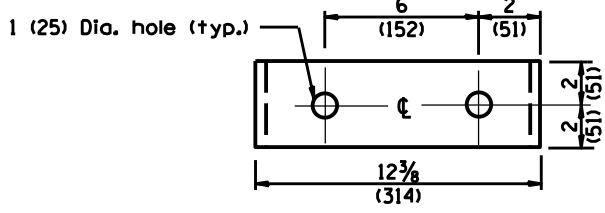
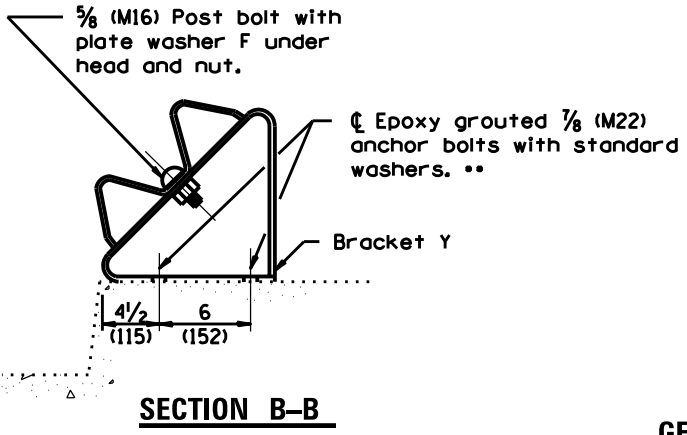
ELEVATION



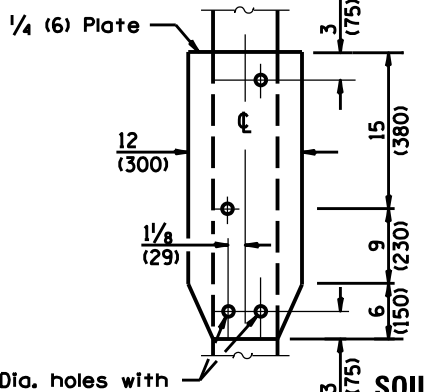
SECTION A-A



SECTION B-B



SECTION A-A

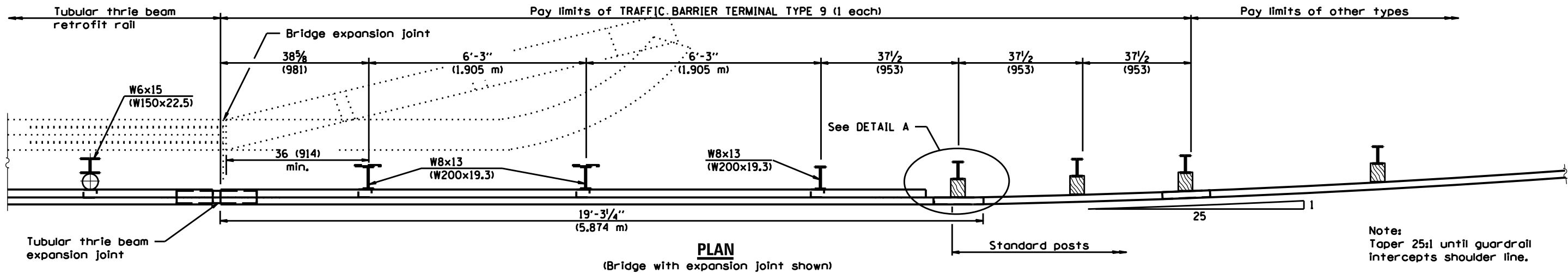


SOIL PLATE J & ALTERNATE CONNECTION DETAILS

4-3/4 (19) Dia. holes with 5/8 (M16) hex head bolts with std. hex nut (typ.)

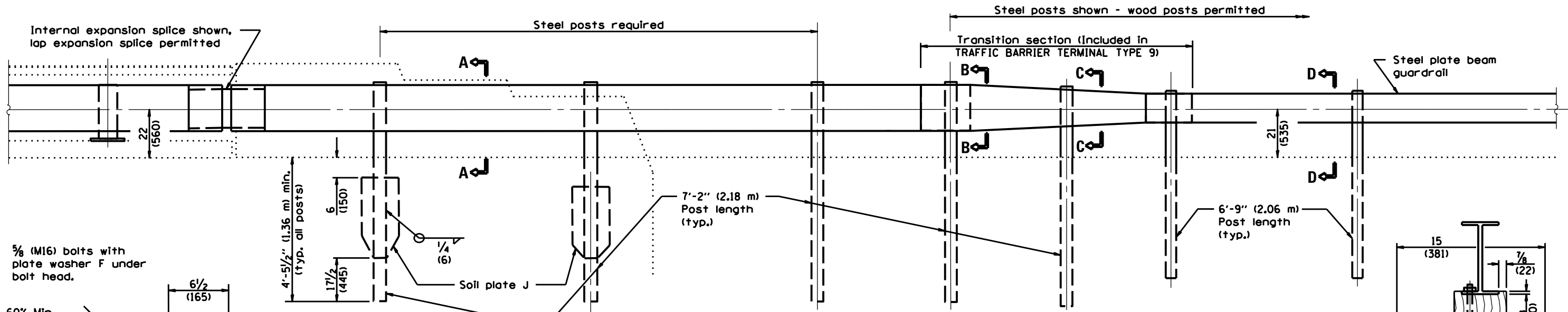
GENERAL NOTES

- See Standard 630001 for details of guardrail not shown.
- This dimension may be increased to fit field conditions. This post shall be located first. The layout of the terminal shall be determined by its location.
- After tightening, cut the anchor bolts flush with nuts, and damage the bolt head to prevent them from loosening.
- All dimensions are in inches (millimeters) unless otherwise shown.

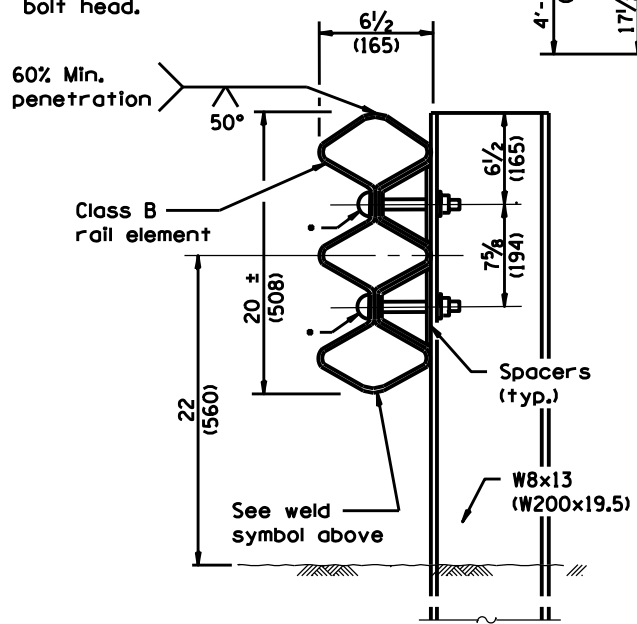


**PLAN**  
(Bridge with expansion joint shown)

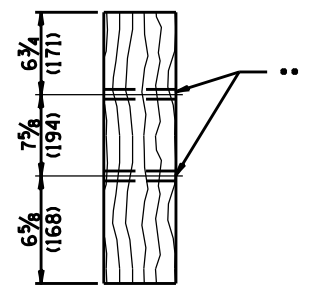
Note:  
Taper 25:1 until guardrail intercepts shoulder line.



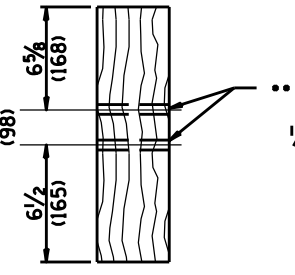
**ELEVATION**



**SECTION A-A**



**SECTION B-B**

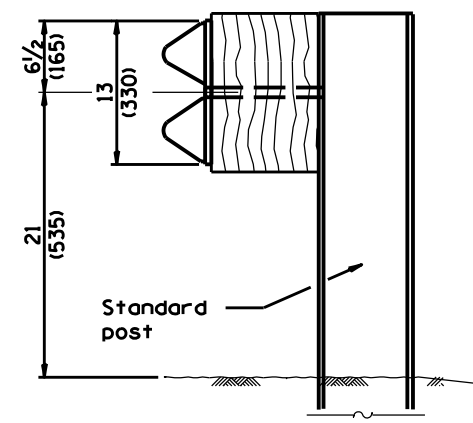


**SECTION C-C**

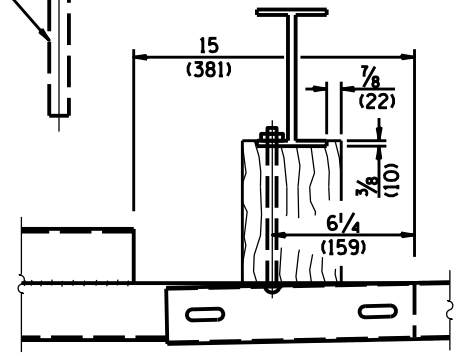
**DETAILS of BLOCK-OUTS**  
••  $\varnothing$  3/4 (19) Dia. hole

4-3/4 (19) Dia. holes with  
5/8 (M16) hex head bolts  
with std. hex nut (typ.)

**SOIL PLATE J & ALTERNATE CONNECTION DETAILS**



**SECTION D-D**



**DETAIL A**

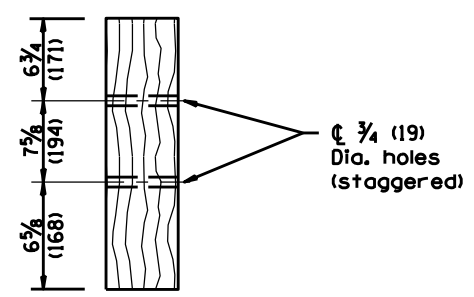
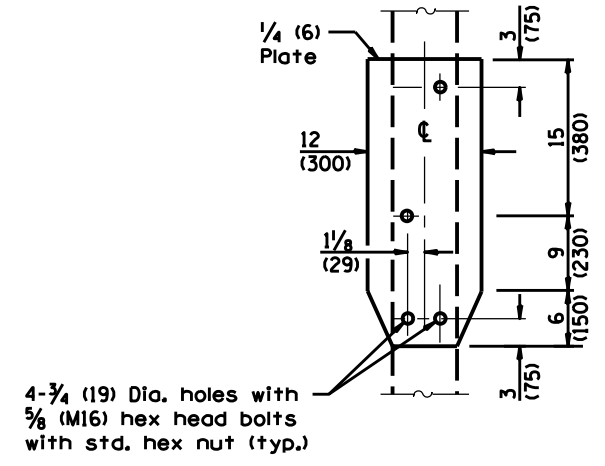
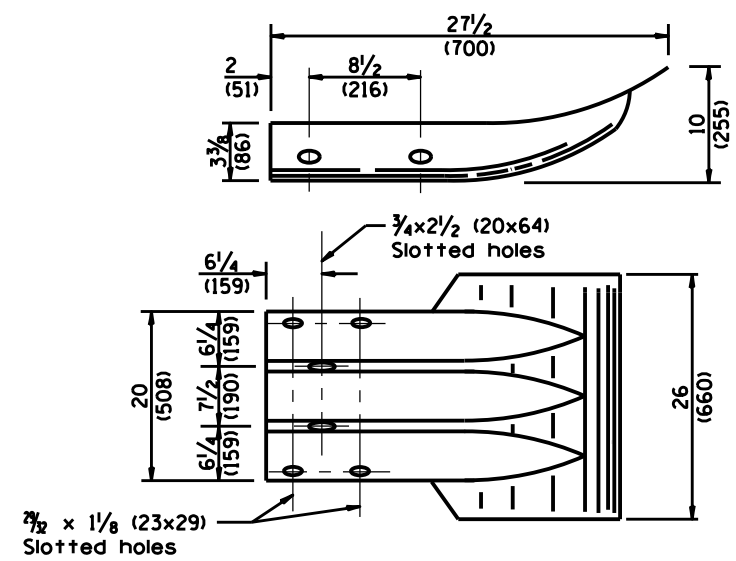
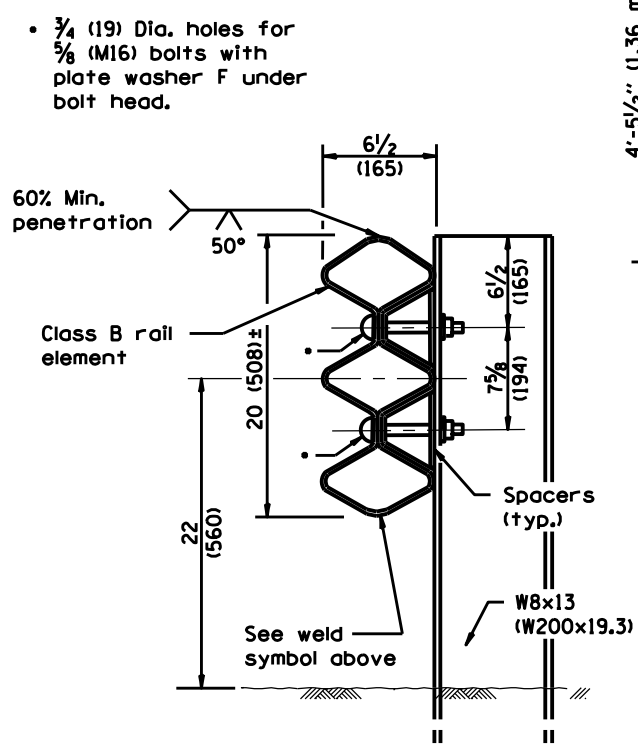
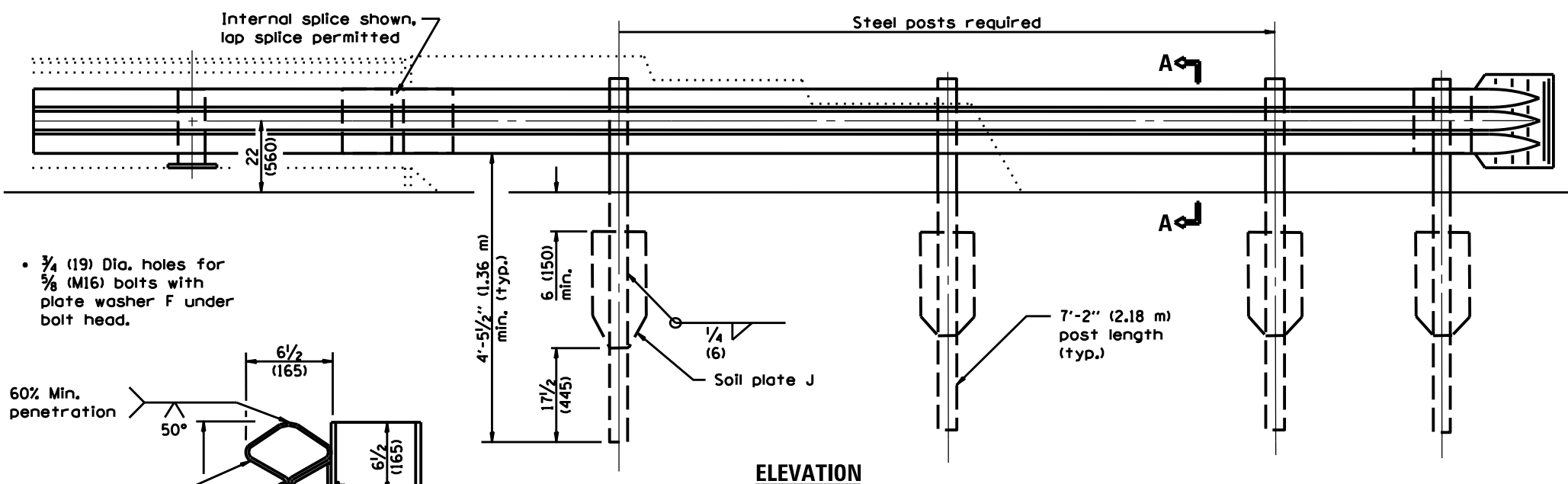
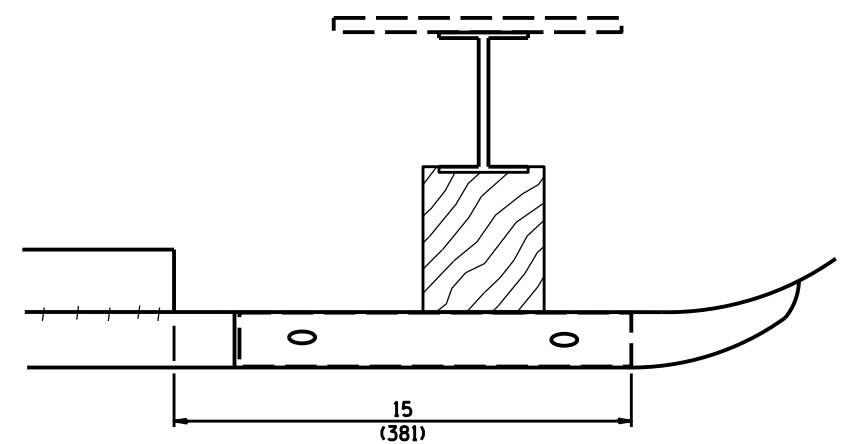
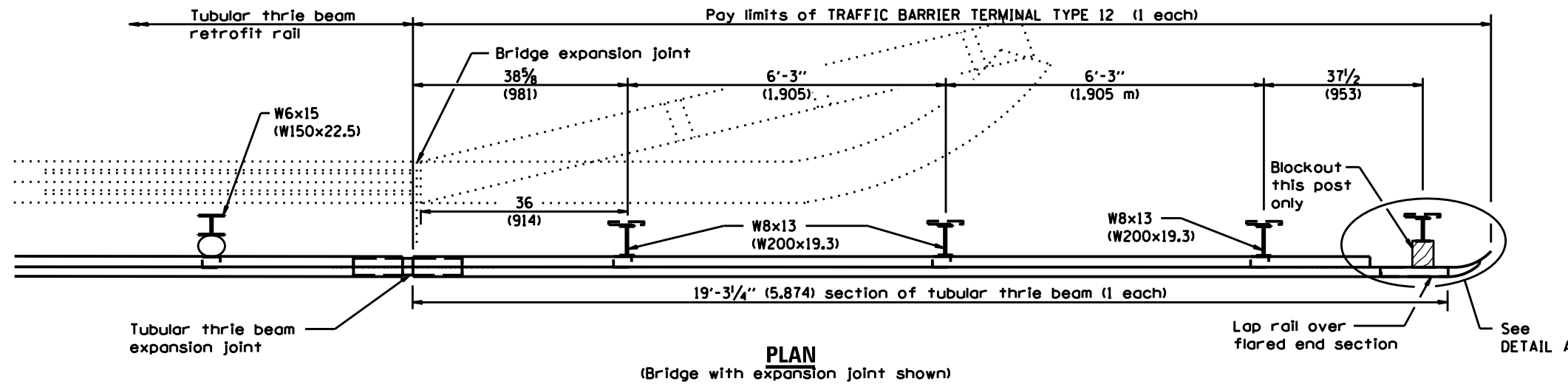
**GENERAL NOTES**

See Standards 509001 and 630001 for details of guardrail elements not shown.

The Type 9 terminal shall be installed after the posts for the bridge retrofit rail have been located as shown on Standard 509001.

All dimensions are in inches (millimeters) unless otherwise shown. • D-3 HIGHWAY DAMAGE REPAIR 2015

FILE NAME =	USER NAME = #USER#	DESIGNED -	REVISED -	STATE OF ILLINOIS DEPARTMENT OF TRANSPORTATION	TRAFFIC BARRIER TERMINAL TYPE 9		F.A. RTE.	SECTION	COUNTY	TOTAL SHEETS	SHEET NO.	
#FILE#		DRAWN -	REVISED -		SCALE: _____	SHEET _____ OF _____ SHEETS	STA. _____ TO STA. _____	VAR.		VAR.	43	21
#MODELNAME#		CHECKED -	REVISED -								CONTRACT NO. 66015	
		DATE -	REVISED -								ILLINOIS FED. AID PROJECT	



**SOIL PLATE J & ALTERNATE CONNECTION DETAILS**

**GENERAL NOTES**

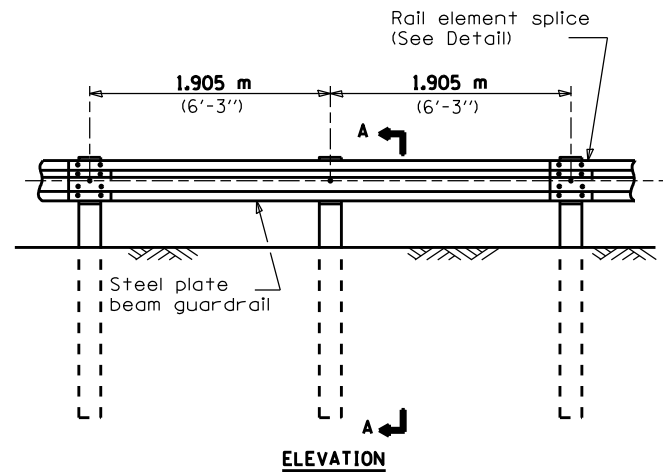
See Standard 509001 and 630001 for details of guardrail elements not shown.

The Type 12 terminal shall be installed after the posts for the bridge retrofit rail have been located as shown on Standard 509001.

All dimensions are in inches (millimeters) unless otherwise shown.

• D-3 HIGHWAY DAMAGE REPAIR 2015

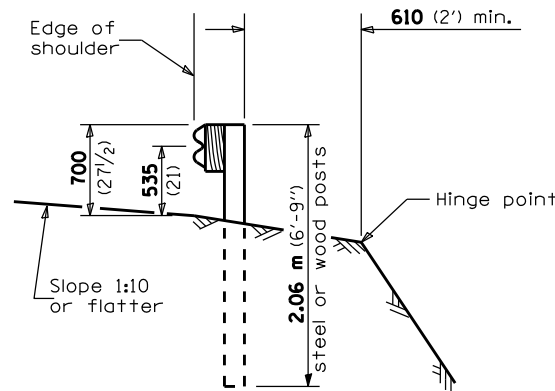
FILE NAME =	USER NAME = \$USER\$	DESIGNED -	REVISED -	STATE OF ILLINOIS DEPARTMENT OF TRANSPORTATION	TRAFFIC BARRIER TERMINAL TYPE 12		F.A. RTE.	SECTION	COUNTY	TOTAL SHEETS	SHEET NO.		
*FILEL\$		DRAWN -	REVISED -		SCALE:	SHEET	OF	SHEETS	STA.	TO STA.	VAR.	43	22
*MODELNAME\$		CHECKED -	REVISED -		CONTRACT NO. 66015								
		DATE	REVISED		ILLINOIS FED. AID PROJECT								



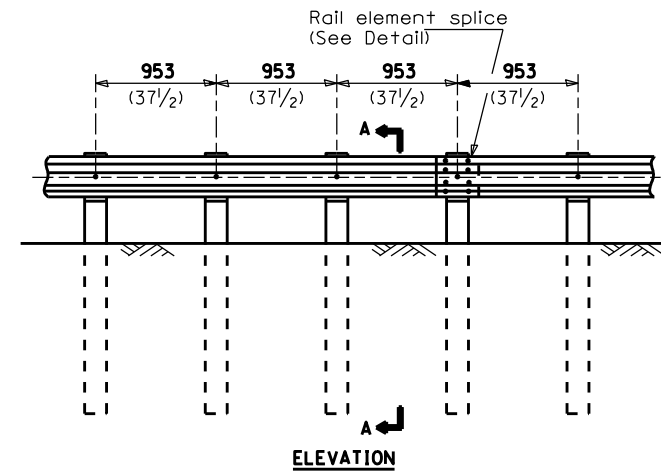
ELEVATION

**TYPE A**

1.905 m (6'-3") Typical post spacing



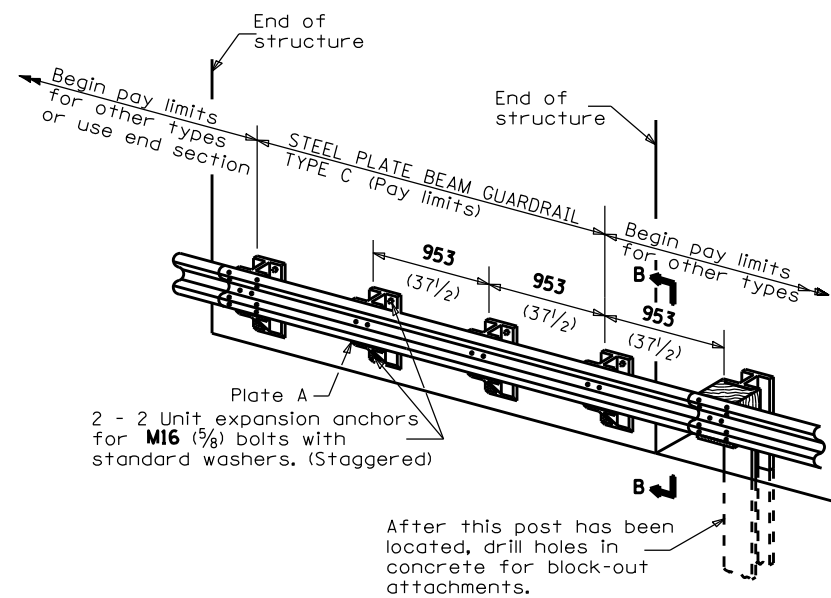
SECTION A-A



ELEVATION

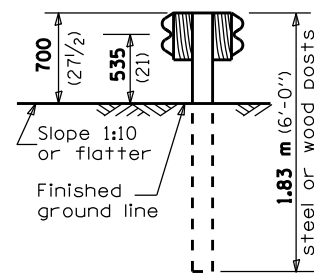
**TYPE B**

953 (37 1/2) Closed post spacing

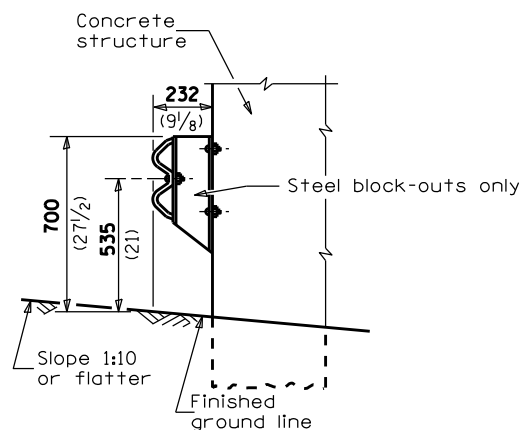


**TYPE C**

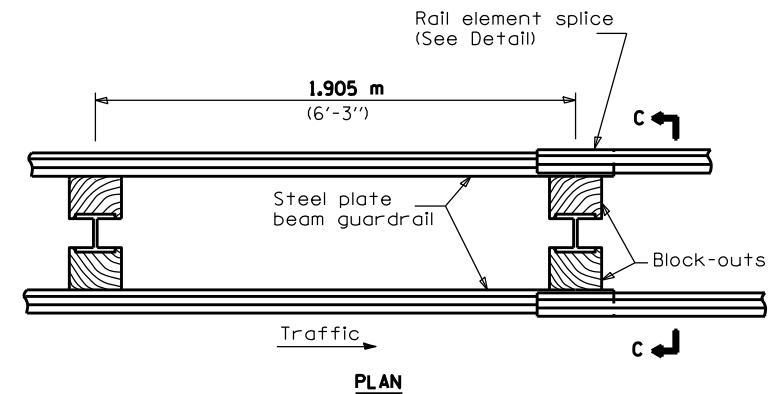
953 (37 1/2) Block-out spacing



SECTION C-C



SECTION B-B



PLAN

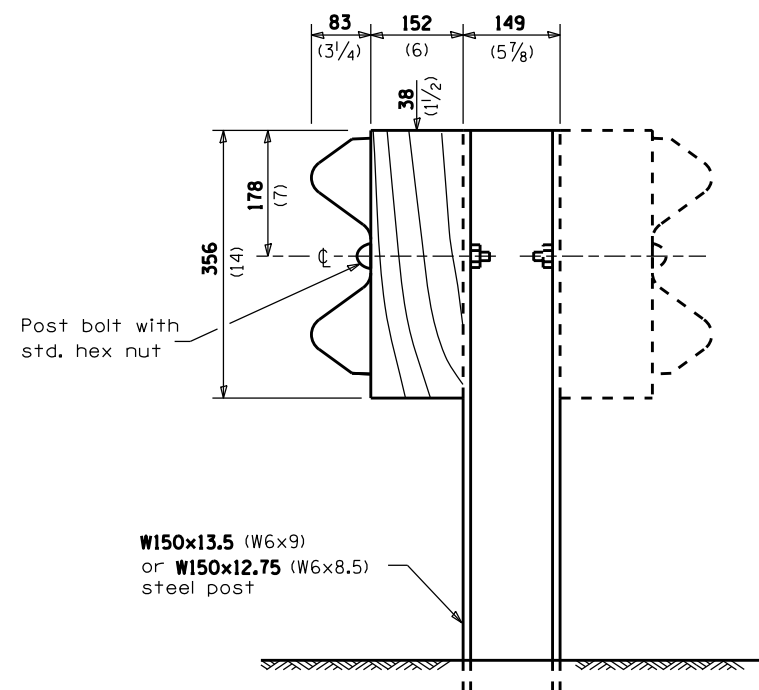
**TYPE D**

Double steel plate beam guardrail  
1.905 m (6'-3") typical post spacing

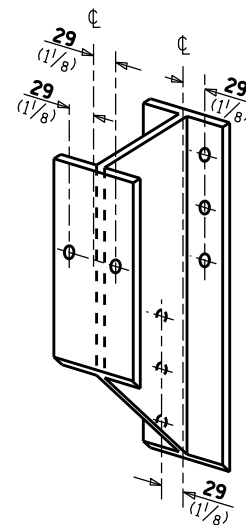
**GENERAL NOTES**

All slope ratios are expressed as units of vertical displacement to units of horizontal displacement (V:H).  
All dimensions are in millimeters (inches) unless otherwise shown.

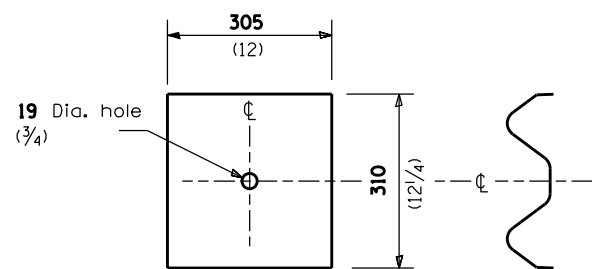
FILE NAME = *FILE*	USER NAME = *USER*	DESIGNED - DRAWN -	REVISED - REVISED -	STATE OF ILLINOIS DEPARTMENT OF TRANSPORTATION	PRE-MGS EFFECTIVE 4-1-06 STEEL PLATE BEAM GUARDRAIL STANDARD 630001-06 (Sheet 1 of 4)	F.A. RTE. SECTION COUNTY TOTAL SHEETS SHEET NO.
	PLOT SCALE = *SCALE*	CHECKED - DATE -	REVISED - REVISED -		SCALE: SHEET NO. OF SHEETS STA. TO STA.	Y&B. * Y&B. 43 23
	PLOT DATE = *DATE*					FED. ROAD DIST. NO. ILLINOIS FED. AID PROJECT
CONTRACT NO. 66015						



**STEEL POST CONSTRUCTION**



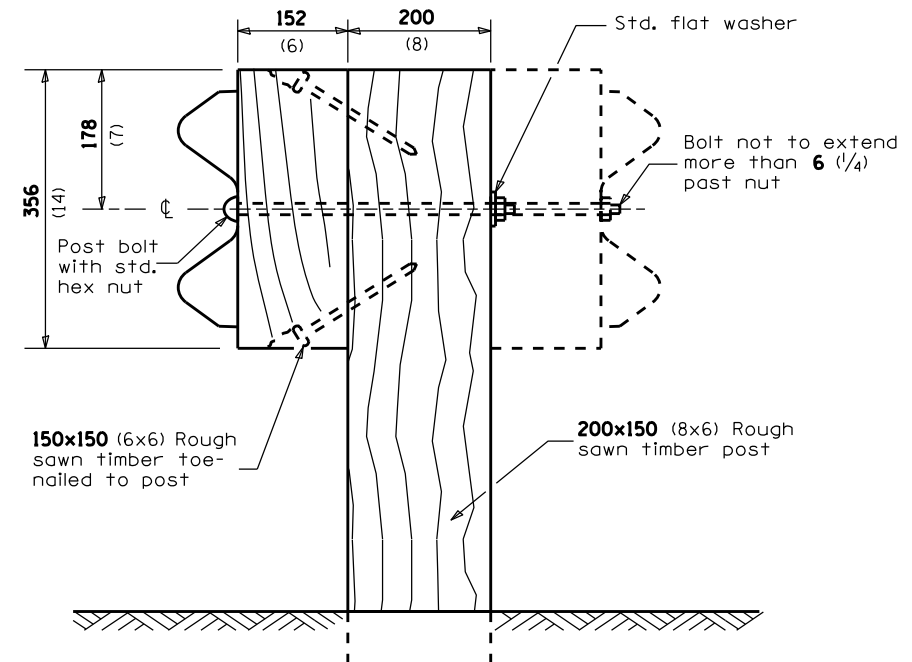
**STEEL BLOCK-OUT DETAIL**



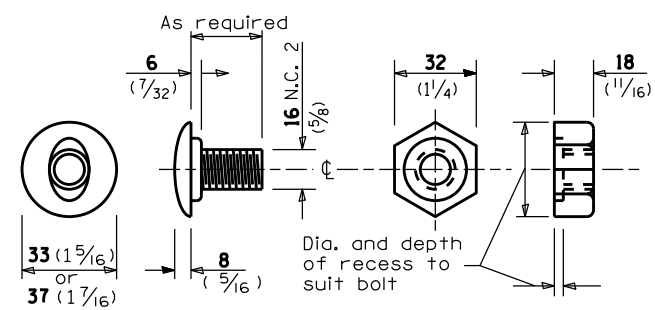
**NOTE**

Plate A shall be placed between rail element and block-out at non-splice mounting points only when steel block-outs are used.

**PLATE A**



**WOOD POST CONSTRUCTION**

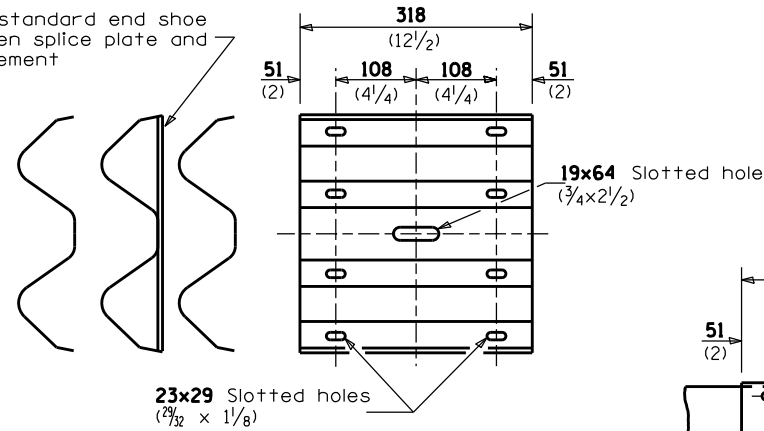


**POST OR SPLICE BOLT & NUT**

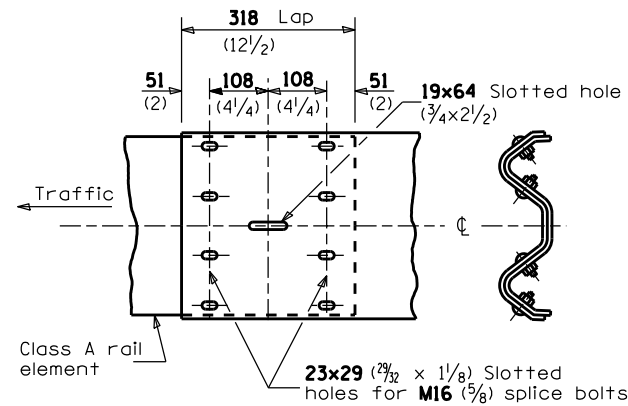
FILE NAME = *FILEL*	USER NAME = *USER*	DESIGNED - ___	REVISED - ___	<b>STATE OF ILLINOIS DEPARTMENT OF TRANSPORTATION</b>	<b>PRE-MGS EFFECTIVE 4-1-06 STEEL PLATE BEAM GUARDRAIL STANDARD 630001-06</b> <small>(Sheet 2 of 4)</small>	F.A. RTE. _____	SECTION _____	COUNTY _____	TOTAL SHEETS _____	SHEET NO. _____	
	PLOT SCALE = *SCALE*	DRAWN - ___	REVISED - ___			VAR. _____	_____	_____	43	24	
	PLOT DATE = *DATE*	CHECKED - ___	REVISED - ___			CONTRACT NO. 66015					
		DATE - ___	REVISED - ___			SCALE: _____ SHEET NO. ___ OF ___ SHEETS STA. _____ TO STA. _____		FED. ROAD DIST. NO. _____ ILLINOIS FED. AID PROJECT			



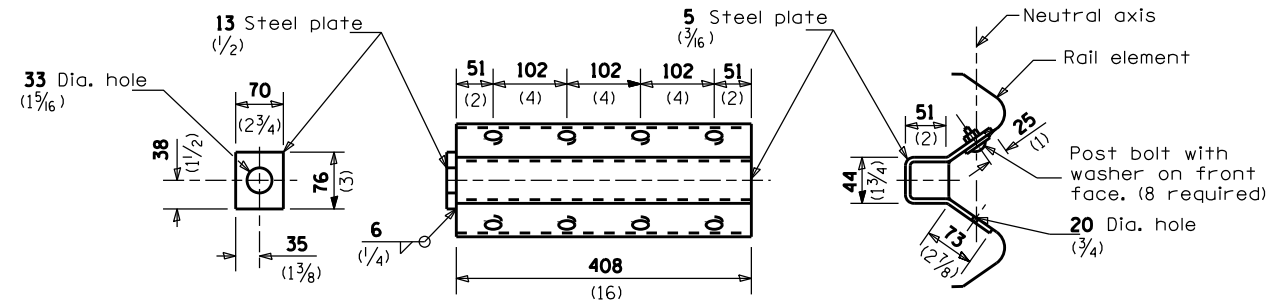
Place standard end shoe between splice plate and rail element



**SPLICE PLATE**

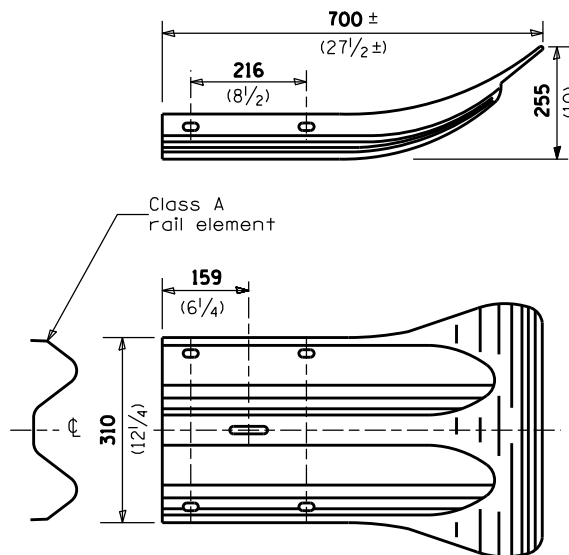


**RAIL ELEMENT SPLICE**

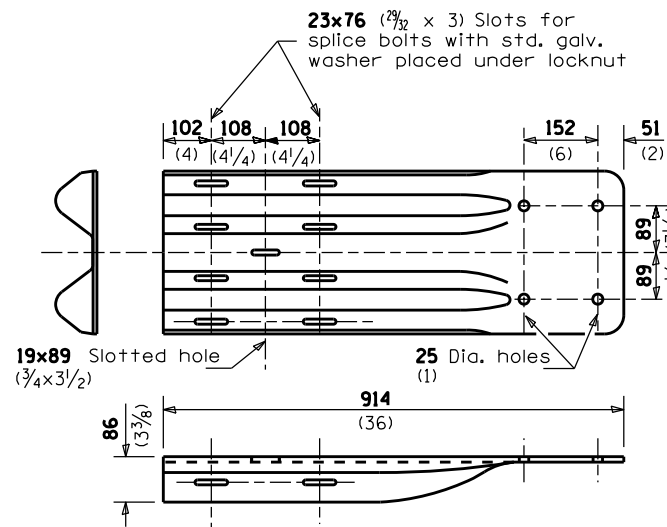


**NOTE**  
Anchor plate T shall be used to attach cable assembly to guardrail when required on traffic barrier terminals.

**ANCHOR PLATE T DETAILS**

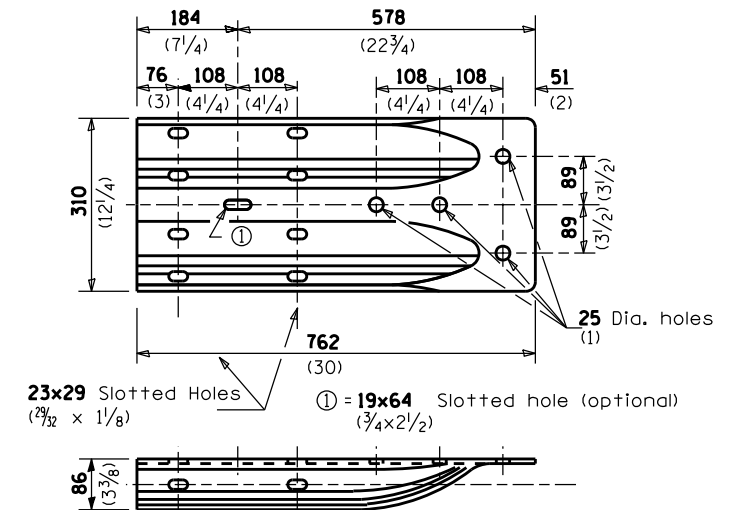


**END SECTION**



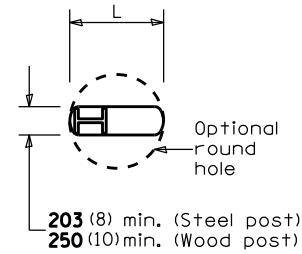
**NOTE**  
When end shoe is attached to a bridge parapet which has an expansion joint, the bolts shall be provided with a locknut or double nut and shall be tightened only to a point that will allow guardrail movement.  
The standard end shoe shall be attached to the concrete with pre-drilled or self-drilling anchor bolts. The anchor cone shall be set flush with the surface of the concrete.  
Externally threaded studs protruding from the surface of the concrete will not be permitted.

**END SHOE**

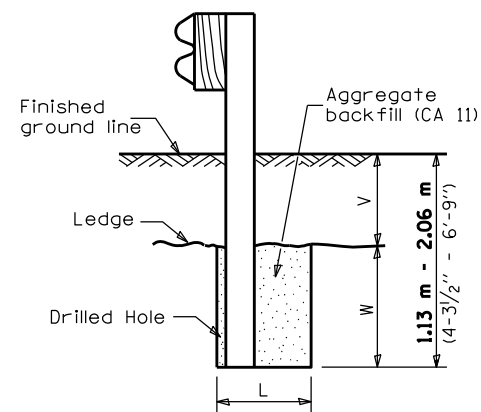


**ALTERNATE END SHOE**

FILE NAME =	USER NAME = \$USER*	DESIGNED -	REVISED -	STATE OF ILLINOIS DEPARTMENT OF TRANSPORTATION	PRE-MGS EFFECTIVE 4-1-06 STEEL PLATE BEAM GUARDRAIL STANDARD 630001-06 (Sheet 3 of 4)	F.A. RTE.	SECTION	COUNTY	TOTAL SHEETS	SHEET NO.	
*FILEL*		DRAWN -	REVISED -			VAR.		VAR.	43	25	
PLOT SCALE = \$SCALE*		CHECKED -	REVISED -			CONTRACT NO. 66015					
PLOT DATE = \$DATE*		DATE -	REVISED -			FED. ROAD DIST. NO. ILLINOIS FED. AID PROJECT					
				SCALE: _____ SHEET NO. _____ OF _____ SHEETS STA. _____ TO STA. _____							



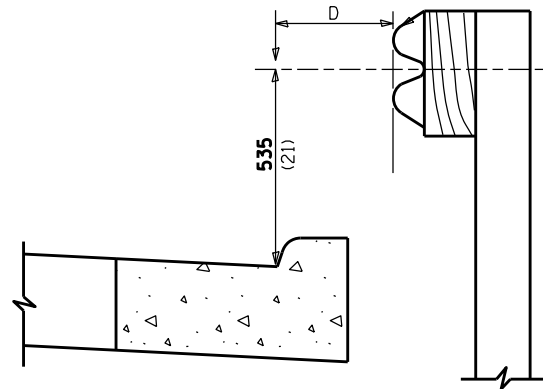
**PLAN**



Note:  
Ledge line is top of rock ledge or hard slag fill.

**ELEVATION**

**FOOTING FOR POST WHEN IMPERVIOUS MATERIAL IS ENCOUNTERED**

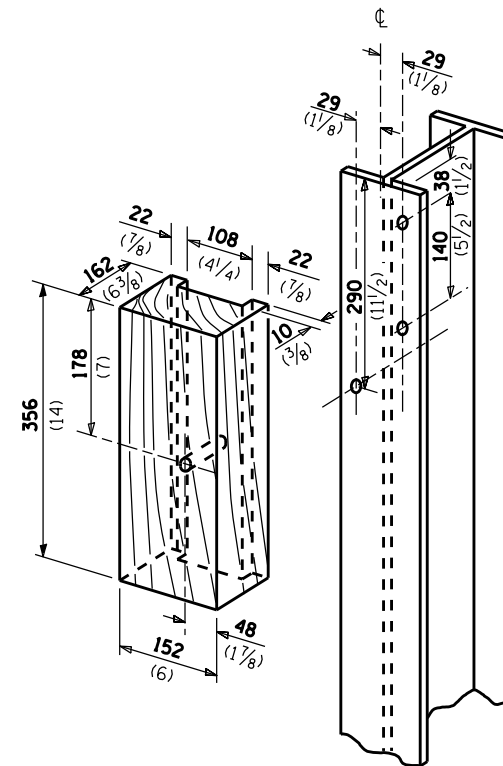


Note:

If it is necessary for D to be more than 300 (12) and less than 3.0 m (10'-0") type M-5 (M-2) curb and gutter (Std. 606001) shall be used in front of and in advance of the guardrail.

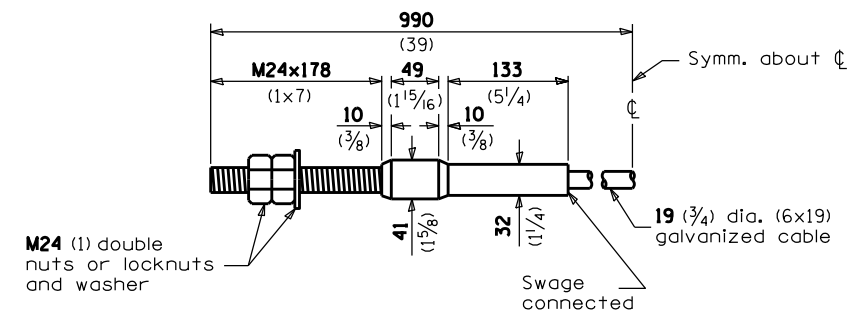
**GUARDRAIL PLACED BEHIND CURB**

(D = 0 desirable to 300 (12) maximum)



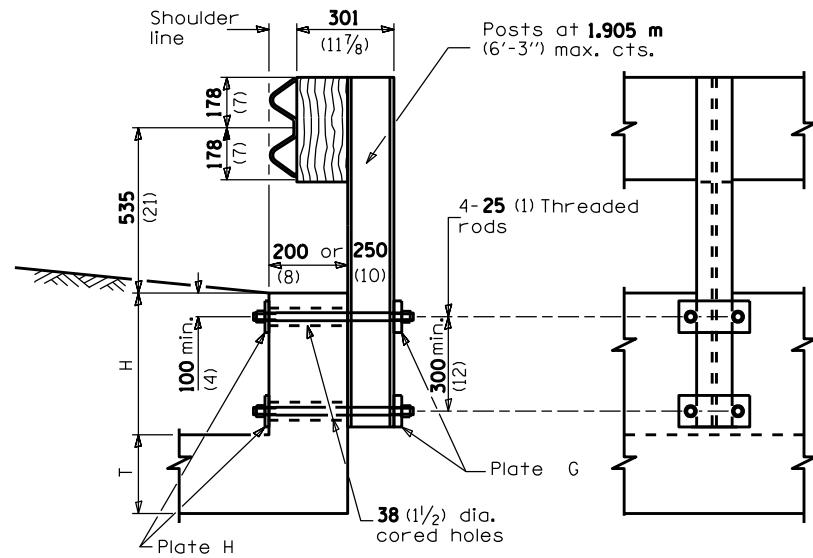
**WOOD BLOCK-OUT AND STEEL POST DETAILS**

V	W	L	
		Steel Post	Wood Post
0 - 460 (0 - 18)	610 (24)	530 (21)	580 (23)
>460 - 825 (>18 - 41.5)	305 (12)	203 (8)	250 (10)
>825 - 1.13 m (>41.5 - 53.5)	305 - 0 (12 - 0)	203 (8)	250 (10)



**CABLE ASSEMBLY**

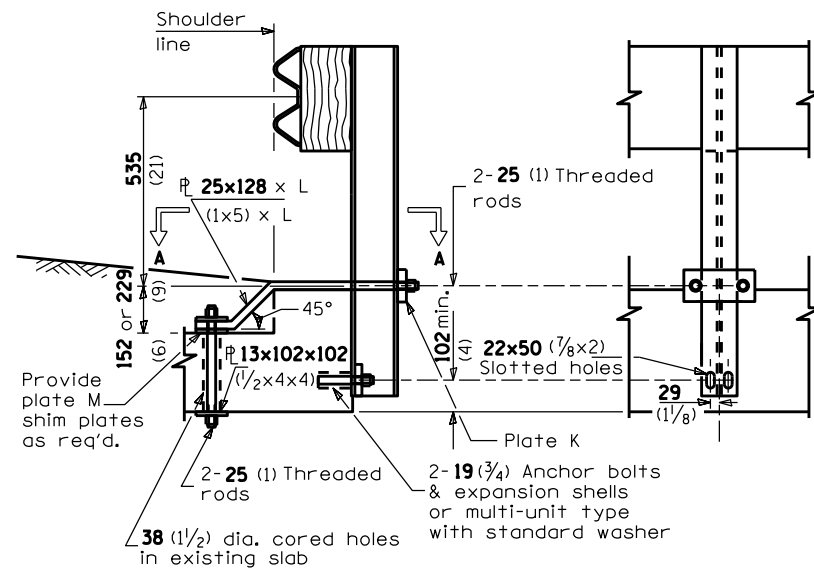
(18,100 kg (40,000 lbs.) min. breaking strength)  
Tighten to taut tension.



**CROSS SECTION**

**ELEVATION**

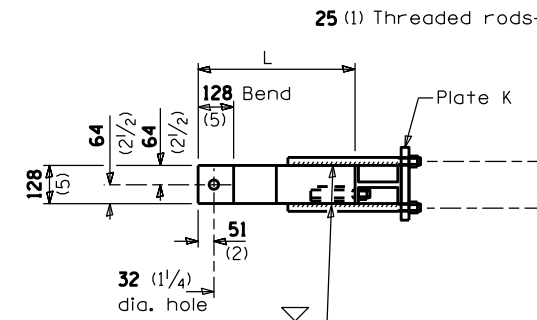
**CONDITION H > 450 (18)**



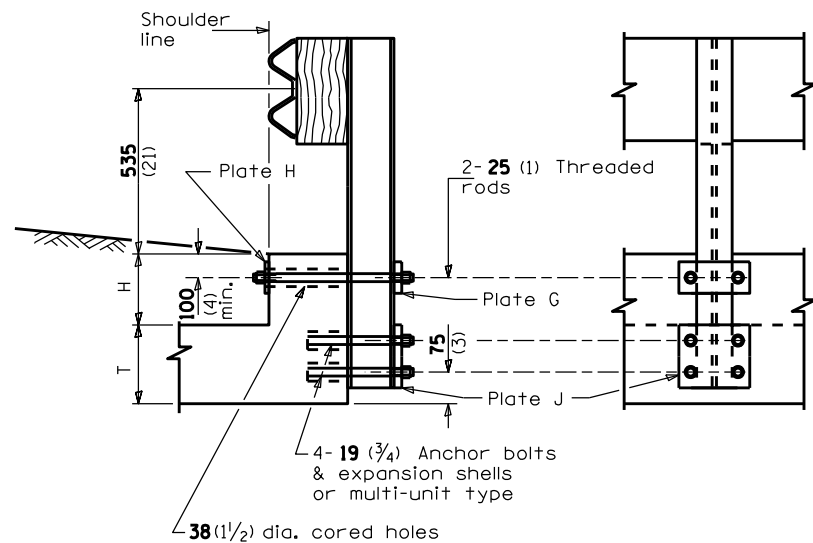
**CROSS SECTION**

**ELEVATION**

**CASE II  
MOUNTED ON TOP HEADWALL  
WITH SQUARE TIP**



**SECTION A-A**

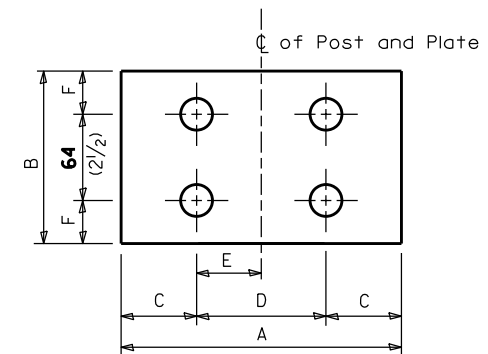


**CROSS SECTION**

**ELEVATION**

**CONDITION H < 450 (18) & H+T ≥ 510 (20)**

**CASE I  
MOUNTED ON  
RAISED HEADWALL**



**PLATE TYPE J**

PLATE DIMENSIONS								
Type	A	B	C	D	E	F	Hole Dia.	Thick-ness
G	230 (9)	100 (4)	40 (1 1/2)	150 (6)	75 (3)	50 (2)	29 (1 1/8)	25 (1)
H	230 (9)	100 (4)	40 (1 1/2)	150 (6)	75 (3)	50 (2)	29 (1 1/8)	13 (1/2)
J	230 (9)	126 (5)	40 (1 1/2)	150 (6)	75 (3)	31 (1 1/4)	22 (7/8)	25 (1)
K	230 (9)	100 (4)	40 (1 1/2)	150 (6)	75 (3)	50 (2)	29 (1 1/8)	32 (1 1/4)
M	100 (4)	100 (4)	50 (2)	N/A	N/A	50 (2)	32 (1 1/8)	13 (1/2)

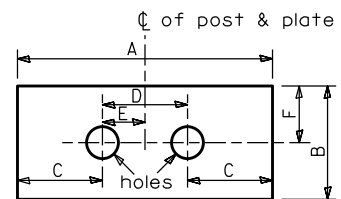
**GENERAL NOTES**

Except as noted, dimensions and notes specified for case II, III, and IV are the same as specified for case I.

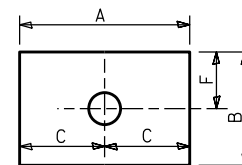
For details of guardrail elements not shown, see Standard 630001.

All threaded rods shall be installed with heavy hex nuts and standard washers.

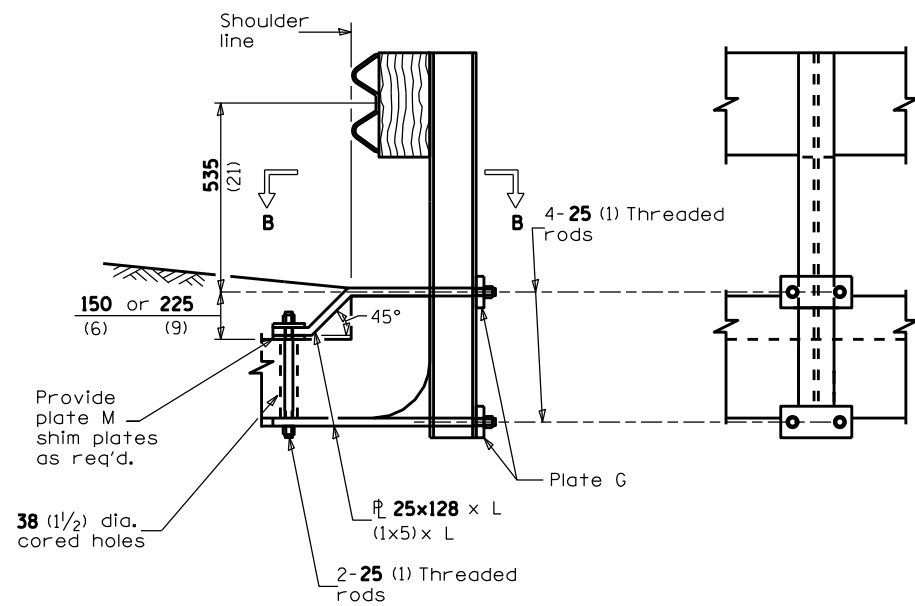
All dimensions are in millimeters (inches) unless otherwise shown.



**PLATE TYPES G, H & K**

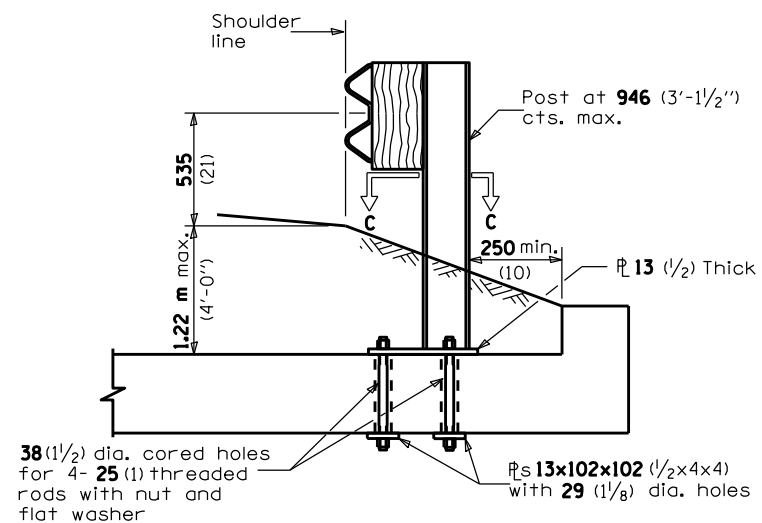


**PLATE TYPE M**

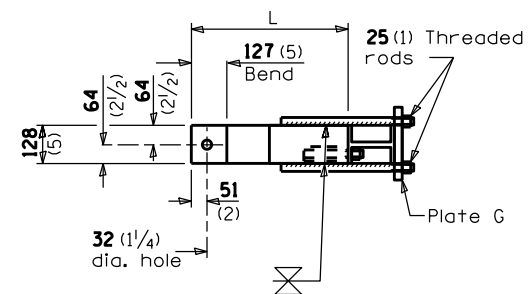


**CROSS SECTION**

**ELEVATION**

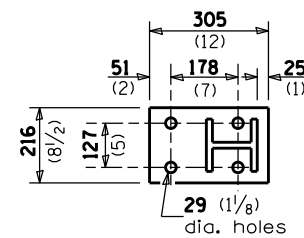


**CROSS SECTION**



**SECTION B-B**

**CASE III  
MOUNTED ON HEADWALL  
WITH CURVED OR DEMOLISHED TIP**



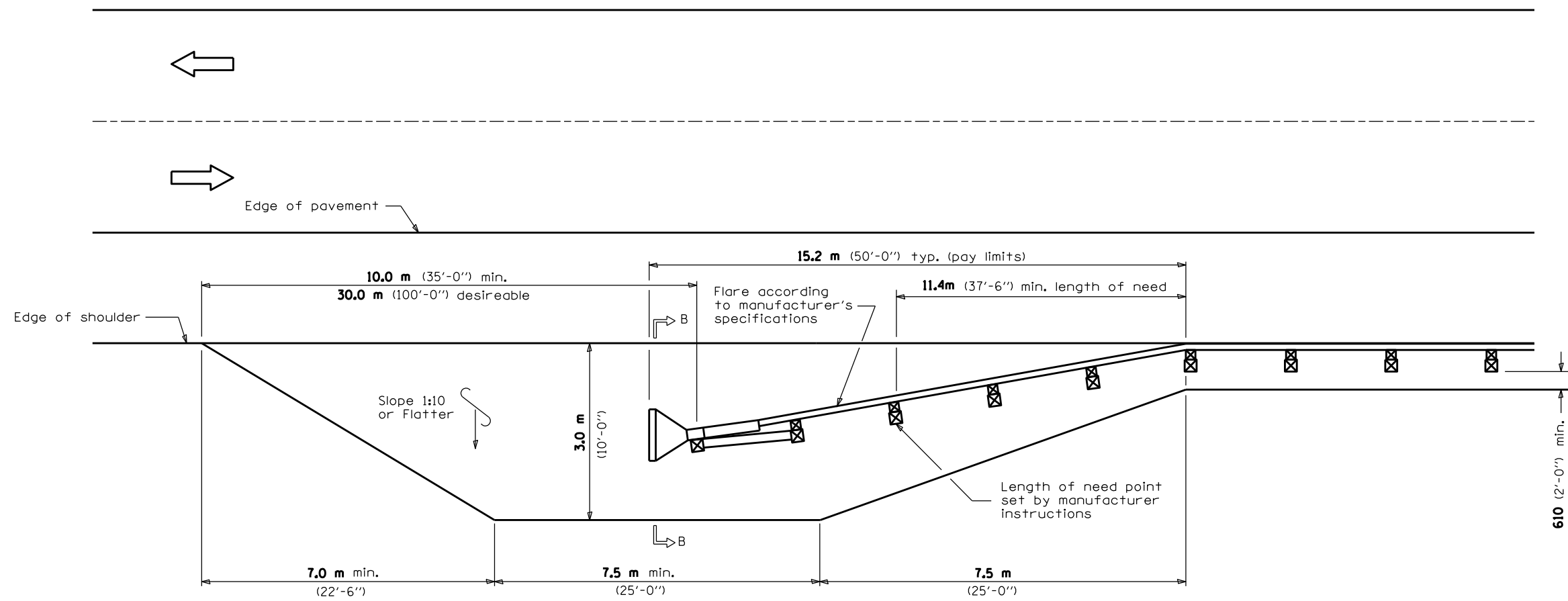
**SECTION C-C**

**CASE IV  
MOUNTED ON SLAB**

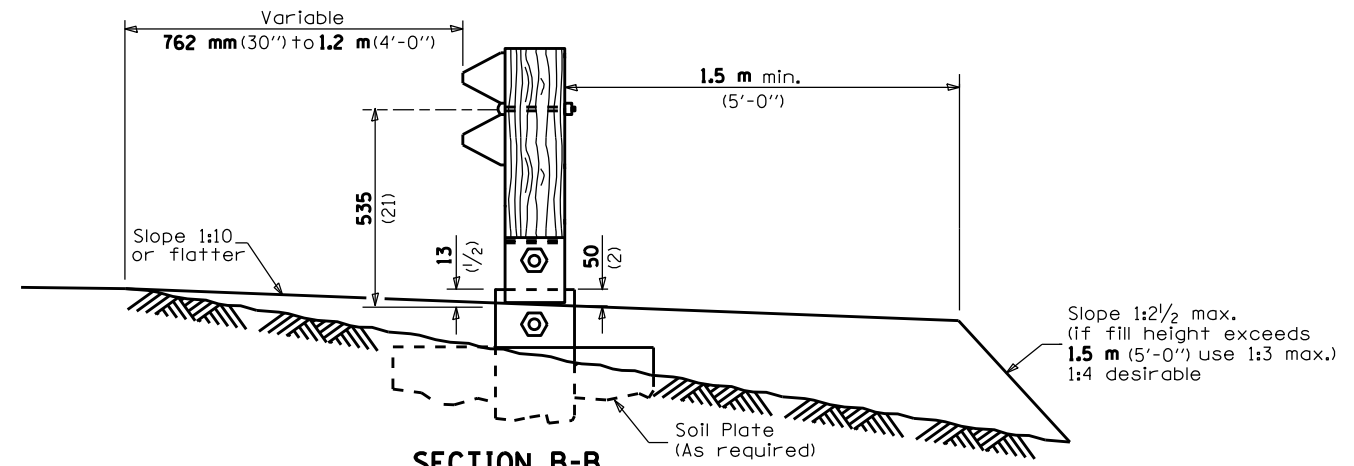
All dimensions are in millimeters (inches) unless otherwise shown.

FILE NAME = *FILEL*	USER NAME = *USER*	DESIGNED -	REVISED -	STATE OF ILLINOIS DEPARTMENT OF TRANSPORTATION	PRE-MGS EFFECTIVE 4-1-06 GUARDRAIL MOUNTED ON EXISTING CULVERTS STANDARD 630101-06 (Sheet 2 of 2)	F.A. RTE.	SECTION	COUNTY	TOTAL SHEETS	SHEET NO.	
	PLOT SCALE = *SCALE*	DRAWN -	REVISED -			Y&B.		Y&B.	43	28	
	PLOT DATE = *DATE*	CHECKED -	REVISED -			CONTRACT NO. 66015					
		DATE -	REVISED -			FED. ROAD DIST. NO. ILLINOIS FED. AID PROJECT					





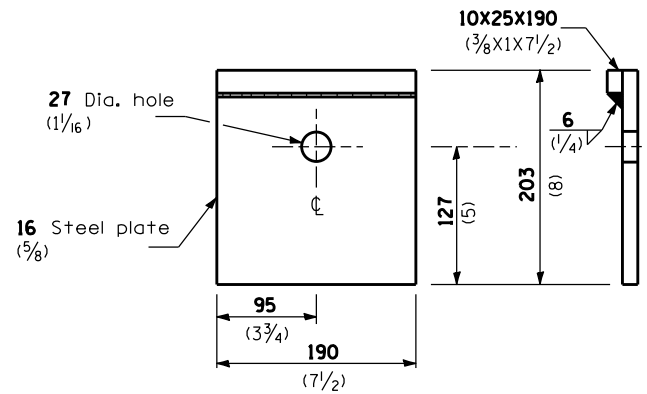
**SHOULDER WIDENING TRANSITION  
FOR FLARED TERMINAL**



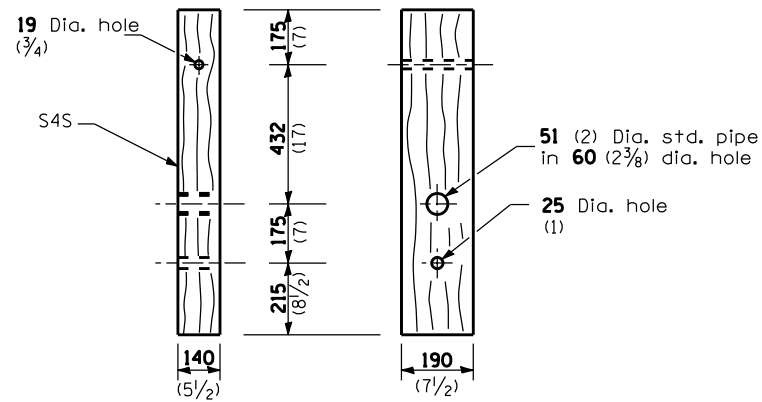
**SECTION B-B**  
(End section omitted for clarity.)

• D-3 HIGHWAY DAMAGE REPAIR 2015

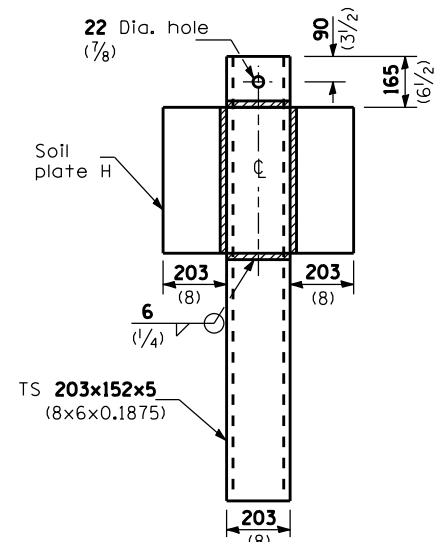
FILE NAME = *FILEL*	USER NAME = *USER*	DESIGNED - ___	REVISED - ___	<b>STATE OF ILLINOIS DEPARTMENT OF TRANSPORTATION</b>	PRE-MGS EFFECTIVE 4-1-06 <b>SHOULDER WIDENING FOR TYPE 1 (SPECIAL) GUARDRAIL TERMINALS</b> STANDARD 630301-03 (Sheet 2 of 2)		F.A. RTE.	SECTION	COUNTY	TOTAL SHEETS	SHEET NO.	
	PLOT SCALE = *SCALE*	DRAWN - ___	REVISED - ___		SCALE: _____	SHEET NO. ___ OF ___ SHEETS	STA. _____ TO STA. _____	VAR.	VAR.	VAR.	43	30
	PLOT DATE = *DATE*	CHECKED - ___	REVISED - ___									
		DATE - _____	REVISED - ___					FED. ROAD DIST. NO. _____	ILLINOIS FED. AID PROJECT			CONTRACT NO. 66015



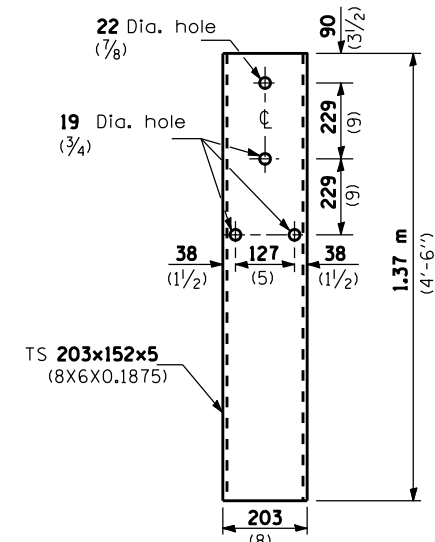
**BEARING PLATE K**



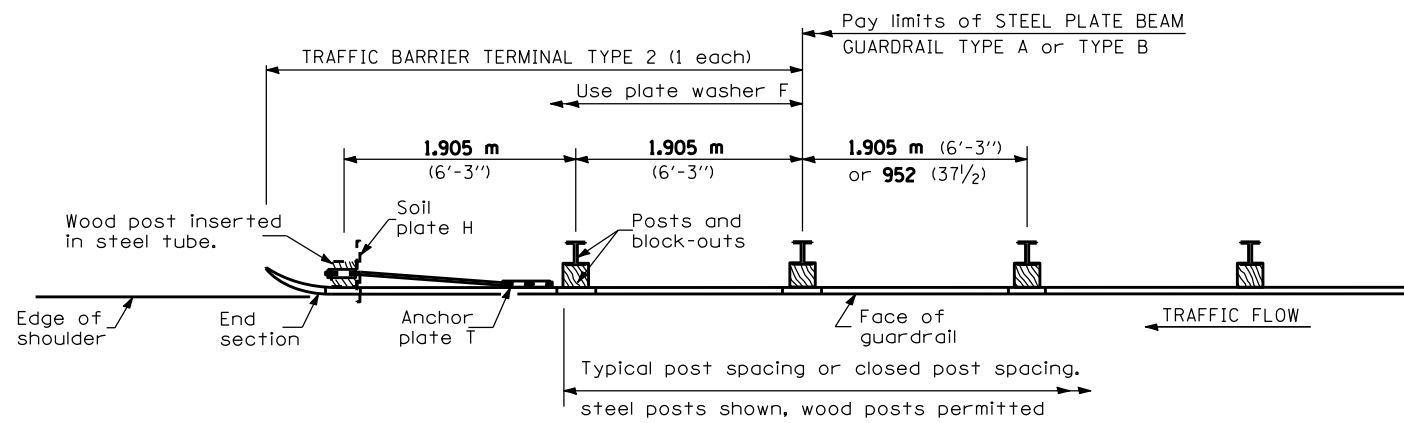
**WOOD POST**



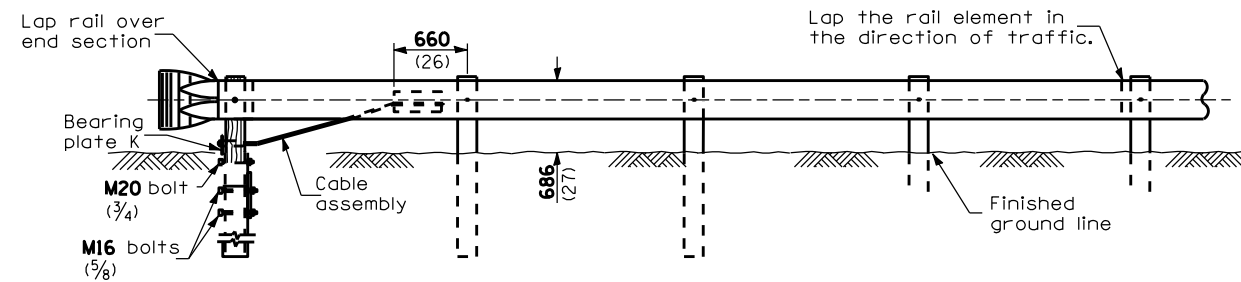
**ALTERNATE SOIL PLATE CONNECTION**



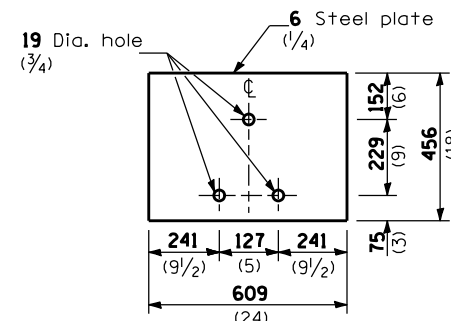
**STEEL TUBE**



**PLAN**



**ELEVATION**



**SOIL PLATE H**

**GENERAL NOTES**

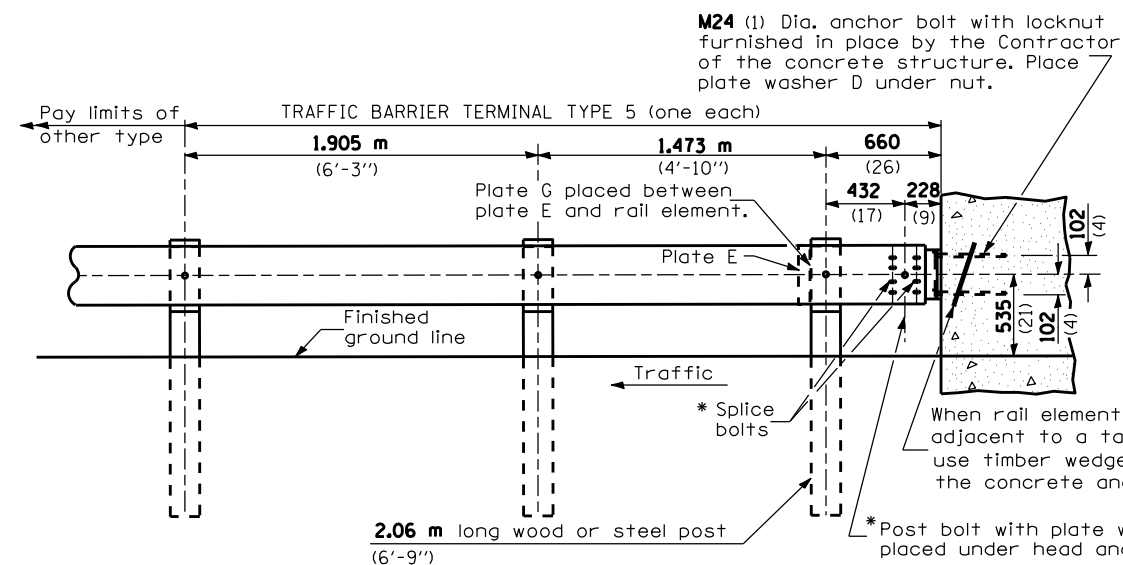
See Standard 630001 for details of guardrail not shown.

Use plate washer F at all posts.

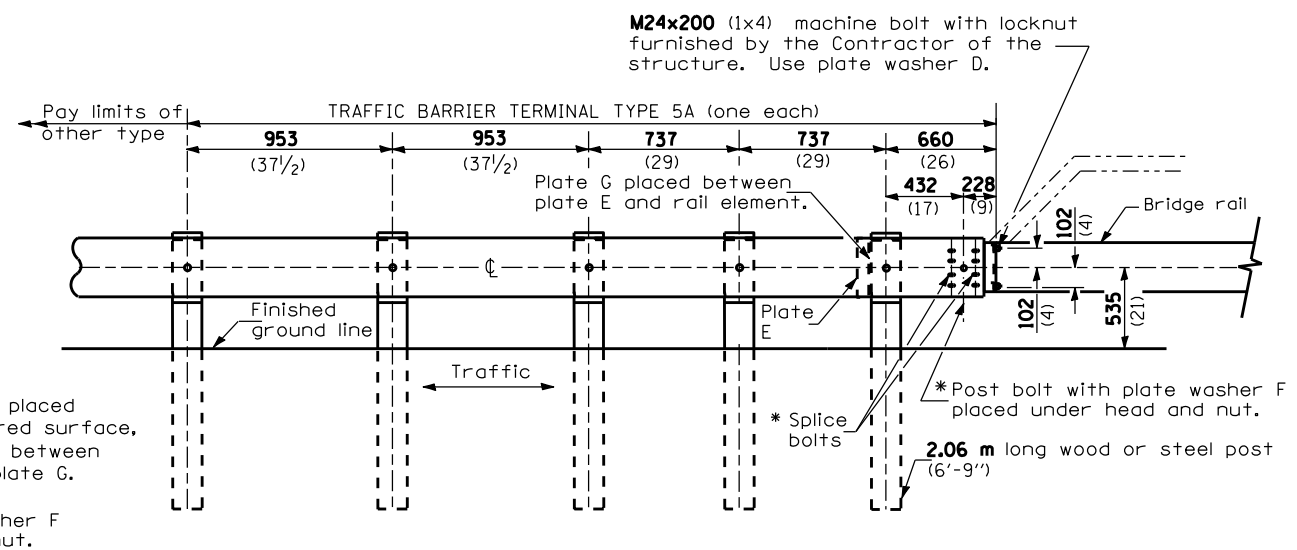
The bearing plate K shall be held in position by (2) two eight penny nails driven into the post and bent over the top of the plate.

All dimensions are in millimeters (inches) unless otherwise shown.

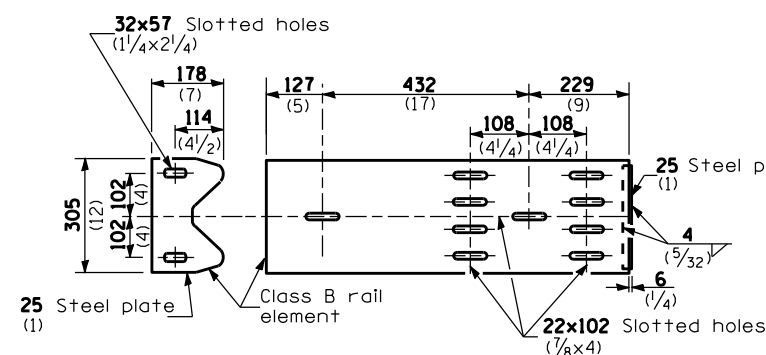
FILE NAME =	USER NAME = \$USER*	DESIGNED -	REVISED -	STATE OF ILLINOIS DEPARTMENT OF TRANSPORTATION	PRE-MGS EFFECTIVE 4-1-06 TRAFFIC BARRIER TERMINAL TYPE 2 STANDARD 631011-02	F.A. RTE.	SECTION	COUNTY	TOTAL SHEETS	SHEET NO.	
*FILEL*		DRAWN -	REVISED -			Y&B.		Y&B.	43	31	
PLOT SCALE = *SCALE*		CHECKED -	REVISED -			CONTRACT NO. 66015					
PLOT DATE = \$DATE*		DATE -	REVISED -			FED. ROAD DIST. NO. ILLINOIS FED. AID PROJECT					



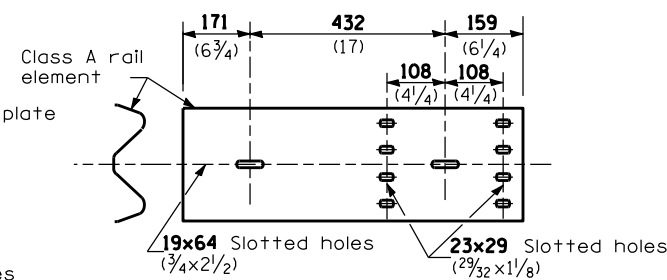
**TYPE 5 - CONCRETE BRIDGE PARAPET**



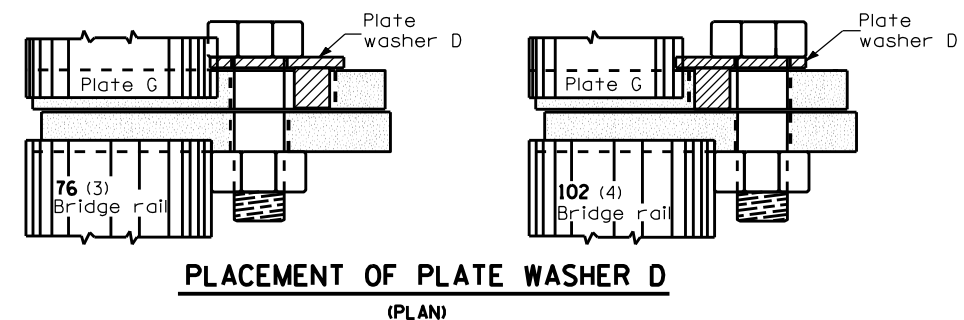
**TYPE 5A - STEEL BRIDGE RAIL**



**PLATE G**



**PLATE E**



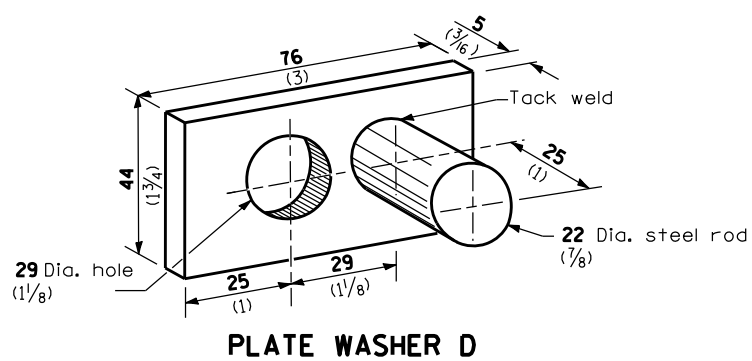
**GENERAL NOTES**

Install plate washer D so that the 25 mm (1") projection fills the remainder of the slotted holes in the 25 mm (1") end plate on plate G after the M24 (1") dia. bolts are in place.

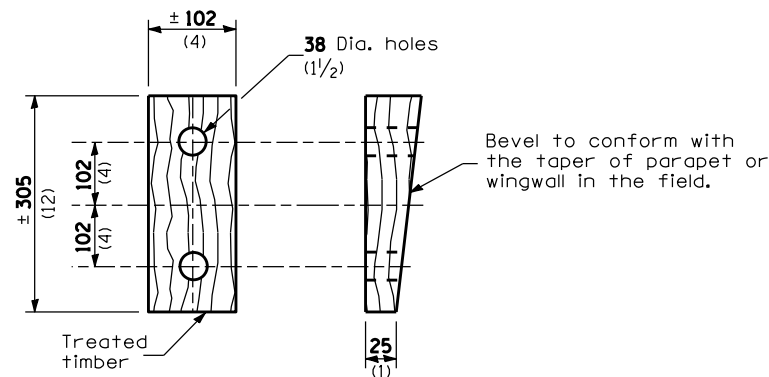
\* Bolts shall be provided with locknut or double nut and shall be tightened only to a point that will allow plate G to be free to move when an expansion joint exists below the connector.

See Standard 630001 for details of guardrail not shown.

All dimensions are in millimeters (inches) unless otherwise shown.



**PLATE WASHER D**



**WEDGE M**

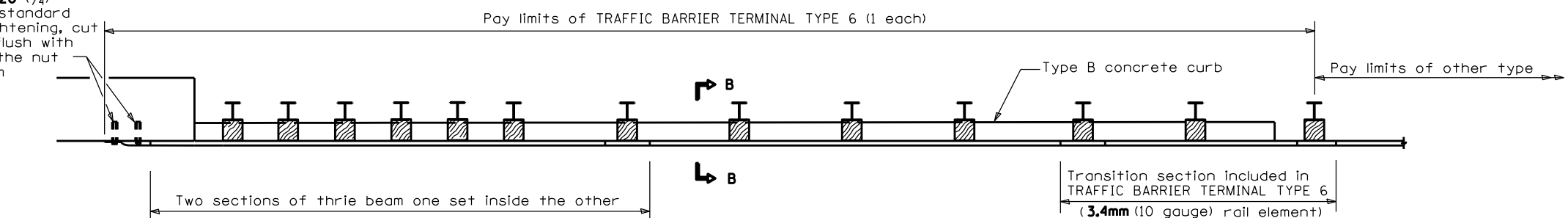
FILE NAME =	USER NAME = *USER*	DESIGNED -	REVISED -	STATE OF ILLINOIS DEPARTMENT OF TRANSPORTATION	PRE-MGS EFFECTIVE 4-1-06 TRAFFIC BARRIER TERMINAL TYPE 5 & 5A STANDARD 631026-02	F.A. RTE.	SECTION	COUNTY	TOTAL SHEETS	SHEET NO.	
*FILEL*		DRAWN -	REVISED -			Y&R.		Y&R.	43	32	
		CHECKED -	REVISED -			CONTRACT NO. 66015					
		DATE -	REVISED -			FED. ROAD DIST. NO. ILLINOIS FED. AID PROJECT					



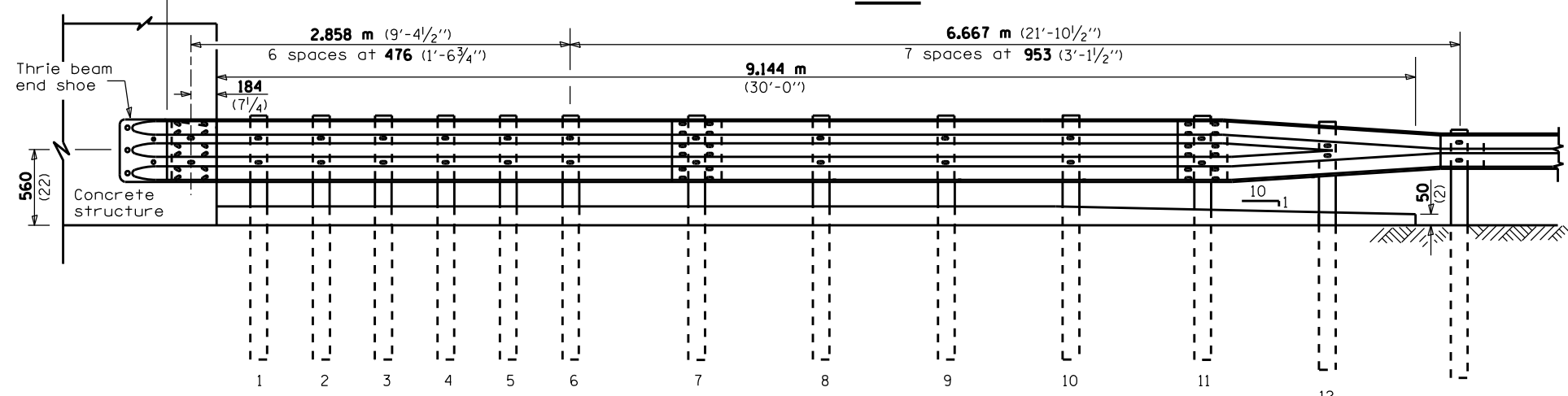


**OTHER CONCRETE STRUCTURE**

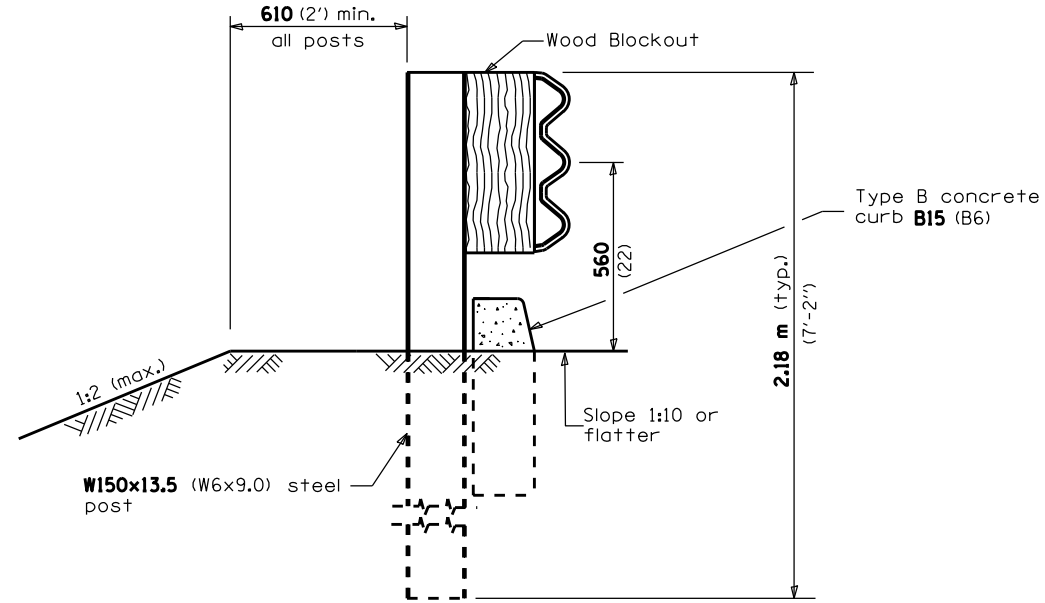
5 Epoxy grouted **M20** ( $\frac{3}{4}$ ) anchor bolts with standard washers. After tightening, cut the anchor bolts flush with nuts, and damage the nut to prevent it from loosening.



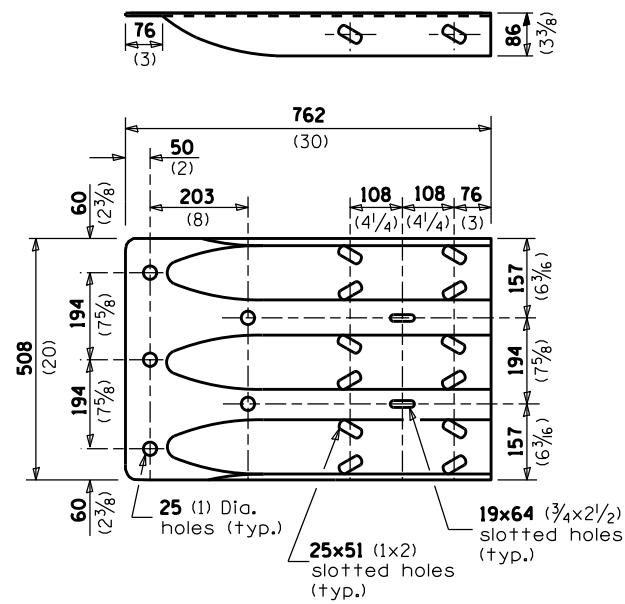
**PLAN**



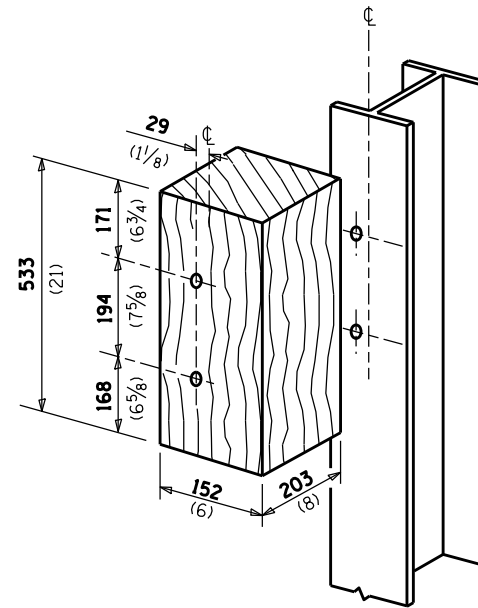
**ELEVATION**



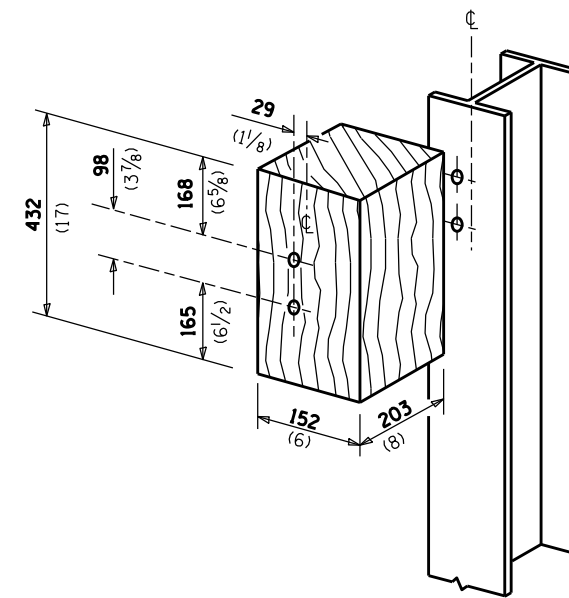
**SECTION B-B**



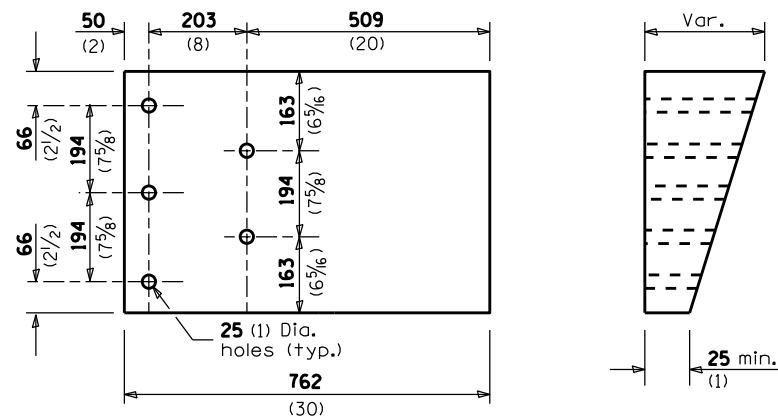
**THRIE BEAM END SHOE DETAIL**



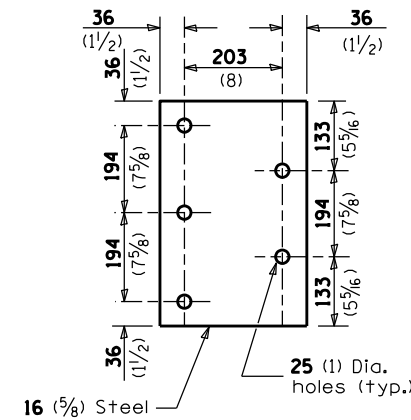
**POSTS 1-11 WOOD BLOCKOUT DETAIL**



**POST 12 WOOD BLOCKOUT DETAIL**

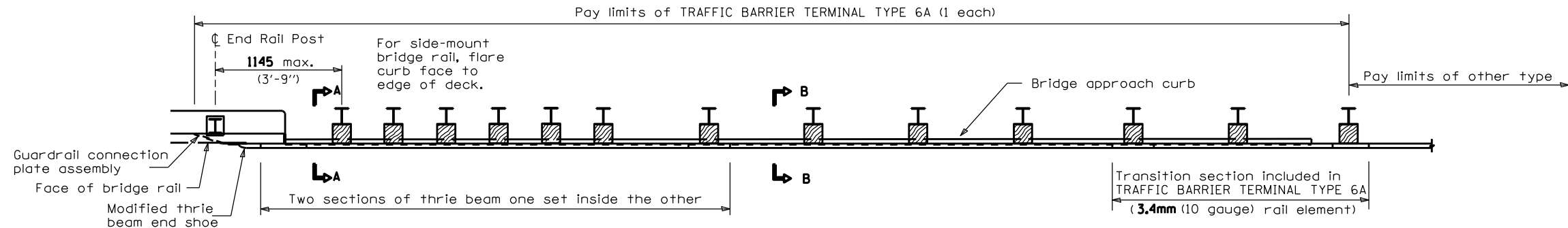


**PARAPET WOOD BLOCK-OUT DETAIL**

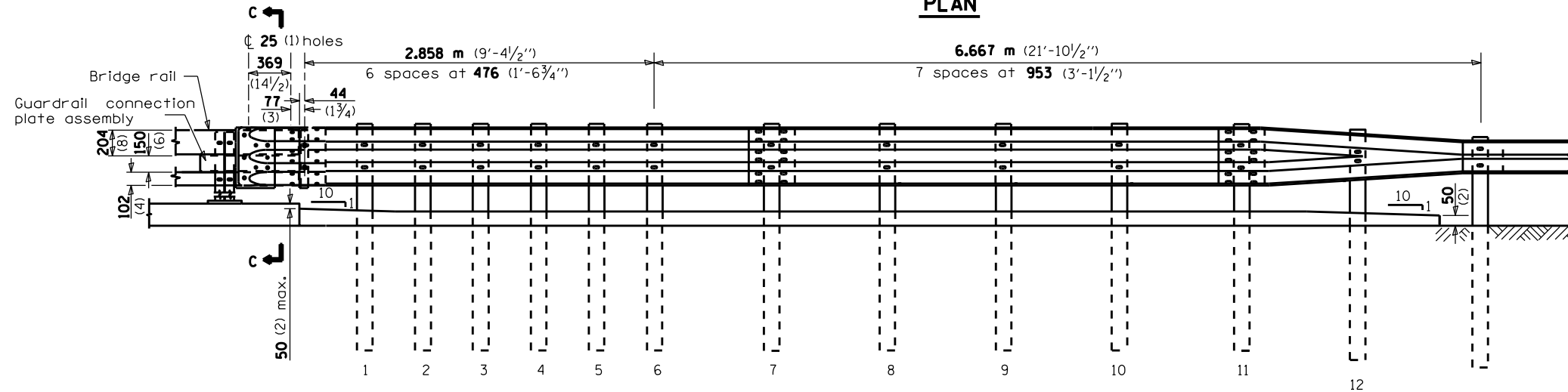


**PARAPET STEEL BEARING PLATE DETAIL**

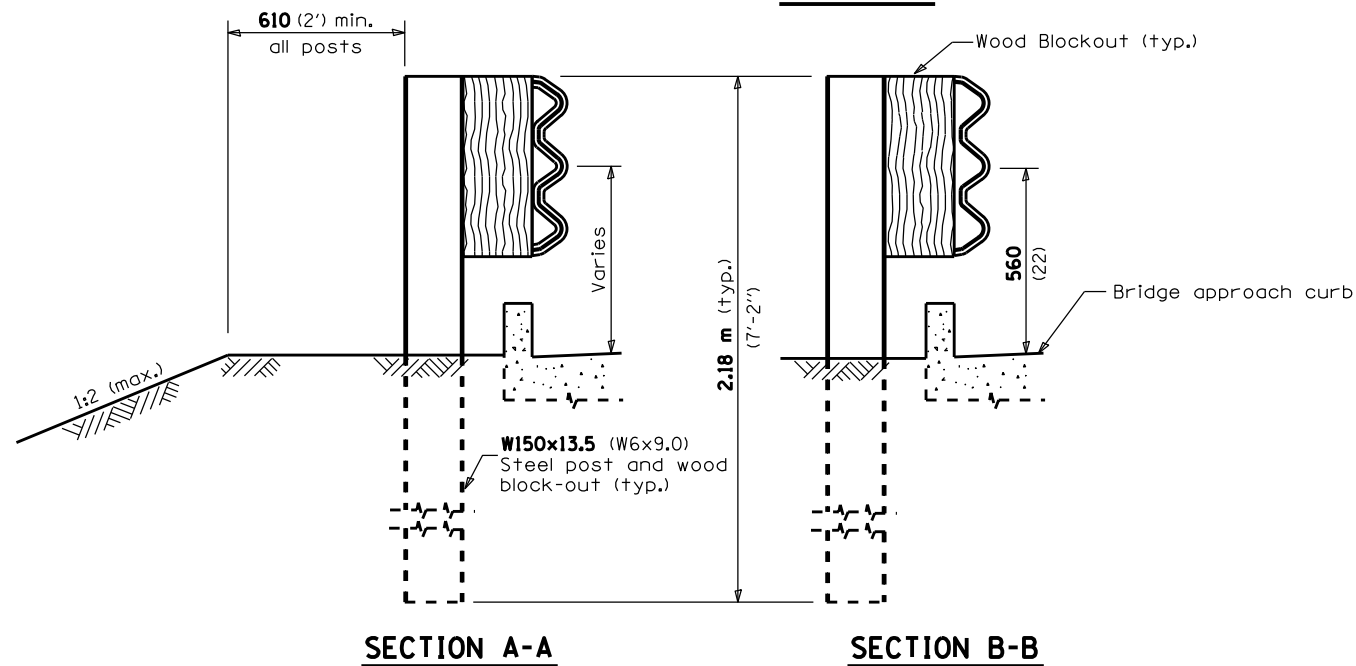
(5 each individual 125x125x16 (5x5x5/8) steel plates with centered 25 (1) holes may be substituted for the plate shown.)



PLAN



ELEVATION



GENERAL NOTES

This standard shows attachment to curb mounted bridge rail. Attachment to side mounted bridge rail is similar.

See Standard 630001 for details of guardrail not shown.

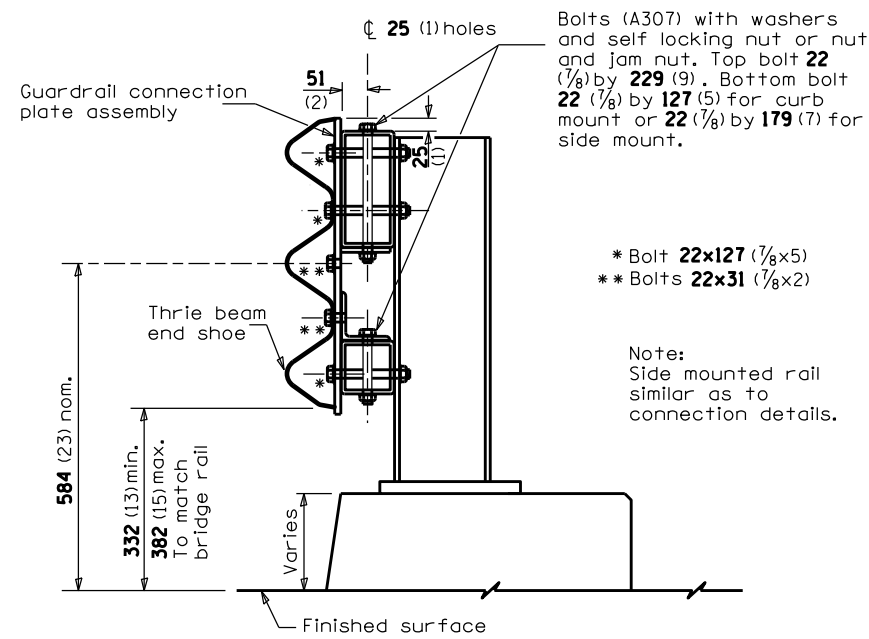
Thrie beam rail shall be bolted to block-out at all posts.

See Standard 420401 for details of bridge approach pavement.

All slope ratios are expressed as units of vertical displacement to units of horizontal displacement (V:H).

All dimensions are in millimeters (inches) unless otherwise shown.

FILE NAME =	USER NAME = \$USER\$	DESIGNED -	REVISED -	STATE OF ILLINOIS DEPARTMENT OF TRANSPORTATION	PRE-MGS EFFECTIVE 4-1-06 TRAFFIC BARRIER TERMINAL, TYPE 6A STANDARD 631032-02	F.A. RTE.	SECTION	COUNTY	TOTAL SHEETS	SHEET NO.	
\$FILEL\$		DRAWN -	REVISED -			Y&R.		Y&R.	43	36	
		CHECKED -	REVISED -			Sheet 1 of 3					
		DATE -	REVISED -			SCALE: _____	SHEET NO. _____ OF _____ SHEETS	STA. _____ TO STA. _____	FED. ROAD DIST. NO. ILLINOIS FED. AID PROJECT		

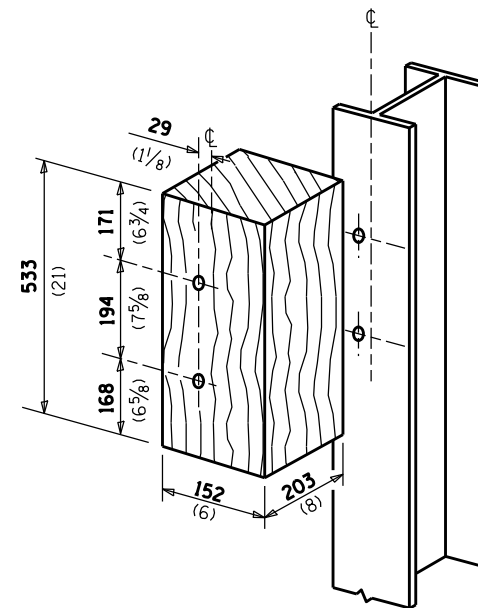


**SECTION C-C**

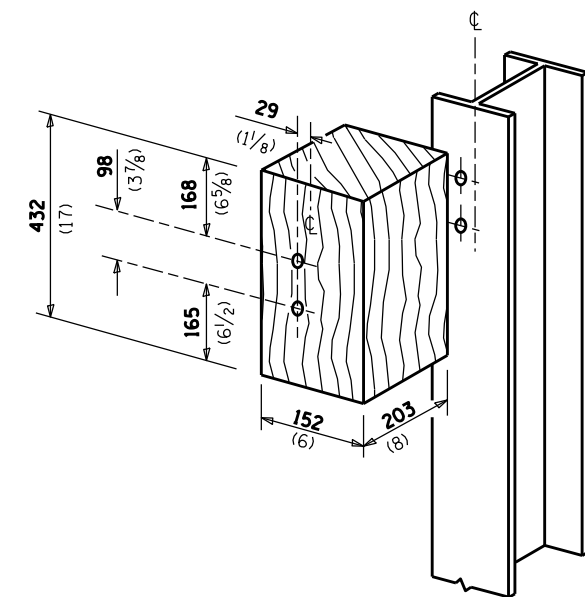
Bolts (A307) with washers and self locking nut or nut and jam nut. Top bolt **22** ( $\frac{7}{8}$ ) by **229** (9). Bottom bolt **22** ( $\frac{7}{8}$ ) by **127** (5) for curb mount or **22** ( $\frac{7}{8}$ ) by **179** (7) for side mount.

\* Bolt **22x127** ( $\frac{7}{8}$ x5)  
 \*\* Bolts **22x31** ( $\frac{7}{8}$ x2)

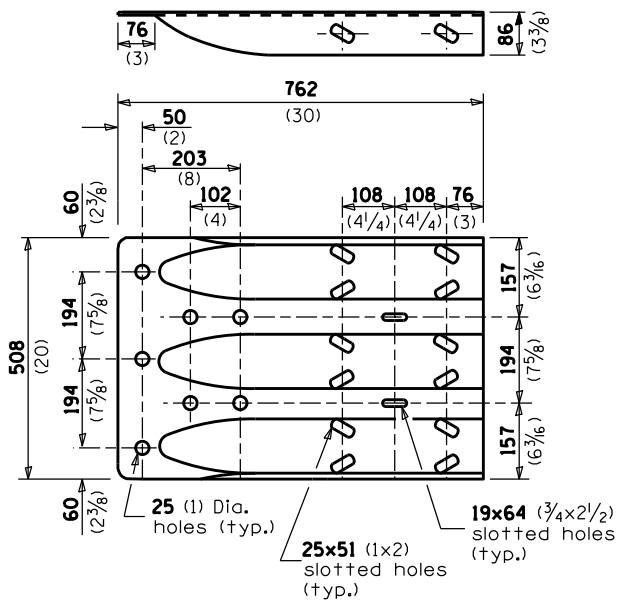
Note:  
 Side mounted rail similar as to connection details.



**POSTS 1-11 WOOD BLOCKOUT DETAIL**

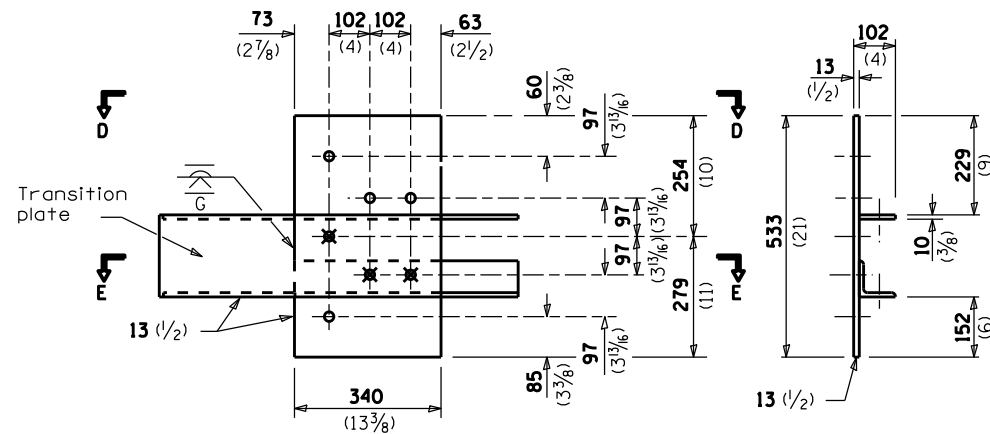


**POST 12 WOOD BLOCKOUT DETAIL**

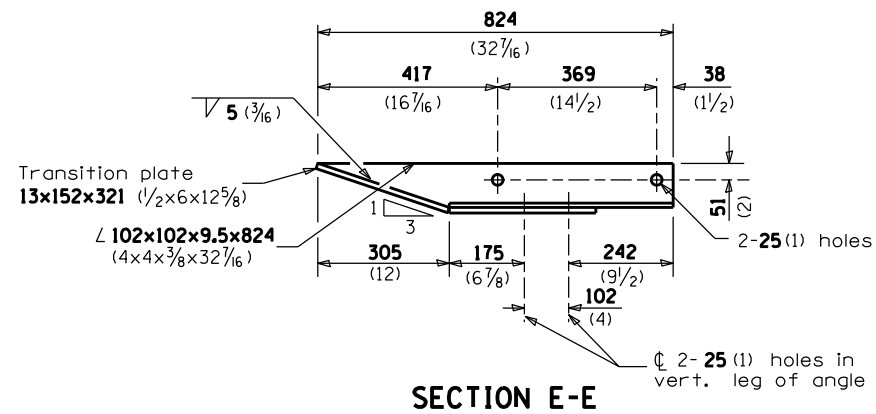
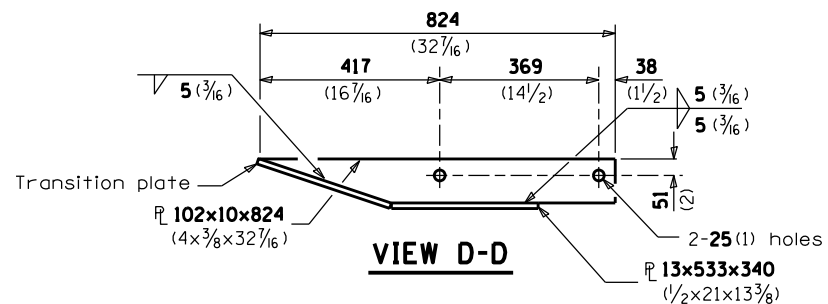


**MODIFIED THRIE BEAM END SHOE DETAIL**

FILE NAME = *FILEL*	USER NAME = *USER*	DESIGNED -	REVISED -	STATE OF ILLINOIS DEPARTMENT OF TRANSPORTATION	PRE-MGS EFFECTIVE 4-1-06 TRAFFIC BARRIER TERMINAL, TYPE 6A STANDARD 631032-02 Sheet 2 of 3	F.A. RTE.	SECTION	COUNTY	TOTAL SHEETS	SHEET NO.	
		DRAWN -	REVISED -			VAR.		VAR.	43	37	
		CHECKED -	REVISED -			CONTRACT NO. 66015					
		DATE -	REVISED -			FED. ROAD DIST. NO. ILLINOIS FED. AID PROJECT					

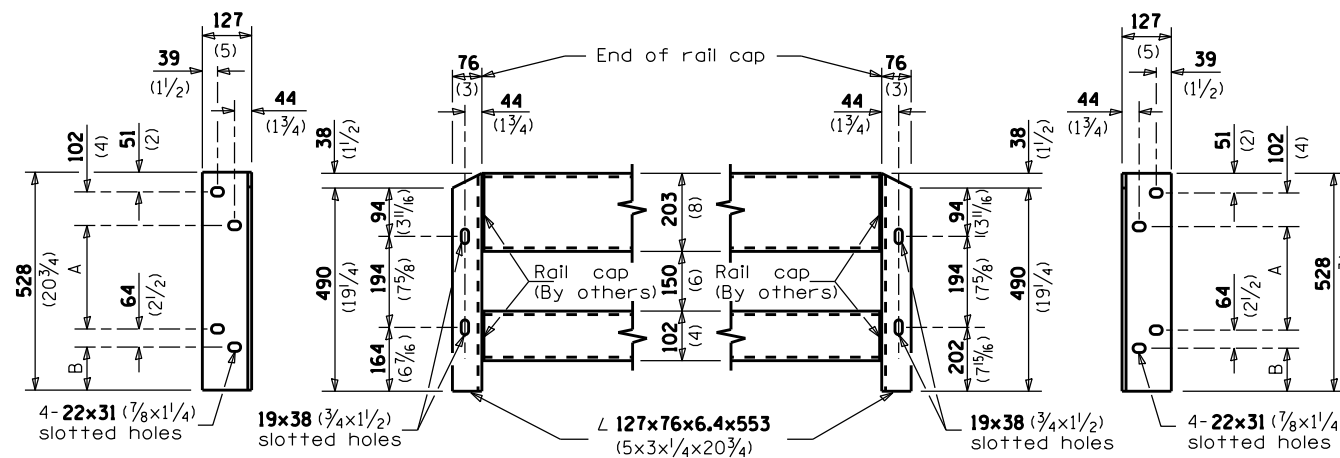


**GUARDRAIL CONNECTION PLATE ASSEMBLY DETAILS**  
(Mirror for opposite end)



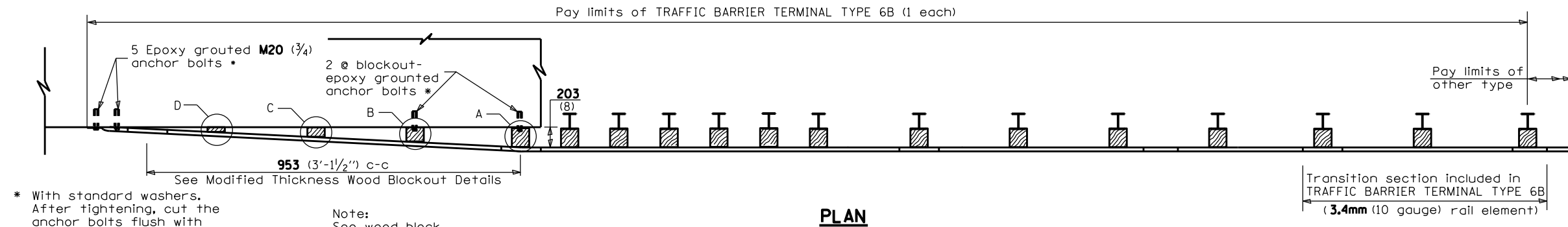
- LEGEND**
- 4-25 (1) holes for 22 (7/8) H.S. bolts and nuts
  - ⊗ Drill and tap 3 holes for 22 (7/8) H.S. bolts.

Dimensions	A	B
For Curb Mounted Rail	222 (8 3/4)	89 (3 1/2)
For Side Mounted Rail	247 (9 3/4)	64 (2 1/2)



**CONNECTION ANGLES**

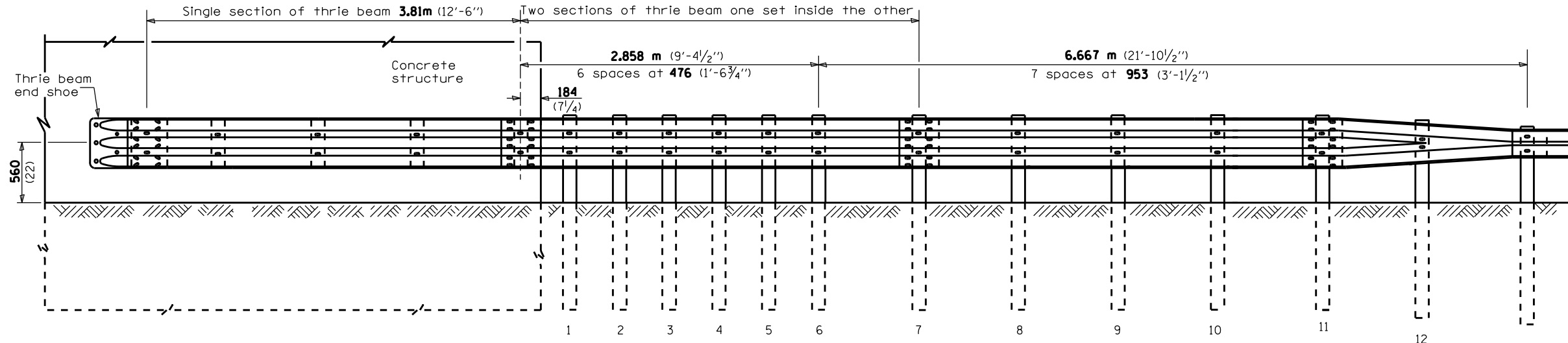
(Install angles to rail caps using 19 (5/8) washers and self-locking nuts or nuts and jam nuts, to be provided by others)



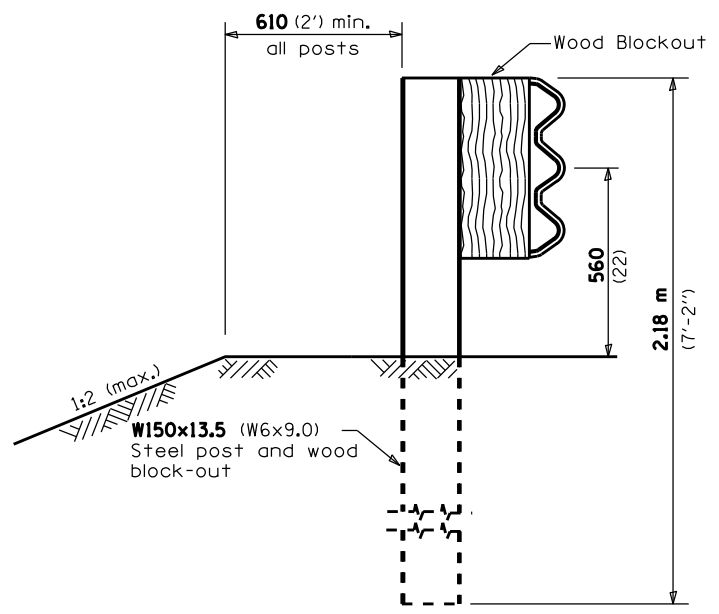
\* With standard washers. After tightening, cut the anchor bolts flush with nuts, and damage the nut to prevent it from loosening.

Note: See wood block details A, B, C. & D

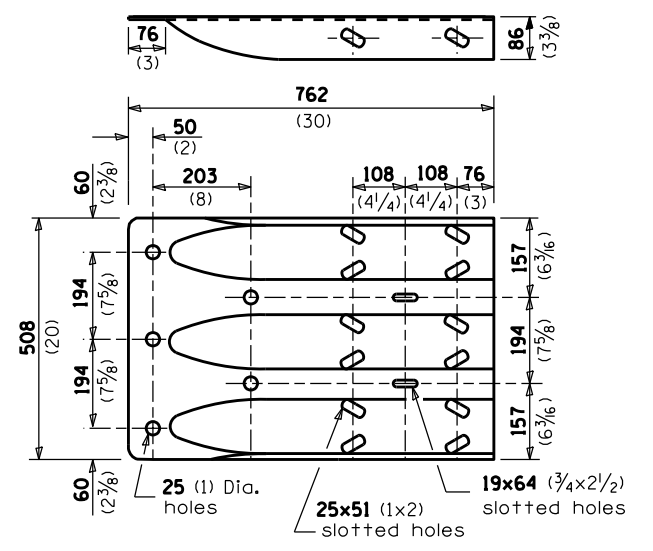
PLAN



ELEVATION



SECTION A-A



THRIE BEAM END SHOE DETAIL

GENERAL NOTES

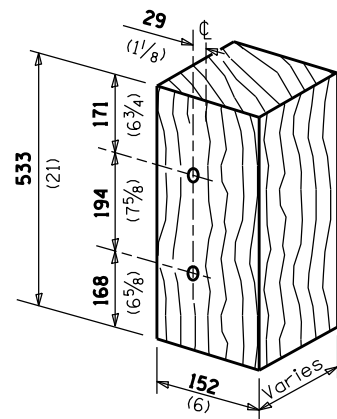
See Standard 630001 for details of guardrail not shown.

Thrie beam rail shall be bolted to block-out at all posts.

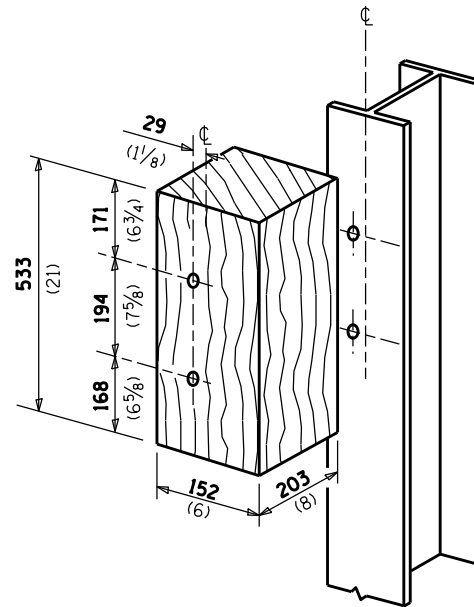
All slope ratios are expressed as units of vertical displacement to units of horizontal displacement (V:H).

All dimensions are in millimeters (inches) unless otherwise shown.

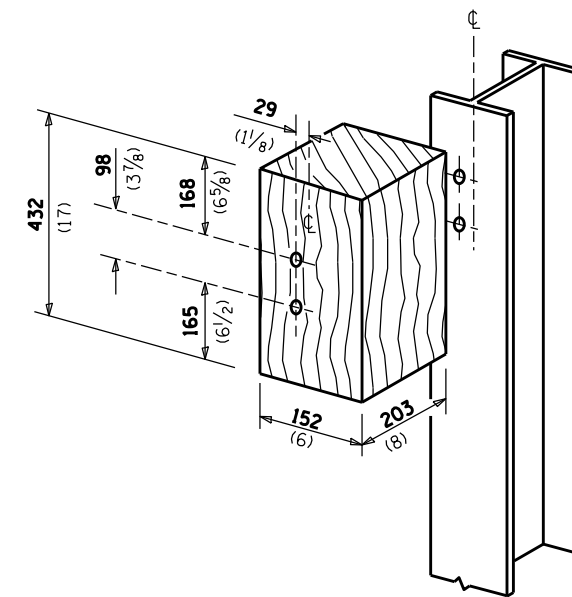
FILE NAME =	USER NAME = \$USER*	DESIGNED -	REVISED -	STATE OF ILLINOIS DEPARTMENT OF TRANSPORTATION	PRE-MGS EFFECTIVE 4-1-06 TRAFFIC BARRIER TERMINAL, TYPE 6B STANDARD 631033-01	F.A. RTE.	SECTION	COUNTY	TOTAL SHEETS	SHEET NO.	
*FILEL\$		DRAWN -	REVISED -			Y&R.	*	Y&R.	43	39	
		CHECKED -	REVISED -			Sheet 1 of 2					
		DATE -	REVISED -			CONTRACT NO. 66015					
				SCALE: _____ SHEET NO. ___ OF ___ SHEETS STA. _____ TO STA. _____		FED. ROAD DIST. NO. ILLINOIS FED. AID PROJECT					



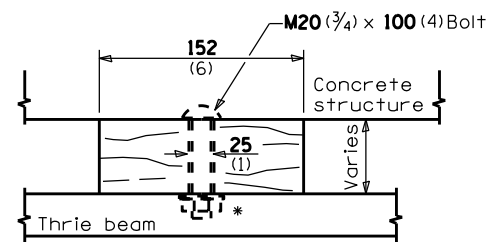
**MODIFIED THICKNESS WOOD BLOCKOUT DETAIL**



**POSTS 1-11 WOOD BLOCKOUT DETAIL**

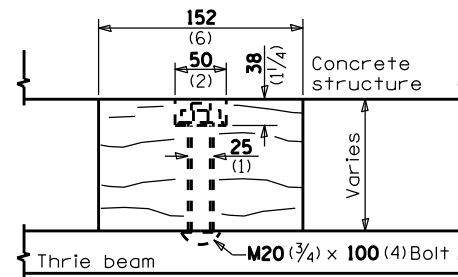


**POST 12 WOOD BLOCKOUT DETAIL**

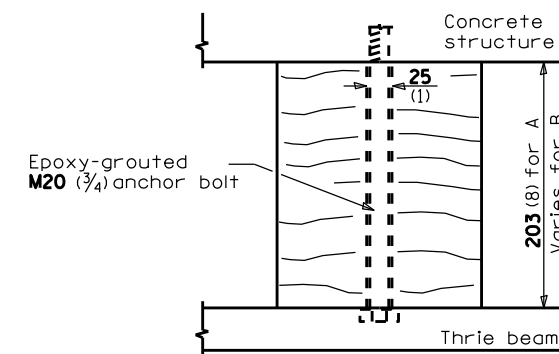


**WOOD BLOCKOUT D**

Bolt to thrie beam with **M20 (3/4)** by **100 (4)** bolt, washer & nut. Reverse direction of insertion. \*

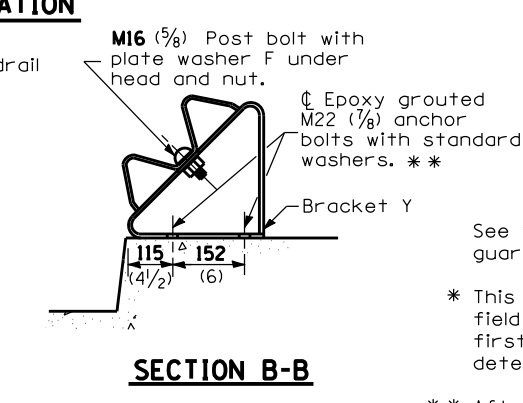
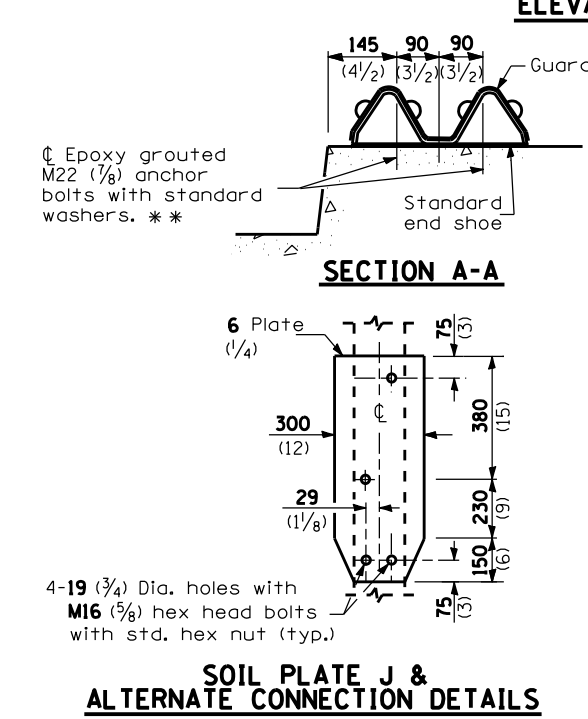
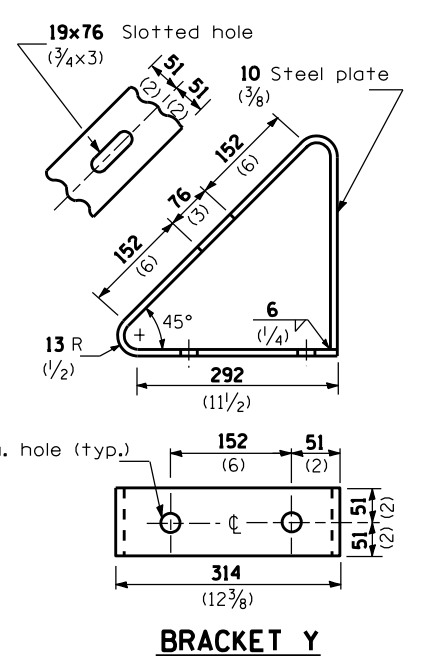
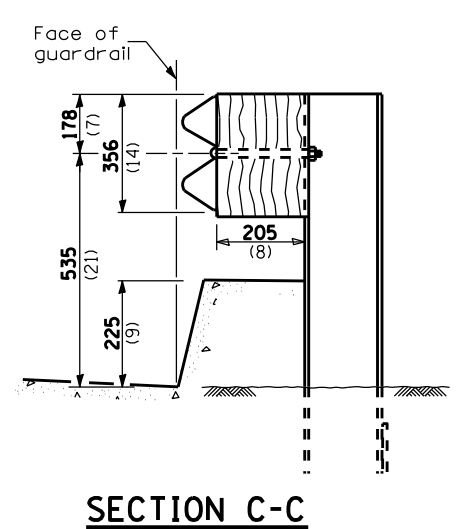
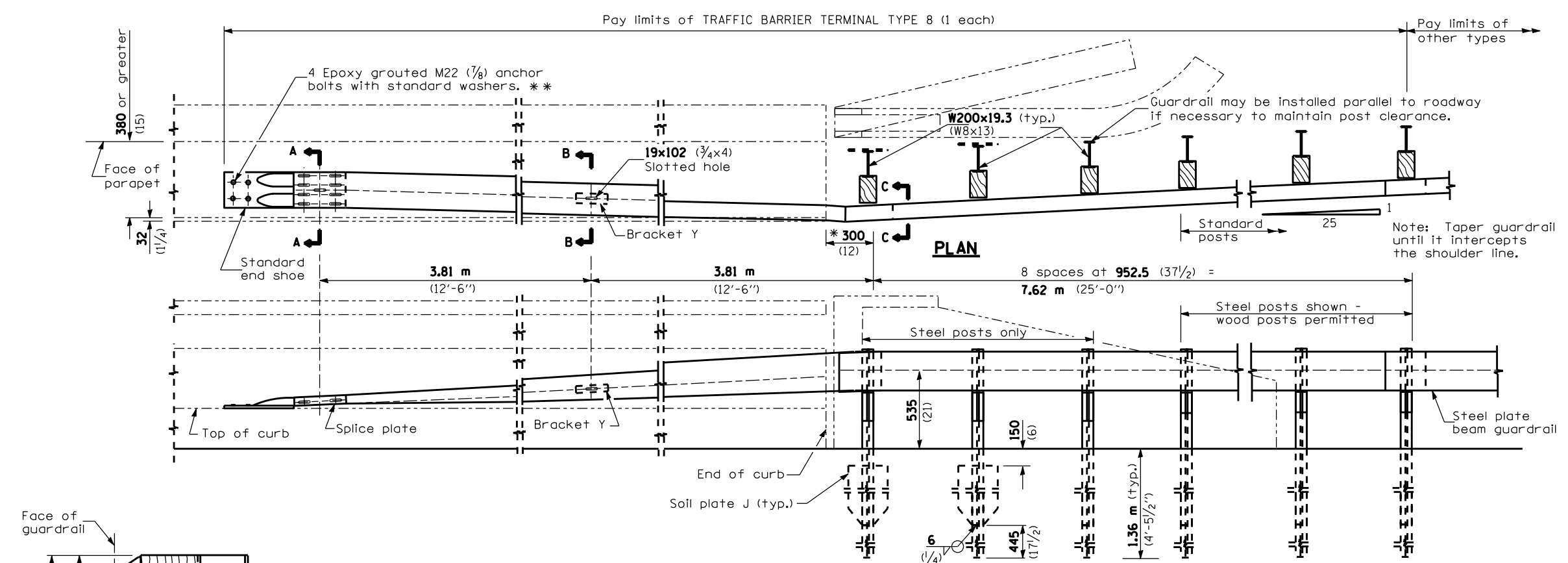


**WOOD BLOCKOUT C**



**WOOD BLOCKOUT A & B**





**GENERAL NOTES**

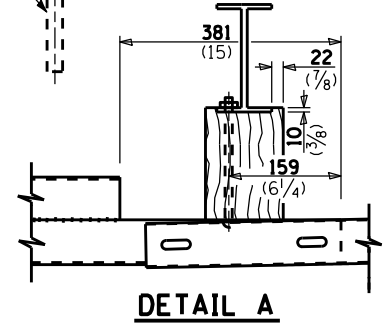
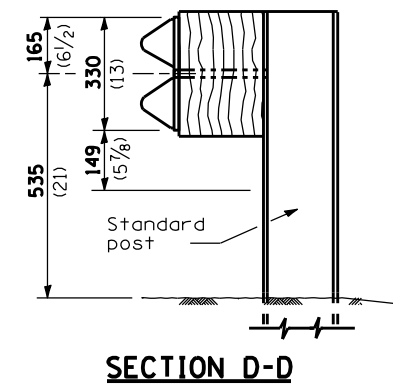
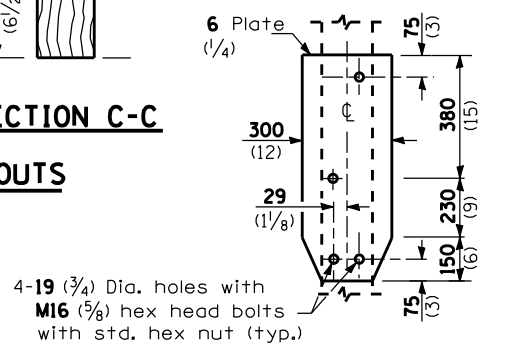
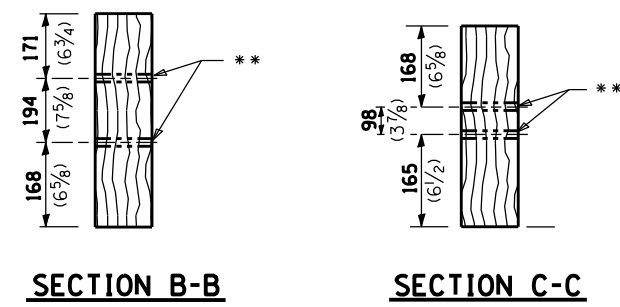
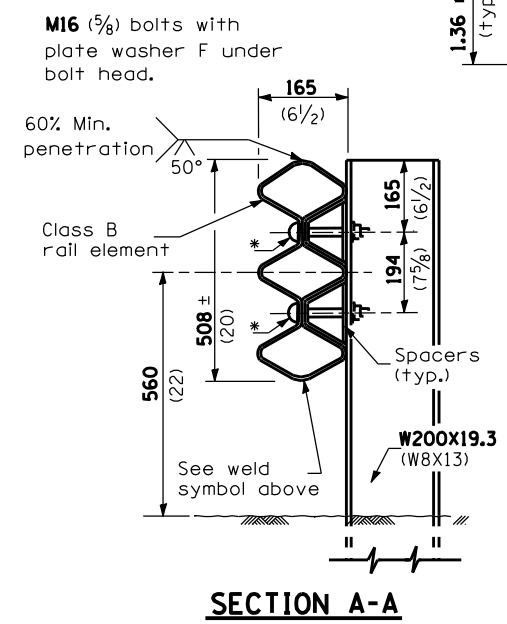
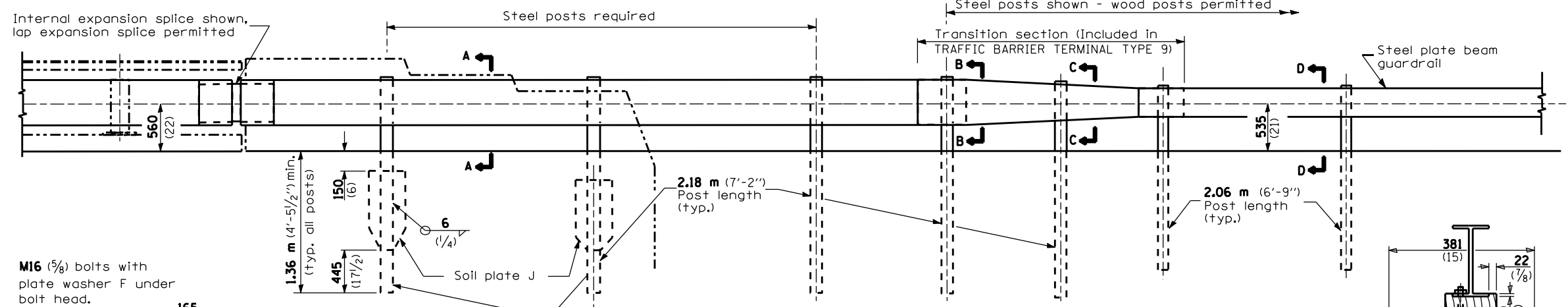
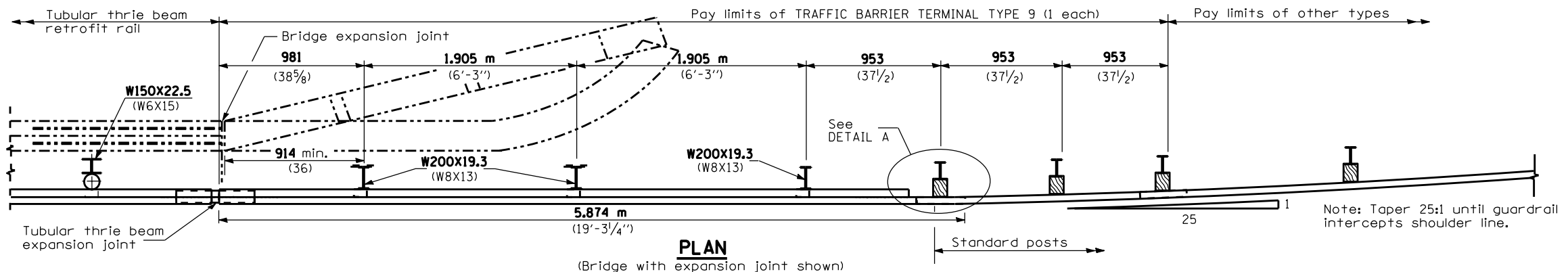
See Standard 630001 for details of guardrail not shown.

\* This dimension may be increased to fit field conditions. This post shall be located first. The layout of the terminal shall be determined by its location.

\*\* After tightening, cut the anchor bolts flush with nuts, and damage the bolt head to prevent them from loosening.

**All dimensions are in millimeters (inches) unless otherwise shown.**

FILE NAME =	USER NAME = *USER*	DESIGNED -	REVISED -	STATE OF ILLINOIS DEPARTMENT OF TRANSPORTATION	PRE-MGS EFFECTIVE 4-1-06 TRAFFIC BARRIER TERMINAL TYPE 8 STANDARD 631036-04	F.A. RTE.	SECTION	COUNTY	TOTAL SHEETS	SHEET NO.
*FILE#		DRAWN -	REVISED -			VAR.		VAR.	43	41
PLOT SCALE = *SCALE*		CHECKED -	REVISED -			CONTRACT NO. 66015				
PLOT DATE = *DATE*		DATE -	REVISED -			FED. ROAD DIST. NO. ILLINOIS FED. AID PROJECT				
				SCALE: _____ SHEET NO. _____ OF _____ SHEETS STA. _____ TO STA. _____						



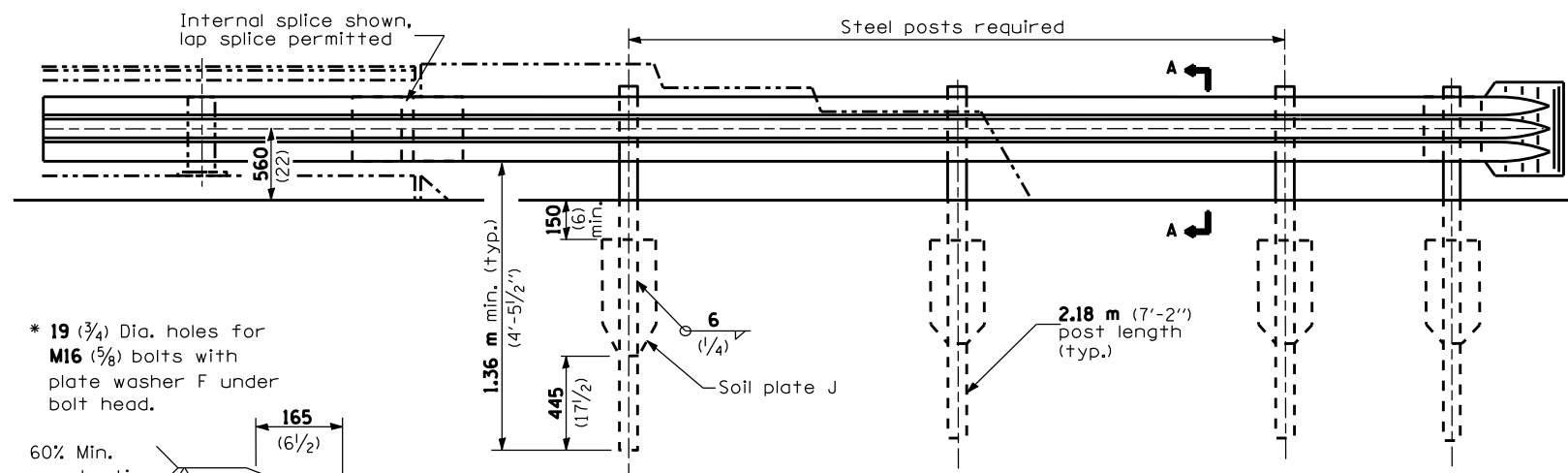
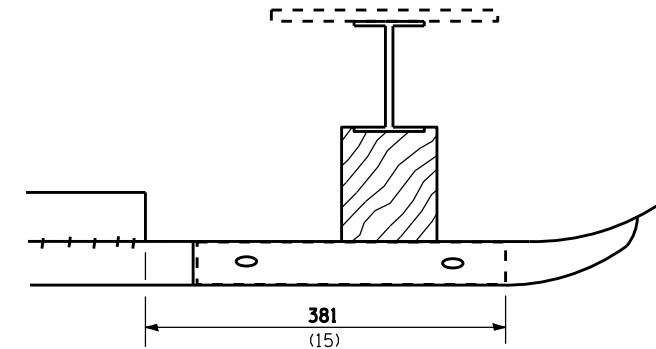
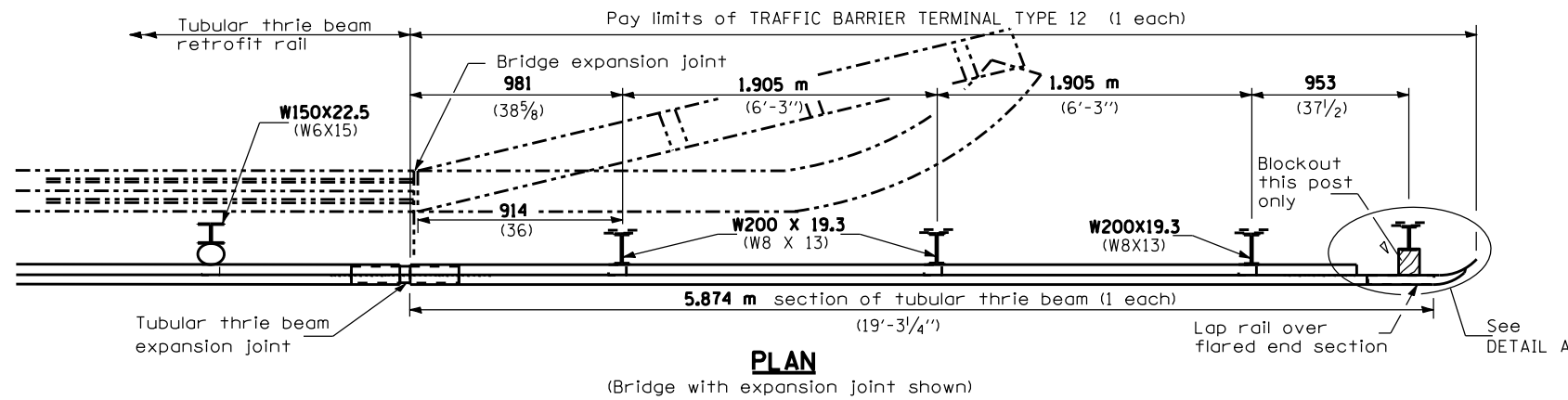
**GENERAL NOTES**

See Standards 509001 and 630001 for details of guardrail elements not shown.

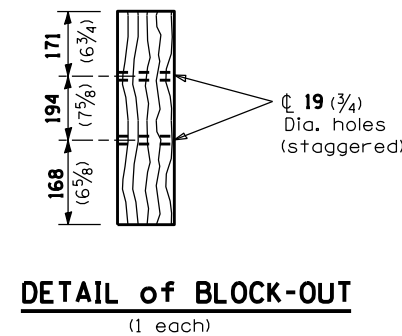
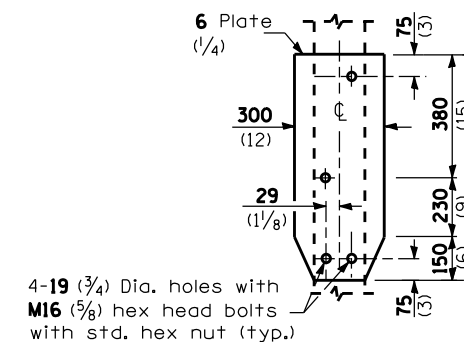
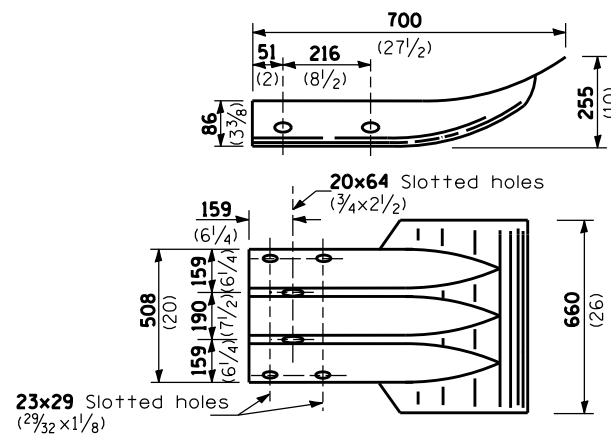
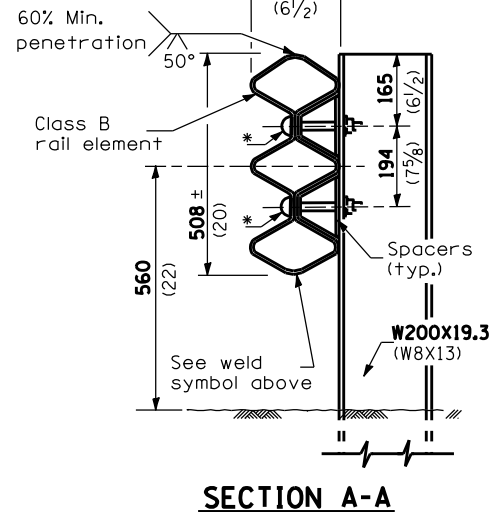
The type 9 terminal shall be installed after the posts for the bridge retrofit rail have been located as shown on Standard 509001.

All dimensions are in millimeters (inches) unless otherwise shown.

FILE NAME =	USER NAME = *USER*	DESIGNED -	REVISED -	STATE OF ILLINOIS DEPARTMENT OF TRANSPORTATION	PRE-MGS EFFECTIVE 4-1-06 TRAFFIC BARRIER TERMINAL TYPE 9 STANDARD 631041-01	F.A. RTE.	SECTION	COUNTY	TOTAL SHEETS	SHEET NO.
*FILEL*		DRAWN -	REVISED -			VAR.		VAR.	43	42
PLOT SCALE = *SCALE*		CHECKED -	REVISED -			CONTRACT NO. 66015				
PLOT DATE = *DATE*		DATE -	REVISED -			FED. ROAD DIST. NO. ILLINOIS FED. AID PROJECT				



\* 19 (3/4) Dia. holes for M16 (5/8) bolts with plate washer F under bolt head.



**GENERAL NOTES**

See Standard 509001 and 630001 for details of guardrail elements not shown.

The type 12 terminal shall be installed after the posts for the bridge retrofit rail have been located as shown on Standard 509001.

All dimensions are in millimeters (inches) unless otherwise shown.

FILE NAME =	USER NAME = \$USER\$	DESIGNED -	REVISED -	STATE OF ILLINOIS DEPARTMENT OF TRANSPORTATION	PRE-MGS EFFECTIVE 4-1-06 TRAFFIC BARRIER TERMINAL TYPE 12 STANDARD 631056-01	F.A. RTE.	SECTION	COUNTY	TOTAL SHEETS	SHEET NO.
*FILEL\$		DRAWN -	REVISED -			VAR.		VAR.	43	43
PLOT SCALE = *SCALE*		CHECKED -	REVISED -			CONTRACT NO. 66015				
PLOT DATE = \$DATE*		DATE -	REVISED -			FED. ROAD DIST. NO. ILLINOIS FED. AID PROJECT				
					SCALE: _____	SHEET NO. ___ OF ___ SHEETS		STA. _____ TO STA. _____		