

# RURAL ENTRANCE SCHEDULE AND MAILBOX TURNOUT DETAILS

**NOTES**

THE HOT-MIX ASPHALT FOR ENTRANCES AND PUBLIC ROADS AND APPROACHES SHALL BE PAID FOR AS INCIDENTAL HOT-MIX ASPHALT SURFACING.

THE COST OF EXCAVATION IS INCLUDED IN THE PAY ITEM INCIDENTAL HOT-MIX ASPHALT SURFACING.

IF THERE IS NOT EXISTING HOT-MIX ASPHALT SHOULDER THEN THE ENTRANCE TAPER STARTS AT THE EDGE OF EXISTING PAVEMENT.

THE COST OF THE BITUMINOUS MATERIALS (PRIME COAT) FOR ENTRANCES AND PUBLIC ROAD APPROACHES SHALL BE INCLUDED IN THE PAY ITEM INCIDENTAL HOT-MIX ASPHALT SURFACING.

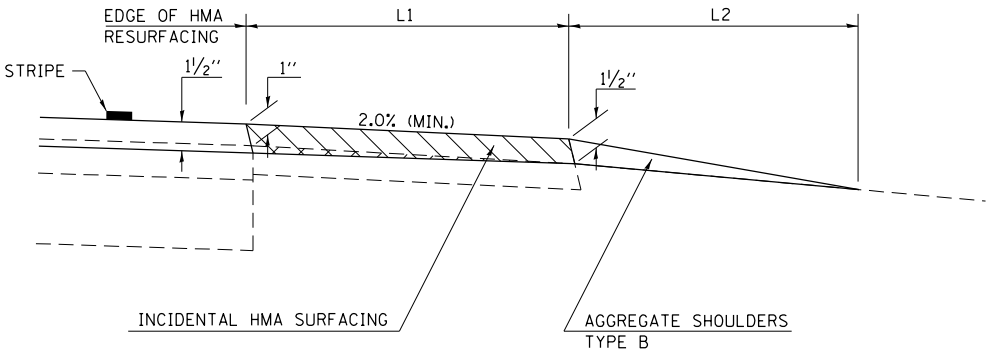

NOTES: THE INCIDENTAL BITUMINOUS SURFACING IS INTENDED TO RESURFACE THE EXISTING ENTRANCES IN THEIR ENTIRETY.

"X" = PROPOSED RESURFACING THICKNESS

**ENTRANCE SCHEDULE**

SIDE	STATION	TYPE	W1	W2	W3	L1	L2	INCIDENTAL HOT-MIX ASPHALT SURFACING	AGGREGATE SURFACE COURSE, TYPE B
								FEET	FEET
RT	234+19.4	PE	60	28	20	6	4	2.5	1
LT	237+34.6	FE	55	33	20	4	6	1.6	2
RT	237+48	PE	40	28	20	4	6	1.3	1
RT	244+07	PE	77	33	28	6	4	3.1	1
RT	248+91.8	CE	54	47	40	6	4	2.8	2
LT	274+72	PRA	72	20	0	35	0	15.0	
RT	285+92	PE	55	24	0	10	0	3.7	
RT	286+10	MBT	46	46	46	6	4	2.6	2
LT	286+89	PRE	55	45	0	10	0	4.7	
<b>TOTALS</b>								<b>37</b>	<b>8</b>

NOTE: SEE DETAILS FOR W1, W2, W3, L1 AND L2 LOCATIONS

