

GENERAL NOTES

Box Culvert End Sections shall be constructed according to the requirements of Section 540 of the Standard Specifications except as modified herein. End sections will be paid for at the contract unit price per each for Box Culvert End Sections of the culvert number specified.

Typical box section dimensions, materials, and reinforcement details for Box Culvert End Sections shall be according to the requirements of AASHTO M 259 or M 273 as required for the design of the portion of the culvert within the limits of Precast Concrete Box Culverts except as modified herein.

Number of sections shown in Side Elevation is for example only. Length and number of precast box sections required to construct Box Culvert End Sections shall be determined by the Contractor.

See roadway plans for embankment slope (V:H).

1" ϕ anchor rods for the culvert ties shall conform to the requirements of ASTM F1554, Grade 105. Structural steel for tie plate and restraint angle shall conform to the requirements of Article 1006.04 of the Standard Specifications. All components of the culvert tie detail shall be galvanized according to the requirements of AASHTO M 111 or M 232 as applicable. 2 1/4" x 2 1/4" x 5/16" plate washers shall be provided under each nut required for the anchor rods. All anchor rods in a culvert tie assembly shall be snug tightened by a few impacts of an impact wrench or the full force of a worker using an ordinary spud wrench. Holes in the walls for the culvert tie assembly may be drilled using core bits in lieu of using formed holes.

Alternate culvert ties similar in strength and stiffness to the plan details may be provided by the Contractor. Alternate culvert ties shall be subject to approval of the Engineer.

The headwall may be cast monolithically with the box section or a superimposed headwall may be cast directly onto the box sections. Anchor rods shall conform to the requirements of Article 1006.09 of the Standard Specifications and the anchor rods and associated hardware for securing the superimposed headwall to the box section shall be galvanized according to the requirements of AASHTO M 111 or M 232 as applicable. Class SI concrete may be used for construction of superimposed headwall.

In lieu of using ferrule loop inserts, the Contractor may attach the superimposed headwall to the box section by epoxy grouting reinforcement bars according to the requirements of Section 584 of the Standard Specifications. The chemical adhesive system shall be capable of achieving the minimum proof load stated with drilled hole depths that do not exceed 2/3 of the thickness of the slab of the box section.

All costs associated with furnishing and installing or constructing the geotextile fabric, toewall, headwall, and culvert ties will not be measured for payment but shall be included in the contract unit price for Box Culvert End Sections of the culvert number specified.

Reinforcement bars designated (E) shall be epoxy coated. Reinforcement bars shall conform to the requirements of ASTM A 706 Gr. 60.

Drain holes shall conform to the requirements of Article 503.11 of the Standard Specifications unless noted otherwise.

Nonwoven geotextile fabric shall conform to the requirements of Article 1080.01. The minimum weight of the fabric shall be 6 oz. / sq. yd..

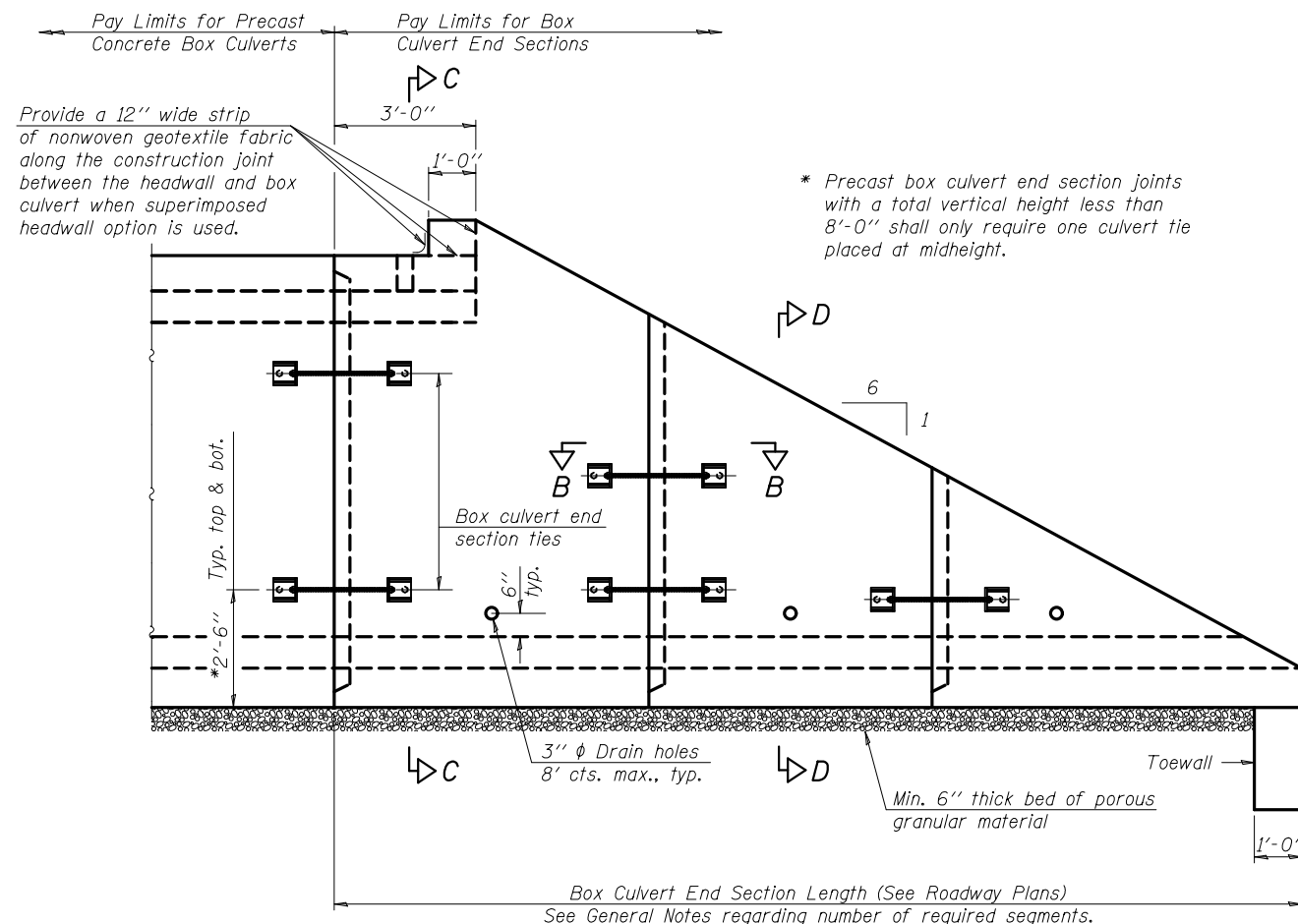

SIDE ELEVATION

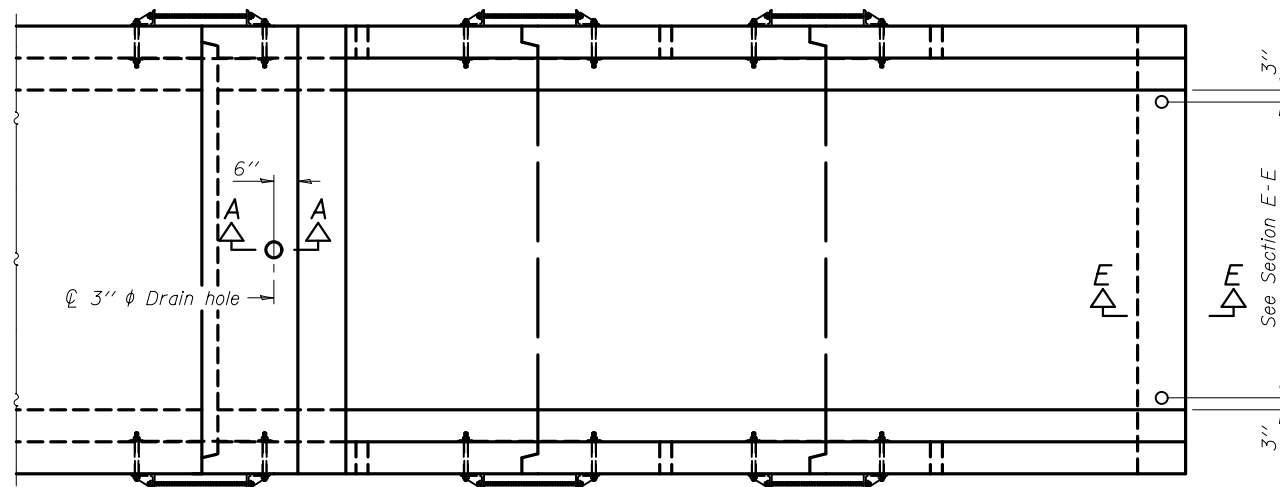

PLAN VIEW

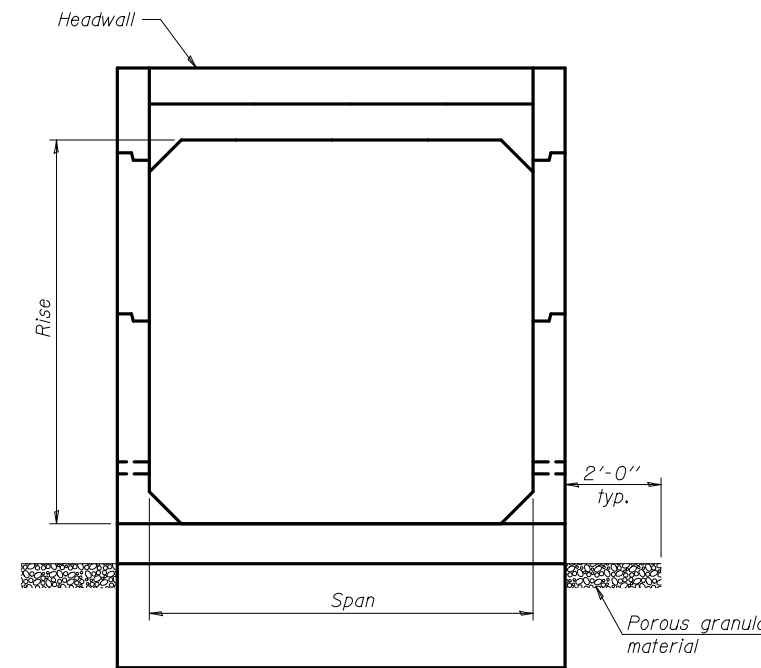

END VIEW

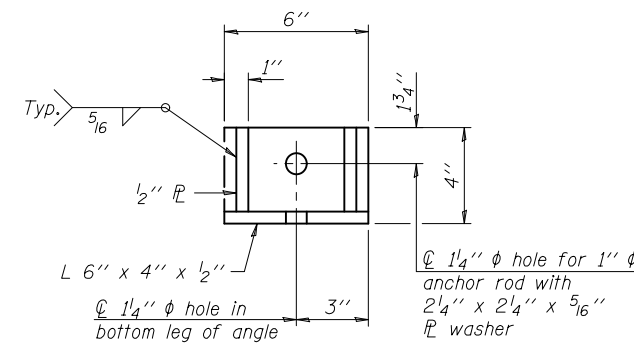

RESTRAINT ANGLE DETAIL

12" x 12" block of CA5, CA7 or CA11 coarse aggregate placed over drain opening. Block of aggregate shall be completely wrapped in nonwoven geotextile fabric.

Provide a double layer of 12" x 12" nonwoven geotextile fabric centered over the drain hole. Fabric shall be sealed to the concrete with mastic.

3" ϕ PVC drain cast with the concrete (Adjust location to clear reinforcement).

1/2" Square foam blockout around PVC drain (to be removed after concrete has cured)

SECTION A-A

(All costs associated with furnishing and constructing the above drain details will not be measured for payment but shall be included in the contract unit price for the end section.)

(Sheet 1 of 2)

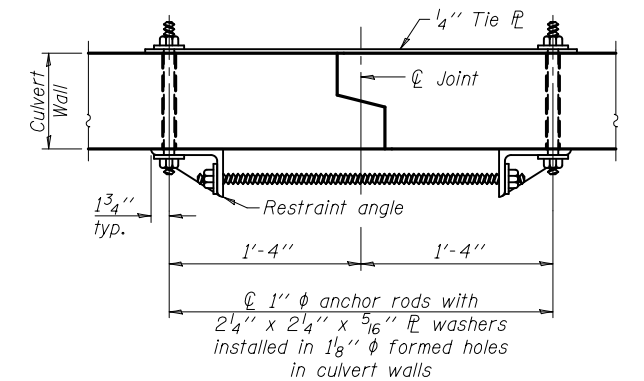

SECTION B-B
(Showing culvert tie details)

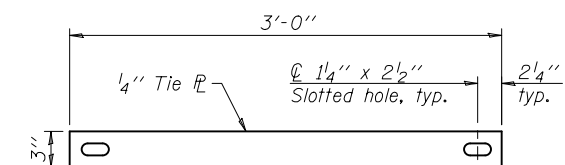

TIE PLATE DETAIL

DESIGNED -	EXAMINED	DATE -
CHECKED -	ENGINEER OF BRIDGE DESIGN	
DRAWN -	PASSED	
CHECKED -	ENGINEER OF BRIDGES AND STRUCTURES	

**STATE OF ILLINOIS
DEPARTMENT OF TRANSPORTATION**

BOX CULVERT END SECTION DETAILS

SHEET NO. 1 OF 2 SHEETS

F.A.P. RTE.	SECTION	COUNTY	TOTAL SHEETS	SHEET NO.
327	(16,17,18)RS-3	MARION	83	75
CONTRACT NO. 76F28				
ILLINOIS FED. AID PROJECT				