

SN 060-2491

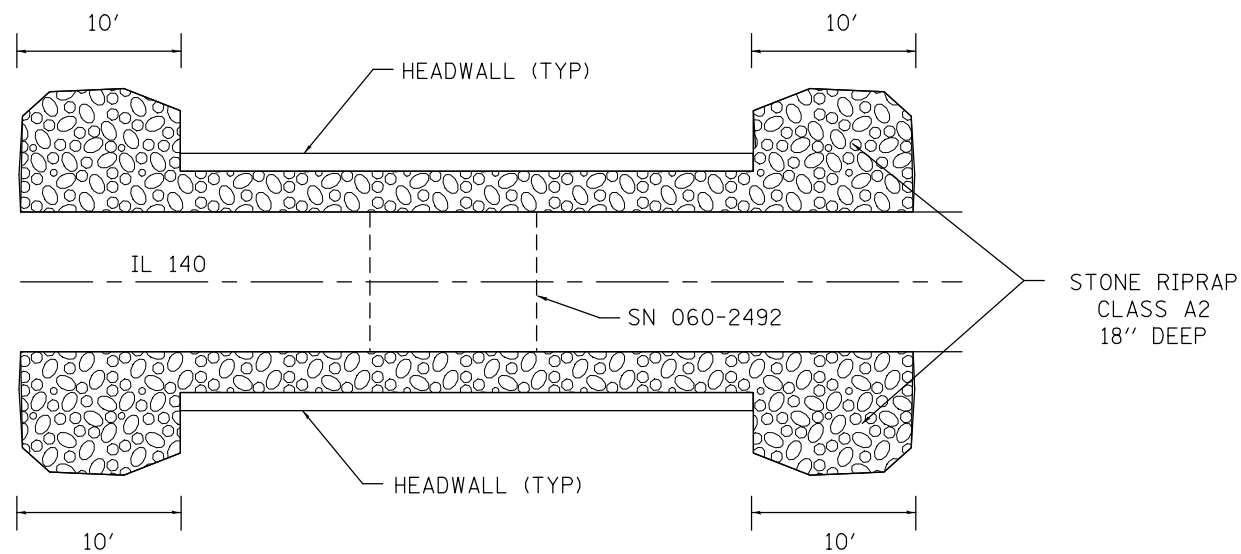

SN 060-2492

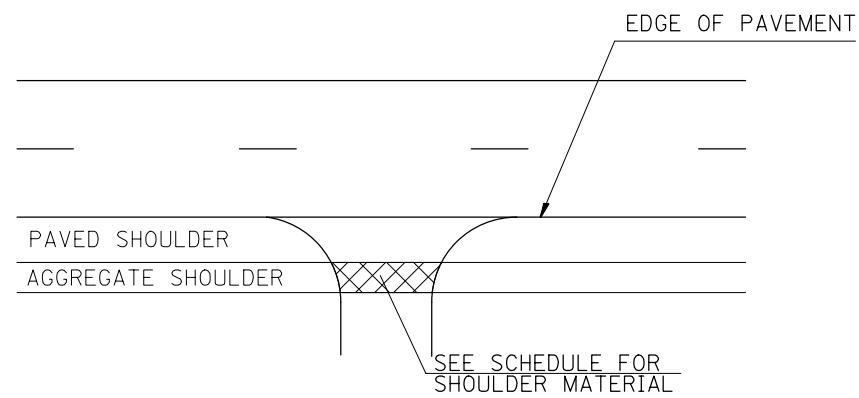

SIDEROAD DETAIL

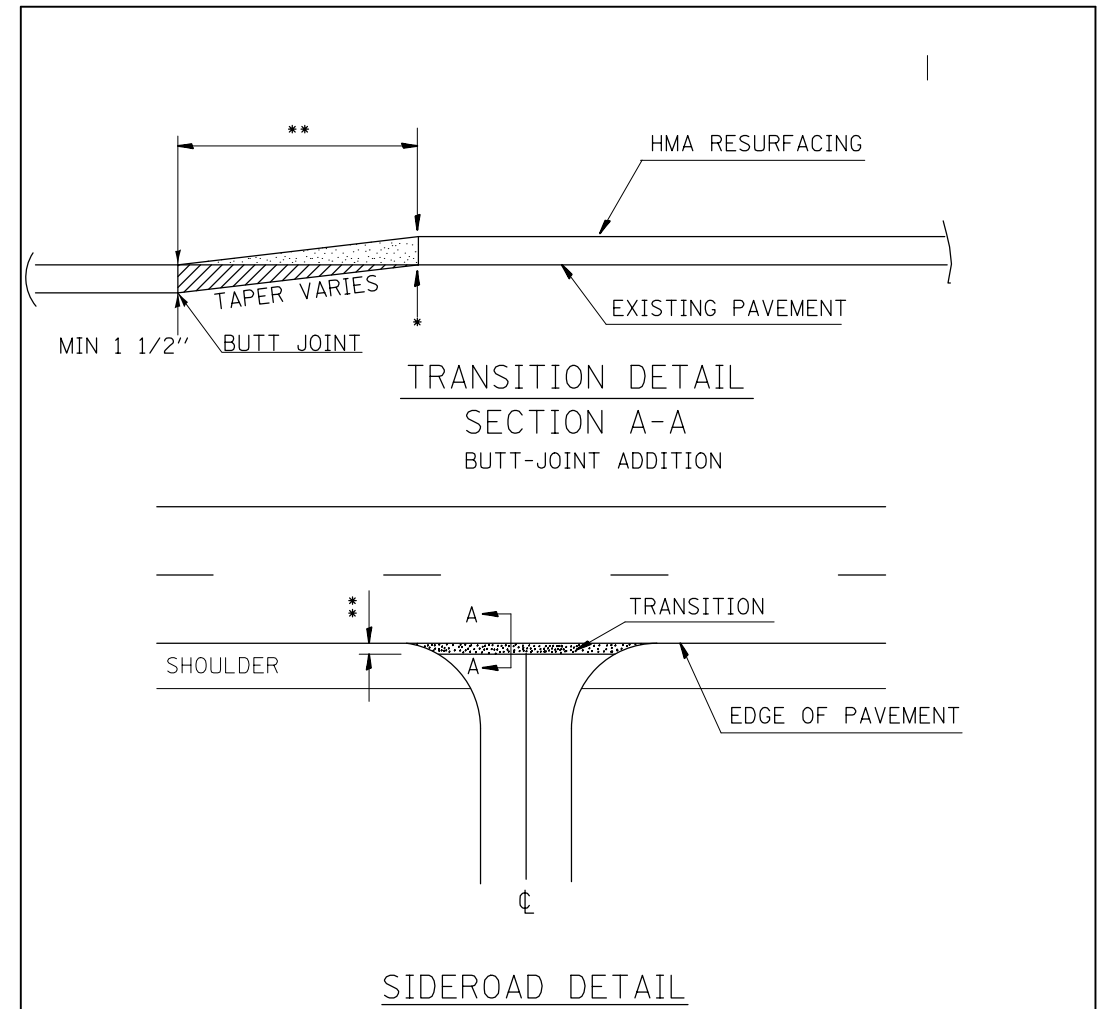

| *EOP ELEVATION CHANGE | **TOTAL TRANSITION LENGTH |
|-----------------------|---------------------------|
| 3/4"                  | 3.5'                      |
| 1"                    | 5'                        |
| 1-1/2"                | 7.5'                      |
| 2"                    | 10'                       |
| 2-1/2"                | 12.5'                     |
| 3"                    | 15'                       |
| 3-1/2"                | 17.5'                     |
| 4"                    | 20'                       |
| 4-1/2"                | 22.5'                     |
| 5"                    | 25'                       |
| 5-1/2"                | 27.5'                     |
| 6"                    | 30'                       |

NOTE:  
WHERE THE HMA TRANSITION IS MATCHING INTO AN EXISTING HMA SIDE ROAD SURFACE, A MILLED BUTT JOINT SHALL BE CONSTRUCTED WITHIN THE LIMITS OF THE TOTAL TRANSITION LENGTH ON THE LOCAL ROUTE.

|  |                               |            |           |
|--|-------------------------------|------------|-----------|
| FILE NAME =  | USER NAME = burnsideem        | DESIGNED - | REVISED - |
| et:\pw\work\p\dot\burnsideem\d0351326\d076g58-sht-plan.dgn |                               | DRAWN -    | REVISED - |
|  | PLOT SCALE = 100.0000' / 1in. | CHECKED -  | REVISED - |
|  | PLOT DATE = 3/20/2014         | DATE -     | REVISED - |

STATE OF ILLINOIS  
DEPARTMENT OF TRANSPORTATION

MISC DETAILS

SCALE: SHEET NO. OF SHEETS STA. TO STA.

|   |                   |         |              |           |
|---|-------------------|---------|--------------|-----------|
| F.A.P. RTE.                                   | SECTION           | COUNTY  | TOTAL SHEETS | SHEET NO. |
| 785   | (133,134,135)RS-4 | MADISON | 28           | 19        |
| CONTRACT NO. 76G58                            |                   |         |              |           |
| FED. ROAD DIST. NO. ILLINOIS FED. AID PROJECT |                   |         |              |           |